

F. D. SPEAR.
LANTERN.

APPLICATION FILED JAN. 23, 1909.

959,635.

Patented May 31, 1910.

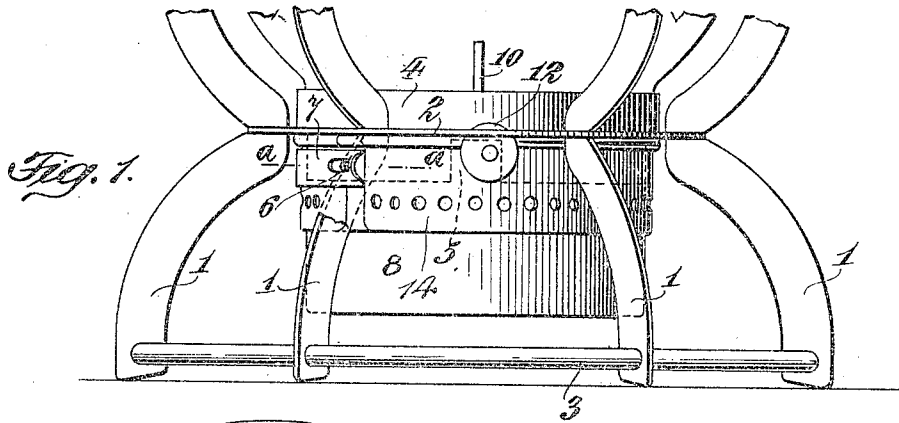

Fig. 1.

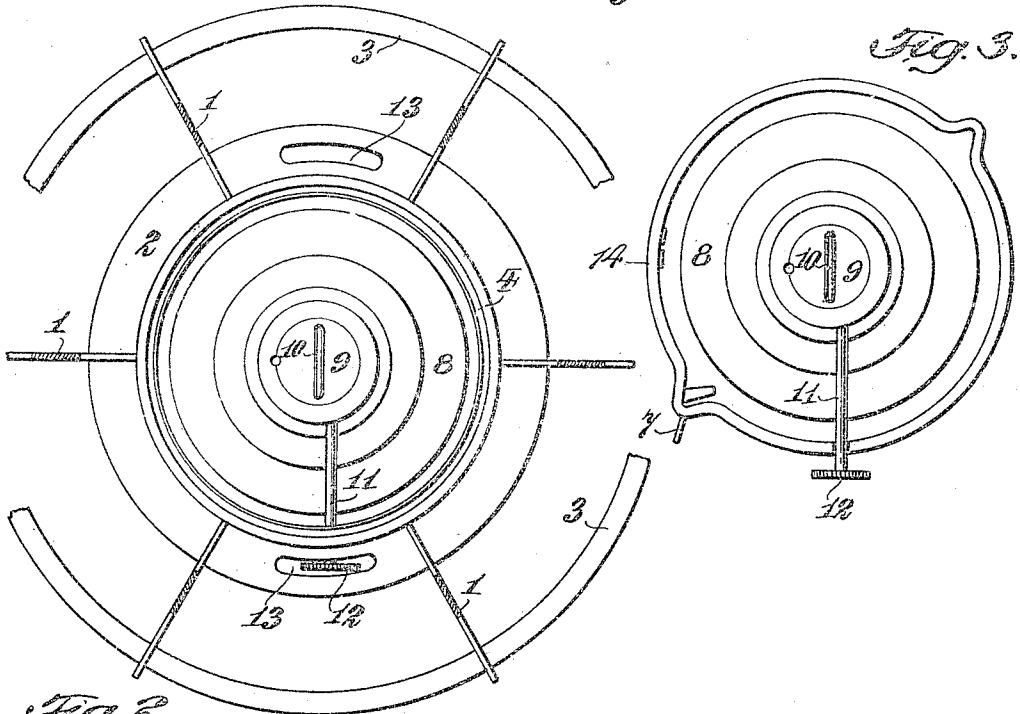

Fig. 3.

Fig. 2.

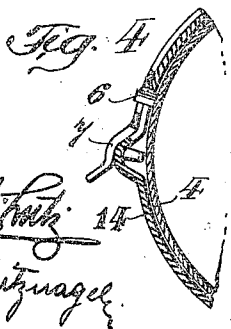

Fig. 4.

WITNESSES
Julius A. Smith
Adalbert Gutzmaier

INVENTOR
 Furman D. Spear.
 BY *A. M. Pierce*,
 ATTORNEY,

UNITED STATES PATENT OFFICE.

FURMAN D. SPEAR, OF BROOKLYN, NEW YORK, ASSIGNOR TO ARMSPEAR MANUFACTURING COMPANY, OF NEW YORK, N. Y.

LANTERN.

959,635.

Specification of Letters Patent. Patented May 31, 1910.

Application filed January 23, 1909. Serial No. 473,821.

To all whom it may concern:

Be it known that I, FURMAN D. SPEAR, a citizen of the United States, residing at Brooklyn, in the county of Kings and State of New York, have invented certain new and useful Improvements in Lanterns, of which the following is a specification, reference being had therein to the accompanying drawing.

My invention relates to the construction and arrangement of hand lanterns, especially those in common use by railroads, and generally known as railroad hand lanterns, and has for its object the provision of a simple outside wick regulating device and at the same time maintaining the common and long established means for detachably connecting the oil font to the body of the lantern, and for locating the burner in the most effective position with relation to the oil font and globe, and providing protection for the exterior part of the device.

To attain the desired end, my invention consists essentially in a lantern provided with a burner the regulating shaft whereof projects outside the body of the lantern, and having a horizontal flat ring connected to upright guards, in combination with an oil font provided with a hoop, the upper edge whereof approximately abuts against the under side of the horizontal ring, and means for detachably securing the oil font in place; and my invention also involves certain other novel and useful combinations or arrangements of parts, and peculiarities of construction and operation, all of which will be hereinafter first fully described, and then pointed out in the claim.

In the drawing, Figure 1 is an elevation of the lower portion of a lantern embodying my invention. Fig. 2 is a plan view thereof. Fig. 3 is a plan view of the oil font and attached hoop removed from the lantern. Fig. 4 is a horizontal sectional view of a fragment of the hoops 4 and 14 illustrating the connection of the two at lines *a— a* of Fig. 1.

Similar numerals of reference, wherever they occur, indicate corresponding parts in all the figures.

1 are the upright guards of a lantern secured to a flat, horizontal ring guard 2, wherein are slots 13.

3 is a horizontal ring guard at the bottom of the uprights 1.

4 is a body hoop secured to the ring 2, and extending downward as indicated by dotted lines in Fig. 1 of the drawing, said hoop being cut away at each side as indicated at 5.

6 is a pin projecting from the hoop 4 and arranged to engage the oil font hoop 14, being detachably held in place by a spring catch 7 secured to the oil font hoop 14.

The oil font 8 has secured thereto a hoop 14. The upper edge of the hoop 14 approximately abuts against the under side of a horizontal ring 2.

9 is the burner having a wick tube 10, ratchet shaft 11, and manipulating button 12.

Heretofore in lanterns of the class to which my invention relates wherein an elongated burner shaft projecting outside the lamp body was employed, it has been necessary to remove the globe and pass the oil pot down into its seat and then replace the globe thereover, an inconvenient and awkward operation. By my construction, this is avoided, while at the same time the well known method of securing the oil font in place is retained, and the relative positions of the burner and globe requisite to the proper combustion of signal oil is secured.

When constructed and arranged in accordance with the foregoing description my improved lantern while extremely simple and compact will be found very effective in operation.

In seating the oil font in place, the hoop 14 is passed up beneath the horizontal ring 2, the ratchet shaft entering the opening 5 in the body hoop, and by a slight turn the catch mechanism is caused to operate and lock the oil font in place. The manipulating button 12 is located outside the lantern body and enters the slot 13 in the ring 2, and while the button is free for turning at will by hand, it is protected against being accidentally struck. If found desirable, the regulating button 12 may be carried outside the ring guard, and the slots 13 dispensed with. By locating the oil font in the position obtained by my construction, the oil has to be drawn upward in burning but a short distance, and at the same time the flame is well elevated within the globe.

Having now fully described my invention, what I claim as new therein and desire to secure by Letters Patent, is:

110

In a lantern provided with a burner, the regulating shaft whereof projects outside the body of the lantern, the combination with a horizontal ring guard connected to upright guards and to a body hoop, of an oil font provided with a hoop, the upper edge whereof approximately abuts against the under side of the horizontal ring guard and on the exterior of the body hoop, and

means for detachably securing the oil font in place.

In testimony whereof I hereto affix my signature in presence of two witnesses.

FURMAN D. SPEAR.

Witnesses:

FRANCIS H. DERREY,
CASPER K. FREEMAN.