

[54] ELECTRO-ACOUSTIC TRANSDUCER

[75] Inventor: Sinichiro Kawamura, Yokohama, Japan

[73] Assignee: Hitachi, Ltd., Tokyo, Japan

[22] Filed: Mar. 6, 1972

[21] Appl. No.: 232,142

[30] Foreign Application Priority Data

Mar. 10, 1971 Japan..... 46-15019

[52] U.S. Cl..... 179/115.5 R; 179/119 R; 335/231

[51] Int. Cl..... H04r 9/02

[58] Field of Search..... 179/115.5 R, 117, 119 R; 335/231

[56] References Cited

UNITED STATES PATENTS

1,953,542 4/1934 Pridham..... 179/115.5 R  
 3,079,472 2/1963 Sariti..... 179/119 R  
 3,413,579 11/1968 Sloan..... 179/119 R

FOREIGN PATENTS OR APPLICATIONS

1,361,069 6/1963 France..... 335/231

Primary Examiner—Kathleen H. Claffy  
 Assistant Examiner—George G. Stellar  
 Attorney, Agent, or Firm—Craig & Antonelli

[57] ABSTRACT

An electro-acoustic transducer in which a voice coil having an axial length larger than the thickness of a yoke is disposed in the magnetic flux gap defined between a pole piece and the yoke, and an audio signal is applied to the voice coil for causing vibrations of the voice coil. In the electro-acoustic transducer, a short-circuit ring is disposed around the pole piece for cancelling the portion of a.c. magnetic flux which emanates from the voice coil and circulates through the magnetic circuit, so as to reduce second harmonic distortions appearing in the acoustic output signal.

9 Claims, 4 Drawing Figures

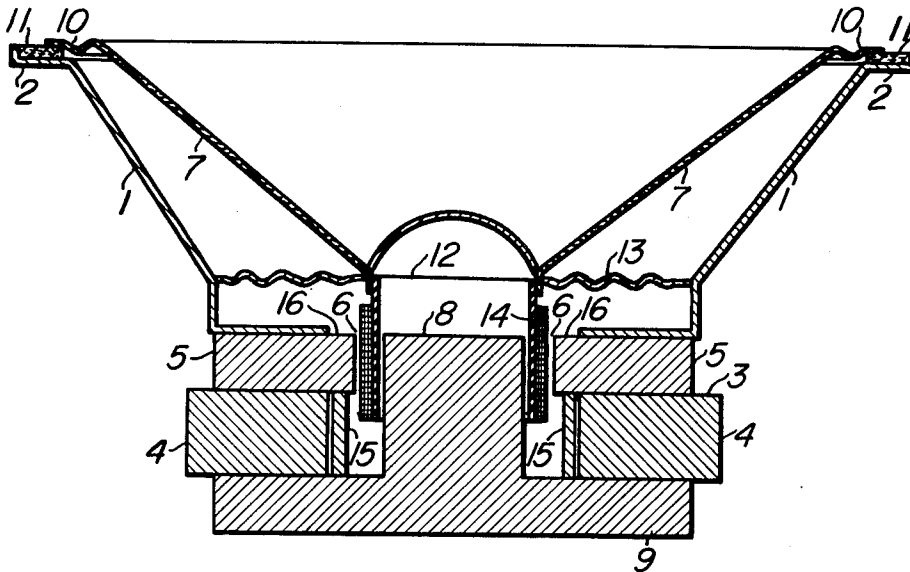

FIG. 1

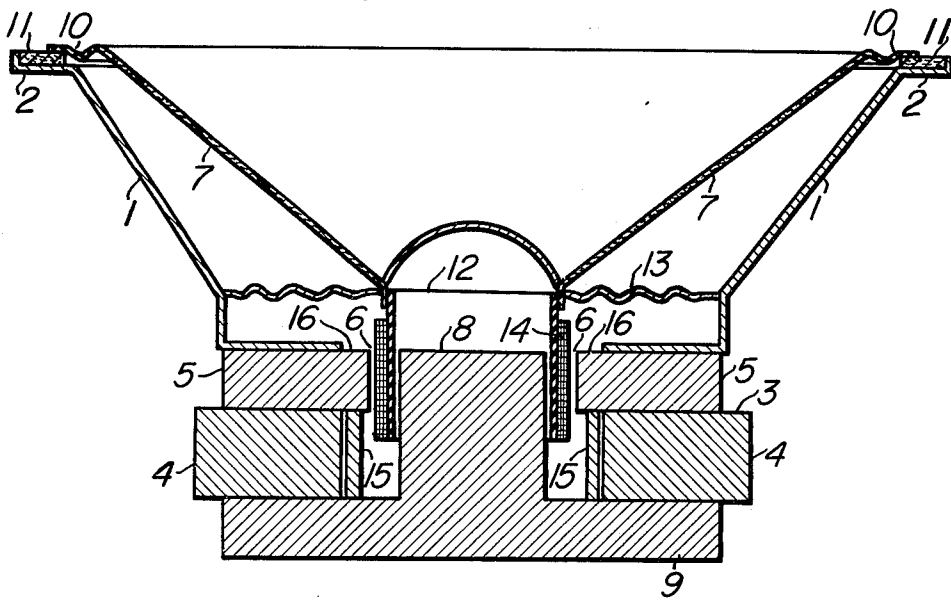

FIG. 2

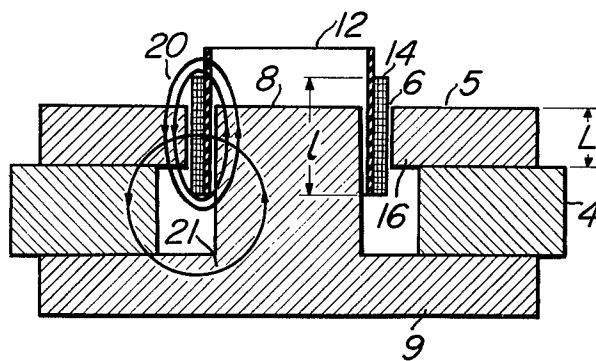

FIG. 3

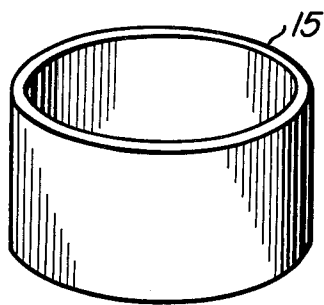
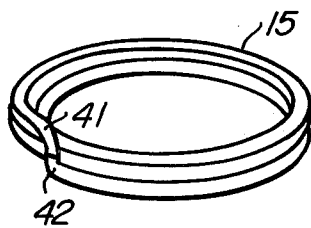

FIG. 4



## ELECTRO-ACOUSTIC TRANSDUCER

This invention relates to electro-acoustic transducers commonly known as loudspeakers and more particularly to an electro-acoustic transducer preferably used as a high fidelity loudspeaker which generates a large acoustic output in response to the application of a large input signal.

An electro-acoustic transducer which is connected to a radio receiver or an audio amplifier for converting an electrical audio signal into an acoustic signal is required to operate satisfactorily with or accept a large input signal and to generate a large acoustic output in response to such input. Further, it is desirable that such an electro-acoustic transducer generates an acoustic output which is free from distortions over the entire range of the reproduced frequency band.

The sound pressure of an acoustic output signal obtained by the vibration of the diaphragm of an electro-acoustic transducer is proportional to the acceleration imparted to the diaphragm during vibration, and the diaphragm and voice coil vibrate with an increased amplitude when a large input signal is applied. Therefore, in order that the electro-acoustic transducer can operate satisfactorily in response to the application of a large input signal, the diaphragm and voice coil must be such that these elements are free from any breakdown even when vibrated with a large amplitude. The diaphragm is capable of vibrating with a large amplitude when the shape and material thereof are suitably selected so that its edge portion can make a sufficient expanding and contracting movement. The voice coil can be adapted to deal with vibrations of large amplitude by selecting its axial length to be sufficiently greater than the axial length of the magnetic flux gap defined between the magnet and the yoke so that it may not escape or move out of the magnetic flux gap even when subjected to vibrations of large amplitude.

However, when the voice coil is constructed to have a large axial length, an a.c. magnetic flux emanating from this voice coil passes through the magnetic circuit consisting of the magnet and the yoke thereby producing second harmonic distortions in the input signal current flowing through the voice coil, with the result that the acoustic output signal reproduced by the electro-acoustic transducer includes many second harmonic distortions. This phenomenon appears more markedly when a magnet of ferrite is used in the magnetic circuit than when a magnet of aluminum-nickel-cobalt alloy is used in the magnetic circuit. Thus, an attempt to increase the axial length of the voice coil in an electro-acoustic transducer employing a ferrite magnet is unsuccessful and such electro-acoustic transducer cannot be practically used due to the fact that many second harmonic distortions are involved in the acoustic output.

It is therefore necessary to prevent undesirable appearance of second harmonic distortions in an electro-acoustic transducer in which a voice coil having a large axial length is incorporated so that the transducer can bear or accept a large input signal and generate a large acoustic output signal.

It is an object of the present invention to provide an electro-acoustic transducer which can operate satisfactorily in response to the application of a large input signal and whose acoustic output is substantially free from undesirable distortions.

Another object of the present invention is to provide an electro-acoustic transducer which employs a voice coil having a large axial length and whose acoustic output is substantially free from second harmonic distortions.

A further object of the present invention is to provide an electro-acoustic transducer in which a ferrite magnet is used in the magnetic circuit, which employs a voice coil having a large axial length and whose acoustic output is substantially free from second harmonic distortions.

The electro-acoustic transducer according to the present invention is featured by the fact that it comprises a pole piece, a yoke disposed in the vicinity of the upper end portion of the pole piece and having a magnetic pole portion facing the pole piece while defining an annular magnetic flux gap therebetween, a magnet magnetically coupled to the pole piece and the yoke, a voice coil inserted in the magnetic flux gap, the voice coil having a large axial length compared with the thickness of the magnetic pole portion of the yoke, a diaphragm operatively connected to the voice coil, and a short-circuit ring of metal material such as copper or aluminum disposed around the pole piece so as to cancel the portion of a.c. magnetic flux emanating from the voice coil and circulating through the magnetic circuit including the yoke, the magnet and the pole piece thereby preventing undesirable appearance of second harmonic distortions in the acoustic output signal.

In the electro-acoustic transducer according to the present invention which incorporates a voice coil having such an increased axial length to deal with a large input signal, application of a large input signal for the purpose of reproduction of a large acoustic output would not result in undesirable appearance of second harmonic distortions in the acoustic output from the electro-acoustic transducer due to the fact that the a.c. magnetic flux emanating from the voice coil and circulating through the magnetic circuit can be cancelled by the short-circuit ring. Further, even when the magnet is of ferrite, the unnecessary a.c. magnetic flux giving rise to second harmonic distortions can be cancelled so that a substantially distortion-free acoustic output can be obtained.

Other objects, features and advantages of the present invention will be apparent from the following detailed description of a preferred embodiment thereof taken in conjunction with the accompanying drawings, in which:

FIG. 1 is an axial section of an embodiment of the electro-acoustic transducer according to the present invention;

FIG. 2 is an axial section of driving parts of the electro-acoustic transducer, illustrating the flow of a.c. magnetic flux emanating from the voice coil;

FIG. 3 is an enlarged perspective view of one form of the short-circuit ring; and

FIG. 4 is an enlarged perspective view of another form of the short-circuit ring.

A preferred embodiment of the electro-acoustic transducer according to the present invention will now be described with reference to FIG. 1. Referring to FIG. 1, a generally frusto-conical frame 1 is provided with a flange portion 2 along the outer periphery of one of the open ends, and a magnetic circuit 3 is mounted on the other end having a central opening. The magnetic circuit 3 is composed of an annular magnet 4 hav-

ing a central opening, an annular first yoke 5 bonded or otherwise fixed to the upper surface of the magnet 4 and having a central circular magnetic pole portion 16, a pole piece 8 inserted in the central opening of the magnet 4 opposite to the magnetic pole portion 16, and a second yoke 9 bonded or otherwise fixed to the lower surface of the magnet 4. The outer peripheral surface of the pole piece 8 is suitably spaced from the inner wall surface of the central opening of the first yoke 5 to define a magnetic flux gap 6 therebetween. The magnet 4 is made of ferrite, but it may be made of an aluminum-nickel-cobalt alloy.

A generally frusto-conical diaphragm 7 is corrugated at the outer peripheral edge portion at one end thereof as shown by 10, and this corrugated edge portion 10 is bonded or otherwise fixed to an annular sheet of cardboard 11 secured to the flange portion 2 of the frame 1. A voice coil bobbin 12 is inserted in the magnetic flux gap 6 in the magnetic circuit 3 and is bonded or otherwise fixed at its upper end to the other end of the diaphragm 7. Further, the diaphragm 7 is connected to a spider 13 which is secured to the frame 1. The corrugated edge portion 10 of the diaphragm 7 and the spider 13 are flexibly pliable so that the diaphragm 7 can vibrate freely. The voice coil bobbin 12 is in the form of an elongated cylinder extending downwardly beyond the lower end of the magnetic flux gap 6 defined between the pole piece 8 and the first yoke 5, and a voice coil 14 is wound around the bobbin 12. The voice coil 14 has a large axial length so that it extends downwardly beyond the lower end of the magnetic flux gap 6. The axial length of the voice coil 14 is sufficiently large compared with the thickness of the first yoke 5 so that the voice coil 14 may not escape or move out of the magnetic flux gap 6 even when a large input signal is supplied thereto. A short-circuit ring 15 of cylindrical shape made of metal material such as aluminum or copper is disposed in the central opening of the magnet 4 and is bonded or otherwise secured to the first and second yokes 5 and 9.

The state of flow of magnetic flux through the magnetic circuit in the electro-acoustic transducer employing such a voice coil will be described with reference to FIG. 2 before describing the operation of the electro-acoustic transducer having such a construction. Referring to FIG. 2, the voice coil 14 disposed in the magnetic flux gap 6 defined between the first yoke 5 and the pole piece 8 has an axial length  $l$  which is sufficiently large compared with the length  $L$  of the magnetic flux gap 6, hence the thickness of the magnetic pole portion 16 of the first yoke 5. In response to the application of an audio signal from, for example, a radio receiver or an audio amplifier to the voice coil 14, an a.c. magnetic flux emanates from the voice coil 14. This a.c. magnetic flux portion 20 which circulates around the voice coil 14 and another magnetic flux portion 21 which passes through the first yoke 5, magnet 4, second yoke 9 and pole piece 8 to circulate through the magnetic circuit 3. The magnetic flux portion 21 circulating through the magnetic circuit 3 appears when the axial length  $l$  of the voice coil 14 is greater than the length  $L$  of the magnetic flux gap 6, and it increases with the increase in the axial length of the voice coil 14. Since this magnetic flux portion 21 passes through the interior of the first and second yokes 5 and 9 and the pole piece 8 which are biased by a d.c. magnetic field, the magnetic flux portion 21 is distorted

due to the non-linear properties of the first yoke 5, pole piece 8 and second yoke 9 thereby producing second harmonic distortions in the audio signal current supplied to the voice coil 14. The second harmonic distortions appear more in the audio signal current when the magnet 4 is made of ferrite than when the magnet 4 is made of an aluminum-nickel-cobalt alloy for the two reasons described below. In the first place, the appearance of such distortions depends upon the degree of saturation of the magnetic paths in the magnetic circuit. The experiment made by the inventor has proved that less second harmonic distortions appear when the density of magnetic flux passing through the first and second yokes 5 and 9 is sufficiently high to an extent that these yokes 5 and 9 are nearly saturated. However, the operating d.c. magnetic flux density for the magnet 4 when made of an aluminum-nickel-cobalt alloy is of the order of 10,000 gauss, whereas that for the magnet 4 when made of ferrite is of the order of 3,000 gauss. The magnetic flux density for the first and second yokes 5 and 9 engaging the magnet 4 is naturally equal to the operating d.c. magnetic flux density for the magnet 4 although its value differs depending on the material of the magnet 4. Thus, when the magnet 4 is made of ferrite, the yokes 5 and 9 are not saturated and the second harmonic distortions appear in a greater degree. In the second place, the a.c. reluctance of the magnetic circuit is low when the magnet 4 is made of ferrite compared with the a.c. reluctance of the magnetic circuit when the magnet 4 is made of the aluminum-nickel-cobalt alloy. Thus, more a.c. magnetic flux flows through the magnetic circuit when the magnet 4 is made of ferrite.

Describing in more detail, the ferrite magnet and the magnet of aluminum-nickel-cobalt alloy used in the magnetic circuit have different shapes depending on their magnetic properties. Generally, the ferrite magnet is shaped to have a large surface area and a small thickness, while the magnet of aluminum-nickel-cobalt alloy is shaped to have a small surface area and a large thickness.

The magnetic reluctance  $R_m$  of the magnetic circuit against an a.c. magnetic field is given by the following equation:

$$R_m = lm/\mu_r \cdot s_m \quad (1)$$

where  $\mu_r$  is the reversible permeability,  $s_m$  is the surface area, and  $lm$  is the length of the magnetic circuit.

When the ferrite magnet is used in the magnetic circuit, the reversible permeability is approximately equal to 1 since the ferrite magnet has a small thickness and a large surface area. When, on the other hand, the magnet of aluminum-nickel-cobalt alloy is used in the magnetic circuit, the reversible permeability is approximately equal to 4 since this magnet has a small surface area and a large thickness. Thus, the magnetic reluctance  $R_m$  in the former case is lower than the magnetic reluctance  $R_m$  in the latter case, and an increased amount of a.c. magnetic flux circulates through the magnetic circuit resulting in an increase in the second harmonic distortions.

Further, with an increase in the density of the a.c. magnetic flux flowing in superposed relation with the d.c. magnetic flux, a second harmonic distortion component appears in the force driving the voice coil even

when any distortion component is not included in the current flowing through the voice coil. More precisely, the density  $B_{AC}$  of the a.c. magnetic flux flowing through the magnetic circuit is proportional to the current flowing through the voice coil and is given by the following equation:

$$B_{AC} = A \cdot I \cos \omega t \quad (2)$$

where  $A$  is a constant, and  $I$  is the current flowing through the voice coil. The force  $F$  acting upon the voice coil is given by the following equation:

$$\begin{aligned} F &= Bg \cdot l \cos \omega t \\ &= (B_{DC} + A \cdot I \cos \omega t) \cdot l \cos \omega t \\ &= B_{DC} \cdot l \cos \omega t + A \cdot l / 2 I^2 + A \cdot l / 2 I^2 \cos 2 \omega t \end{aligned} \quad (3)$$

where  $Bg$  is the magnetic flux density in the magnetic flux gap,  $B_{DC}$  is the d.c. magnetic flux density, and  $l$  is the effective length of the voice coil. It will be seen from the equation (3) that a force proportional to the second power of the current value is imparted to the voice coil due to the second harmonic distortion component.

Thus, the increase in the axial length of the voice coil results in the appearance of second harmonic distortions due to the fact that the a.c. magnetic flux portion 21 emanating from the voice coil flows through the magnetic circuit. Therefore, the a.c. magnetic flux portion 21 circulating through the magnetic circuit may be suitably cancelled in order to prevent undesirable appearance of the second harmonic distortions. In the present invention, the short-circuit ring 15 of metal material such as aluminum or copper is disposed in the space between the first and second yokes 5 and 9 as seen in FIG. 1 in order to cancel this undesirable magnetic flux portion 21.

In the electro-acoustic transducer shown in FIG. 1, an a.c. magnetic flux portion circulating around the voice coil 14 and another a.c. magnetic flux portion passing through the first yoke 5, magnet 4, second yoke 9 and pole piece 8 to circulate through the magnetic circuit 3 emanate from the voice coil 14 in response to the supply of an audio signal current to the voice coil 14 as previously described. The a.c. magnetic flux portion 21 flows across the short-circuit ring 15 thereby inducing a counter electromotive force in the ring 15. The short-circuit ring 15 is equivalent to a coil having a single turn and the counter electromotive force induced in the ring 15 causes a current to flow therein thereby producing a magnetic flux. The magnetic flux emanating from the short-circuit ring 15 flows in a direction opposite to the direction of flow of the magnetic flux portion 21 which emanates from the voice coil 14 and circulates through the magnetic circuit. Thus, this magnetic flux cancels the a.c. magnetic flux portion 21 emanating from the voice coil 14 and circulating through the magnetic circuit. By the provision of the short-circuit ring 15, it is possible to remove undesirable distortions appearing in the audio signal current due to the non-linear properties of the first and second yokes 5 and 9 and to remove the force acting upon the voice coil 14 due to the distortion component. Thus, the electro-acoustic transducer can deliver a large acoustic output which is substantially distortion-free.

FIGS. 3 and 4 show preferred forms of the short-circuit ring 15 disposed around the pole piece 8 adja-

cent to the magnet 4. The short-circuit ring 15 shown in FIG. 3 is formed in a cylindrical shape from a plate of metal such as aluminum or copper. This short-circuit ring 15 is so sized that its inner diameter is larger than the outer diameter of the pole piece 8 and its outer diameter is smaller than the diameter of the central opening of the magnet 4. This short-circuit ring 15 can be easily made by cutting an elongated pipe of metal such as aluminum or copper into predetermined lengths. The short-circuit ring 15 shown in FIG. 4 is made by coiling a large-diameter wire of metal such as aluminum or copper over a plurality of turns and connecting the starting end 41 of the coil convolutions to the terminating end 42.

It will be understood from the foregoing description that the present invention provides a useful electro-acoustic transducer in which, in spite of the fact that a voice coil having a large axial length is employed, an unnecessary a.c. magnetic flux emanating from the voice coil can be effectively cancelled to prevent occurrence of undesirable distortions. Therefore, the electro-acoustic transducer can deliver a large acoustic output in response to a large input signal and undesirable distortions appearing in the acoustic output signal can be minimized.

What is claimed is:

1. An electro-acoustic transducer comprising a pole piece, a yoke having a magnetic pole portion facing said pole piece while defining an annular magnetic flux gap therebetween a magnet magnetically coupled to said pole piece and said yoke, a voice coil inserted in said magnetic flux gap, said voice coil having a large axial length compared with the thickness of said magnetic pole portion of said yoke, an annular conductive short-circuit ring disposed concentrically around said pole piece between said magnet and said pole piece, and a diaphragm operatively connected to said voice coil, whereby the magnetic coupling between said magnet and said pole piece caused by the large axial length voice coil is cancelled by said short-circuit ring.

2. An electro-acoustic transducer as claimed in claim 1, in which said short-circuit ring disposed around said pole piece is made by forming a metal plate into a cylindrical shape.

3. An electro-acoustic transducer as claimed in claim 1, in which said short-circuit ring disposed around said pole piece is made by winding a metal wire into a coil form and connecting the starting and terminating ends of the wire forming the coil convolutions.

4. An electro-acoustic transducer as claimed in claim 1, wherein said short-circuit ring is of a material selected from the group consisting of aluminium and copper.

5. An electro-acoustic transducer as claimed in claim 1, wherein said magnet is of a material selected from the group consisting of aluminium-nickel-cobalt alloy and a ferrite.

6. An electro-acoustic transducer as claimed in claim 1, further comprising means for causing an A.C. magnetic flux to emanate from the voice coil wherein the portion of the A.C. magnetic flux circulating through the magnet and said pole piece is cancelled by said short-circuit ring.

7. An electro-acoustic transducer comprising: an annular ferrite magnet having an opening formed in a central portion of said annular magnet;

7

8

a first annular yoke bonded to one surface of said ferrite magnet and having a circular magnetic pole in a central annular opening of said first yoke;  
 a pole piece disposed in the central opening of said magnet and being concentrically surrounded by said magnetic pole of said first yoke defining an annular magnetic flux gap therebetween;  
 a second yoke bonded to an opposite surface of said magnet from said one surface and connected to said pole piece;  
 a voice coil bobbin operatively disposed in said magnetic flux gap between said first yoke and said pole piece;  
 a voice coil wound on said bobbin and having an axial length greater than the thickness of said magnetic pole of said first yoke;

5  
10  
15

an annular short-circuit ring of non-magnetic material disposed concentrically between said pole piece and said magnet and bonded to said first and second yokes; and  
 a diaphragm operatively connected to said voice coil bobbin.

8. An electro-acoustic transducer as claimed in claim 7, in which said short-circuit ring disposed around said pole piece is made by forming a metal plate into a cylindrical shape.

9. An electro-acoustic transducer as claimed in claim 7, in which said short-circuit ring disposed around said pole piece is made by winding a metal wire into a coil form and connecting the starting and terminating ends of the wire forming the coil convolutions.

\* \* \* \* \*

20

25

30

35

40

45

50

55

60

65