

(19) World Intellectual Property Organization
International Bureau



(43) International Publication Date
15 August 2002 (15.08.2002)

PCT

(10) International Publication Number
WO 02/063349 A2

- (51) International Patent Classification⁷: G02B
- (21) International Application Number: PCT/US02/03356
- (22) International Filing Date: 1 February 2002 (01.02.2002)
- (25) Filing Language: English
- (26) Publication Language: English
- (30) Priority Data:
60/265,605 2 February 2001 (02.02.2001) US
- (71) Applicant (for all designated States except US): RESEARCH INTERNATIONAL, INC. [US/US]; 18706 142nd Avenue, Woodinville, WA 98072 (US).

- (81) Designated States (national): AE, AG, AL, AM, AT, AU, AZ, BA, BB, BG, BR, BY, BZ, CA, CH, CN, CO, CR, CU, CZ, DE, DK, DM, DZ, EC, EE, ES, FI, GB, GD, GE, GH, GM, HR, HU, ID, IL, IN, IS, JP, KE, KG, KP, KR, KZ, LC, LK, LR, LS, LT, LU, LV, MA, MD, MG, MK, MN, MW, MX, MZ, NO, NZ, OM, PH, PL, PT, RO, RU, SD, SE, SG, SI, SK, SL, TJ, TM, TN, TR, TT, TZ, UA, UG, US, UZ, VN, YU, ZA, ZM, ZW.
- (84) Designated States (regional): ARIPO patent (GH, GM, KE, LS, MW, MZ, SD, SL, SZ, TZ, UG, ZM, ZW), Eurasian patent (AM, AZ, BY, KG, KZ, MD, RU, TJ, TM), European patent (AT, BE, CH, CY, DE, DK, ES, FI, FR, GB, GR, IE, IT, LU, MC, NL, PT, SE, TR), OAPI patent (BF, BJ, CF, CG, CI, CM, GA, GN, GQ, GW, ML, MR, NE, SN, TD, TG).

- (72) Inventor; and
- (75) Inventor/Applicant (for US only): SAASKI, Elric, W. [US/US]; 24133 - 39th Avenue S.E., Bothell, WA 98021 (US).
- (74) Agent: RENZONI, George, E.; Christensen O'Connor Johnson Kindness PLLC, Suite 2800, 1420 Fifth Avenue, Seattle, WA 98101 (US).

Published:
— without international search report and to be republished upon receipt of that report

For two-letter codes and other abbreviations, refer to the "Guidance Notes on Codes and Abbreviations" appearing at the beginning of each regular issue of the PCT Gazette.

(54) Title: ENHANCED WAVEGUIDE AND METHOD

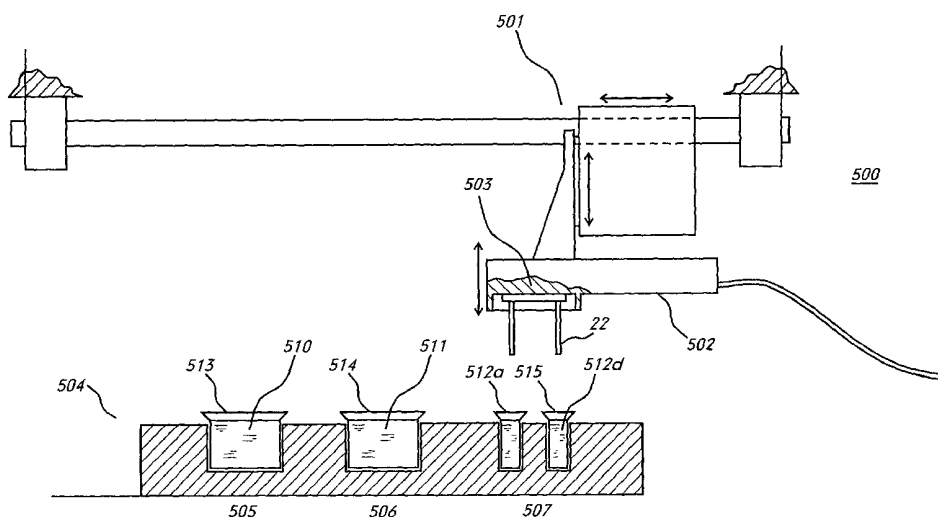

(57) Abstract: The present invention provides an optical assay apparatus that includes a light source module and an optical sensor. The light source module produces light having a range of propagation angles. The sensor includes a light adjusting portion and an assay sensing portion. The light adjusting portion receives the light produced by the light source module and provides light having a propagation angle that is substantially constant to the assay sensing portion. In one embodiment, the sensor may be coupled with the light source module by an interrogation module which includes a window in which a waveguide is integrated. In another embodiment, the sensor and interrogation module are mounted in an automated assay platform that provides two-dimensional or three-dimensional movement of the sensor so that it can be sequentially immersed in solutions required to perform a particular assay protocol. While the sensor is immersed in a particular liquid, the system provides oscillatory movement of the sensor and/or rotary movement of the contacted liquid to increase evanescent wave region reaction rates with targeted analytes and/or reagents.



WO 02/063349 A2

ENHANCED WAVEGUIDE AND METHOD FIELD OF THE INVENTION

This invention relates generally to optical methods and apparatus for chemical and biochemical assays, and more particularly to fiber optics-based methods and apparatus for
5 such assays.

BACKGROUND OF THE INVENTION

There exists a need for a highly sensitive and specific technology directed to the detection of human pathogens and toxins in food, water, and the environment. It is very difficult to effectively detect organisms in natural fluids such as milk, blood, sewage and
10 meat products at low concentration and to discriminate between pathogenic and harmless species. Conventional bioassay methods are commonly designed for samples on the order of a few cubic centimeters, and the extraction or concentration of pathogenic material from larger volumes to meet sensitivity requirements creates additional challenges.

One of the most promising strategies for performing pathogen assays on raw,
15 unpurified samples is based on sensors that harness biological ligand-receptor interactions to identify specific compounds. Examples of approaches that implement such a strategy include fiber optic evanescent wave sensors and surface plasmon resonance sensors.

An electromagnetic wave, traveling through one material, that is reflected at a dielectric interface produces an exponentially decaying electric field within the second
20 material on the opposite side of the interface. At optical frequencies this is termed the evanescent wave effect, and at radio frequencies this phenomenon is often called a "skin effect." The penetration depth within the second material, the evanescent wave region, is a small fraction of a wavelength, yet greater in size than most optical labels 100 such as light- or fluorescence-producing reporter molecules, light-absorbing or scattering
25 molecules, and colloidal particles and microspheres. These labels can be used to monitor or produce optical changes in the evanescent region, or modify the propagation of light in the adjacent dielectric, providing a fundamental means of detecting target materials that are close to the surface while discriminating against those far away. In particular, by coating the interface with a capture agent that is specific for a microscopic or molecular
30 target of interest, exquisitely sensitive optical-based sensors can be created.

In one competitive assay technique, fluorophore-labeled antigen 104, together with the sample to be tested, is exposed to the coating of capture antibody on the fiber, and the labeled antigen competes for antibody binding sites with non-tagged analyte 106

in the test sample. The evanescent field produced by light 108 passing through the fiber 102 then excites the fluorophores into light emission 110, and the fiber itself conveniently acts as a return waveguide for the fluorescent signal. In this example, the strength of the fluorescent signal is inversely related to the analyte concentration in the test sample.

5 Alternatively, a non-competitive technique, such as a sandwich-format assay, can be used, in which case the fluorescent signal is directly related to the analyte concentration in the test sample. High sensitivity and specificity can be achieved for a wide range of metals, toxins, proteins, viruses, living and dead bacteria, and spores, through the use of bound target-specific agents 100 such as chelating agents, antibodies, crown ethers and

10 the like, combined with appropriate optical labels that luminesce, fluoresce or alter light transport by the waveguide. In applications where pathogens will be infrequently found, cost per assay may be low since the sensor remains active until the capture agents have been substantially neutralized by the binding of the target material.

For surface plasmon resonance sensing, FIGURE 1B shows a thin layer of metal

15 110, such as gold, applied to a core portion 112 of an optical fiber 114 from which the cladding 116 of the fiber has been partly removed. The evanescent electric field produced by light 118 passing through the fiber 114 excites surface plasmon waves 120 on the outer surface of the metal 110. When white light is passed through the fiber 114, the excitation of a surface plasmon wave causes a dip in the spectrum of the light passing

20 through the fiber, with the dip occurring at a resonance wavelength which is a function of the complex indices of refraction of the fiber core, the metal layer, and the solution surrounding the fiber, as well as the incidence angle of the light. Light passing through the fiber 114 can be returned by a mirror 122, or can be passed through the distal end of the fiber (in the absence of a mirror) for optical processing and analysis, as is well known

25 to those skilled in the art. Any change in the index of refraction of the solution is detectable, and molecules binding to the surface of the metal 110 can then be detected if they have an index of refraction that is different from the bulk solution. Coating the metal layer 110 with target-specific capture molecules (not shown), which react with target analytes within a sample solution, then allows detection of reactions (such as antigen-antibody reactions and reduction-oxidation reactions) on the surface of the metal.

30

Fiber optic evanescent wave sensors are the subject of a number of U.S. patents, including the following, the disclosures of each being incorporated herein by reference: U.S. Pat. No. 4,447,546, to Hirschfeld et al., entitled "Fluorescent Immunoassay

Employing Optical Fiber in Capillary Tube"; U.S. Pat. No. 4,558,014, to Hirschfeld et al.,
entitled "Assay Apparatus and Method"; U.S. Pat. No. 4,582,809, to Block et al., entitled
"Apparatus Including Optical Fiber for Fluorescence Immunoassay"; U.S. Pat. No.
4,654,532, to Hirschfeld, entitled "Apparatus for Improving the Numerical Aperture at
5 the Input of a Fiber Optic Devices"; U.S. Pat. No. 4,716,121, to Block et al., entitled
"Fluorescent Assays, Including Immunoassays, with Feature of Flowing Sample"; U.S.
Pat. No. 4,909,990, to Block et al., entitled "Immunoassay Apparatus"; U.S. Pat. No.
5,242,797, to Hirschfeld, entitled "Nucleic Acid Assay Method"; U.S. Pat. No. 5,061,857,
to Thompson et al., entitled "Waveguide-Binding Sensor for Use With Assays"; U.S. Pat.
10 No. 5,430,813, Anderson et al., entitled "Mode-Matched, Combination Taper Fiber Optic
Probe"; U.S. Pat. No. 5,152,962, to Lackie, entitled "Immunoassay Apparatus"; U.S. Pat.
No. 5,290,398, to Feldman et al., entitled "Synthesis of Tapers for Fiber Optic Sensors";
and U.S. Pat. No. 5,399,866, to Feldman et al., entitled "Optical System for Detection of
Signal in Fluorescent Immunoassay." Fiber optic surface plasmon resonance sensors are
15 the subject of U.S. Pat. No. 5,359,681 to Jorgenson et al., entitled "Fiber Optic Sensor
and Methods and Apparatus Relating Thereto," the disclosure of which is incorporated
herein by reference.

For evanescent wave sensors, it is desirable to optimize the magnitude of the
evanescent electric field as well as to optimize the optical properties of the return path for
20 the detected fluorescence. The above-identified patents describe numerous optimization
approaches, including attempts to match the numerical aperture of various system
components and to improve system numerical aperture. Numerical aperture is a measure
of the largest angle, relative to the optical axis of a system, that a ray of light can have
and still pass through the system. Each component in an optical system will have its own
25 unique limiting numerical aperture, and the maximum system numerical aperture will be
determined by the system component having the lowest numerical aperture. The system
numerical aperture is a key parameter in optical sensing since transferred power is
typically proportional to its square. Good design practice and cost efficiencies require
system components to have matching numerical apertures.

30 One well-known approach of matching numerical apertures employs tapered or
cone-shaped waveguides. In addition to providing numerical aperture matching, tapering
the active, analyte-sensitive portion of the optical fiber maintains a substantial fraction of
the input light near the critical angle, thereby maintaining a high magnitude evanescent

field. However, there is also a constant loss of light along the sensor fiber as the taper acts upon rays that are already only weakly guided and causes them to exceed the critical angle.

In order for white light to propagate in an optical fiber used in connection with a surface plasmon resonance sensor, the fiber must have a large enough diameter to support the longest wavelength of light. Also, a large diameter fiber propagates higher numerical aperture light, which makes it easier to excite surface plasmon waves in metal films of a thickness readily fabricated by conventional processes. As a consequence, multi-mode fibers are used which propagate light over a range of angles. However, this range of angles results in a less distinct resonance effect, because each angle of propagation results in a different resonance wavelength.

FIGURE 2A shows the theoretical resonance curves for various propagation angles relative to the optical axis of the fiber core, assuming a 55 nm thick layer of gold on a silica optical fiber core immersed in water. The overall resonance detected is a superposition of the resonance effects for each of the various angles of propagation. FIGURE 2B shows the integration of individual theoretical resonance curves for propagation angles from 0 to 23.6 degrees, assuming a sine-squared distribution of optical power at the various propagation angles. The significant signal degradation associated with current approaches to surface plasmon resonance sensing is seen by comparing the resonance curve of FIGURE 2B with the individual resonance curve of, for example, 23.6 degrees in FIGURE 2A.

The first evanescent waveguide sensors, described in the early 1980's, were for substantially cylindrical waveguides, that is, waveguides with circular cross-sections in which light uniformly filled the entire cross-sectional area. Recent development has strongly emphasized planar waveguides excited by collimated light beams. In these devices, light is only contained in one dimension and lateral spreading is totally defined by excitation optics. This substantial shift has occurred primarily due to an interest in creating multianalyte assay arrays by printing a linear or two-dimensional pattern of capture agent spots on one surface of the planar waveguide within the illumination path of the light beam, and then monitoring for an optical signal from individual analyte-specific spots with a CCD detector array or photomultiplier on the other side of the slab waveguide.

However, the planar approach has some other weaknesses in addition to its limited light guiding ability. Due to the typically small size of individual assay spots it is a challenge to effectively contact each dot with the entire fluid sample. This is of particular significance when foodstuffs are tested for pathogens. Regulations may require, because of high health risks at extremely low pathogen levels, that assay samples of 300 cubic centimeters or more be utilized. By way of example, the acceptance limit set by the US Department of Agriculture for *Escherichia coli* O157:H7 is one organism per 25 gm of sample. It is very difficult to effectively detect organisms at such a low concentration with methods based on bioassay dots of typically 1 mm² or less area. In addition, sample heterogeneity becomes an issue when raw food samples are examined. Fat globules and other non-toxic components may adhere non-specifically to the sensor or physically block contact with the target, reducing the effective sensitivity. Samples may also be viscous which increases the mass transfer boundary layer thickness and decreases the diffusive mass transport rates. These factors may yield low signal levels and create poor assay statistics where the target is a low, yet lethal concentration of a human or animal pathogen.

Analyte mass-diffusion boundary layers are also typically thicker for planar structures than for solids of revolution, such as cylinders. For related reasons a planar geometry may be more difficult to clean if the assay involves a multi-step protocol such as a sandwich immunoassay, or if it is desired to reuse the sensor. Finally, for applications such as food safety the number of target pathogens may be only one to six, calling into question the value of low sensitivity array techniques that require sophisticated and possibly costly CCD or photomultiplier signal recovery techniques.

Although evanescent wave and surface plasmon resonance sensors show great promise for use in medical and food safety applications, those skilled in the art understand that the current technology is less than optimal in a number of respects, including those disadvantages identified above.

SUMMARY OF THE INVENTION

In accordance with the present invention, an optical assay apparatus includes a light source module and an optical sensor. The light source module produces light having a range of propagation angles. The sensor includes a light adjusting portion and an assay sensing portion. The light adjusting portion receives the light produced by the light source

module and provides light having a propagation angle that is substantially constant to the assay sensing portion.

In one embodiment, the light source module produces light having propagation angles ranging from a lower, non-zero limit. This may be accomplished by including an obscuration which blocks light having propagation angles below this limit. In one
5 embodiment, the light adjusting portion of the sensor may include a reflector which receives, as incident light, the light produced by the light source module and produces, as reflected light, the light having a substantially constant propagation angle. The assay sensing portion of the sensor may be a waveguide coated with sensor molecules suitable
10 for performing evanescent wave sensing operations, or may be a waveguide coated with a thin metallic film suitable for performing surface plasmon resonance sensing operations.

In one embodiment, the sensor may be coupled with the light source module by an interrogation module which includes a window in which a waveguide is integrated. The waveguide transmits the light produced by the light source module to the sensor. The
15 waveguide may be an optical fiber with an angled end having a reflective surface to create a right-angle reflector. The waveguide may be embedded in the window in a slot containing an opaque material to prevent back-scattering of excitation light from the waveguide into optical components included within the interrogation module.

In one embodiment, the sensor and interrogation module are mounted in an automated assay platform that provides two-dimensional or three-dimensional movement
20 of the sensor so that it can be sequentially immersed in solutions required to perform a particular assay protocol. While the sensor is immersed in a particular liquid, the system provides oscillatory movement of the sensor and/or rotary movement of the contacted liquid to increase evanescent wave region reaction rates with targeted analytes and/or
25 reagents.

BRIEF DESCRIPTION OF THE DRAWINGS

The foregoing aspects and many of the attendant advantages of this invention will become more readily appreciated as the same become better understood by reference to the following detailed description, when taken in conjunction with the accompanying
30 drawings, wherein:

FIGURE 1A depicts an optical fiber adapted for use in evanescent wave sensing operations in accordance with the prior art.

FIGURE 1B depicts an optical fiber adapted for use in surface plasmon resonance sensing operations in accordance with the prior art.

FIGURES 2A and 2B are graphs which depict theoretical resonance curves associated with use of the optical fiber of FIGURE 1B in surface plasmon resonance
5 sensing operations in accordance with the prior art.

FIGURE 3 is a functional block diagram which depicts an assay system in accordance with an embodiment of the present invention.

FIGURE 4 depicts a portion of a light source module included in the assay system of FIGURE 3.

10 FIGURE 5 is a graph which depicts the improved light distribution provided by the light source module of FIGURE 4.

FIGURE 6A depicts a portion of an optical interrogation module and of an optical sensing element included in the system of FIGURE 3, and shows an excitation light path.

15 FIGURE 6B depicts the portions of the interrogation module and of the optical sensing element of FIGURE 6A, and shows a signal recovery light path.

FIGURE 7A is a side view which depicts an embodiment of an interrogation module window included in the optical interrogation module of FIGURE 6A.

FIGURE 7B is a front view of the interrogation module window of FIGURE 7A.

20 FIGURE 8 depicts the geometry of a reflector portion included in the optical sensing element of FIGURES 6A and 6B.

FIGURE 9 is an optical ray tracing which depicts the effect of the reflector portion of FIGURE 8 on excitation light rays directed at various angles.

FIGURE 10 is a graph which depicts the angular distribution of light rays acted on by the reflector portion of FIGURE 8.

25 FIGURE 11 identifies specific geometries of lens and reflector portions of an optical sensing element in accordance with a presently preferred embodiment of the invention.

FIGURE 12 is a graph which demonstrates the signal strengths associated with using different combinations of fluorophore and laser excitation wavelength.

30 FIGURE 13 is a graph which demonstrates the improved characteristics of a surface plasmon resonance sensor employing the optical sensing element of FIGURES 6A and 6B.

FIGURE 14 depicts an assay coupon including the optical sensing element of FIGURES 6A and 6B.

FIGURE 15 depicts an assay unit in which the assay coupon of FIGURE 12 may be inserted.

5 FIGURE 16 depicts a robotic platform for performing immersion-type assays with cylindrical and self-collimating waveguide sensors.

FIGURE 17 depicts a carrier plate for mounting an array of six waveguides onto the robotic platform.

10 FIGURE 18 depicts a 6-pocket reagent holder for performing automated waveguide assays.

FIGURE 19 depicts a contactless labyrinth seal to exclude exterior light from the waveguide array.

FIGURE 20 depicts a rotary sample stage for maximizing sample contact with the waveguides and enhancing mass transfer to the waveguide surfaces.

15 FIGURE 21 depicts an annular sample cup that allows higher rotational speeds and greater mass transfer enhancements by reducing fluid climb on the outermost cup wall.

FIGURE 22 depicts a multi-element sensor in accordance with an embodiment of the present invention.

20 DETAILED DESCRIPTION OF THE PREFERRED EMBODIMENT

An optical assay apparatus and method is described, with certain specific details set forth in order to provide a thorough understanding of various embodiments of the present invention. However, one skilled in the art will understand that the present invention may be practiced without these details. In other instances, well-known
25 structures and operations are not shown or discussed in detail in order to avoid obscuring the description of the embodiments of the invention.

FIGURE 3 is a functional block diagram which depicts an assay system 20. An optical sensing element 22 includes a lens portion 24, a reflector portion 26, and a sensing waveguide or fiber portion 28, as will be described in further detail below. The sensing
30 element 22 receives excitation light 30 and returns signal recovery light 32. The excitation light 30 is produced by a light source module 34, under control of a drive circuit 36. The light source module 34 provides the excitation light via a waveguide or optical fiber, such as source fiber 38. An interrogation module 40 receives the signal

recovery light 32, and can also advantageously optically couple the sensing element 22 with the excitation light 30 transmitted via the source fiber 38. The optical interrogation module 40 includes optical devices, such as lenses, and transducers, such as photodetectors, to produce an electrical signal functionally related to the signal recovery
5 light 32. The electrical signal is amplified by photo-current amplifier 42 which provides the amplified signal to a microcontroller 44. The microcontroller 44 then interprets the amplified signal, and provides the sensing operation results in the form of a readout or printout, or stores the results for later analysis. The microcontroller 44 also can control operation of the light source drive circuit 36.

10 Those skilled in the art will appreciate that the assay system depicted in FIGURE 3 is a simplified block diagram showing components whose configuration and function is well-known. Details concerning portions of the light source module 34, the optical interrogation module 40, and the sensing element 22 will be described below in connection with the various embodiments of the present invention. Further details
15 regarding the other functional blocks shown in FIGURE 3 need not be described herein for those skilled in the art to practice the present invention.

FIGURE 4 depicts a portion of the light source module 34 of FIGURE 3. The figure depicts a cross-section taken along an optical axis 45. A light source, such as a laser diode 46, is included within a source housing 48 having a window 50. The laser
20 diode 46 produces the excitation light 30 which is focused onto an end 51 of the source fiber 38 by a numerical aperture-adjusting lens 52. The source fiber 38 is held by an optical fiber ferrule 39 used for positioning the end 51 of the fiber at the focal point of the numerical aperture-adjusting lens 52. The source fiber 38 then transfers the excitation light to the sensing element 22, for example, as shown in FIGURE 3.

25 In one embodiment, the laser diode 46 is a commercially available visible laser diode in a standard 9 mm package, operating in the 600 nm to 700 nm waveband and producing an average power of about 1 mW or more. The numerical aperture-adjusting lens 52 is a 3 mm diameter, 0.25 pitch graded refractive index (GRIN) lens. The source fiber 38 is a 200 micron core-diameter optical fiber, which is preferably made of a
30 transmission material such as glass or quartz, since such material generates minimal self-fluorescence and has low scattering losses. However, plastic fibers or other waveguides may be suitable, especially if the distance from the light source module 34 to the sensing element 22 (see FIGURE 3) is less than a few meters. In this embodiment, the GRIN lens

transforms the approximately 0.4 to 0.6 numerical aperture of the laser diode 46 to approximately 0.22, in keeping with the comparatively low maximum numerical aperture of quartz fibers. A thin (approximately 0.15 mm) transparent glass disk 54 is bonded to the GRIN lens 52 by a transparent adhesive, and includes a circular obscuration 56 of approximately 0.75 mm diameter positioned symmetrically about the optical axis 45. The effect of the obscuration 56 is to eliminate low propagation angle rays from being input to the source fiber 38. If the source fiber 38 is not bent so severely as to promote internal mode conversion, and does not contain large numbers of scattering centers, then light exiting the fiber will have the same angular characteristics as light entering the fiber.

FIGURE 5 is a graph which shows measurements of the angular distribution of the light exiting from the source fiber 38, with and without the obscuration 56. These measurements correspond to the light source module 34 and source fiber 38 of the particular construction described above. Clearly, the obscuration 56 provides an angular distribution of light with the lower propagation angle rays largely removed, the advantage of which will become apparent in the discussion below. For purposes of convenient presentation, propagation angles relative to the optical axis 45 (see FIGURE 4) are represented as numerical aperture values in the graph of FIGURE 5.

FIGURE 6A shows the excitation light 30 passing through the source fiber 38 to a right-angle reflector 58 constructed on a distal end 59 of the fiber. The excitation light 30 then passes into the lens portion 24 of the sensing element 22, reflects off a reflective surface 27 of the reflector portion 26, and passes into the sensing fiber portion 28. The sensing fiber portion 28 may be a core portion of an optical fiber from which the cladding has been removed. Alternatively, the sensing fiber 28 may be a plastic fiber, or any of a variety of suitably adapted waveguide configurations.

FIGURE 6B depicts the return of signal recovery light 32, such as from evanescent field-induced fluorescence, through the sensing fiber 28, reflecting off the reflector 26, refracting through the lens 24, and passing into the interrogation module 40 (also see FIGURE 3) through an interrogation window 60. Once inside the interrogation module 40, the signal recovery light 32 is focused by a lens, such as a sapphire ball lens 62, onto a transducer, such as a photodetector 64.

FIGURE 7A shows greater details of one embodiment of the interrogation module window 60. The distal end 59 of the source fiber 38 is polished to a 45-degree mirror finish, and coated with a reflective film 61, to form the right-angle reflector 58. This

portion of the source fiber 38 is integrated within the interrogation module window 60, as described in detail herein. The right-angle reflector 58 is oriented so that light within the source fiber 38 emerges from the window 60 generally perpendicular to the window surface, with a numerical aperture of, for example, 0.22.

5 The interrogation module window 60 includes a laser-line rejection filter film 66 deposited onto one face of a glass plate 67. The primary function of the filter film 66 is to exclude any flare light associated with the excitation light 30 from reaching the optical components included within the interrogation module 40, while providing an unimpeded path for the longer wavelength fluorescent signal recovery light 32 (see FIGURES 6A
10 and 6B). The selection of an excitation source and blocking filter are intimately related to signal recovery and are discussed in that context at a later point. A circular obscuration feature 68 of, for example, approximately 1.5 mm diameter is painted or coated onto the exterior surface of the filter film 66. The obscuration 68 augments the filter film 66 by blocking any back-reflected excitation light 30 which might be reflected off the lens
15 portion 24 of the sensing element 22.

Referring to both FIGURES 7A and 7B, a groove 70 is cut into the glass plate 67 on the side opposite the filter film 66. This groove may be cut with a high-speed, water-cooled diamond saw. The slot 70 is then filled with a highly opaque material 72, such as
20 320 epoxy from Epoxy Technologies of Billerica, Mass. A second, narrower slot 74, equal to the width of the source fiber 38, is then made in the opaque material 72, taking care to position the slot 74 so that it does not break through the opaque material 72 at any point along the length of the slot 74. The source fiber 38 is then positioned in the slot 74 so that it is emitting light at the correct position and in the correct direction, and a thin
25 glass cover plate 76 is pressed against the groove window face to preserve the fiber's position. A transparent material, such as UV adhesive P92 from Summers Optical of Fort Washington, Pa., is then wicked into the void area surrounding the entrapped source fiber 38 to remove any air, and the adhesive is cured.

Both the adhesive and cover plate 76 should be selected to have refractive indices that are approximately the same as the cladding of the source fiber 38 to minimize
30 aberration in the projected beam. Since the excitation light 30 must, upon reflection from the right-angle reflector 58, pass through the cylindrical wall of the source fiber 38, the fiber's wall would otherwise act as a cylindrical lens and distort the shape of the emitted excitation light beam. The opaque material 72, together with the obscuration 68, absorbs

any excitation light spilled from defects in the mirror coating at the right-angle reflector 58 or reflected at the interface where the excitation light 30 first enters the lens portion 24 of the sensing element 22.

The sensing element 22, discussed above in connection with FIGURES 3, 6A and 5 6B, can be advantageously formed as a single piece, such as by injection molding of polystyrene. As shown in FIGURE 6A, the excitation light 30 entering the sensing element 22 first encounters the surface of the lens portion 124, which may be any of a number of suitable configurations such as a spherical or paraboloidal lens. The primary function of the lens portion 24 is to collimate signal recovery light 32, as shown in 10 FIGURE 6B. However, the lens portion 24 also plays a secondary role as regards the excitation light 30, essentially displacing the effective origin of the excitation light along the optical axis 45.

As described above in connection with the current state of the art, light provided by an excitation source is composed of an equilibrium distribution of ray propagation 15 angles and tapered fiber sections are oftentimes used to match numerical apertures to a level compatible with a sensing fiber when immersed in a fluid sample. However, this approach wastes significant input energy because the angular characteristics of most of the light rays are such that they contribute only weakly to the evanescent electric field strength. Other attempts use a taper along the full length of the sensing fiber, thereby 20 transforming low propagation angle rays at some point along the fiber to higher propagation angle rays that can contribute to the evanescent electric field. However, for these rays at lower angles to be productive, rays initially having larger propagation angles must necessarily have been lost. The continual upgrading of lower propagation angle rays by the fiber taper is obtained at the penalty of excitation light leakage along the fiber's 25 length. This means that assay sensitivity is variable along the fiber, which can cause calibration problems. Also, light leaking from the fiber into the exterior sample could lead to fluorescence excitation of the sample itself, instead of solely from bound fluorophore molecules.

Ideally, all incoming excitation rays should be very nearly at the critical angle of a 30 sensing fiber to maximize the evanescent electric field strength, thereby maximizing the fluorescence output by any fluorophore molecules bound to the fiber. Also, the sensing fiber should be of essentially constant diameter so that the sensitivity per unit length is constant, and with light leakage to the external environment minimized. As a practical

matter, a slightly tapered sensing fiber may be required as a consequence of manufacturing processes, such as fabrication by injection molding. Typically, a taper of approximately 0.02.degree. is sufficient to assure defect-free removal of a fiber from an injection mold, and such a taper has essentially negligible optical effects. Embodiments
5 of the present invention can provide a near-ideal situation, primarily due to characteristics of the reflector portion 26 of the sensing element 22.

Referring to FIGURE 6A, the reflective surface 27 of the reflector portion 26 is constructed with an axial profile such that all rays emitted from the end of the source fiber 38 are reflected at the same angle with respect to the optical axis 45 of the sensing
10 element 22. In other words, all rays in the sensing fiber 28 have the same propagation angle which is a highly desirable feature for an evanescent-wave-based sensor. Assuming the light source (i.e., the right-angle reflector 58 at the end of the source fiber 38) is approximately a point source, and that the angular distribution of the light emitted from that source falls within certain limits (discussed below), the shape of the requisite
15 reflecting surface 27 can be readily mathematically derived. In practice, the point source requirement is not a difficult condition to meet, since optical fibers are available with core diameters of as small as 3 .mu.m, and it is also possible to simply increase the relative size of the sensing element 22. As a practical matter, it has been found through experimentation that if the diameter of the sensing fiber 28 is about four times larger than
20 that of the source fiber 38, then the point source condition is approximately obtained.

The shape of the desired reflective surface 27 is defined by a rotation about the optical axis 45 of a curve 27A shown in FIGURE 8. With a point source of light assumed at an origin O, the curve 27A can be described in accordance with the depicted polar
25 coordinates as $r(\theta)$ where $r(\theta)$ is the distance from the origin O to the curve 27A, and θ is the angle between the excitation ray line 30 and the optical axis 45. The angle θ_0 is the desired constant exit angle relative to the optical axis, and $R(0)$ is the distance from the origin to the curve 27A at $\theta=0$ degrees.

Referring to FIGURE 9, it is apparent that the reflective surface 27 performs as desired only on rays within a certain range of propagation angles. As shown, those
30 excitation rays 30A propagating at a small angle relative to the optical axis 45 pass directly into the sensing fiber portion 28. Those rays 30B propagating at relatively large angles to the optical axis reflect off the reflective surface 27 a second time and are refracted out of the sensing element 22. However, even within these propagation angle

constraints, it is not difficult to collect and direct 80-90% of the rays into the sensing fiber portion 28 at the desired angle θ .

The numerical aperture for a polystyrene waveguide immersed in water is about 0.856. Light rays directed at larger propagation angles will leak into the surrounding water. The greatest evanescent electric field strengths will then be produced when the
5 excitation light propagation angle is very near the critical angle. The refractive index of polystyrene in the 600-700 nm waveband is about 1.584 leading to a critical angle of about 32.7.degree. relative to the optical axis. As a matter of practical design, however, it may well be better to use a lower propagation angle to compensate for effects of possible
10 misalignment associated with manufacturing tolerances, etc. A design propagation angle of approximately 2.degree. less than the critical angle is readily achieved and yields satisfactory results.

FIGURE 10 depicts the cumulative angular distribution of rays entering into the sensing fiber portion 28 of the sensing element 22, as modeled with a commercial ray-
15 tracing program, Opticad.TM.. The particular sensing element modeled is constructed with the dimensions shown in FIGURE 11, and with a 200 μm diameter source fiber 38 placed 0.5 mm distant from the facing surface of the lens portion 24 of the sensing element. For purposes of modeling simplicity, it is assumed that the source fiber 38 transports rays with a uniform distribution of ray angles up to a limiting numerical
20 aperture of 0.22.

FIGURE 11 depicts the specific geometries of the integrated lens portion 24 and the reflector portion 26, which may be described with reference to a lensmakers equation,

$$z(\text{mm})=7.59178h.\text{sup.2} -1.130917h.\text{sup.4} +15.184765h.\text{sup.6} -1.276721h.\text{sup.8} +3.500005h.\text{sup.10}$$
, which will be understood by those skilled in the art.

As shown in FIGURE 10, the fraction of rays at small propagation angles is quite
25 modest. Most rays are tightly clustered around the design propagation angle (expressed as a numerical aperture value of 0.81), and over 84% of the rays launched into the fiber portion 28 of the sensing element 22 have propagation angles expressed as numerical aperture values in excess of 0.75. Approximately 16% of the rays have propagation
30 angles expressed as numerical aperture values less than 0.15, representing those rays that passed through the aspherical reflector section 26 at a low propagation angle, and hence were not acted upon by the reflector 26.

A further improvement is provided by the central obscuration 56 used in the light source module 34 shown in FIGURE 4. Notably, FIGURE 10 does not include the effect of this obscuration 56, which would substantially block all of the lower propagation angle rays. Because the low propagation angle light does not materially contribute to the evanescent electric field strength, it is of little value for sensing signal generation. It can, however, be a significant source of non-signal background light that must be rejected by the interrogation module 40 (see FIGURE 6B). Such background flare light can come from several sources, such as fluorescence caused by a radiation of the bulk sensor material or trace impurities within it, or, alternatively, by excitation light leaking into the interrogation module 40 itself, or, alternatively, by excitation light that has been back-reflected from particles in the waveguide or from waveguide surface imperfections. Excitation rejection filters, such as the filter film 66 (see FIGURE 7A), cannot be made 100% efficient. By removing low propagation angle excitation light from the system, the amount of non-signal background light in the interrogation module 40 is correspondingly reduced with little effect on the evanescent electric field excitation of surface-bound fluorophores.

Referring to FIGURE 6B, it is desirable that signal recovery light 32 be collimated before it enters the interrogation module 40. The performance of the filter film 66 (see FIGURE 7A) typically deteriorates if rays impinge at angles more than about plus or minus 10.degree. from the design incidence angle. Since the fluorescence process generates an isotropic distribution of ray angles from any fluorophore site, it is also desirable to collimate the wide angular distribution of rays so that they can be directed to a small, low-noise photodetector.

The fraction of signal recovery light 32 that has comparatively low propagation angles exits the sensing fiber portion 28 and passes directly through the lens 24 of the sensing element 22. The surface of the lens portion 24 and its axial placement are such that these rays emerge from the sensing fiber 28 approximately at the focal point of the lens, thereby exiting from the lens in a collimated condition. However, a second and typically larger fraction of the signal recovery light 32 exits the sensing fiber portion 28 at large propagation angles. Many of these rays then advantageously strike the reflecting surface 27 of the reflector 26, which reflects this higher propagation angle light into the lens 24, and thereafter into the optical systems included within the interrogation module 40, thereby collecting a substantial portion of recovered signal light that would have

otherwise been lost. Ray modeling studies indicate that over 90% of the signal recovery light emitted from the sensing fiber 28 reaches the photodetector 64.

Any of numerous types of long-pass or band-pass filter designs may be employed for filter film 66, such as thin-film interference filters and optical crystals which can be made to transmit wavelengths above a critical wavelength and block wavelengths below that critical wavelength, or transmit within a waveband and reject over a second waveband. The simplest and most cost-effective filter film 66 may be a long-pass dichroic filter with specified filter characteristics that can be purchased from Optical Coating Laboratories of Santa Barbara, Calif. However, additional excitation blocking can be obtained in the exemplary waveband by using a spectrally-absorbing colored filter in combination with filter film 66, e.g., making plate 67 from a long-pass bulk filter material such as RG-645 or RG-665 sharp cut glass, manufactured by Schott Glass Technologies of Duryea, Pa; or R-62, R-64, R-66, or R-68 sharp-cut filter material from Hoya Corporation; or from an organic-dyed polymer filter material exhibiting strong absorbance at the laser wavelength and low absorbance over at least a part of the fluorescence emission waveband. As previously discussed, thin-film filters as a class are not effective at attenuating rays making steep angles to the optical axis 45, whereas colored filters are, thereby providing complementary function.

With solid state laser diode excitation sources 46 commercially available in the 600 to 700 nm waveband (e.g., 638, 645, 658 nm), excitation flare may be reduced by a factor of about 1000 to 10000 times using a long-pass filter combination that exhibits 50% transmission at a wavelength about 25 nm and longer beyond the laser's emission wavelength. When excitation blocking levels of this magnitude have been reached, residual flare light levels are strongly influenced by optical defects and material inhomogeneities and may have strong fluorescence and Raman components from the laser diode and other excitation optics components subjected to high light intensities. The signal-to-noise ratio may, at this point, be most effectively influenced by placement of a laser bandpass filter in light source 34 to prevent fluorescence emission, by changing the waveguide material and its purity, by improving the optical surface quality of sensing element 22, and by moving to excitation wavelengths that do not generate strong non-signal light levels in the optical interrogation module 40. For most dielectric materials, fluorescence and internal backscattering decrease rapidly as the operating waveband is moved to longer wavelengths. To detect small fluorescence signals above these

background effects, it may then be preferable to operate at the longest wavelength for which stable, high efficiency fluorophores are available.

One family of suitable molecules are the aluminum phthalocyanine compounds, disclosed in U.S. patent 5,494,793 to Schindele, et al., entitled "Monomeric
5 Phthalocyanine Reagents". A second family of suitable molecules are the Alexa Fluor dyes available from Molecular Probes, Eugene OR. A third family of suitable molecules are the CyDye cyanine dyes available from Amersham Pharmacia Biotech, Inc., Piscataway, NJ. FIGURE 12 shows the relative fluorescent signal strength per molecule as laser excitation wavelength is varied over the 600 nm to 700 nm waveband for four of
10 these red fluorescent labels developed for bioassays. For this comparison, a 30 nm spectral gap between the laser and blocking filter was used. Laser diodes are commercially available at the following wavelengths from various manufacturers; 633 nm, 635 nm, 640 nm, 650 nm, 655nm, 670nm, 675nm, 680nm, 685nm, and 690nm. Other wavelengths may of course become available in the future and manufacturers can custom-
15 select from production to provide wavelengths that are not at the published output wavelength. In addition, a light emitting diode excitation source may be used with suitable filtering such as a thin-film filter, to more tightly define and restrict the maximum emission wavelength.

With this understood, to obtain the best signal-to-noise ratio in a fluorescence-
20 based evanescent-wave sensing system using inexpensive off-the-shelf excitation sources, it can be concluded from FIGURE 12 that excitation wavelengths beyond 660 nm are of less interest because of their poor signal strengths and that an excitation wavelength of about 640nm to 650 nm provides a very good match to several available fluorophores, and there are fortunately many sources available in this range.

25 The light that passes through the interrogation module window 60 and which has been filtered of excitation light is focused by a short focal length lens onto a suitable low-noise photodetector 64. Any lens of high light-gathering power may be used, with a particularly effective and compact design being created by a sapphire or high-index glass sphere of 1 to 10 mm diameter. Sapphire spheres of optical quality may be purchased
30 from Edmund Scientific of Barrington, N.J. A solid-state photodiode is a suitable photodetector 64, since it is small, consumes no power, and has low noise. Light falling on the photodetector 64 is then converted to a photocurrent, which in turn is converted to a voltage using standard small-signal electronic amplification methods, such as

synchronous detection. Using a 6 mm sapphire ball lens; a low-noise photodiode, type S4707-01 from Hamamatsu, Inc. of Bridgewater, N.J.; and a synchronous detection amplification technique operating at an optimum chopping frequency of 135 Hz; an extremely favorable photocurrent sensitivity of 0.025 pA was realized.

5 Although much of the discussion above focuses on applications to evanescent-wave-based sensors, those skilled in the art will appreciate that the sensing element 22 may be suitably adapted for use in a surface plasmon resonance sensor. The ability to convert various propagation angles of light into an approximately constant propagation angle for transmission into a optical fiber is particularly advantageous for surface
10 plasmon resonance techniques. As described above, in connection with the current state of the art, the detected resonance spectrum for currently available surface plasmon resonance sensors is the superposition of resonance spectra associated with light at various propagation angles transmitted down the sensing fiber. If, instead, light of essentially a single propagation angle is used, the resonance effect in the transmitted
15 spectrum is much better defined, is more easily detected, and affords better quantitative analysis.

 The assay system described above is readily adapted for use with surface plasmon resonance sensing operations. A light source module producing white light can be coupled to the sensing element 22 by a source fiber, an interrogation module, and an
20 interrogation window, of substantially similar configuration to the above-described source fiber 38, interrogation module 40, and interrogation module window 60. If the surface plasmon resonance sensor fiber 114 includes a mirror 122 for returning signal light (see FIGURE 1B), then an optical system much like that of the interrogation module 40 can be employed. Of course, a spectral grating and array detector (or other suitable
25 spectrophometric devices) would be substituted for the photodetector 64 (see FIGURE 6B.), and the filter 66 (see FIGURE 7A) would be omitted from the design.

 Removal of low propagation angle light, as in the use of the obscuration 56 of FIGURE 4, provides a number of advantages to surface plasmon resonance sensing operations. Low propagation angle light does not stimulate surface plasmon waves,
30 except in metal films too thin to readily fabricate by currently available methods. In the case of back-reflected signal light from the mirror 122 of FIGURE 1B, low propagation angle light is essentially signal noise which partly obscures the resonance effect to be

measured. The reflector portion 26 of the sensing element 22 also advantageously adjusts lower propagation angle light to higher propagation angles.

In accordance with ready adaptations of the embodiments described above, high numerical aperture light of approximately a constant propagation angle can be provided to a surface plasmon wave sensor. FIGURE 13 shows the results of modeling a surface plasmon resonance sensor employing the optical features of the sensing element 22, as compared to the current state of the art (shown both in FIGURES 2B and 13). Assumed values include a silica optical fiber core of 400 microns having a 55 nm thick layer of gold, and a propagation angle of light of 21.60 degrees, relative to the optical axis of the fiber core, having a uniform dispersion of +0.2 degree. The difference between the two curves illustrates the significant improvement afforded to surface plasmon resonance techniques by adaptation of the assay system described above.

FIGURE 14 depicts a disposable injection molded assay card 80 which may incorporate four sensing elements 22. The four axially-interrogated sensing elements 22b may include a tab 82, which is preferably of integral, one-piece construction with the lens 24, reflector 26, and sensing fiber 28. The tab 82 assists in manipulation and placement of the sensing element 22 into a molded-in flow channel 88 in the coupon 80. In this embodiment, excitation and signal recovery are provided by four optical interrogation modules 40. The coupon 80 includes a cover 84 for sealing the molded-in flow channel 88 and a multi-needle septum 90 for introducing sample and reagent fluids into the card. The fluids may be distributed separately to each channel 88 and its axially-located sensing element 22, or the channels 88 may be joined together head-to-tail to form a single serpentine flow channel. It may be preferable to isolate the individual waveguides, at least insofar as the reagents are concerned so as to prevent cross-reactions between reagents and to allow reagent concentrations and reaction rates to be maximized. Alternatively, the card may have only one fluid chamber in which a plurality of parallel-mounted waveguides 28 are mounted.

At the time of use, the card 80 is inserted into an assay unit (FIGURE 15) in which other ancillary components of the selected assay system are included, such as multichannel peristaltic pumps for fluid control and on-board reservoirs for buffer, reagent, and waste fluids, as will be understood by those skilled in the art.

ROBOTIC OPERATION

The sensing element 22 is ideally suited for use in an immersion-type assay protocol, either alone or as one element of an array of evanescent-wave probes. An immersion protocol is defined as a procedure wherein an elongate rigid sensor, such as a cylindrical waveguide, is physically immersed in one or more liquids, at least one of which contains the target substance. Optionally, the protocol may involve immersion of the waveguide in one or more additional fluids; for cleaning purposes; to create luminescence; to create or modify fluorescence in the evanescent region of the waveguide; or to modify transported optical power in the waveguide.

Many assay systems and protocols use disposable modules analogous to assay card 80 where about 1 cc or less of fluid is introduced into a fluidic structure that includes the sensing element array. An immersion protocol, however, has advantages in food safety, environmental and medical applications where the target pathogen concentration is very low or the sample is heterogenous, viscous or contains components that may foul assay apparatus. Examples of such substances include whole blood, liquefied stool samples, sewage, milk, and homogenized meat and sausage. In these cases, available sample volumes may be quite large while the acceptable pathogen level may be very low. In this situation it may be desirable to use an immersion-type assay on a large sample volume and provide means for the detector to execute a sampling pattern within the volume to improve sampling statistics. This may also better control or prevent the spread of contaminated media into complex and expensive assay fluidics that might otherwise be necessary.

Of particular interest for the detection of human pathogens in food, water and the environment is the sandwich format fluoroimmunoassay. In a typical waveguide-based sandwich immunoassay, the waveguide has a monolayer of a biological recognition element, such as capture antibody 100 immobilized on its surface as shown in FIGURE 1A. The biological recognition element may be bound to the sensor 22 by a number of techniques known to those skilled in the art. In the particular case wherein sensor 22 is constructed of polystyrene and the biological recognition element is an antibody, simple physical adsorption of the antibody to the surface of the sensor provides a robust and stable means of attachment. Such monolayer-coated waveguides may maintain antibody activity for a period of months if not subjected to high temperature.

At the time of use, the waveguide is first incubated with the fluid sample that may contain the target antigen for about 1 to 5 minutes. After a wash step, the waveguide is incubated in contact with a fluorophore-labeled antibody for 1 to 5 minutes to form an antibody/antigen/labeled-antibody sandwich that will fluoresce when excitation light is passed through the waveguide.

One embodiment of an automated apparatus 500 for performing sandwich format immunoassays is shown in FIGURE 16. Apparatus 500 consists of a robotic arm 501 and an optics module 502, both under the control of embedded microcontroller 44. Robotic arm 501 provides one- or two-dimensional movement in a horizontal plane to transport a waveguide 28 array to processing stations where various liquids used in the assay are stored, and vertical motion to immerse and remove a waveguide 28 array from liquid. Optics module 502 may contain one or more sets of interrogation optics consisting of light source 34 and optical interrogation module 40. By way of nonlimiting example, there may be six separate sets of interrogation optics mounted at 60 degree intervals in a circular pattern of about 1 cm to 10 cm diameter in optics module 502. The six disposable optical sensing elements 22 in this example are shown mounted on a disposable carrier plate 503 using sonic or adhesive bonding methods in FIGURE 17. The carrier plate 503 is preferably colored black and may be of a polymer material such as polystyrene, PMMA, polyvinylchloride, ABS, polycarbonate or the like, and may be from 0.5 to 2.0 mm thick and about 50 mm in diameter. Alternatively, the carrier plate 503 and sensing element 22 array may be injection molded as a one-piece transparent part. When plate 503 is mounted to the underside of optics module 502, the optical axis 45 of each sensing element 22 is coaxial with the corresponding optical interrogation module 40.

An assay-performing apparatus 500 for performing sandwich format fluoroimmunoassays may include an assay module 504 below the robotic arm 501 that provides three stations for performing individual assay steps; a sample station 505 for sample incubation; a washing station 506 for waveguide 28 washing, and a reagent station 507 for incubation of the waveguide 28 in a solution of fluorophore-labeled antibody reagent. To perform an assay, the robotic arm 501 first moves the waveguide 28 array to sample station 506 and immerses the array (each element of which has been coated with a capture antibody by one skilled in the art) into a disposable cup 513 of about 1 to 500cc which has been filled with the fluid sample 510 to be examined. The array is incubated in the sample fluid 510 for a predetermined time. During this time,

each waveguide 28 may be moved through a predetermined pattern by the robotic arm 501 (or by a manner to be described at a later point), so as to contact the sample volume in a statistically valid manner. Since there may be only one target material of interest, the six waveguides in this example may be coated with the same capture antibody and it is
5 apparent that a multiwell cup holder could be provided (not shown) to increase sample throughput. Six appropriately-sized and shaped pockets would be provided in such a cup holder for six different fluid samples 510.

Referring again to FIGURE 16, upon completion of this incubation step, robotic arm 501 moves the waveguide 28 array to washing station 506 and immerses the array in
10 washing fluid 511, which may be phosphate-buffered saline with 0.1% surfactant, contained in a disposable cup 514 or in an open reservoir (not shown) that may be periodically flushed using a fluid circuit controlled by embedded microcontroller 44. Any residues of sample fluid 510 are cleaned off in this step by rapidly moving the array in a horizontal oscillatory pattern. Antigen/antibody reactions are typically sufficiently strong
15 that this physical motion will not remove target material, but will wash off nonspecifically bound sample and reagent materials that may otherwise adversely affect assay results. At the end of this step and before removal from washing fluid 511, each waveguide 28 is interrogated with excitation light and a signal baseline is established.

Upon completion of this baseline measurement, robotic arm 501 moves the
20 waveguide 28 array to a reagent station 507. Located at this station are a set of six nominally 0.1 to 5 cc disposable vials 515 which contain fluorophore-labeled antibody solutions 512a through 512f (FIGURE 18), each vial having an axis that corresponds to a waveguide axis in the waveguide 28 array, and which may be maintained at a constant temperature through means such as a thermoelectric heating/cooling apparatus, or phase
25 change material. Since the waveguides in waveguide 28 array may be coated with antibodies that are specific for different target materials, the vials 512a through 512f may each contain a different antibody reagent.

During a predetermined incubation period, the waveguide 28 array is periodically or continuously interrogated to monitor fluorescence signal levels. After incubation is
30 completed, the robotic arm 501 may move the waveguide 28 array to the wash station 506, and immerse and wash the waveguides with oscillatory motion to remove any antibody reagent residues. Signal levels may be measured again at this point.

This protocol provides at least three methods for determining target material concentration. Target concentration may be monotonically related to signal rate-of-change immediately after immersion in the fluorophore-labeled reagent vials; to the change in signal level experienced during fluorophore-labeled reagent incubation; and to
5 the change in baseline signal level as measured in the wash fluid 509, before and after fluorophore-labeled reagent incubation. The first method provides an early response, the second method may provide increased accuracy, while the third technique requires more time but allows sensitive measurements to be made even when the fluorophore-labeled reagent is strongly fluorescent.

10 Three-step luminescent and fluorescent assays performed on assay platform 500 are well-suited for measuring trace constituents in difficult samples such as whole blood, liquefied stool samples, sewage, milk, and homogenized meat and food products, since most contaminants are flushed off the waveguide 28 before it is immersed in the light- or fluorescence-producing reagent, allowing high sensitivity measurements to be made with
15 minimal sample preparation. Only the distal portion of a small diameter waveguide 28 actually contacts the potentially contaminated samples, and fluids are stored in disposable cups or vials, resulting in a system that is easily maintained and used.

Extraneous room light may adversely affect low-level optical signal measurements and to prevent this from occurring, a noncontacting light-excluding
20 labyrinth seal 520 may be used between assay module 504 and optics module 502, as shown in FIGURE 19. This seal uses a series of interlaced but noncontacting annular ring walls 521 projected from both parts and separated radially by a distance at least equal to the oscillatory washing cycle length described above. External light interference is minimized when the axial separation between the interpenetrating walls is minimized,
25 or when the annular pockets on assay module 504 are maximally deep. The latter is optically preferred but may make module 504 more difficult to clean. By way of nonlimiting example, for an array consisting of equally-spaced optical sensing elements 22 on a 4.6 cm circle, room light is excluded by labyrinth seal 520 if the annular walls 521 are 1.5 mm thick, 1 cm in axial length, and separated radially by 1 cm and axially by
30 1.0 mm. Other methods for minimizing external light interference while allowing lateral movement of optics module 502 relative to assay module 504 during incubation and washing include black elastomer bellows; external light shields; and synchronous signal

detection. The latter electronic method can assist in nulling background light but is not preferred as a single solution at the low signal levels associated with evanescent assays.

The geometric characteristics of optical sensing element 22 are optimal for immersion assays. There is a linear relationship between signal strength and waveguide
5 28 immersion depth, but no corresponding relationship between signal strength and the amount of waveguide 28 protruding above the sample fluid 508 surface. This means that the interface between the optical sensing element 22 and optical interrogation module 40 can be remote from fluid contact, allowing that interface to be kept optically clean. However, an extremely long waveguide is not desirable as it may impact on mass transfer
10 enhancement methods by making the waveguide too flexible.

A distinct advantage of the waveguide-based immersion assay method is that significant transverse fluid velocities can be generated. It is well-known to those skilled in heat and mass transfer that very high heat and mass transfer rates are possible when heat or mass is being transferred to a small-diameter cylinder or ellipse in cross-flow.
15 This is attributable to a greatly reduced mass transfer boundary layer thickness in cross-flow due to short fluid element residence times. This means the target species can penetrate closer to the object's surface and, when applied to a bioassay, will have a higher probability of reacting with constituents such as capture antibodies in the evanescent layer. By contrast, it is very difficult to enhance mass transfer in a coaxial flow geometry
20 such as in assay card 80 because flow is typically laminar and a thick mass transfer boundary layer builds up at the waveguide 28 surface because of the parallel flow geometry and long fluid contact time.

One method for mass transfer enhancement with assay-performing apparatus 500 has been previously described, namely oscillatory lateral movement of waveguide 28. A
25 second method particularly suited to large homogenized food samples is to modify sample station 505 to provide rotary motion of sample cup 513. FIGURE 20 shows in sectional view a sample cup 513 on such a motorized stage 530. The station includes a motorized drive 531, under control of embedded microcontroller 44, and turntable 532 upon which sample cup 513 is placed. The waveguide 28 array is positioned coaxial to
30 sample cup 513, with individual elements adjacent to and equally spaced from the cup perimeter, where fluid velocities are a maximum. Since the waveguide 28 array is disposed in a symmetric circular pattern, each array element experiences the same fluid movement and by rotating the cup clockwise and counterclockwise for equal time

periods, each side of waveguide 28 is uniformly subjected to the effects of flow. At very low velocities, flow enhancement may come primarily from bulk fluid movement. At higher velocities the array elements will begin to shed vortices which augment sample mixing. The sample cup 513 may also be molded with built-in vanes and features which serve to circulate and mix sample throughout the volume, or a mechanical stirring means, such as magnetic stir bar, may be added to facilitate sample circulation.

Rotational rates and mass transfer enhancement may be limited to a perimeter velocity of about 25 cm/sec for simple cups. At that perimeter velocity a water-based sample fluid 510 will climb up the cup wall about 0.25 cm, and may spill over the cup's edge. Considerably higher perimeter velocities can be reached with the annular cup 540 shown in FIGURE 21 without danger of spilling. In the absence of surface tension effects, the climb height h is given by

$$h = (2\pi^2 F^2)(R_1^2 - R_0^2)/g$$

Where f is the rotational rate and R_0 and R_1 are the inner and outer radii of the annular space, respectively. As a nonlimiting example, if the outer radius is 2.35 cm and the inner radius is 1.85 cm, then for a maximum tolerable climb height of 2.5 mm, the calculated maximum permissible velocity increases by a factor of 1.7 times. An experimental test under these conditions yielded a higher velocity enhancement, of 2.0 times. This was due in part to a surface tension-related leveling that occurs with small gaps, a beneficial effect which is not included in the previous equation.

It will be appreciated that, although embodiments of the invention have been described for purposes of illustration, various modifications may be made without deviating from the spirit and scope of the invention. For example, FIGURE 22 depicts a multi-element sensor 130 having a plurality of approximately parallel sensing elements 132 formed as a single unit in combination with a single cylindrical lens portion 134. The cylindrical lens portion 134 is functionally substituted for the lens portion 24 described above; a cylindrical lens 136 is functionally substituted for the sapphire ball lens 62; and, an array of photodiodes or a linear charge-coupled device 138 is functionally substituted for the photodetector 64. The sensing elements 132 each include a slab waveguide portion 140 and two-dimensional reflector portion 142, with reflecting side surfaces defined mathematically like the reflective surface 27 described above. Advantages of the multi-element sensor 130 may include improved manufacturability, more flexible design

parameters, improved waveguide power densities, and greater sensing surface area to test sample volume, thereby improving signal to noise characteristics.

As another example, any of a variety of lens configurations can be functionally substituted for the GRIN lens 52 described in connection with FIGURE 4. Blocking low propagation angle light can be readily accomplished by a compound lens configuration, including paired planoconcave lenses forming highly collimated light, in which an obscuration is selectively positioned.

Particular optical structures, such as optical fibers, refractive surfaces and reflective surfaces have been described in connection with certain embodiments of the present invention. However, those skilled in the art will appreciate any number of light-directing media and devices which can be suitably adapted and combined to achieve the above-described effects and functions. For example, any of a wide variety of waveguides may be adapted for use as sensing elements. Also, metallized mirror reflecting surfaces may be substituted for the described dielectric surfaces. Reflective surfaces may be substituted for refractive surfaces, and vice versa.

The above-described embodiment of the reflector 26, whether alone or in combination with the lens 24, functions essentially as a light redirection device, which adjusts or otherwise modifies the propagation angle of light. The above-described embodiment of the light source module 34 includes, by virtue of features associated with the described lens 52 and obscuration 56, a light selection functionality in which certain ranges of light propagation angles may be blocked, passed, or otherwise selected for provision to subsequent light processing components. The above-described embodiments of the source fiber 38 and, in part, the sensing fiber 28 function as light transfer devices. Those skilled in the art will appreciate that a wide variety of alternative media, elements, and devices can be functionally substituted for these particular described embodiments.

Those skilled in the art will appreciate that various embodiments of the invention may be applied in fields other than assay methods and apparatus. Additionally, distinguishing between components such as a light source module and sensing element is somewhat arbitrary, since certain of the features described in connection with the sensing element could be suitably adapted to form a part of a light source module. Further, although the description above identifies "optical" features and effects, the invention encompasses any of a wide variety of equivalent features and effects associated with other parts of the electromagnetic spectrum, including light other than visible light.

These and other variations can be made to the invention in light of the detailed description above. In general, in the following claims, the terms used should not be construed to limit the invention to the specific embodiments disclosed in the specification, but should be construed to include all energy-directing media and devices
5 that operate under the claims to provide associated signal transfer, retention, and detection characteristics. Accordingly, the invention is not limited by the disclosure, but instead its scope is to be determined entirely by the following claims.

While the preferred embodiment of the invention has been illustrated and described, it will be appreciated that various changes can be made therein without
10 departing from the spirit and scope of the invention.

The embodiments of the invention in which an exclusive property or privilege is claimed are defined as follows:

1. An optical assay apparatus for detecting analytes in a sample, the apparatus comprising:

(a) a light source module operable to produce light rays directed at a range of angles relative to the assay apparatus, wherein the light source module comprises a light source operating at a wavelength from greater than about 635 nm to about 700 nm;

(b) an optical sensor optically coupled with the light source module and including a ray redirection portion and an assay sensing portion, the ray redirection portion operable to receive the light rays produced by the light source module and to correspondingly provide light rays directed at an approximately constant angle to the assay sensing portion, the assay sensing portion comprising a waveguide having a cylindrical or elliptical cross-section, wherein the waveguide has a sensor chemistry coating, the light of the substantially constant propagation angle passing through the waveguide and creating an evanescent electric field in the sensor chemistry coating, the assay sensing portion collecting light emitted from the sensor chemistry coating in response thereto; and

(c) an interrogation module optically coupled with the optical sensor and operable to receive the collected light emitted from the sensor chemistry coating, the interrogation module comprising:

(i) a photodetector; and

(ii) a filter located in the interrogation module between the photodetector and the optical sensor, the filter being selected so as to block greater than about 99.9 percent of radiation at the light source wavelength and to have greater than about 50 percent transmission at wavelengths greater than the wavelength that is about 25 nm longer than the light source output wavelength, to thereby maximize recovery of the collected light emitted from the sensor chemistry coating.

2. The apparatus of Claim 1, wherein the light source operates at a wavelength in the range from about 638 nm to about 650 nm.

3. The apparatus of Claim 1, wherein the light source excites a fluorophore in the sensor chemistry coating having an absorbance in the range from greater than about 635 nm to 700 nm.

4. The apparatus of Claim 3, wherein the fluorophore is at least one of CY5, Alexa Fluor 660, Alexa Fluor 680, and an aluminum phthalocyanine.

5. The apparatus of Claim 3, wherein the fluorophore emits at a wavelength in the range from greater than about 635 nm to about 800 nm.

6. The apparatus of Claim 3, wherein the light source excites a fluorophore at a wavelength selected to produce maximum signal per fluorophore molecule.

7. The apparatus of Claim 1, wherein the filter is at least one of a laser line-rejection filter film, a long pass dichroic filter film, a spectrally-absorbing bulk filter, a colored glass bulk filter, a colored polymer bulk filter, or a combination of a filter film and bulk filter to provide a long pass filter.

8. An automated system for performing an assay using an immersion protocol, comprising:

a robotic stage;

one or more light source modules operable to produce light having a range of propagation angles;

one or more sensors mounted on the robotic stage and being optically coupled with the one or more light source modules to receive light produced by the one or more light source modules, each sensor including a light adjusting portion and an assay sensing portion, the light adjusting portion receiving the light produced by the one or more light source modules and providing light of a substantially constant propagation angle to the corresponding assay sensing portion, the assay sensing portion comprising a waveguide having a cylindrical or elliptical cross-section, wherein the waveguide has a sensor chemistry coating, the light of the substantially constant propagation angle passing through the waveguide and creating an evanescent electric field in the sensor chemistry coating, the assay sensing portion collecting light emitted from the sensor chemistry coating in response thereto;

one or more interrogation modules configured to be optically coupled with the one or more sensors and operable to receive the collected light emitted from the sensor chemistry coating; and

a plurality of containers each containing a fluid;

wherein the robotic stage is configured to move the one or more sensors from one container to another, thereby eliminating the need to transfer fluids while an assay is being performed.

9. The system of Claim 8, wherein the assay is a fluoroimmunoassay.

10. The system of Claim 8, wherein the stage comprises a two-axis or three-axis moving stage.

11. The system of Claim 8, wherein reaction rates between the sensor chemistry coating on the waveguide and reactants in solution in one of the plurality of containers are increased by creating relative motion between the waveguide and the surrounding solution to minimize mass transfer boundary layer thickness.

12. The system of Claim 11, wherein the mass transfer boundary layer thickness is reduced by oscillating the waveguide in the solution in a direction perpendicular to the long axis of the waveguide.

13. The system of Claim 11, wherein the mass transfer boundary layer thickness is reduced by rotating the solution within one of the plurality of containers to provide flow of the solution perpendicular to the long axis of the waveguide.

14. The system of Claim 8, wherein sampling statistics and assay sensitivity are increased for dilute analytes by exposing the waveguide to a large volume of sample solution in one of the containers.

15. The system of Claim 14, wherein the container including the sample solution comprises a cup rotated by an external drive to rotate the solution therein past the waveguide.

16. The system of Claim 14, wherein the sample solution is mixed and circulated by an internal stirrer.

17. The system of Claim 8, wherein a plurality of sensors are provided and are radially symmetrically arranged.

18. The system of Claim 8, wherein a plurality of sensors are provided and are linearly arranged.

19. The system of Claim 8, wherein the one or more sensors are mounted on a carrier plate, which in turn is mounted on the robotic stage.

20. The system of Claim 19, wherein the one or more sensors and the carrier plate comprise an integral molded part.

21. The system of Claim 8, wherein at least one of the plurality of containers comprises one or more baffles for forming a light-tight seal.

22. The system of Claim 8, wherein a plurality of sensors are provided, and one interrogation module is configured to be optically coupled with each of the plurality of sensors to receive the collected light emitted from the sensor chemistry coating on each of the corresponding waveguides.

23. The system of Claim 8, wherein a plurality of sensors and a plurality of interrogation modules are provided, each of the plurality of interrogation modules being configured to be optically coupled with each of the plurality of sensors, respectively.

24. A method for analyzing a sample for an agent using an immersion assay protocol, the method comprising the steps of:

- (a) providing an optical assay apparatus, the apparatus comprising:
 - (i) a light source module operable to produce light having a range of propagation angles, and
 - (ii) a sensor operable to receive light produced by the light source module, the sensor including a light adjusting portion and an assay sensing portion, the light adjusting portion receiving the light produced by the light source

module and providing light of a substantially constant propagation angle to the assay sensing portion, the assay sensing portion comprising a waveguide having a cylindrical or elliptical cross-section, wherein the waveguide has a sensor chemistry coating, the light of the substantially constant propagation angle passing through the waveguide and creating an evanescent electric field in the sensor chemistry coating, the assay sensing portion collecting light emitted from the sensor chemistry coating in response thereto; and

(b) moving the optical assay apparatus from a first fluid to a second fluid, thereby eliminating the need to transfer fluids while an assay is being performed.

25. The method of Claim 24, wherein the agent is a human pathogen.

26. The method of Claim 24, wherein the sample is a food sample.

27. The method of Claim 24, wherein the step of moving the optical assay apparatus is performed automatically.

28. The method of Claim 24, wherein the optical assay apparatus is moved two dimensionally or three dimensionally.

29. The method of Claim 24, wherein the first fluid comprises a sample solution and the second fluid comprises a fluorophore-labeled reagent solution.

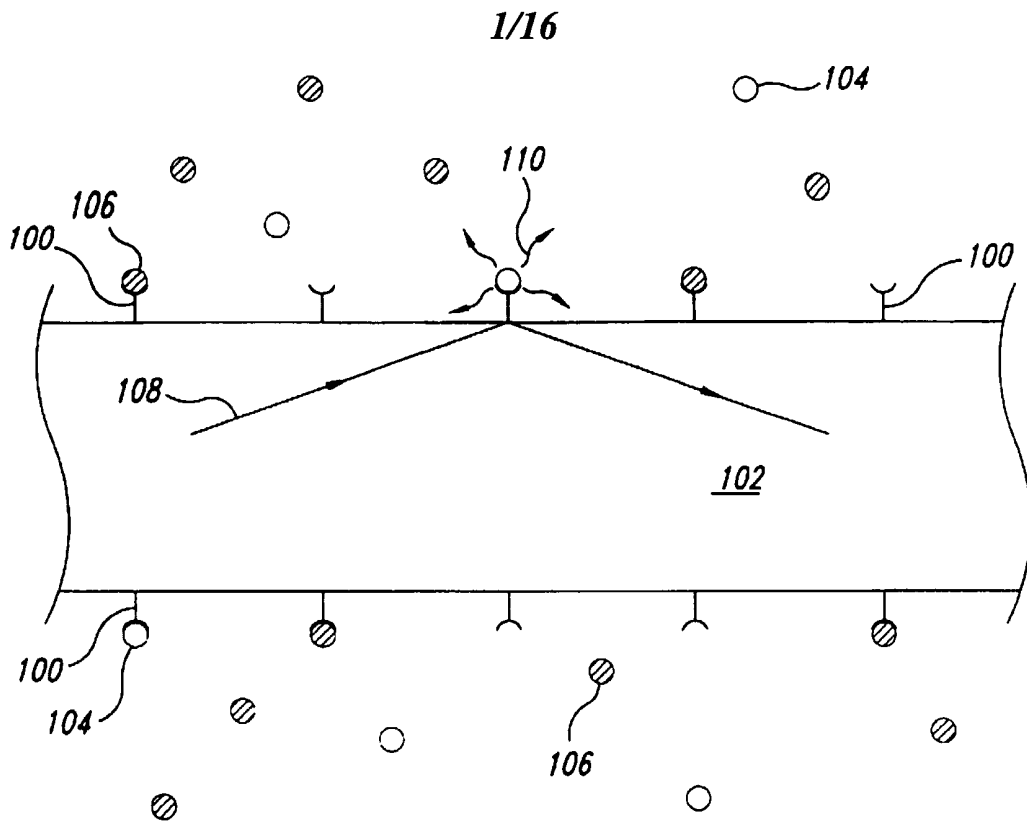

Fig. 1A
(PRIOR ART)

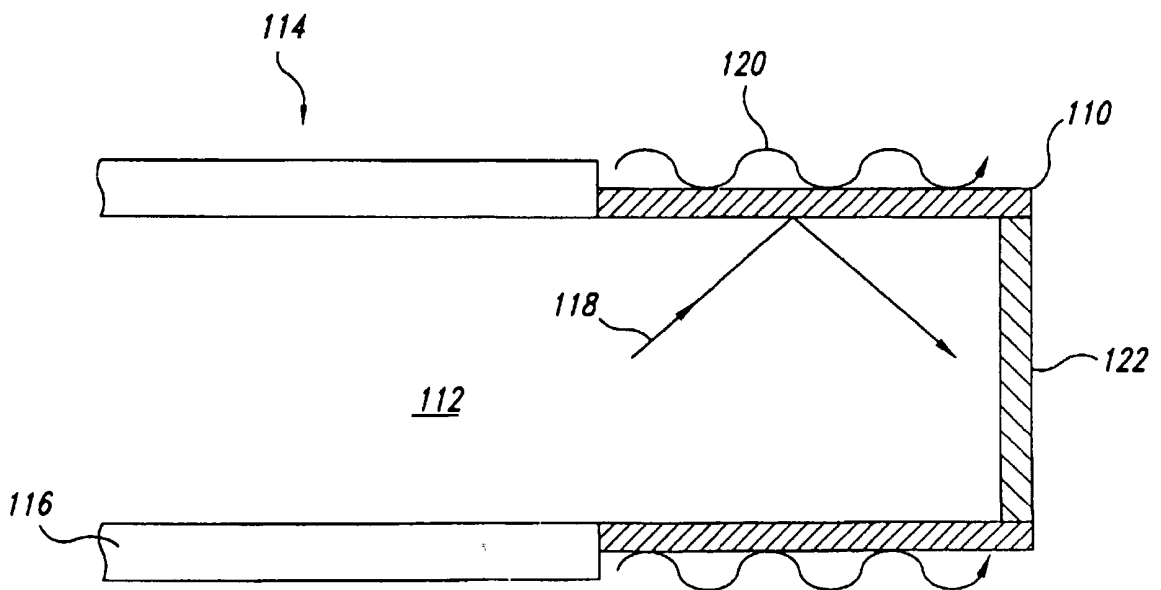

Fig. 1B
(PRIOR ART)

2/16

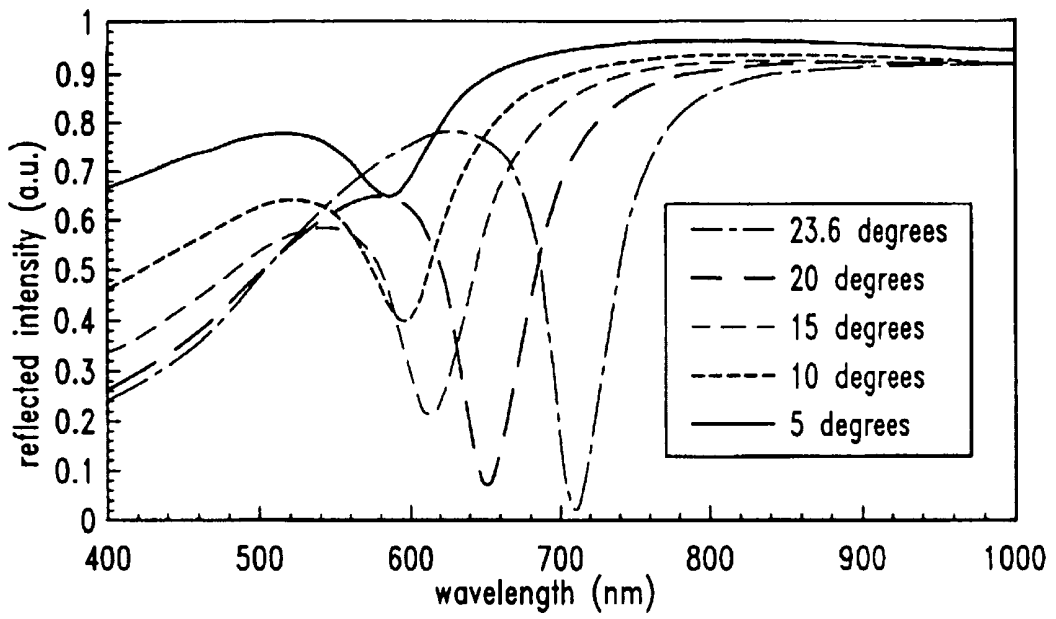

Fig. 2A
(PRIOR ART)

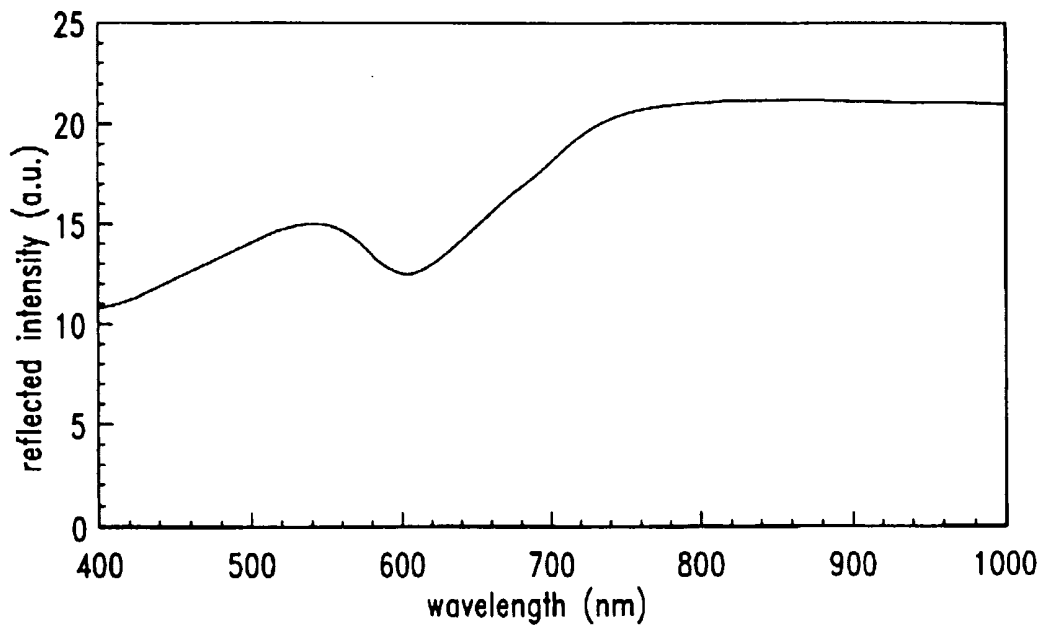

Fig. 2B
(PRIOR ART)

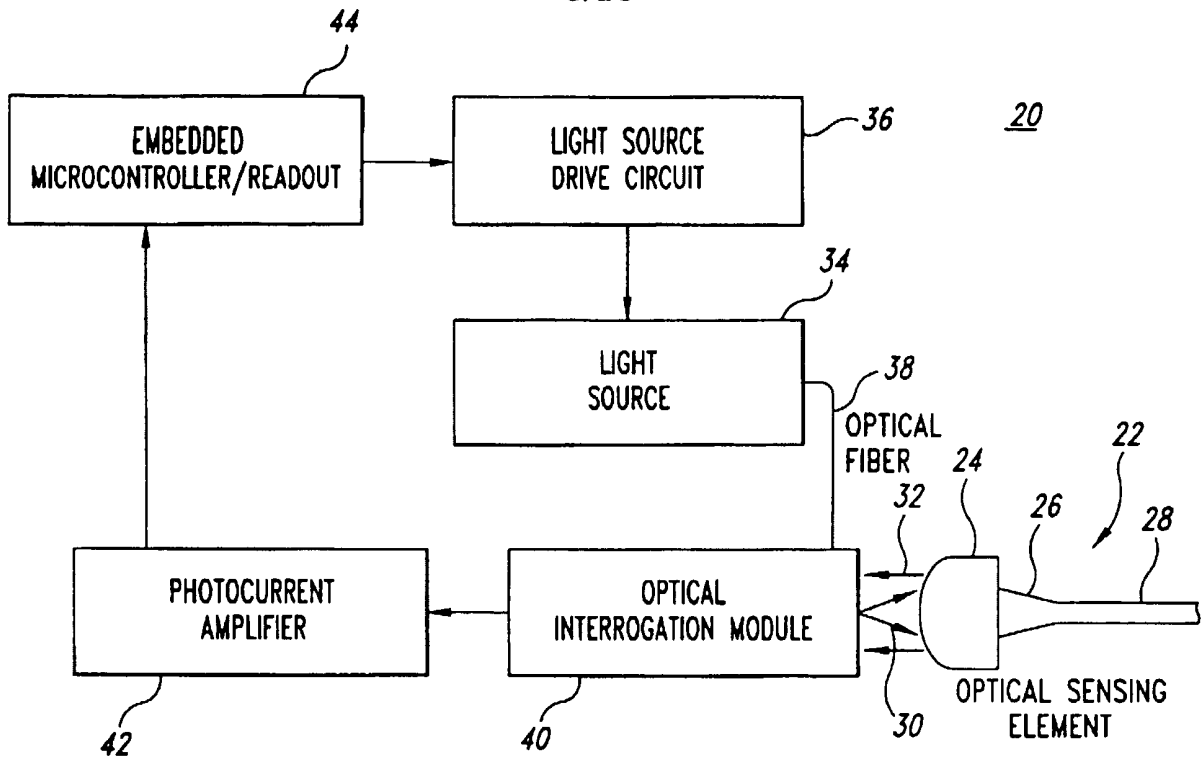

Fig. 3

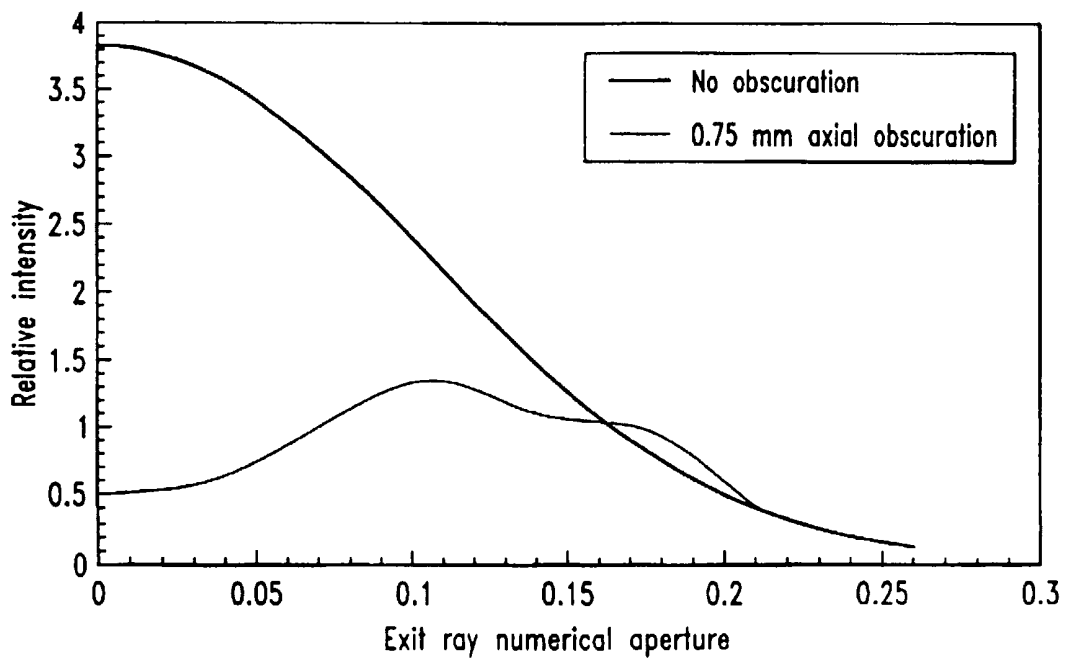

Fig. 5

34

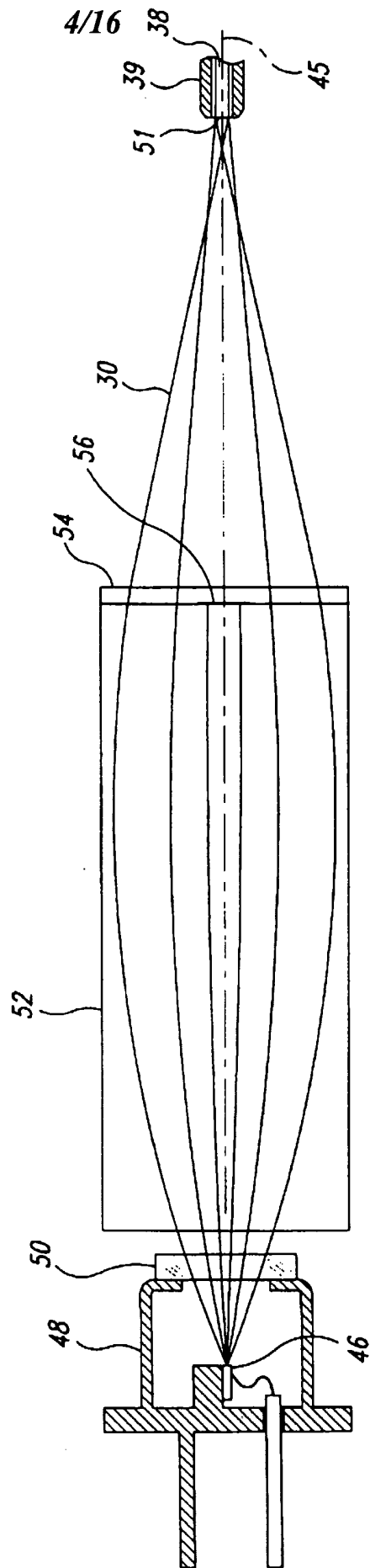

Fig. 4

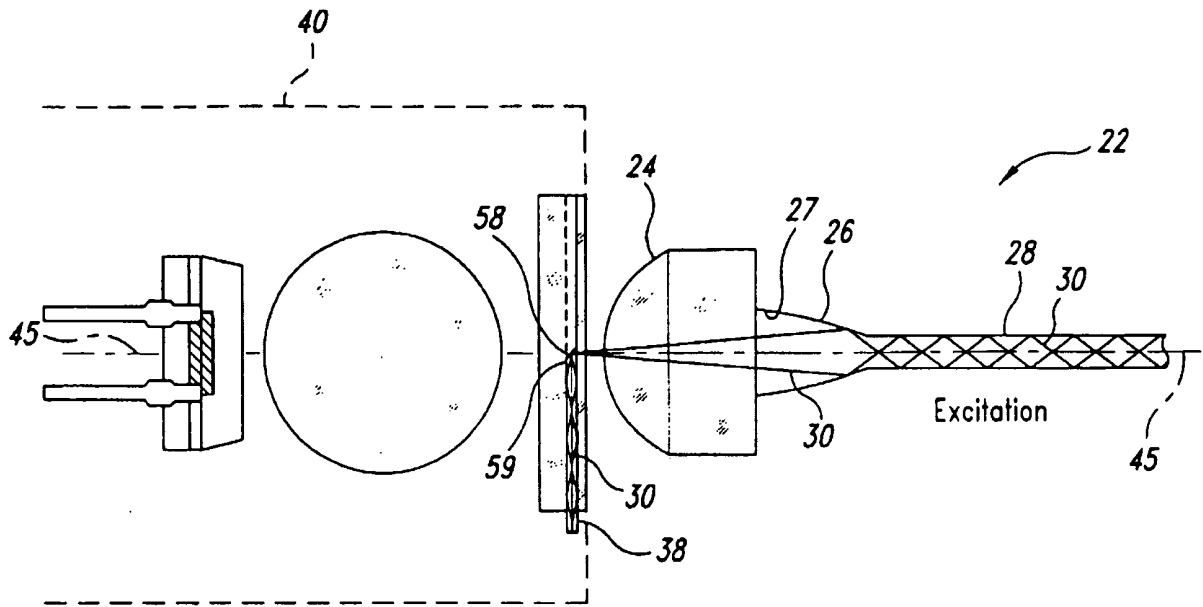

Fig. 6A

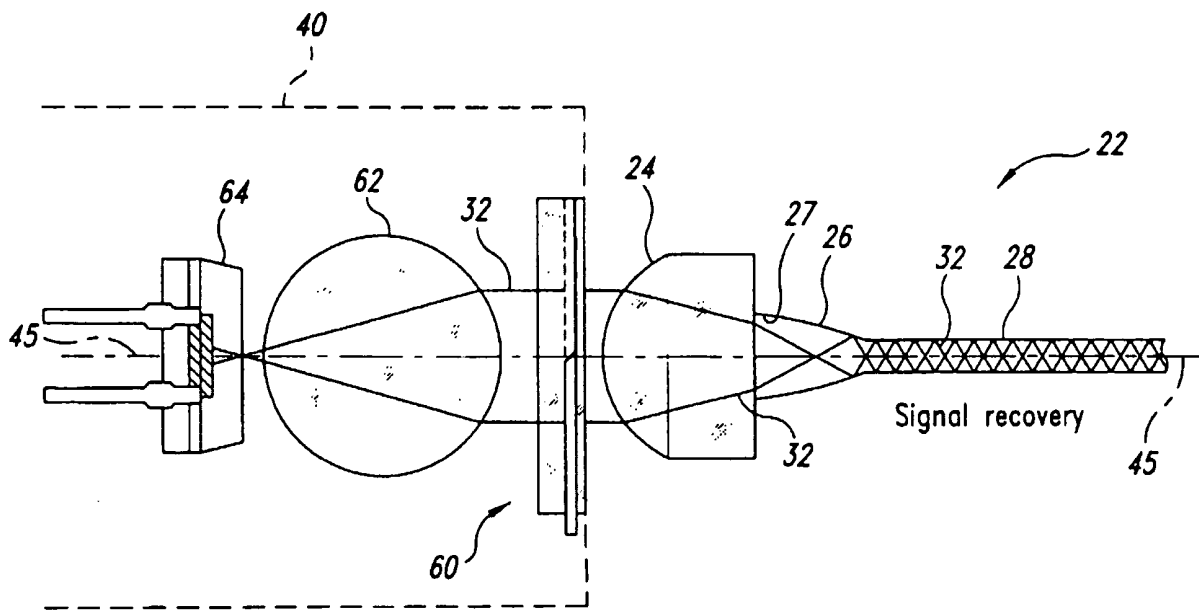
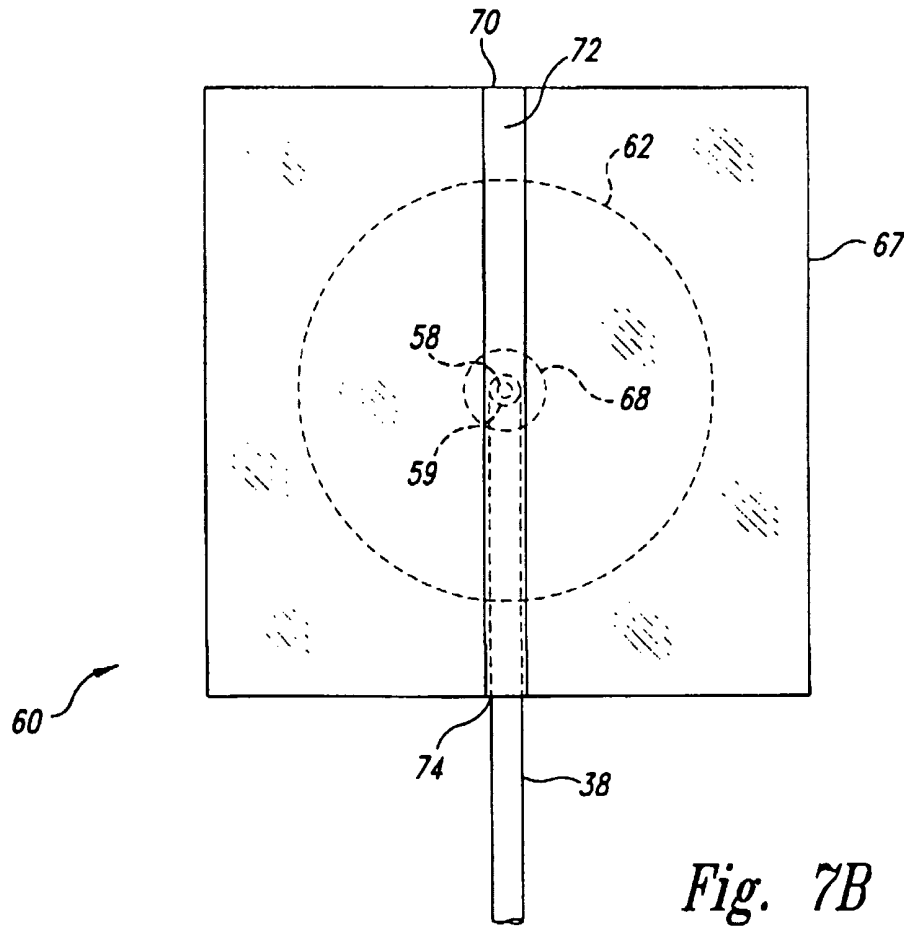
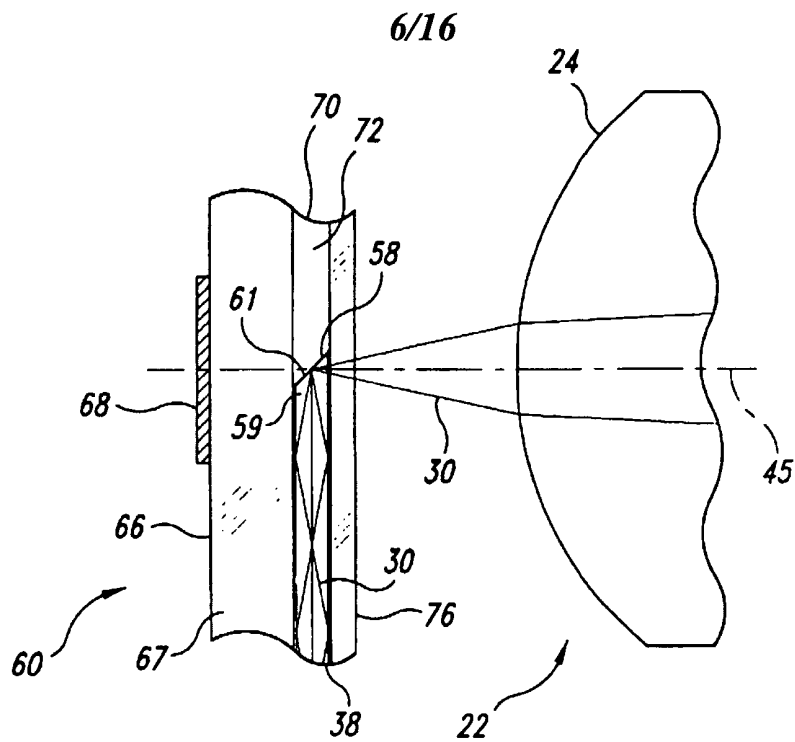

Fig. 6B



7/16

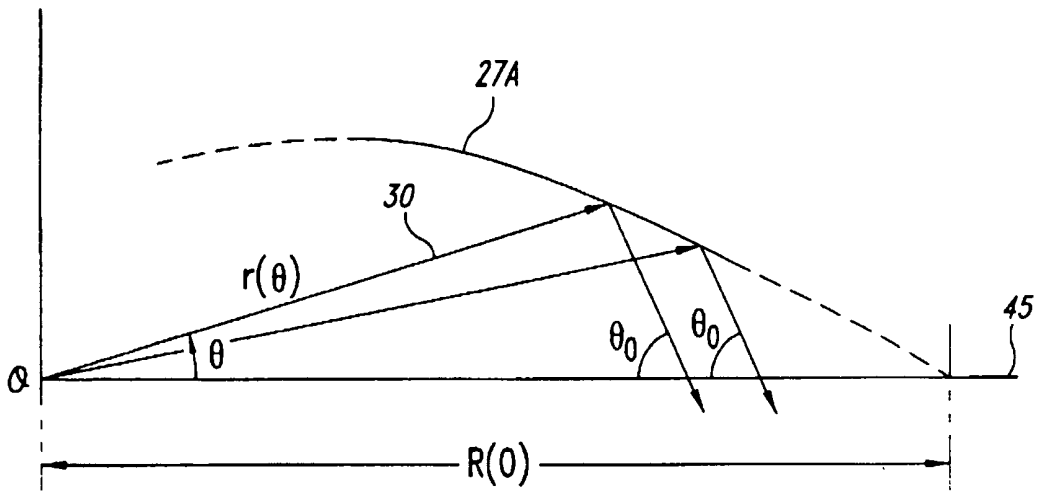

Fig. 8

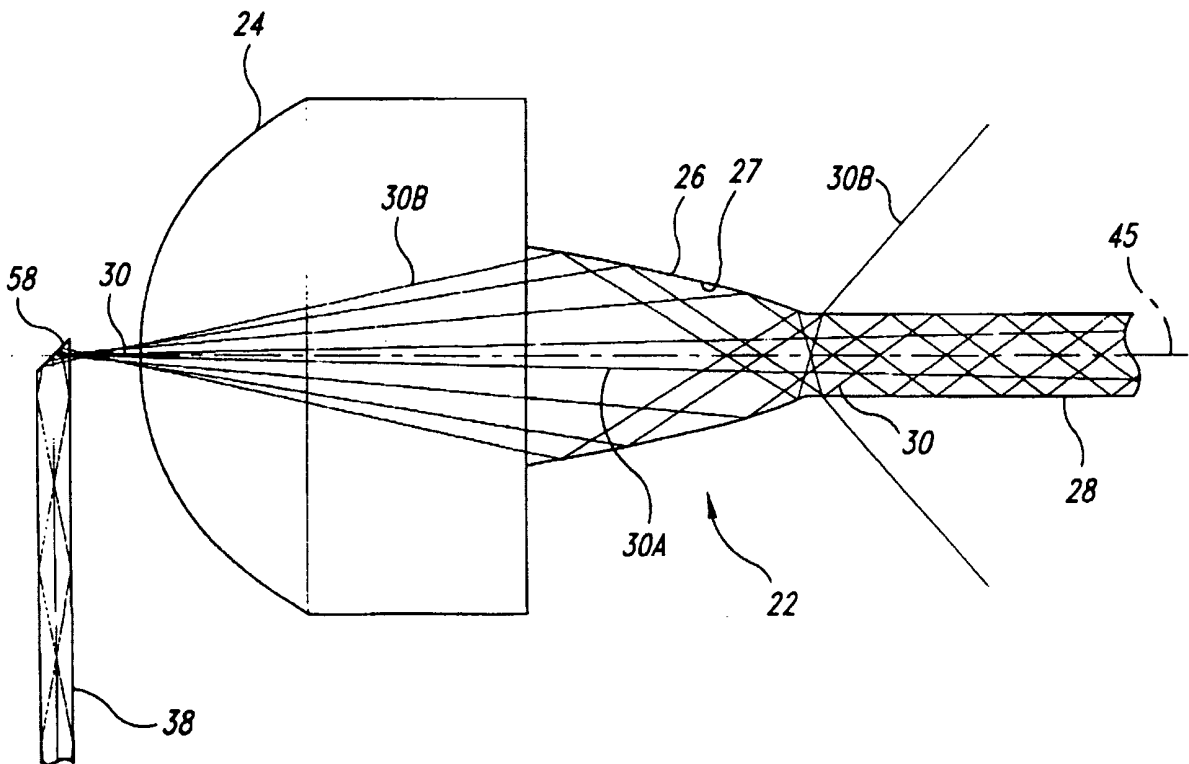

Fig. 9

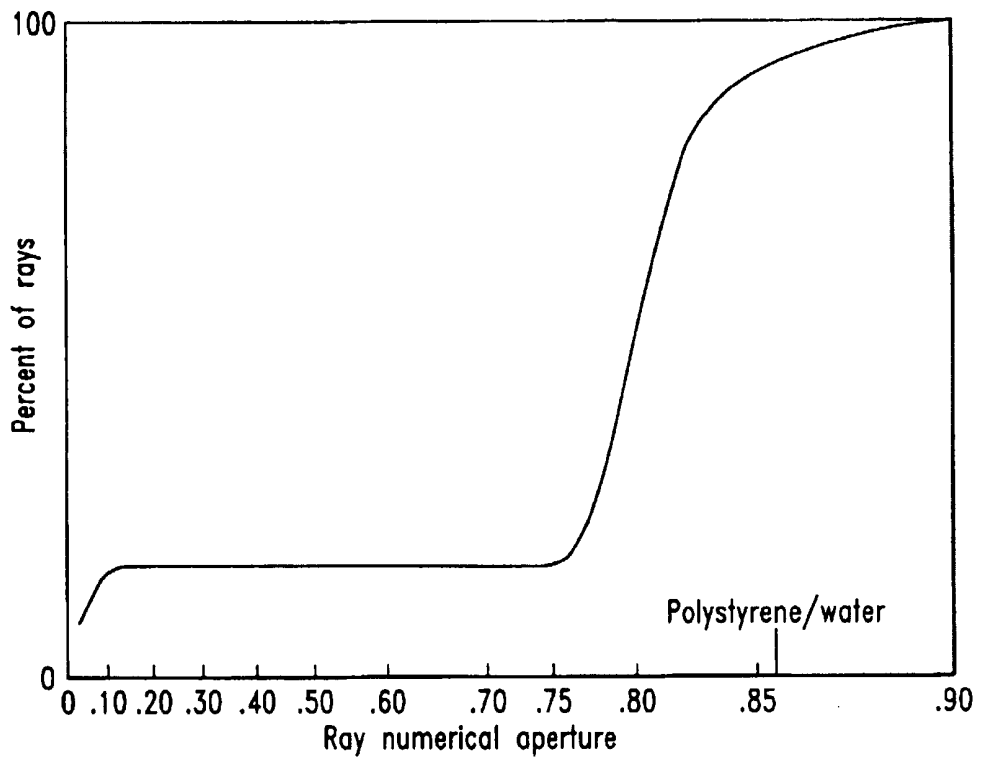

Fig. 10

$$z(\text{mm}) = 7.59178h^2 - 11.130917h^4 + 15.184765h^6 - 11.276721h^8 + 3.500005h^{10}$$

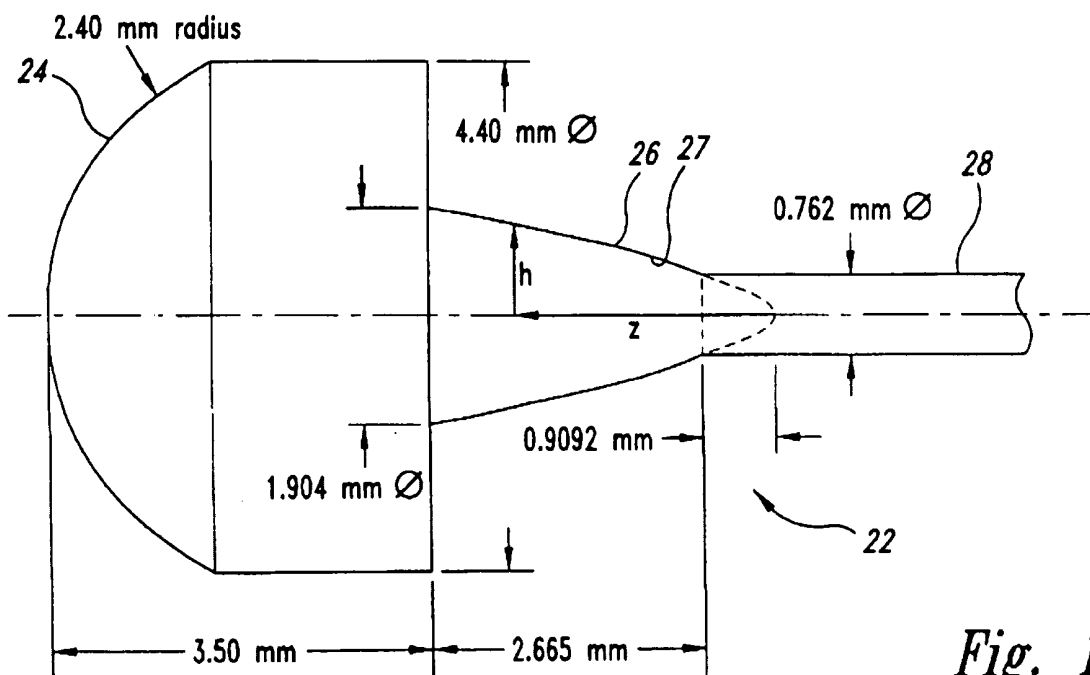

Fig. 11

9/16

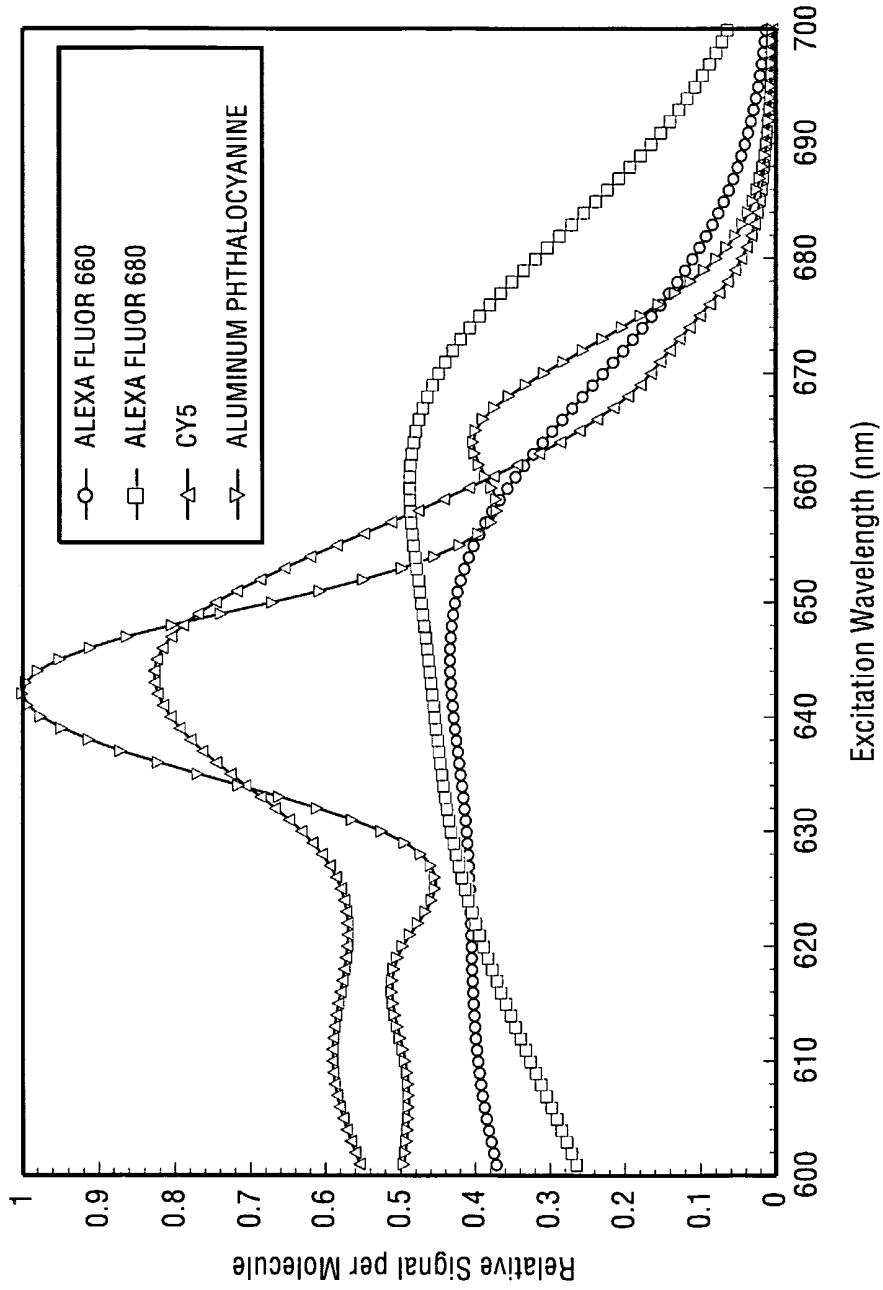

Fig. 12

10/16

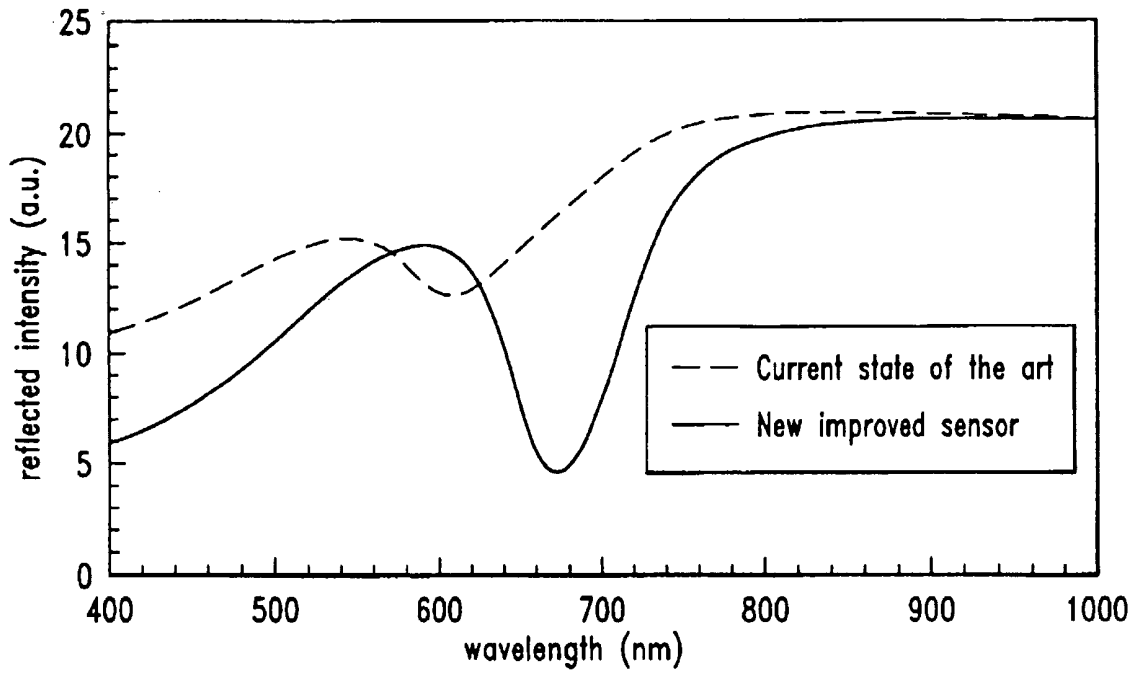

Fig. 13

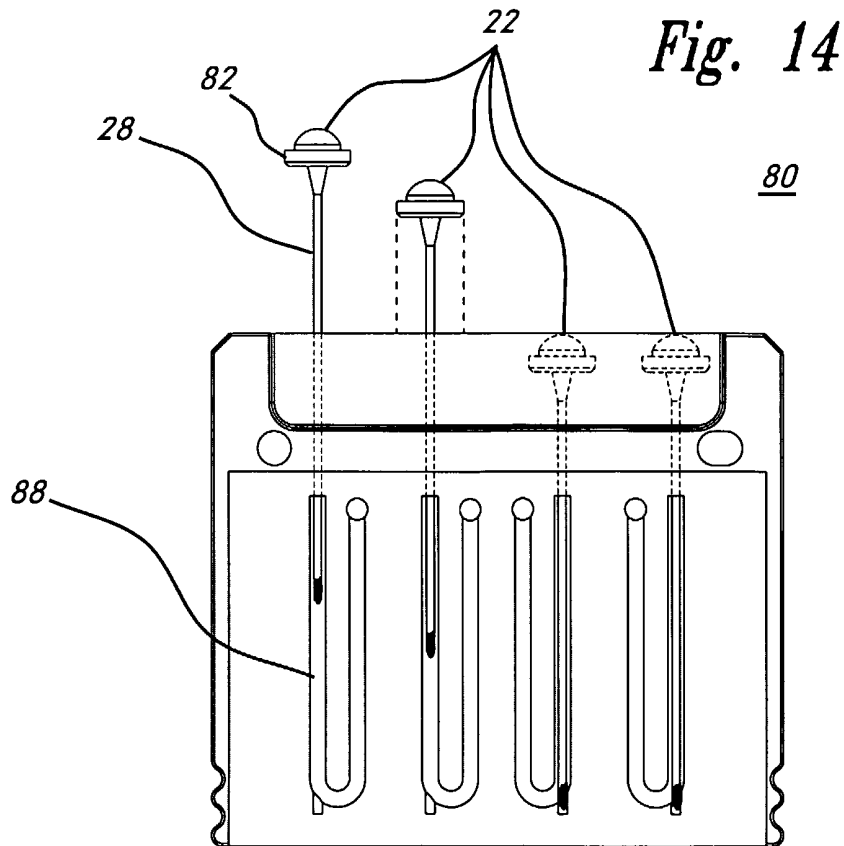

Fig. 14

11/16

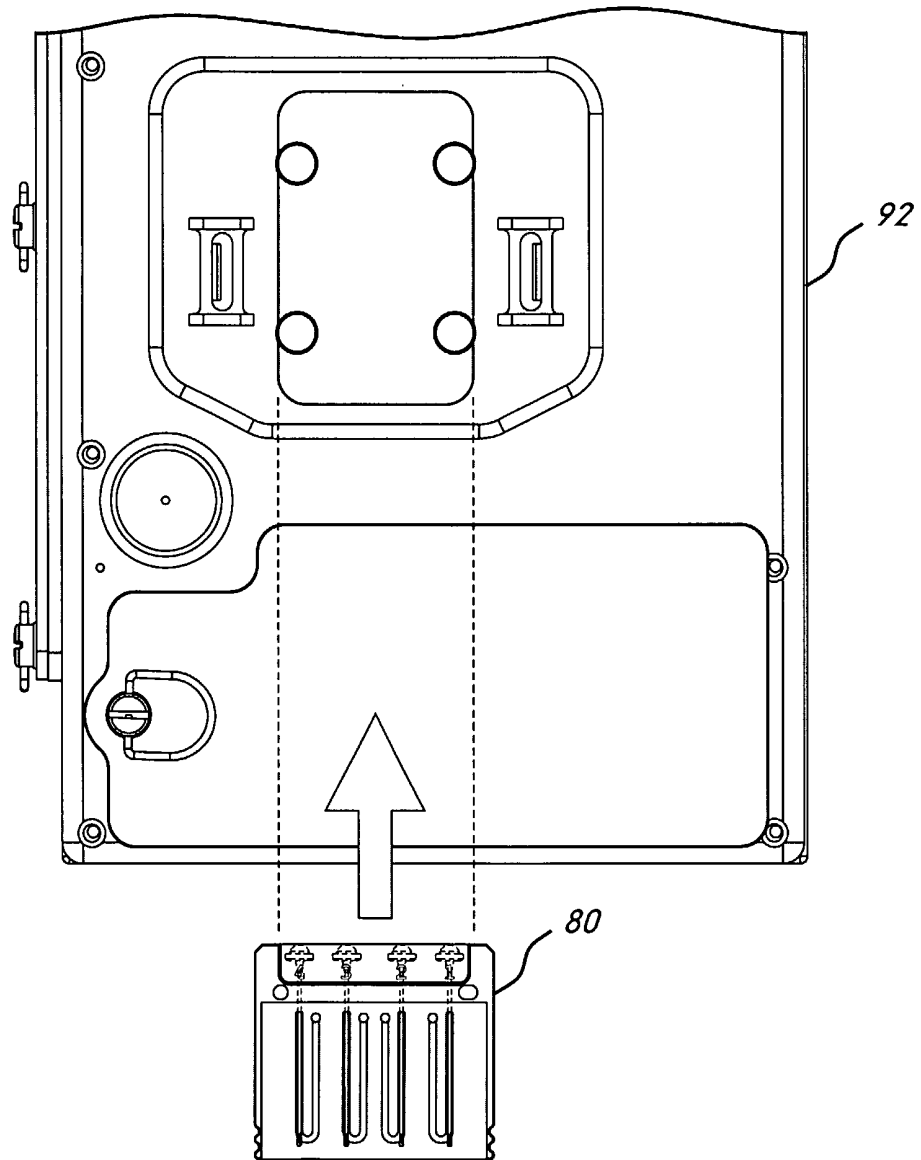

Fig. 15

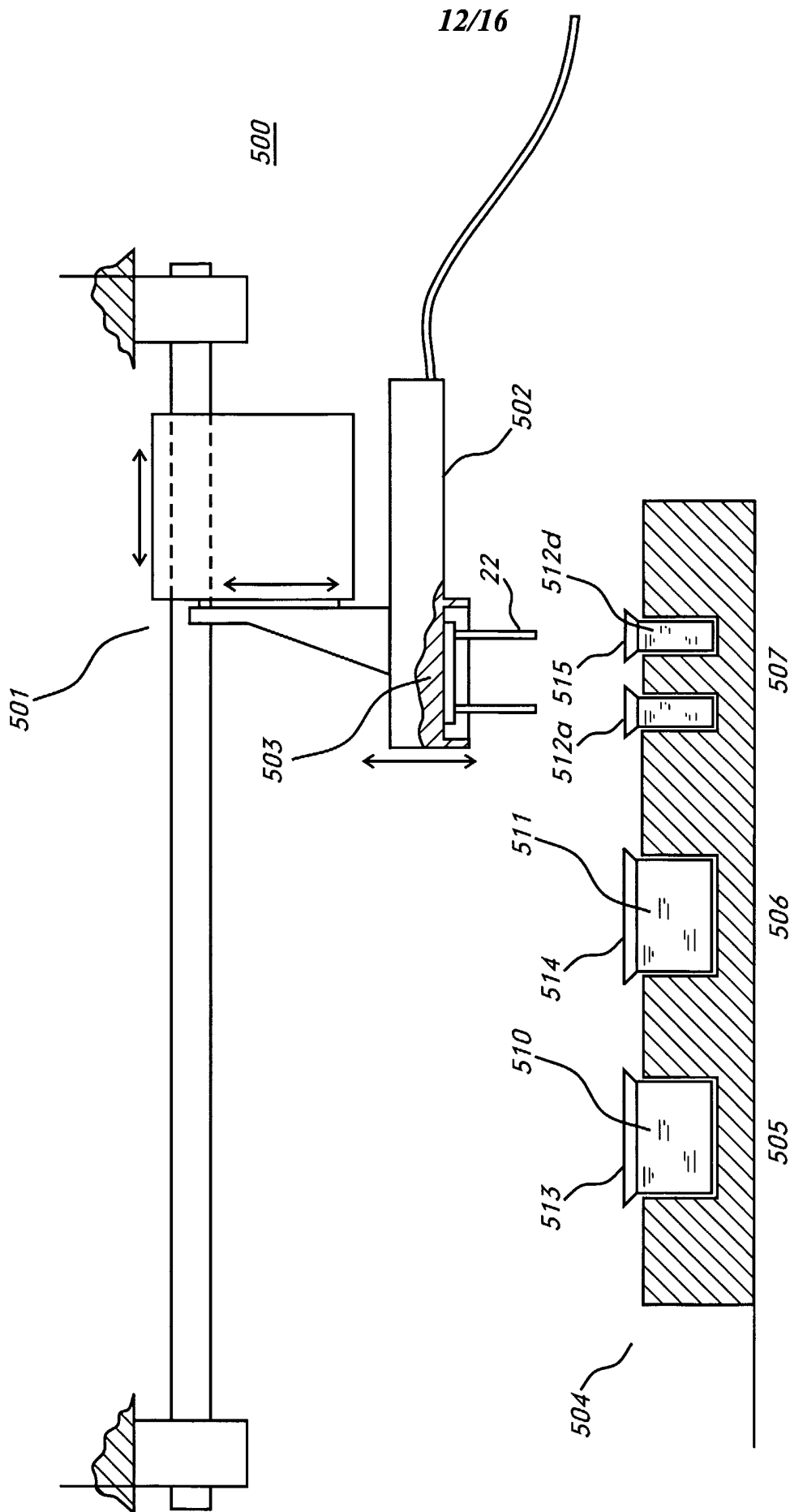

Fig. 16

13/16

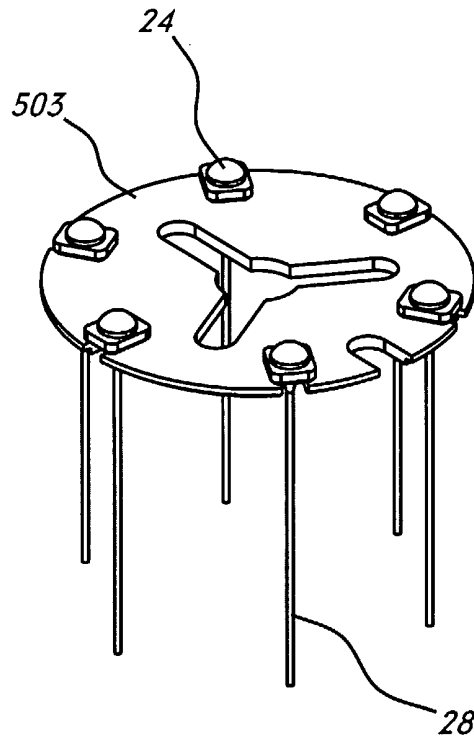

Fig. 17

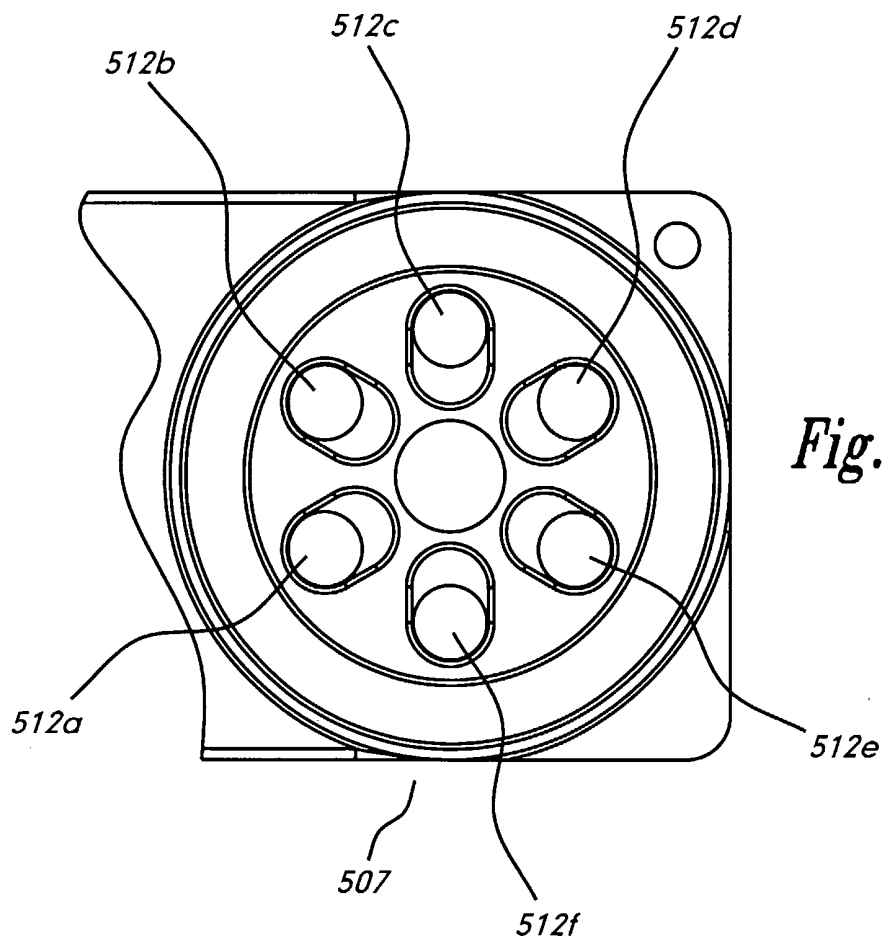

Fig. 18

14/16

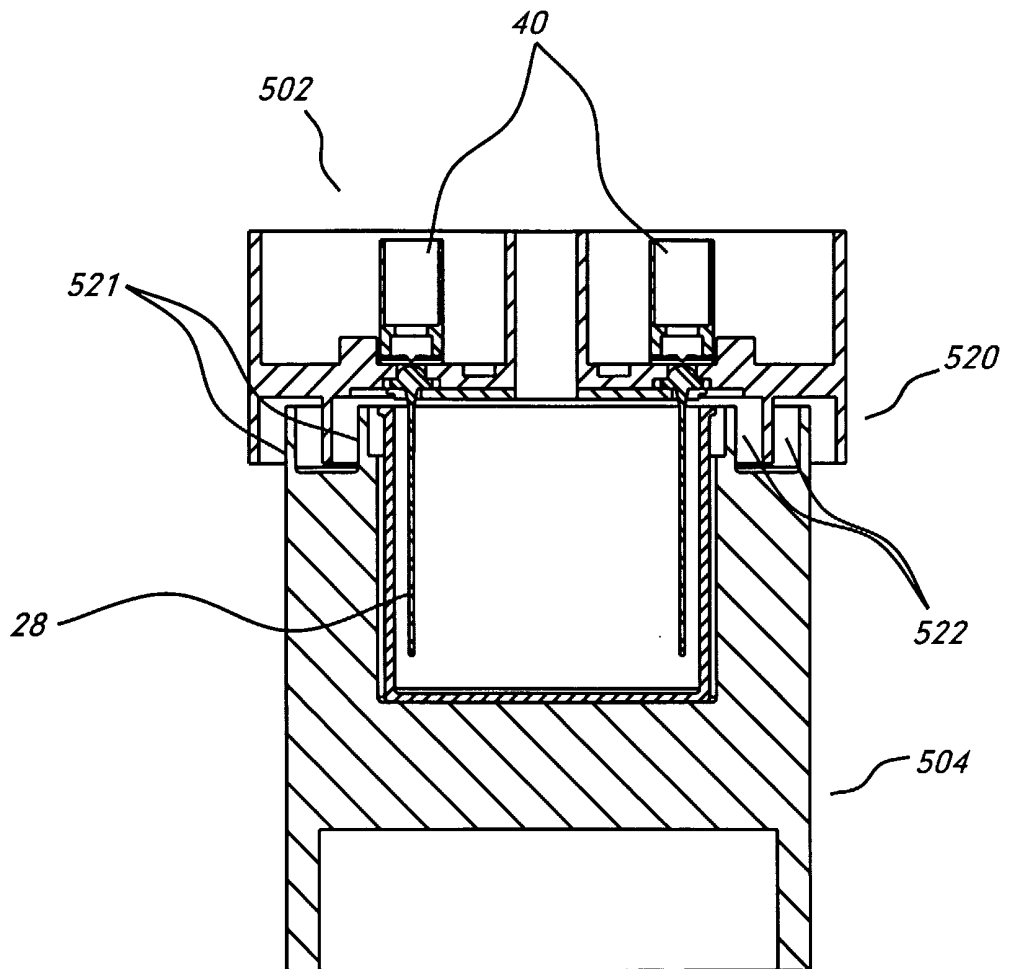

Fig. 19

15/16

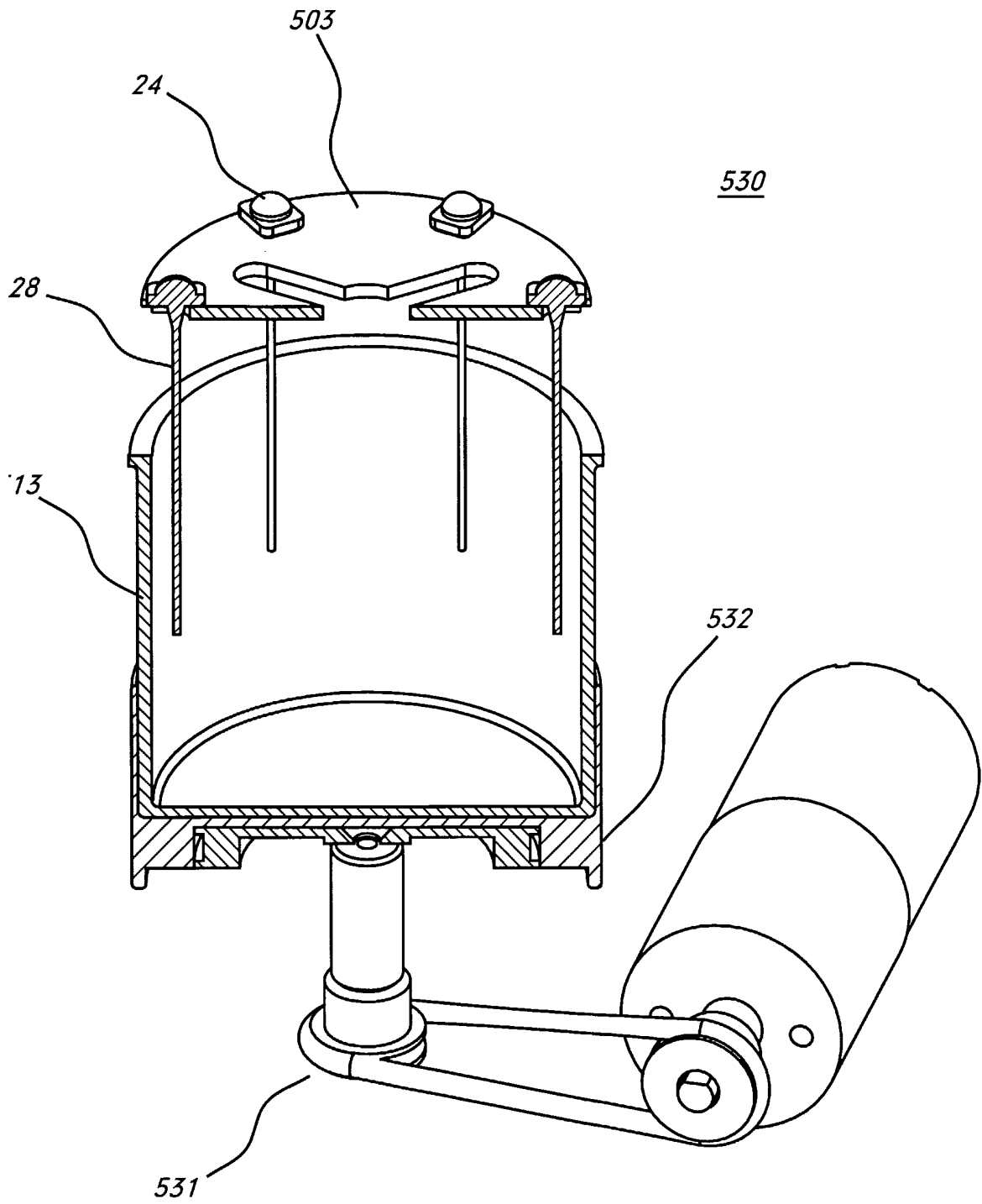

Fig. 20

16/16

Fig. 21

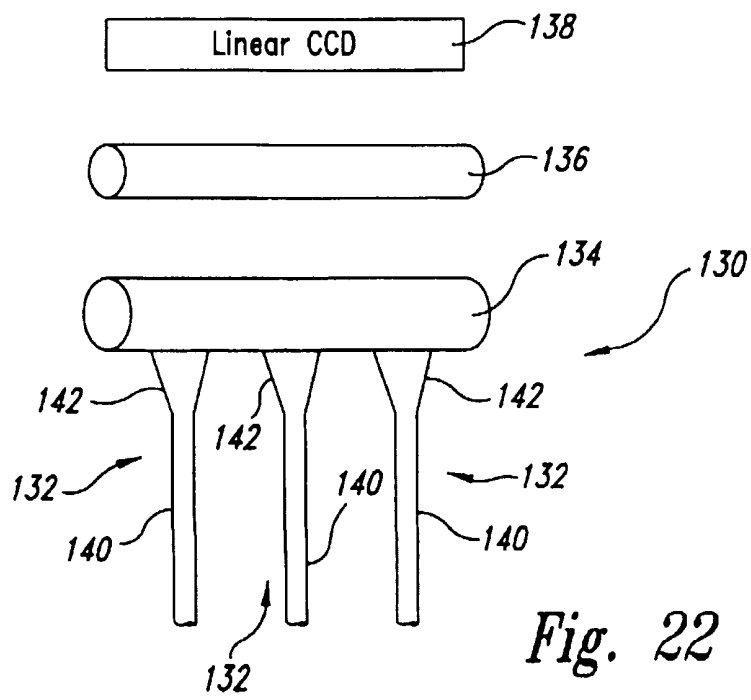
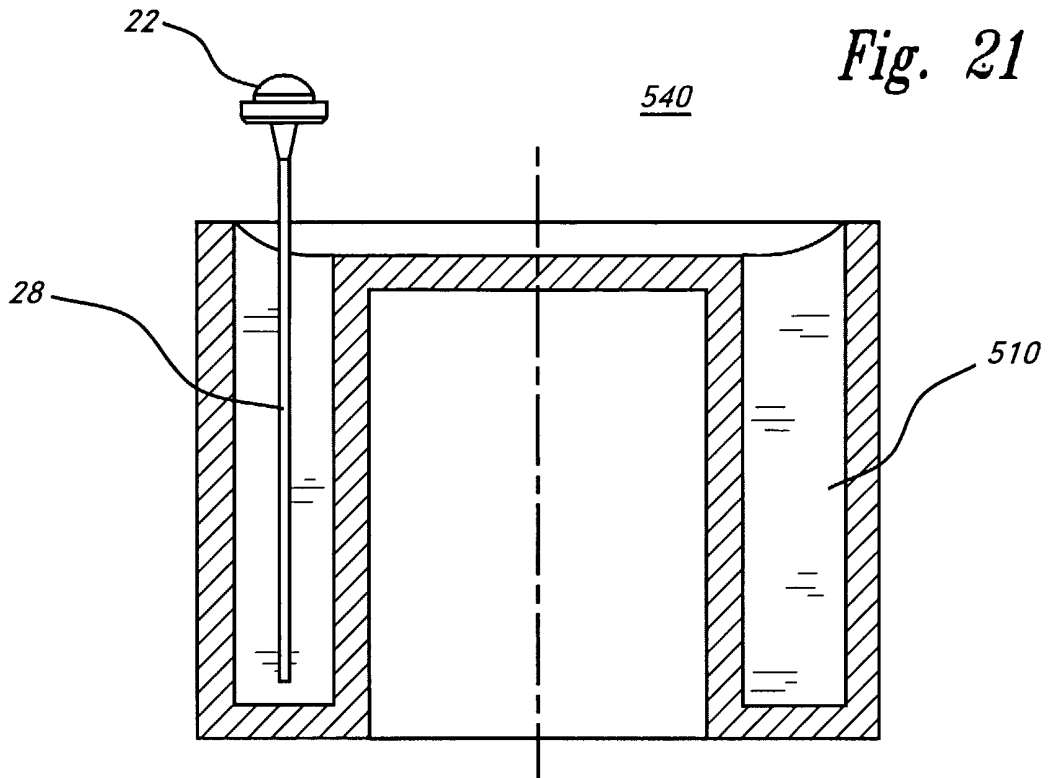

Fig. 22