



## INTERNATIONAL APPLICATION PUBLISHED UNDER THE PATENT COOPERATION TREATY (PCT)

(51) International Patent Classification <sup>6</sup> : <b>A43B</b>	<b>A2</b>	(11) International Publication Number: <b>WO 96/18317</b> (43) International Publication Date: 20 June 1996 (20.06.96)
<p>(21) International Application Number: PCT/IB95/01173</p> <p>(22) International Filing Date: 20 October 1995 (20.10.95)</p> <p>(30) Priority Data: 327,461 21 October 1994 (21.10.94) US</p> <p>(71) Applicant: ADIDAS AG [DE/DE]; Ade-Dassler-Strasse 1-2, D-8522 Herzogenaurach (DE).</p> <p>(72) Inventors: LUTHI, Simon; 5077 S.W. Denton Drive, Lake Oswego, OR 97035 (US). BEARD, Kevin, A.; Kaernter Strasse 1, D-91074 Herzogenaurach (DE). FUMY, Richard; Stadtmuhle 1, D-91315 Hoehstadt (DE). SEYDEL, Roland; 4581 S.W. Hastings Place, Lake Oswego, OR 97035 (US).</p>	<p>(81) Designated States: AL, AM, AT, AU, BB, BG, BR, BY, CA, CH, CN, CZ, DE, DK, EE, ES, FI, GB, GE, HU, IS, JP, KE, KG, KP, KR, KZ, LK, LR, LT, LU, LV, MD, MG, MK, MN, MW, MX, NO, NZ, PL, PT, RO, RU, SD, SE, SG, SI, SK, TJ, TM, TT, UA, UG, UZ, VN, European patent (AT, BE, CH, DE, DK, ES, FR, GB, GR, IE, IT, LU, MC, NL, PT, SE), OAPI patent (BF, BJ, CF, CG, CI, CM, GA, GN, ML, MR, NE, SN, TD, TG), ARIPO patent (KE, MW, SD, SZ, UG).</p> <p><b>Published</b> <i>Without international search report and to be republished upon receipt of that report.</i></p>	
(54) Title: ANISOTROPIC DEFORMATION PAD FOR FOOTWEAR		
<p>(57) Abstract</p> <p>A deformation pad is disclosed for outsoles of footwear to simulate footwear response associated with sports activity on gravel surfaces. It has been noted that there is a slight forward sliding of a shoe on a runner during each step when runners run on dirt or gravel roads. It has been theorized that this sliding minimizes impact forces on the lower leg. The present invention simulates the performance and response force characteristics of sports activities on granulated surfaces by providing a deformation pad including elongate anisotropic deformation elements having resistances to deformation that are different along longitudinal, transverse, and vertical axes. The deformation pad is designed to provide deformation along transverse and vertical axes while substantially resisting deformation along a longitudinal axis. The deformation pads may be oriented to provide optimum response characteristics for different sports having different load characteristics. For example, the deformation pads on running shoes may be oriented differently than the deformation pads on tennis shoes wherein athletes subject their shoes to substantial lateral motion and stops. Shoes having deformation pads may also be combined with support elements having a thickness less than the deformation pad. The support elements provide additional cushioning and stability and a platform for pushing off when initiating movement of the foot.</p>		

**FOR THE PURPOSES OF INFORMATION ONLY**

Codes used to identify States party to the PCT on the front pages of pamphlets publishing international applications under the PCT.

AT	Austria	GB	United Kingdom	MR	Mauritania
AU	Australia	GE	Georgia	MW	Malawi
BB	Barbados	GN	Guinea	NE	Niger
BE	Belgium	GR	Greece	NL	Netherlands
BF	Burkina Faso	HU	Hungary	NO	Norway
BG	Bulgaria	IE	Ireland	NZ	New Zealand
BJ	Benin	IT	Italy	PL	Poland
BR	Brazil	JP	Japan	PT	Portugal
BY	Belarus	KE	Kenya	RO	Romania
CA	Canada	KG	Kyrgystan	RU	Russian Federation
CF	Central African Republic	KP	Democratic People's Republic of Korea	SD	Sudan
CG	Congo	KR	Republic of Korea	SE	Sweden
CH	Switzerland	KZ	Kazakhstan	SI	Slovenia
CI	Côte d'Ivoire	LI	Liechtenstein	SK	Slovakia
CM	Cameroon	LK	Sri Lanka	SN	Senegal
CN	China	LU	Luxembourg	TD	Chad
CS	Czechoslovakia	LV	Larvia	TG	Togo
CZ	Czech Republic	MC	Monaco	TJ	Tajikistan
DE	Germany	MD	Republic of Moldova	TT	Trinidad and Tobago
DK	Denmark	MG	Madagascar	UA	Ukraine
ES	Spain	ML	Mali	US	United States of America
FI	Finland	MN	Mongolia	UZ	Uzbekistan
FR	France			VN	Viet Nam
GA	Gabon				

ANISOTROPIC DEFORMATION PAD FOR FOOTWEARBackground of the InventionField of the Invention

This invention pertains to footwear and, more  
5 particularly, pertains to outer soles for footwear.

Description of Related Art

Footwear intended for physical activity includes an  
upper and a securely attached sole. The upper wraps  
around some or all of a wearer's foot, and is typically  
10 held in place by shoelaces. Soles typically include an  
inner sole, a midsole, and an outsole. Midsoles are  
generally formed of a cushioning material while outsoles  
are wear-resistant layers. Overall soles are designed  
to provide stability and absorb impact loading caused by  
15 the foot of a wearer coming down upon the ground.

Significant engineering goes into providing and  
balancing design parameters for stability and  
cushioning. Special EVA foam materials have been  
formulated for use in midsoles. Various manufacturers  
20 have incorporated devices in the midsole to provide  
stability, cushioning, or, hopefully, both. For  
example, one major footwear manufacturer incorporates an  
air bag that is filled with a high molecular weight gas  
in order to provide substantial cushioning underneath  
25 the heel of the wearer. That manufacturer also provides  
midsole structure to enhance sole stability that is lost  
due to the presence of the air bag. Another  
manufacturer has used a gel-filled bag in the midsole to  
absorb impact. Another manufacturer provides  
30 "cantilever" technology to provide cushioning with a  
goal toward a minimum loss of stability.

Examples of devices designed to provide stability  
include heel counters, variable density EVA foams in the  
midsole, and inelastic straps going from the fore foot  
35 to the heel section of the shoe.

It is common knowledge in the footwear industry  
that a runner will experience less leg fatigue and  
muscle and joint stress by running on a dirt road than

-2-

on a paved road over equal distances. Folklore has always attributed the difference to the theory that the dirt road provides a softer or more cushioned surface upon which to run. However, empirical tests have  
5 suggested that many dirt roads are just as hard as paved roads when measured under vertical impact loading. The applicants of the present invention have therefore theorized that dirt roads may provide the advantage of a small amount of sliding each time a runner's foot  
10 contacts the ground.

When running on a dirt road, the runner's foot will go through a forward motion until it makes initial contact with the ground whereupon it slides forward slightly until coming to a rest. This action is  
15 repeated for each step. Because impact is measured as force divided by the amount of time the force is applied, the impact on a leg is lessened by the foot's sliding because the force of each step is applied over a greater amount of time. This is contrasted with running  
20 on pavement wherein the foot moves forward between steps and upon initial ground contact the foot comes to an immediate halt without any substantial forward sliding. Thus, the impact load on the foot, and hence the leg, is substantially greater.

25 Additionally, runners run with their knees bent. Thus, the lower leg forms a pivot point at the knee. During the time that the foot transitions from forward motion to a dead stop there is a rearward force (friction) on the bottom of the shoe by the ground which  
30 acts to pivot the lower leg about the knee, thus creating a moment at the knee joint. This moment must be resisted, in part, by the quadriceps and knee ligaments. It is the applicant's theory that when a runner runs on a dirt or gravel road the small amount of  
35 forward sliding that occurs upon each footfall reduces the moment at the knee due to impact loads because the amount of time that the load is applied is increased while the magnitude of the load does not change.

-3-

Similar kinematics apply to sports other than running. When tennis is played on a clay court the players experience some sliding each time a foot plant is performed. Conversely, when tennis is played on an asphalt court players may experience greater muscle fatigue because the foot cannot slide during sudden stops thus creating greater impact.

#### Summary of the Invention

The present invention seeks to advance the state of the art of athletic footwear by providing anisotropic deformation pad(s) that can be applied to the shoe soles to simulate the sliding that occurs when running on a dirt road. The pad provides a small amount of horizontal relative movement between a lower, ground-contacting surface of the pad and the footwear. The deformation pads can be applied to running shoes to simulate slight forward sliding action, or alternatively the pads may be applied at a different orientation to tennis shoes to simulate the effect of sliding sideways on a clay surface. It is further envisioned that the anisotropic nature of the deformation pads will permit them to be applied to all athletic footwear in varying orientations to specifically address the performance needs of each sport.

The deformation pads of the present invention have many preferred embodiments. In one preferred embodiment, the deformation pads include several depending, elongate, deformation elements having interior chambers, or channels. The deformation elements are arranged on a flat surface substantially radially about a common center, much as the toes of a bird are arranged around its leg. The chambers are preferably sealed and have atmospheric pressure air in them so that as the channel is deformed, air pressure builds quickly to assist in cushioning the impact load. Other preferred embodiments include filling the channels with a gelatinous, or viscoelastic, material(s) to further dampen impact loads due to footfall.

-4-

In another preferred embodiment, the pads include a plurality of deformation elements depending from a substantially flat surface wherein the deformation elements are arranged parallel to one another and oriented on the shoe to address particular performance characteristics of the sport for which the shoe is intended.

In another preferred embodiment, the deformation pad is provided with a plurality of depending deformation elements that are arranged concentrically about a common center. The deformation elements may be diamond shaped or square shaped, etc., to provide various desired anisotropic properties.

In another preferred embodiment of the present invention, the footwear sole is provided with several anisotropic deformation pads and several isotropic support elements. Preferably, the deformation pads are thicker than the support elements so that upon initial ground contact, the deformation pads would contact the ground first, and the support elements would contact the ground only after the deformation pads are at least partially deformed. The deformation pads may be placed at points of high impact or maximum loads such as at the heel and underneath the ball of the foot. The support elements may then be arranged to provide additional stability and foot support where required such as along the toe and along the midfoot section underneath the arch of the foot. Positioning a support element at the toe of the shoe may also assist with push-off.

Various advantages and features of novelty which characterize the invention are particularized in the claims forming a part hereof. However, for a better understanding of the invention and its advantages, reference should be had to the drawings and to the accompanying description in which there is illustrated and described preferred embodiments of the invention.

### Brief Description of the Drawings

Fig. 1 is a partial side elevation view showing a shoe upper connected to a midsole and an outsole having deformation pads and support elements arranged and  
5 constructed in accordance with a preferred embodiment of the present invention.

Fig. 2 is a bottom plan view of the shoe of Fig. 1.

Fig. 3 is a perspective view of a preferred embodiment of an anisotropic deformation pad of the  
10 present invention.

Fig. 4 is a cross section view taken along line 4-4, showing the deformation pad in an undeformed state.

Fig. 5 is a cross section view taken along line 4-4, showing the deformation pad in one exemplary deformed  
15 state.

Fig. 6 is a bottom plan view of a sole having an alternate preferred embodiment of anisotropic deformation pads and support elements in accordance with the present invention.

20 Figs. 7 and 8 are graphical representations of measurements of force of a single footfall of a person wearing footwear running over a force plate.

### Detailed Description of the Preferred Embodiments

With reference to Figs. 1 and 2, there is shown a  
25 shoe 10 including an upper 12, a midsole 14, and an outsole 16 having a plurality of deformation pads 18a, 18b (collectively 18) and support elements 20. Preferably, the deformation pads 18 are thicker than the support elements 20 such that if an unweighted shoe 10  
30 were placed on a level surface, the deformation pads 18 would contact the surface and the support elements 20 would not.

Fig. 2 shows a preferred embodiment for the arrangement of the deformation pads 18 and support  
35 elements 20. This distribution of pads and elements is a proposed arrangement for a court shoe such as basketball or tennis which requires substantial lateral movement and stopping. The pads 18 are placed at points

-6-

where the foot receives the greatest pressure during footfall, namely at the heel and the ball region of the foot. The pads 18 are oriented to facilitate the rapid starts, stops and direction changes associated with court games. Support elements preferably are provided at the toe section to assist with push-off and at two positions just forward of the heel to provide stability and extra cushioning when the rearward deformation element 18a deforms substantially. It is envisioned that shoes intended for other sports and activities could have other pad and support element arrangements optimized to suit the particular sport or activity.

As shown in Fig. 2, the midsole 14 has a midfoot Section 22 which is exposed. Alternatively, the midsole 14 could be provided with a wear resistant outer covering to prevent degradation of the midsole, which is typically an EVA foam.

A preferred embodiment of an anisotropic deformation pad 18 of the present invention is shown in Fig. 3. The pad includes a base layer 24 to which a plurality of elongate walls 26 are attached. Pairs of adjacent walls 26 are interconnected by ground-contacting surfaces 28 to form deformation elements 36, 38, 40, and 42, and thereby define a plurality of elongate interior channels 30. The channels 30 are completely enclosed and sealed by base layer 24 and end walls (unnumbered) which seal off the opposite ends of the channels. The pad also includes a plurality of hollow, intermediate ribs 32 located in slots or recesses formed between adjacent channels 30.

Overall, the deformation elements 36, 38, 40 and 42 are arranged on the base layer 24 as the toes of a bird's foot are arranged, that is, somewhat radially about a common center. As is discussed in detail below, many alternative configurations may be used and still provide the advantages of the present invention.

Preferably, the deformation elements 36, 38, 40 and 42 are vacuum formed or molded of a rubber or a

similar material having suitable structural strength and wear resistance. The complete pad 18 is formed by joining the formed deformation elements 36, 38, 40 and 42 to the base layer 24.

5           As noted, the channels 30 are sealed chambers. Preferably, the chambers contain air at atmospheric pressure. When the deformation pad 18 is subjected to forces causing the deformation elements to deform, the channels 30 will be compressed, thus compressing the  
10           inside air causing its pressure to increase. Alternatively, the channels 30 may be filled with a suitable gelatinous material, such as a viscoelastic plasticized PVC manufactured by Spenco, Inc. of Waco, Texas, as is disclosed in U.S. Patent No. 5,330,249.  
15           Other suitable high viscosity fluids may also be used.

          Figs. 4 and 5 show cross section views of the anisotropic deformation pad 18 of Fig. 3. In Fig. 4, the deformation pad 18 is shown in an undeformed state as it would appear when applied to a shoe 10 but having  
20           no loads placed on it. In alternative embodiments, such as disclosed in Fig. 6, discussed below, the base layer 24 may be concave upward to conform to a rounded midsole at the heel region.

          Fig. 5 depicts the deformation pad 18 as it might  
25           appear when placed under a transverse load. It can be seen that the walls 26 and the ground contacting surfaces 28 of the deformation elements 36, 38, and 40 are deformed, causing the ground contacting surfaces 28 to be shifted horizontally relative to the base surface  
30           24. The deformation causes the channels 30 to deform, and because the channels are sealed, the pressure of the fluid within the channels will increase providing added cushioning.

          The deformation exemplified in Fig. 5 is caused by  
35           the forces associated with ground contact during sports activity. Generally, the forces associated with footfall will have x, y and z components, where x is transverse to a lateral margin of the shoe 10, y is

longitudinal and z is vertical. Thus each force F will have components  $F_x$ ,  $F_y$  and  $F_z$ .  $F_x$  and  $F_y$  components will tend to urge the ground-contacting surface 28 to shift horizontally relative to the base layer 24 and the  
5 midsole 14. The  $F_z$  component will be a purely compressive force urging the ground-contacting surface 28 to move toward the base layer 24 without any horizontal shift. The performance of the deformation pads 18 depend upon the orientation of the deformation  
10 elements 36, 38, 40, and 42 relative to each other and to the forces  $F_x$  and  $F_y$ , as described below in detail with reference to axes a, b, c, and d.

Transverse deformation of each element, e.g. 36, is caused by a force, e.g.  $F_x$  or  $F_y$ . The amount of  
15 deformation will depend upon the orientation of the element to the force and on the resistance to deformation inherent in the physical properties of the element. The performance of the elements can be equated with the performance of a spring, that is the amount of  
20 deformation will equal the force times a proportionality factor or coefficient, which may be linear or nonlinear.

The performance of the deformation pads 18 will also depend upon the interaction of other design factors. Notably, the size of the channels 30 relative  
25 to the structural strength of the walls 26. Thicker walls 26 and smaller channels 30 will likely produce greater stability and less cushioning.

Additionally, the walls of opposing channels 30 may be spaced closely so as to make contact during  
30 deformation causing a two-stage resistance to deformation: the first stage occurring upon initial ground impact, and a second stage occurring when the walls collide causing increased resistance to further deformation. Further, the walls 26 of channels 30 may  
35 be spaced closely to ribs 32 so as to collide upon deformation, again establishing a two-stage resistance to deformation similar to that described above. Additionally, the size of the channels 30 may be

enlarged or reduced without a change in the thickness of walls 26 to further adjust the cushioning of the deformation pad 18. Additional design options which would affect performance include changing the width and height of the deformation elements 36, 38, 40 and 42, changing their relative orientation, and changing their shape, e.g., tapered or "cigar-shaped."

It must be noted that under typical deformation loads, the ground contacting surfaces 28 will conform to the ground surface upon which they rest causing the base layer 24 to assume an incline. The amount of inclination may be controlled by the resistance to deformation of deformation pad 18. The inclination of the base layer 24 will only occur in connection with forces  $F_x$  and  $F_y$ . Purely vertical forces,  $F_z$ , will not cause an inclination.

The deformation elements 36, 38, 40 and 42 are preferably elongate having vertical, longitudinal and transverse axes. The deformation elements are designed to deform primarily along the transverse and vertical axes. Conversely, the deformation elements will substantially resist deformation along their longitudinal axes.

This anisotropic deformation is better understood by reference to Fig. 2 wherein axes a, b, c, and d, are shown superimposed on deformation pad 18a. It can be seen that axes a and b are the longitudinal axes for deformation elements 36 and 38, respectively. Axes c and d are transverse axes for deformation elements 36 and 38, respectively. For clarity of illustration and ease of explanation, reference axes for deformation elements 40 and 42 are not shown or described.

Forces acting along transverse axis d on deformation element 38 will cause its respective ground-contacting surface 28 to shift substantially horizontally relative to the base surface 24 and the midsole 14. This relative motion simulates the slight sliding that would occur when running on gravel roads or

-10-

playing tennis on a clay court. Conversely, when a force is acting on deformation element 38 along reference axis b, the element will deform very little and there will be very little longitudinal movement of its respective ground-contacting surface 28 relative to the base surface 24 or the midsole 14.

In addition, as noted, deformation element 38 will have a particular resistance to deformation against forces acting along axes b and d. That is, the amount of horizontal shift of the ground-contacting surface 28 is equal to the magnitude of the applied force times a proportionality factor which relates to the resistance to deformation. The deformation elements are designed to have their least resistance to deformation against forces acting along transverse axes, e.g., axes c and d for elements 36 and 38 respectively, and to have their greatest resistance to deformation against the forces acting along their longitudinal axes, e.g., axes a and b for elements 36 and 38 respectively.

The deformation elements 36, 38, 40 and 42 also deform vertically, that is the elements deform such that the ground-contacting surfaces 28 move directly toward the base surface 24 without any sideways (e.g., horizontal) shifting. During typical sports activity forces acting on the deformation pad will cause the deformation elements to deform transversely and vertically, simultaneously.

The embodiment of the deformation pad 18a shown in Figs. 1-3 includes deformation elements 36, 38, 40, and 42 having converging longitudinal axes. Accordingly, when the deformation pad 18a is subjected to a force during footfall, the direction of that force will assume various angles of incidence relative to the longitudinal axes of the deformation elements 36, 38, 40, and 42. For example, if the shoe 10 of Figs. 1 and 2 were subjected to a force  $F$  having a component that is transverse to the elongate shoe sole  $F_x$  it would be in a direction approximately parallel to the reference

-11-

axis c. Thus, deformation element 36 would be deformed along its axis of least resistance to deformation. Meanwhile, the force  $F_x$  would act on deformation element 38 between its axes of least resistance to deformation and most resistance to deformation; thus deformation element 38 would deform less than deformation element 36. The same analysis can be applied to elements 40 and 42.

The interaction, and the relative amounts of deformation of the various deformation elements, can thus be controlled by controlling the angle between the longitudinal axes of the respective deformation elements. For example, by increasing the angle between the longitudinal axes of the deformation elements a force which is transverse to one deformation element would be more nearly longitudinal relative to an adjacent deformation element. This arrangement would likely produce greater stability with less "sliding" effect (wherein ground-contacting surface 28 shifts horizontally relative to the base layer 24). On the other hand, if it was desired to increase the sliding effect, the angle between the longitudinal axes of the individual deformation elements would be increased; in the most extreme case, the longitudinal axes would be parallel so that a given force acting transversely on one deformation element would likewise act transversely on all the deformation elements causing equal degrees of deformation. This type of response may be desirable for certain sports activities while being undesirable for other sport activities.

In the embodiment of Figs. 1 and 2, the deformation elements 18 are arranged to provide deformation along predetermined axes when subjected to ground impact forces during footfall. Using the notation described above, it is apparent that deformation pads 18b are arranged to provide deformation primarily along the sole's longitudinal axis, e.g. in response force  $F_y$ , while providing almost no deformation along the sole's

-12-

transverse axis in response to force  $F_x$ . Conversely, deformation pad 18a, at the heel of the shoe 10, is arranged to provide minimum deformation in response to force  $F_y$  and a maximum deformation in response to a force  
5 in close alignment with  $F_x$ . The orientation of deformation pads can also be selected to provide a greater or lesser degree of transverse or longitudinal deformation as may be desired to control injury-prone motion such as overpronation.

10 Fig. 2 is not represented as an ideal or optimum arrangement, placement, or orientation of deformation pads 18 for any particular support. Rather, it reflects various design considerations and design theory for the use of the deformation pads 18. Further study and  
15 experience with the deformation pads may yield other designs and arrangements that produce more favorable results for a given sport.

The support elements 20 are preferably cushioned elements having cushioning 46 and an abrasion-resistant  
20 material 48. As noted, preferably the support elements 20 have a thickness that is less than a thickness of the deformation pads 18. Thus, as the outsole 16 encounters the ground during footfall, the deformation pads 18 will first contact the ground and deform as the load of the  
25 athlete is applied to shoe. As the deformation pads 18 deform, their thickness will decrease until the support elements 20 come into contact with the ground.

As with the design and orientation of the deformation pads, the design and placement of the support  
30 elements can be tailored to individual sports activities. In running, the support elements 20 located near the deformation pad 18a may be provided with substantial cushioning to reduce impact, while the support element 20 located at the toe is provided with  
35 dense EVA foam to facilitate push-off. Other sports applications may wish to emphasize the stability characteristics and provide a greater density foam in

-13-

the support elements 20 located near the rearmost deformation pad 18a.

Another preferred embodiment of the present invention is exemplified in Fig. 6 which shows a support  
5 element 20 at a toe of the shoe, and deformation pads 50 and 52 located at the heel and ball of the foot, respectively. The deformation pad 50 is provided with concentrically arranged square-shaped deformation  
10 elements 54 having interior channels (not shown) similar to channels 30 of the embodiment shown in Figs. 1-5. The deformation pad 52 is a one-piece pad meant to replace the two pads 18b of the embodiment of Figs. 1-5. Deformation pad 52 also includes deformation elements 56  
15 that are arranged to provide deformation along particular axes suitable for a particular sport. Between the deformation pads 52 and 50 there is a portion of exposed midsole 58 and a bottom portion of shoe upper 60.

Figs. 7 and 8 are graphs of the force on an outer  
20 sole of a shoe during footfall of a runner. The data is collected by having a runner wearing a shoe run over a force plate which measures forces along the x, y, and z axes of a single footfall wherein the y axis is parallel to the direction of travel, the z axis is vertical, and  
25 the x axis is orthogonal to the y and z axes (i.e., x and y define the horizontal plane). The ordinate axis on the graph represents the force of the foot on the force plate, and the abscissa axis represents time in milliseconds. There are no units applied to the  
30 ordinate axis because force is relative to an individual runner, the runner's speed, and posture. Accordingly, the magnitude of the force varies from test to test, even with the same runner in the same pair of shoes. However, the relationship of the forces is significant,  
35 particularly the forces acting in the y direction ( $F_y$ ) and the z direction ( $F_z$ ).

In Fig. 8, representing a runner with one type of prior art footwear, it can be seen that  $F_z$  and  $F_y$  have an

initial, equal onset. That is,  $F_z$  and  $F_y$  have equal magnitudes and rates of increase for the initial five to eight milliseconds after the shoe first makes contact with the force plate. Thereafter, the rate of increase  
5 of  $F_z$  and  $F_y$  continue equally, but at different magnitudes, until each reaches its respective maximum force. The forces thereafter subside.

The force response of a runner wearing a shoe having the deformation pads of the present invention is  
10 shown in Fig. 7. These results are a composite of results obtained using footwear of the present invention, but the pads may have been oriented differently. It can be seen that from its onset  $F_z$  has a substantially steady rate of increase up to its  
15 maximum force which occurs approximately 30 milliseconds after foot impact, not unlike the response using prior art footwear. However,  $F_y$  represents a significant difference over the prior art response because there is a 10 to 15 millisecond delay between the initial shoe  
20 contact and an increase in  $F_y$ . This delay in the onset of  $F_y$  correlates with a reduced impact felt by the runner because impact is defined as force divided by time. Thus, even though the actual magnitude of force  $F_y$  may be  
25 equal in prior art shoes and in shoes incorporating the present invention, empirical data indicates that the onset of that force is delayed. Thus, the force is applied over a longer period of time indicating a reduced impact.

The foregoing explanation includes theory regarding  
30 the reasons for the performance advantages that have been realized by the present invention. Further testing and collection of empirical data may modify some of the theory.

Numerous characteristics and advantages of the  
35 invention have been set forth in the foregoing description, together with details of the structure and function of the invention. The novel features hereof are pointed out in the appended claims. The disclosure

-15-

is illustrative only, and changes may be made in detail, especially in matters of shape, size, and arrangement of parts within the principle of the invention to the full extent indicated by the broad general meaning of the

5 terms in the claims.

CLAIMS

1. A pad for a footwear sole comprising a base surface having a plurality of depending deformation elements that each have a first resistance to  
5 deformation along a first axis and a second resistance to deformation along a second axis wherein the first resistance to deformation is greater than the second resistance to deformation.

2. The pad of claim 1 wherein the  
10 deformation elements are elongate having respective longitudinal axes and transverse axes and further comprising a third resistance to deformation along a third axis wherein the first axes are along the longitudinal axes respectively, the second axes are  
15 along the transverse axes respectively, and the third axis is substantially vertical.

3. The pad of claim 1 wherein the deformation elements include a ground-contacting surface and further comprising a third resistance to deformation  
20 along a third axis wherein the first resistance and the second resistance are reaction forces to forces urging the ground-contacting surface to shift along a plane substantially parallel to a plane of the base surface and the third resistance to deformation is a reaction  
25 force to a force urging the ground-contacting surface to move toward the base surface.

4. The pad of claim 1 wherein the deformation elements define an interior chamber containing a fluid.

5. A pad for a footwear sole, comprising a  
30 plurality of anisotropic deformation elements fixedly attached to a surface and each deformation element including a lower ground contacting surface that moves relative to the sole along a respective first axis and  
35 does not substantially move relative to the sole along a respective second axis wherein the first and second axes lie in a plane substantially parallel to the surface.

-17-

6. A sole for footwear, comprising a lower surface and having at least one anisotropic deformation element depending therefrom wherein the deformation element has a first coefficient of deformation along a first axis that is greater than a second coefficient of deformation along a second axis such that forces normal to the first axis cause a first deformation of the at least one element and forces normal to the second axis cause a second deformation that is less than the first deformation when the forces acting along the respective axes are equal.

7. A sole for elongate footwear, comprising a lower surface having at least one anisotropic pad and at least one substantially isotropic support element.

8. A shoe sole extending substantially within a sole plane, the shoe sole comprising:  
one or more deformation pads disposed thereon, each deformation pad defining one or more chambers, each chamber having a ground contacting surface that is displaceable along a plane substantially parallel to the sole plane so as to reduce impact forces on the shoe sole caused by foot strike of the shoe sole on a ground surface.

9. The deformation pad of claim 8, wherein the ground contacting surface of said deformation pad is further displaceable along a vertical axis relative to said sole.

10. The deformation pad of claim 8, wherein said chamber contains, in substantial part, a fluid.

11. The deformation pad of claim 10, wherein said fluid is air.

12. The deformation pad of claim 8, wherein said chamber contains, in substantial part, a gelatinous substance.

13. The deformation pad of claim 8, wherein said sole comprises an outsole disposed over a midsole and each said pad is secured to the outsole.

14. The deformation pad of claim 13, wherein the ground contacting surface of said deformation pad is displaceable along a vertical axis relative to the sole.

5 15. The deformation pad of claim 13, wherein said chamber contains, in substantial part, a fluid.

16. The deformation pad of claim 15, wherein said fluid is air.

10 17. The deformation pad of claim 13, wherein said chamber contains, in substantial part, a gelatinous substance.

15 18. An elongate shoe sole comprising an outer surface and an inner surface, said outer surface having one or more deformation pads disposed thereon, each said deformation pad comprising one or more chambers each having a ground contacting surface, said ground contacting surface being displaceable along transverse, longitudinal, and vertical axes relative to said sole so as to reduce the impact of foot strike, each said chamber including a ground-contacting, wear-resistant layer disposed over a deformable, cushioning layer.

20 19. The deformation pad of claim 18, wherein said sole comprises an outsole disposed over a midsole and said outer sole surface is disposed on said outsole.

25 20. The deformation pad of claim 18, wherein said cushioning layer comprises a fluid and said wear resistant layer comprises an elastomeric material.

30 21. The deformation pad of claim 18, wherein said cushioning layer comprises a gelatinous material and said wear resistant layer comprises an elastomeric material.

FIG. 1

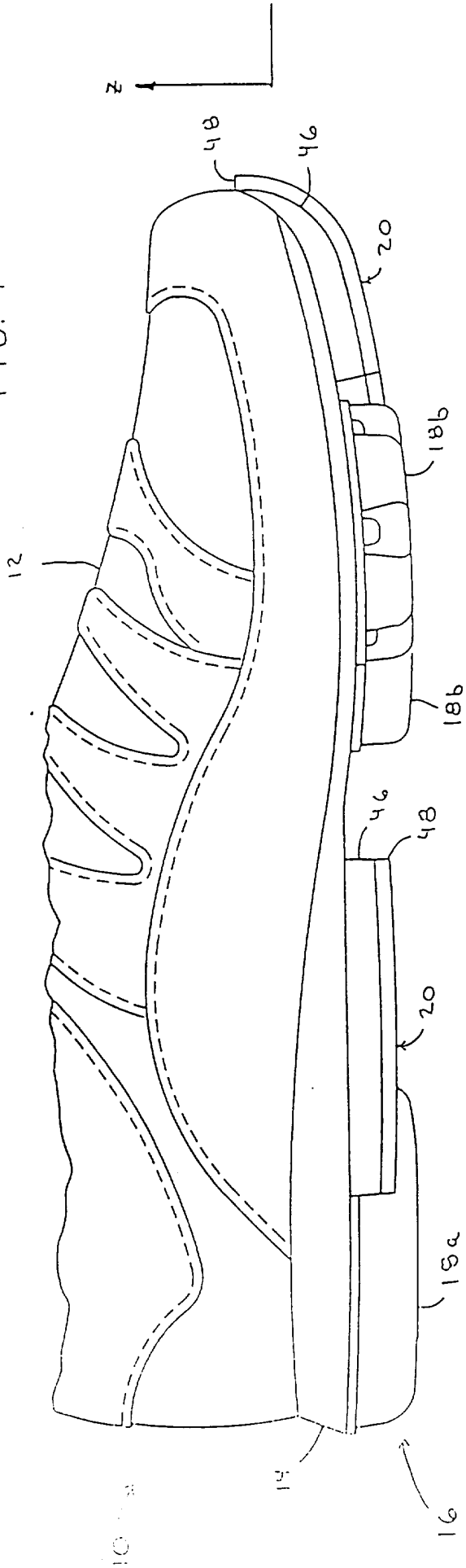

FIG. 2

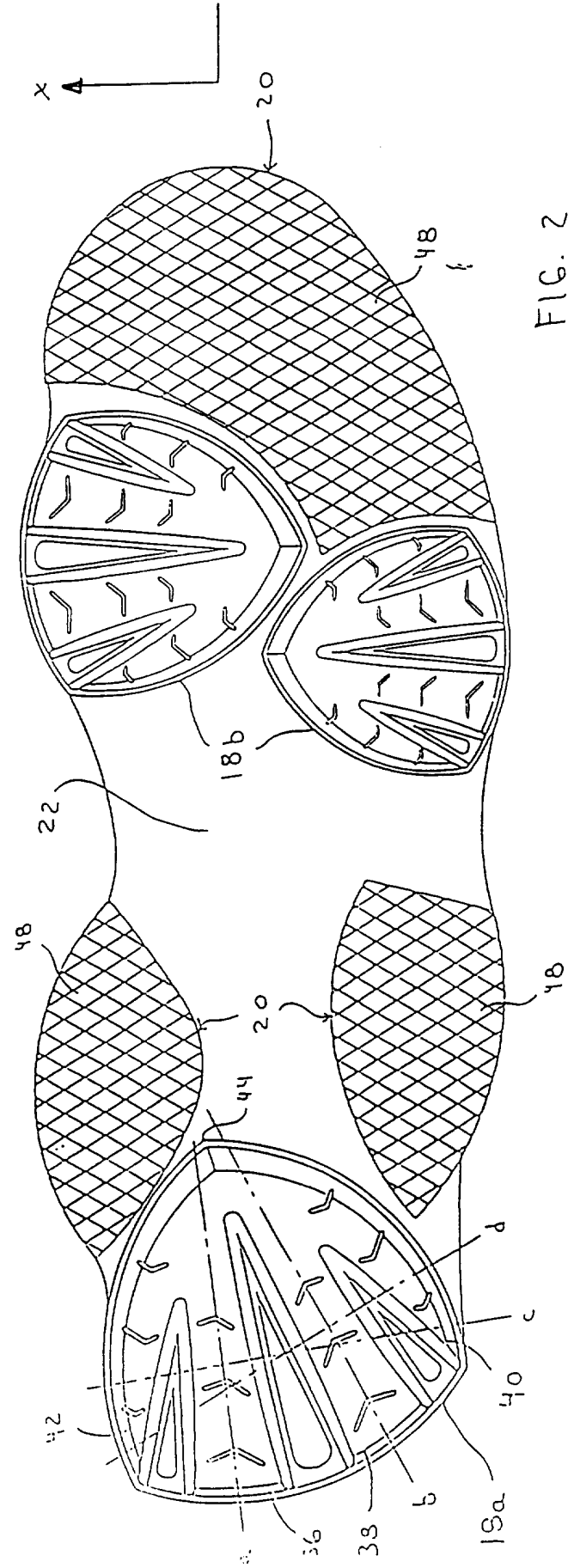
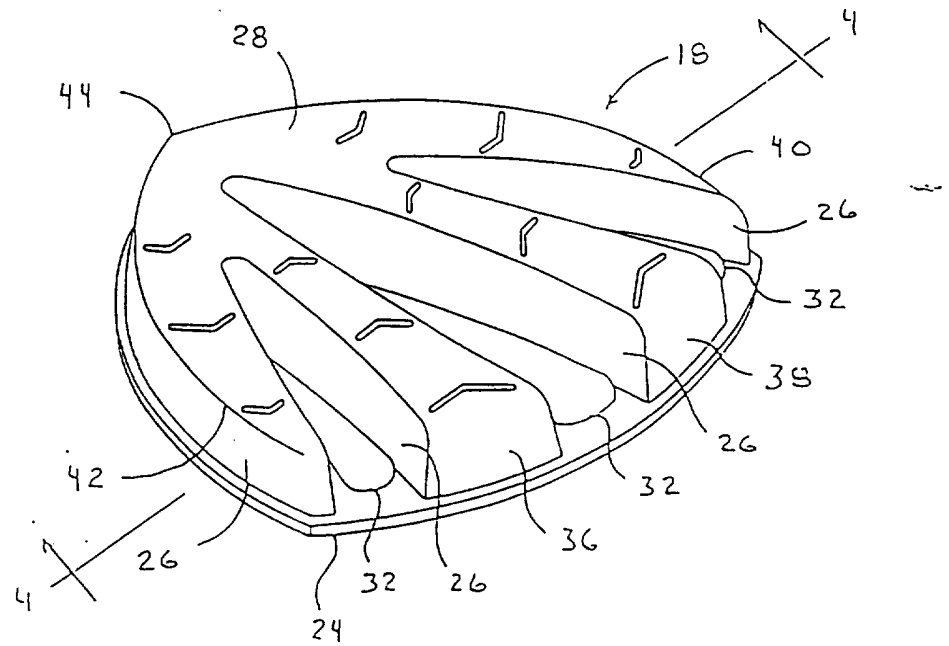

FIG. 3



18 →

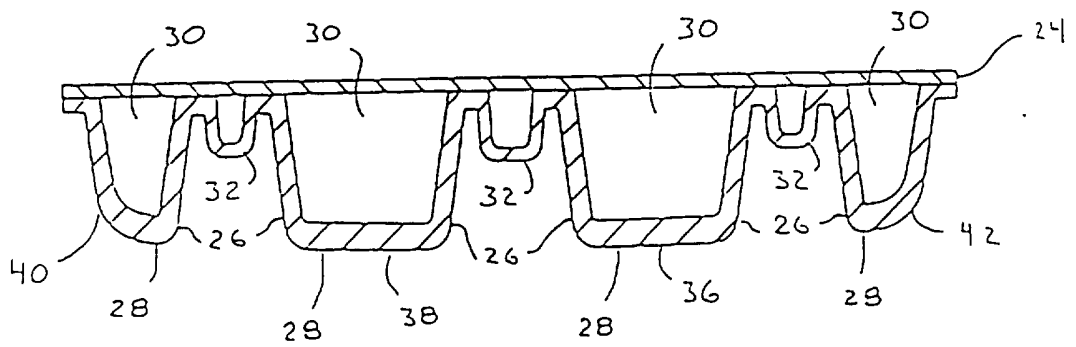

FIG. 4

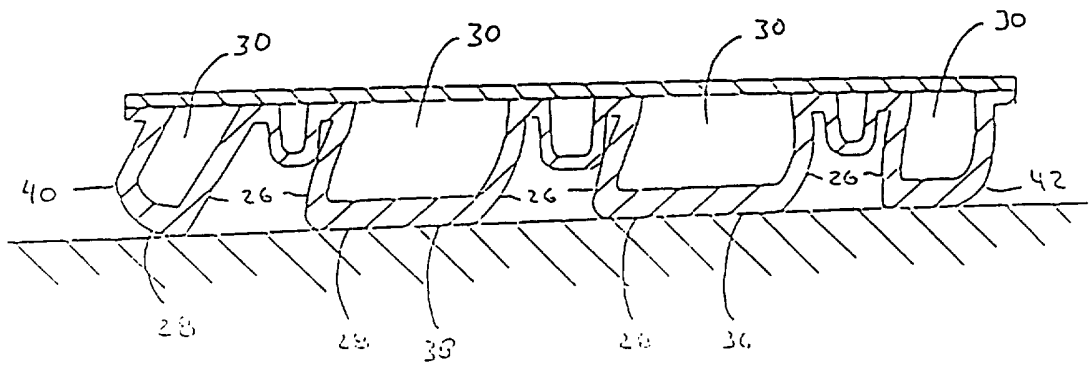

FIG. 5

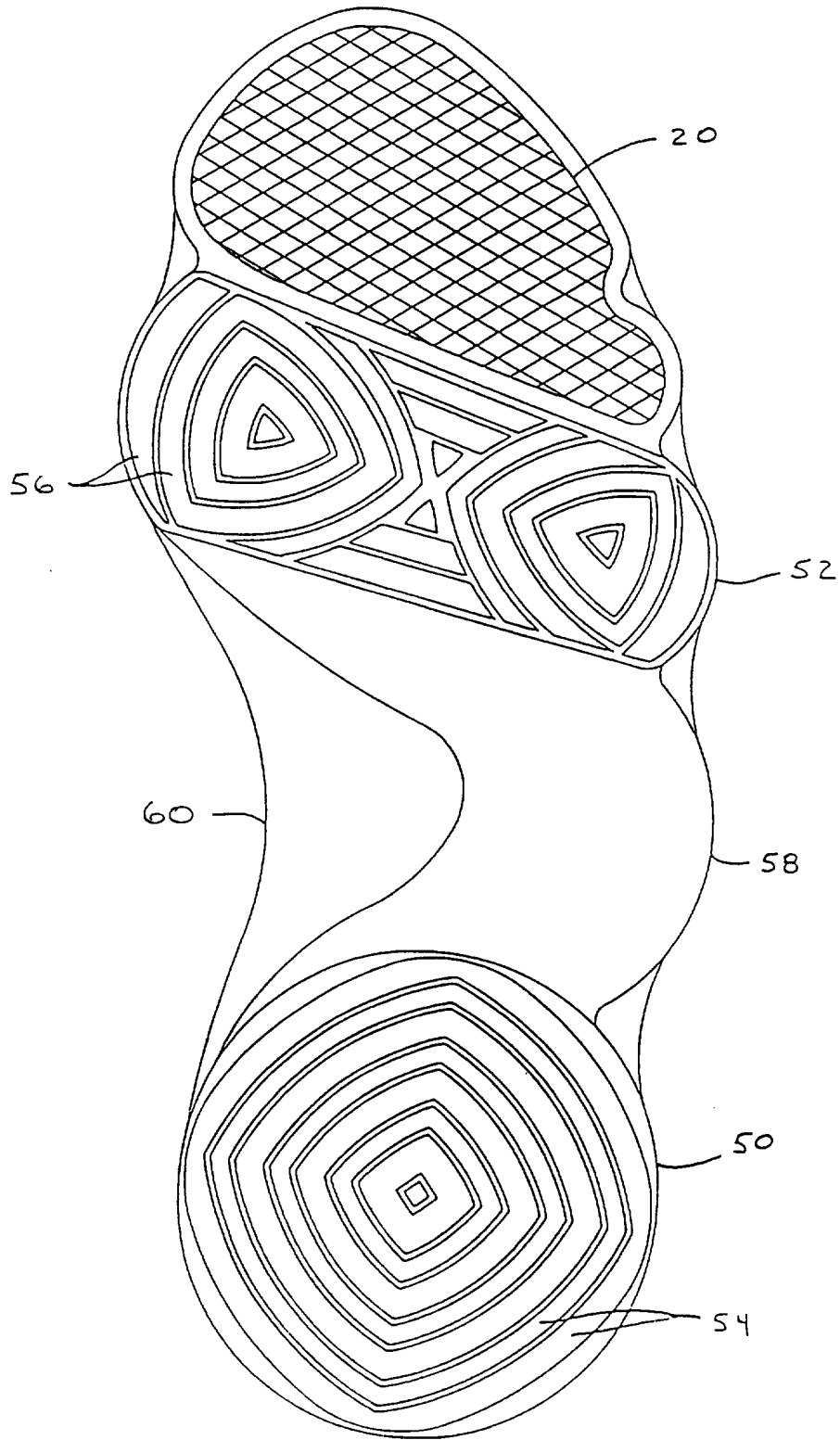

FIG 6

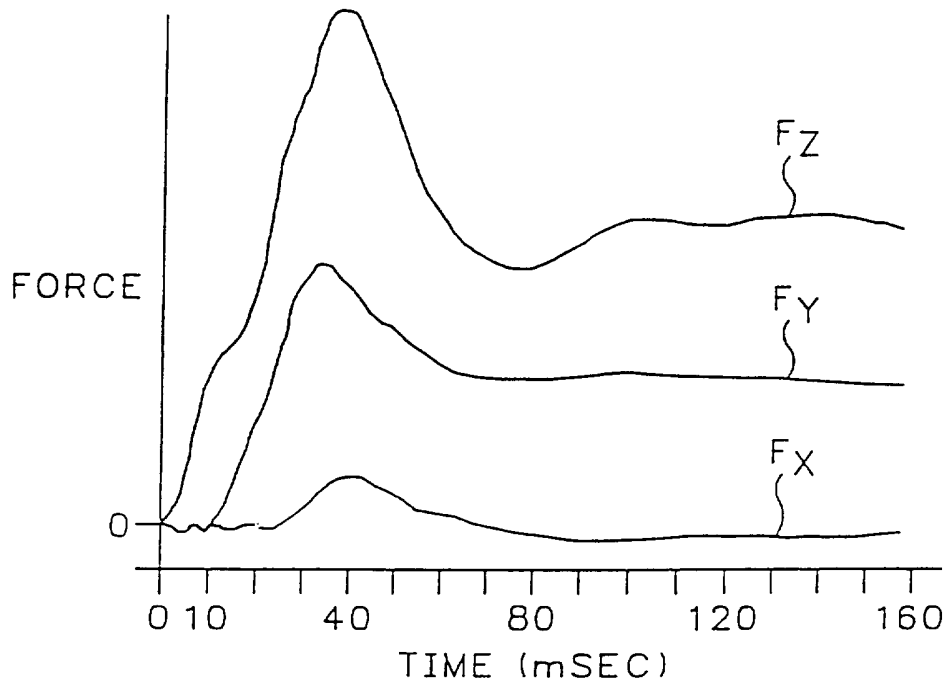

FIG. 7

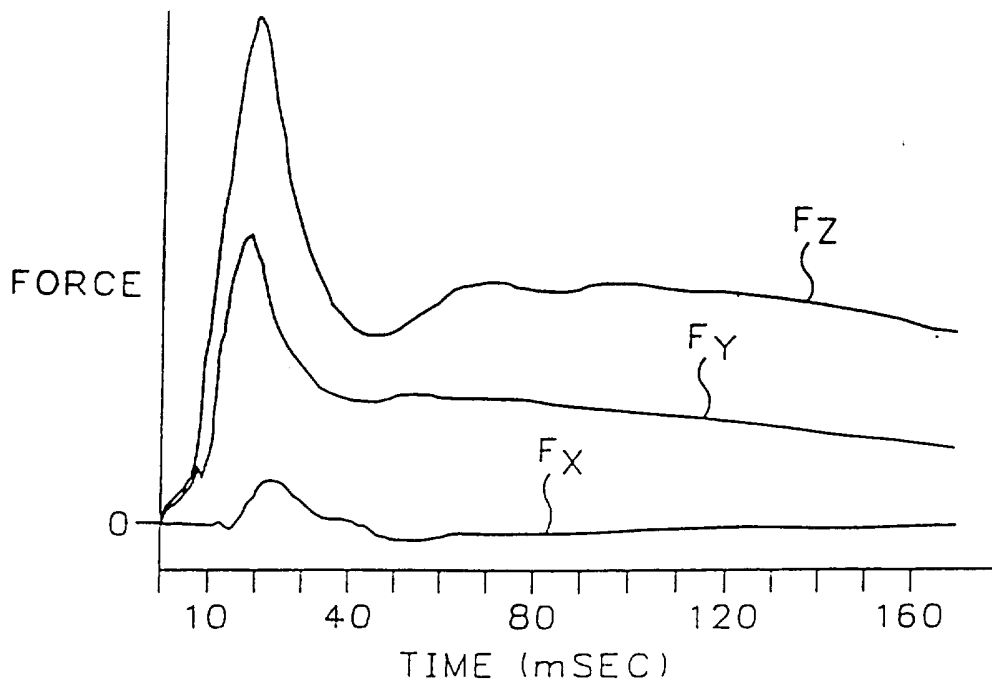

FIG. 8