

(19) **DANMARK**

(10) **DK/EP 3663592 T3**



Patent- og  
Varemærkestyrelsen

(12) **Oversættelse af  
europæisk patentskrift**

- 
- (51) Int.Cl.: **F 16 B 5/06 (2006.01)** **H 05 K 5/00 (2006.01)** **F 16 B 21/02 (2006.01)**
- (45) Oversættelsen bekendtgjort den: **2023-04-24**
- (80) Dato for Den Europæiske Patentmyndigheds bekendtgørelse om meddelelse af patentet: **2023-01-25**
- (86) Europæisk ansøgning nr.: **18210173.3**
- (86) Europæisk indleveringsdag: **2018-12-04**
- (87) Den europæiske ansøgnings publiceringsdag: **2020-06-10**
- (84) Designerede stater: **AL AT BE BG CH CY CZ DE DK EE ES FI FR GB GR HR HU IE IS IT LI LT LU LV MC MK MT NL NO PL PT RO RS SE SI SK SM TR**
- (73) Patenthaver: **Gustav Hensel GmbH & Co. KG, Gustav-Hensel-Strasse 6, 57368 Lennestadt, Tyskland**
- (72) Opfinder: **Baetz, Marcus, Im Bruch 11, 57399 Kirchhundem, Tyskland**
- (74) Fuldmægtig i Danmark: **Zacco Denmark A/S, Arne Jacobsens Allé 15, 2300 København S, Danmark**
- (54) Benævnelse: **Konnektorsystem**
- (56) Fremdragne publikationer:  
**EP-A1- 0 046 223**  
**DE-A1-102012 018 694**  
**FR-A3- 2 540 946**



The present invention relates to a connector system.

For many assembly tasks, in particular when it comes to connecting flat surface areas with one another, it is usually necessary to fall back on non-positive connecting means. For instance, when connecting housings, boards, area elements of a general kind, these are usually screwed together, interspersed with bolts, or glued in a final position, and the like.

A clamping connection for pipes is known from EP 0 046 223 A1, where a flange with a through-hole is arranged on the outer surface in the end area of pipe lengths. Two pipes correspondingly fitted together can be rotated such that the through-holes of opposing flanges are aligned with one another. As a result, a bolt can be inserted. This can be a screw bolt or a bolt with a cam-like eccentric expansion.

During rotation of the bolt about its longitudinal axis, the eccentric area comes to rest against the edge of a hole.

Connector systems for other components are known from DE 10 2012 018 694 A1 and FR 2 540 946 A3, where a rod-shaped connecting element is inserted in slots which are aligned with one another. Possibilities for a secure bracing of the components are not proposed. For many fields of application, the effectiveness of the connection is not sufficient.

The invention is based on the object to provide a connector system which can be easily produced, easily actuated, and effectively used for connecting in particular housings and other flat elements.

For the technical achievement of this object, a connector system with the features of claim 1 is proposed. Other advantages and features result from the sub-claims.

According to the invention, the connector system comprises two bearing blocks, each of which has an opening, and which can be fastened relative to a surface and positioned in such a way that the openings are aligned with one another. Such bearing blocks may be produced individually and comprise for instance fastening elements such as screw holes, spring pins, tongue-and-groove systems, and the like. Furthermore, the connector system comprises a connecting bolt which can be inserted in the openings aligned with one another to connect the bearing blocks. After the bearing blocks have been properly positioned, this connecting bolt can be inserted in the openings and latched there. In the connector system according to the invention, a matching pair consisting of a projection and a recess is formed on the connecting bolt, on the one hand, and on at least one opening, on the other hand. So for instance, a cam or a spring pin can be formed on the connecting bolt, and a groove in the opening. The very opposite may be the case, however, namely that a long groove in the connecting bolt accommodates a cam projecting into the opening. The connecting bolt can be inserted in only one rotational position, otherwise the projection would interfere.

The connecting bolt comprises an eccentrically designed head end which is formed by an expansion in a segment of a circle. A corresponding opening may also be formed in the bearing block by an eccentric expansion in a segment of a circle, so that both expansions cooperate with one another.

According to a proposal of the invention, the bearing blocks are connected with each other from the start. They may, for instance, be arranged on a base plate or be connected by other connecting means such as for example threaded rods and the like. The bearing blocks which have been so connected in a preparatory manner can now be directly equipped with the connecting bolts. If, for example, the bearing blocks are passed through openings of elements to be connected, the connection can be secured by inserting and rotating the connecting bolt. The connecting bolt can be rotated until it reaches a stop element which is provided in accordance with a proposal of the invention. Furthermore, it can be latched in a position in a latching element. In accordance with an advantageous proposal of the invention, the stop element and the latching element are designed integrally, in that for instance a projection is formed on one of the bearing blocks in the area of the opening, which

projection cooperates with a projection on the connecting bolt. Here, too, the opposite is possible, namely that a projection in the area of the bearing block engages with a latching groove on the connecting bolt.

5 According to a proposal of the invention in more concrete terms, the connecting bolt has a web-like projection, extending parallel to a longitudinal central axis of the connecting bolt. The projection does not extend over the entire length, but in such a way that the end areas of the connecting bolt remain clear. In this manner, they can be inserted in the openings without the projection interfering.

10 This projection on the connecting bolt can cooperate with the projection on the bearing block for the purpose of stopping and latching. Furthermore, the projection on the connecting bolt can be used as a stop element during insertion in the openings in order to limit the depth of insertion.

The projection cooperates with a groove in the opening of the bearing block in which the connecting bolt is inserted.

15 When the bearing blocks are passed through openings in parts to be connected, the openings project on one side in alignment with each other. The connecting bolt can be inserted and latched in these openings to establish the connection. According to an advantageous proposal of the invention, the bearing blocks are designed such that the connecting bolt is braced against a surface penetrated by at least one of the  
20 bearing blocks, when the connecting bolt is rotated while being appropriately inserted in the openings of the bearing blocks. That means that the surface projects into the area of the clear opening of the bearing block, so that bracing is achieved when rotating the connecting bolt, which may be flattened.

25 By the invention, an easily implementable connector system is provided, by which extended possibilities for connecting housings, flat elements and the like can be realised.

Other advantages and features of the invention can be gathered from the following description on the basis of the figures. In these figures:

Fig. 1 shows a perspective representation of an exemplary embodiment of a connector system according to the invention;

Fig. 2 shows a representation according to Fig. 1 in a different connecting position;

5 Fig. 3 shows a representation according to Fig. 2 from a different perspective;

Fig. 4 shows a representation according to Fig. 1 in an application position;

Fig. 5 is an enlarged detailed top view onto the connector according to Fig. 4; and

Fig. 6 shows a representation according to Fig. 4 in a connecting position;

10 In the figures, identical elements are identified by the same reference numerals.

Figures 1 through 3 show an exemplary embodiment of a connector system according to the invention.

The connector system 1 comprises a bearing block 2 and a bearing block 3. In the exemplary embodiment shown, the bearing blocks 2 and 3 are arranged on a base plate 4. The base plate 4 in the exemplary embodiment shown comprises fastening elements 5 in the form of spring hooks.

Bearing block 2 has opening 6, bearing block 3 has opening 7. As shown in the Figures, opening 7 is essentially perfectly circular. The same applies to opening 6 which, however, has an eccentric expansion in the front area of area 11.

20 Furthermore, the connector system comprises a connecting bolt 8 which has an expansion of bolt 10 in the area of its front face 9, resulting in an eccentricity. The expansion of bolt 10 runs in the expansion of opening 11. The expansion of the opening is not continuous in the exemplary embodiment shown, but implemented

only on the surface.

As shown in particular in Figure 3, a stop/latching cam 12 is arranged on the back side of bearing block 2. The spring web 13 of connecting bolt 8 runs up this block by running along run-up ramp 16 until it engages with latching groove 17.

- 5 The Figures show that the bolt cross section 18 is flattened. The spring web 13 is designed so long that it forms a rear stop edge 19, with which the bolt runs up against bearing block 3.

In the exemplary embodiment shown, the base plate 4 is designed so that the heights of the bearing blocks are adapted to a planned mounting position. The  
10 openings 6 and 7 are aligned, thereby providing a lead-in for connecting bolt 8.

It turns out that the connecting bolt 8 can only be inserted in bearing block 2 and guided through to bearing block 3 in the position shown in Figure 1, as spring web 13 runs in groove 14 of bearing block 2. The connecting bolt 8 can only be rotated in the insertion position shown in Figure 1. For this purpose, a corresponding tool, for  
15 instance a screw driver, can be inserted in the actuating slot 15. During rotation, the front edge of spring web 13 located in the area of bearing block 2 will run via run-up ramp 16 into latching groove 17 of the stop and latching cam 12, on the one hand, while the eccentric expansion 10 in the front face area of connecting bolt 8 will run into the eccentric expansion 11 in bearing block 2, on the other hand, until the  
20 latching position shown in Figures 2 and 3 has been reached.

Figures 4 through 6 show a possible application of the connector system according to the invention. In the exemplary embodiment shown, two housings 20 and 21 are to be connected with one another. For this purpose, their surfaces are lying on top of each other in connection area 22. The surfaces have suitable passages 24, so that  
25 the bearing blocks project from a housing 21 through the passages 24 into the inside of housing 20. The base plate 4 then rests against the inner surface of housing 21.

Now the connecting bolt 8 is inserted in the openings of the bearing blocks 2 and 3 projecting into housing 20. For this purpose, it initially has the position shown in

Figures 4 and 5, in which position the spring web 13 can be guided in groove 14.

Figures 5 and 6 show that opening 6 is partly covered by the wall of housing 20 in a lower bracing area 23. If now the connecting bolt 8 is actuated, for instance by inserting a screw driver in actuating slot 15 and rotating it, connecting bolt 8 will reach the position shown in Figure 6. Due to the eccentricity, the bolt is now braced against the inner surface of housing 20 in connecting area 23. This occurs over the entire length of the connecting bolt, so that a very good connection of the two housings 20 and 21 is achieved in the most simple manner.

The described exemplary embodiments only serve a better understanding and are not restrictive.

**Reference numerals**

	1	Connector system
	2	Bearing block
	3	Bearing block
5	4	Base plate
	5	Fastening element
	6	Opening
	7	Opening
	8	Connecting bolt
10	9	Front face
	10	Expansion of bolt
	11	Expansion of opening
	12	Stop/latching cam
	13	Spring web
15	14	Groove
	15	Actuating slot
	16	Run-up ramp
	17	Latching groove
	18	Bolt cross section
20	19	Stop edge
	20	Housing
	21	Housing
	22	Connecting area
	23	Bracing area
25	24	Passages

## Patentkrav

### 1. Konnektorsystem omfattende

5 mindst to lejubukke (2, 3), der hver især har en åbning (6,7) og kan fastgøres  
i forhold til en overflade og positioneres på en sådan måde, at åbningerne (6,  
7) flugter med hinanden,  
og en forbindelsesbolt (8), der forbindende lejubukkene (2, 3) kan indsættes i  
åbningerne (6, 7), der flugter med hinanden,  
10 hvor forbindelsesbolten (8) og mindst en åbning (6, 7) omfatter et til hinanden  
passende par af et fremspring og en udsparring, således at forbindelsesbolten  
(8) kun i en tilsigtet fordrejningsposition kan indføres i denne åbning (6, 7),  
hvor forbindelsesbolten (8) har et excentrisk hovedstykke, **kendetegnet ved,**  
**at** die excentrikken er dannet af en diameterudvidelse i et cirkelsegment.

15 **2.** Konnektorsystem ifølge krav 1, **kendetegnet ved, at** lejubukkene (2, 3) er  
forbundet med hinanden.

**3.** Konnektorsystem ifølge krav 2, **kendetegnet ved, at** lejubukkene (2, 3) er  
20 anbragt fritstående på en basisplade (4).

**4.** Konnektorsystem ifølge krav 3, **kendetegnet ved, at** basispladen (4) har  
mindst et fastgørelseselement (5).

25 **5.** Konnektorsystem ifølge et af de foregående krav, **kendetegnet ved,**  
**at** mindst en lejubuk (2) har et stopelement til begrænsning af forbindelsesbol-  
tens (8) drejebevægelse.

**6.** Konnektorsystem ifølge et af de foregående krav, **kendetegnet ved,**  
**at** mindst en lejubuk (2) har et indgrebselement, der arbejder sammen med  
30 forbindelsesbolten (8).

**7.** Konnektorsystem ifølge krav 5 og 6, **kendetegnet ved, at** stopelementet og  
indgrebselementet er udformet i ét stykke.

8. Konnektorsystem ifølge krav 7, **kendetegnet ved, at** der på mindst en lejebuk (2) er udformet et fremspring, der arbejder sammen med et fremspring på forbindelsesbolten (8).

5      9. Konnektorsystem ifølge et af de foregående krav, **kendetegnet ved, at** forbindelsesbolten (8) har et forbindelsesstykkelignende fremspring (13), der forløber parallelt med en langsgående midterakse af forbindelsesbolten (8).

10     10. Konnektorsystem ifølge krav 9, **kendetegnet ved, at** fremspringet (13) er udformet således, at det frigiver forbindelsesboltens (8) endeområder.

15     11. Konnektorsystem ifølge et af kravene 9 eller 10, **kendetegnet ved, at** fremspringet (13) med en forkant arbejder sammen med fremspringet på lejebukken (2, 3).

15     12. Konnektorsystem ifølge et af de foregående krav, **kendetegnet ved, at** mindst en lejebuk (2) i åbningens (6, 7) område har en excentrisk udvidelse i et cirkelsegment.

20     13. Konnektorsystem ifølge et af de foregående krav, **kendetegnet ved, at** forbindelsesbolten (8) spændes mod en overflade, som mindst en af lejebukkene (2, 3) rager igennem, ved drejning i en tilsigtet tilstand, hvor den er indsat i lejebukkenes (2, 3) åbninger (6, 7).

25

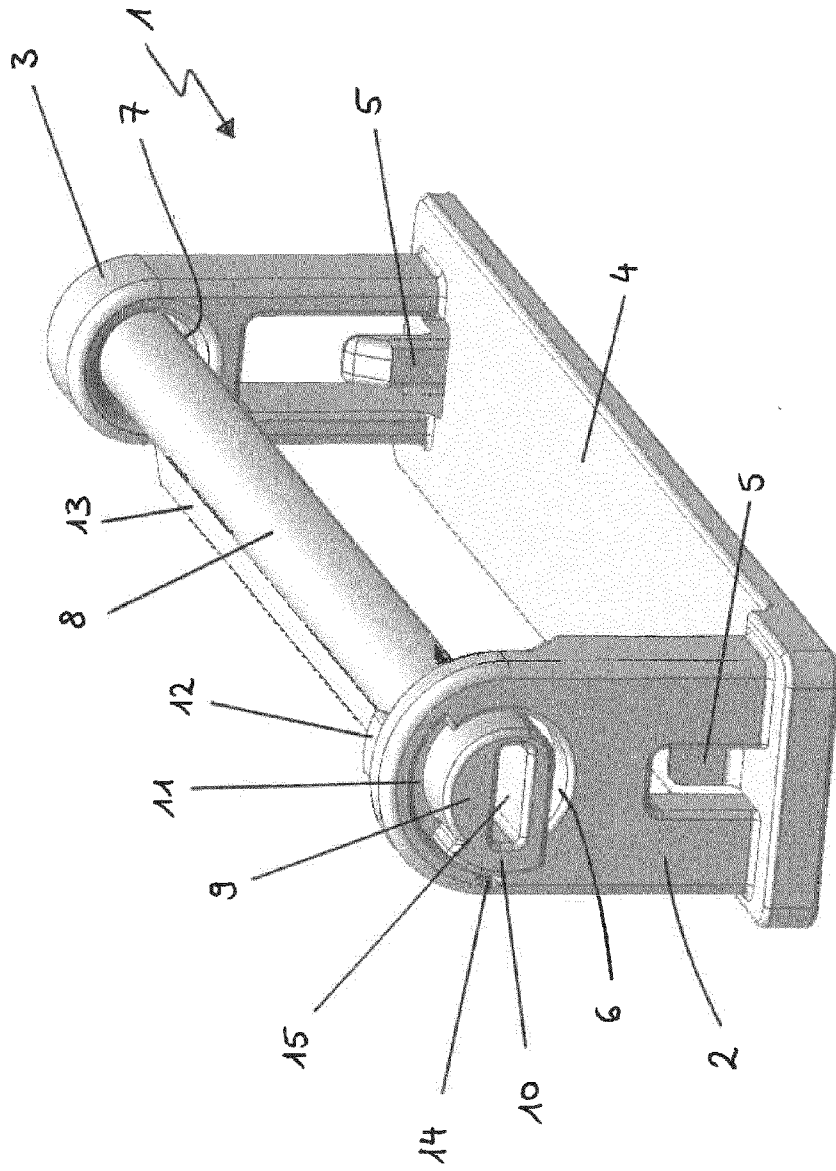
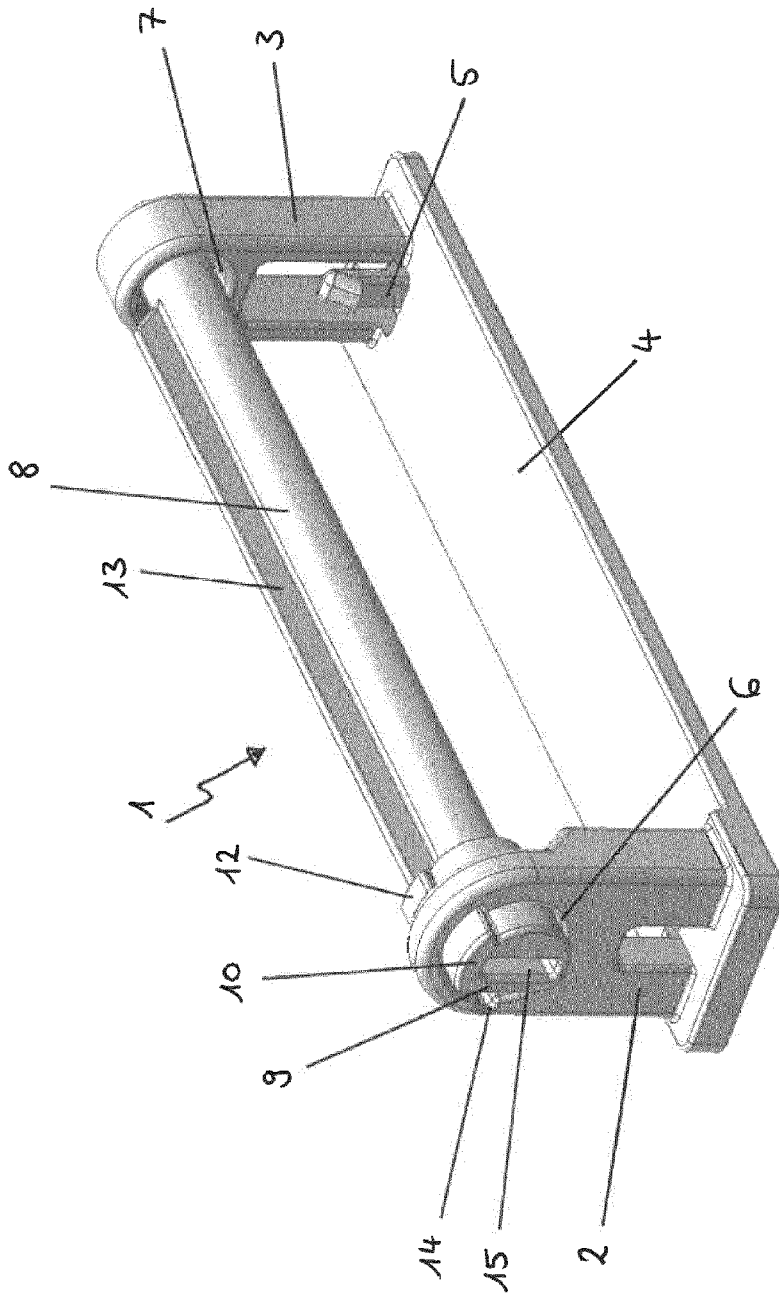

Fig. 1

Fig. 2





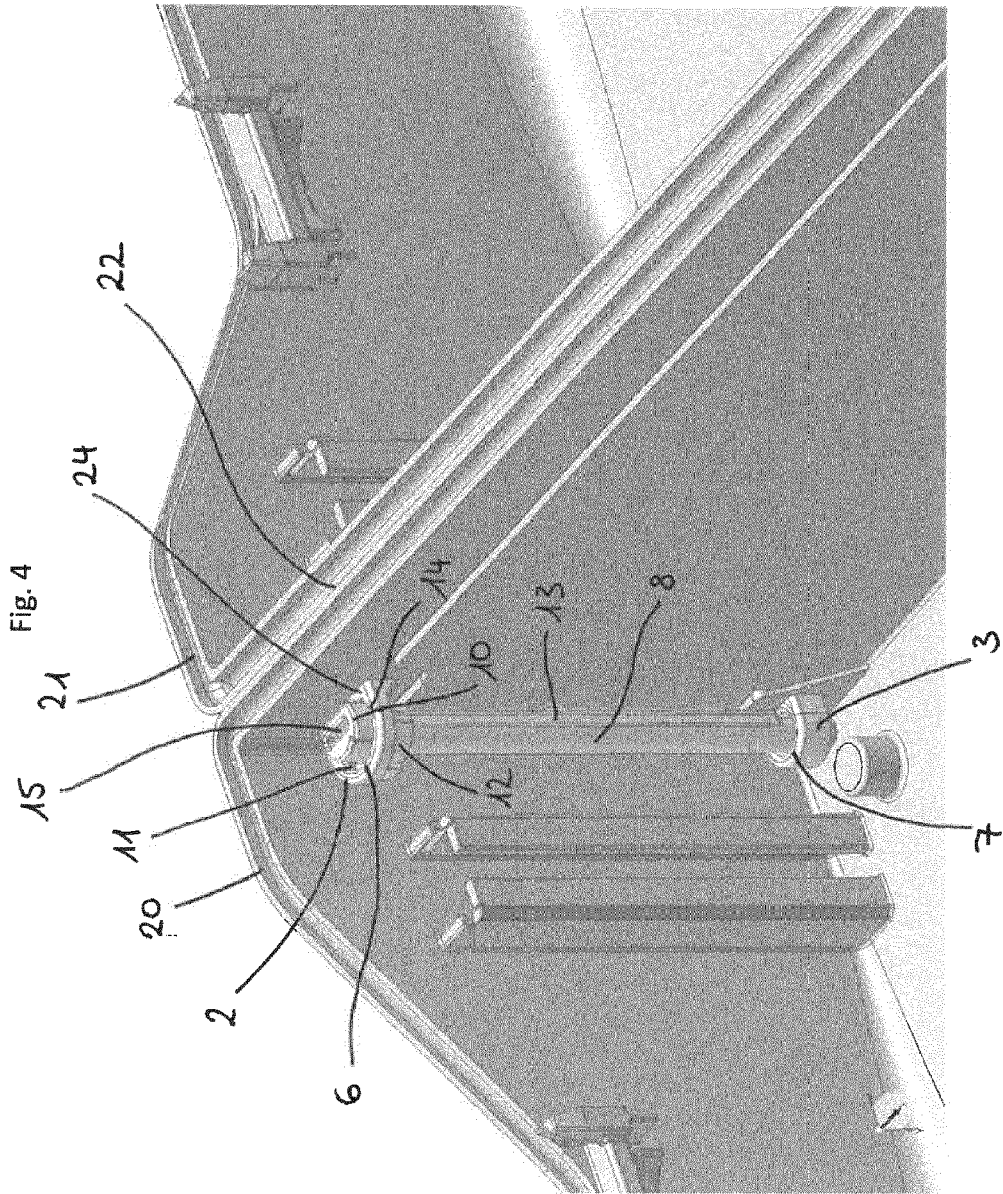

Fig. 5

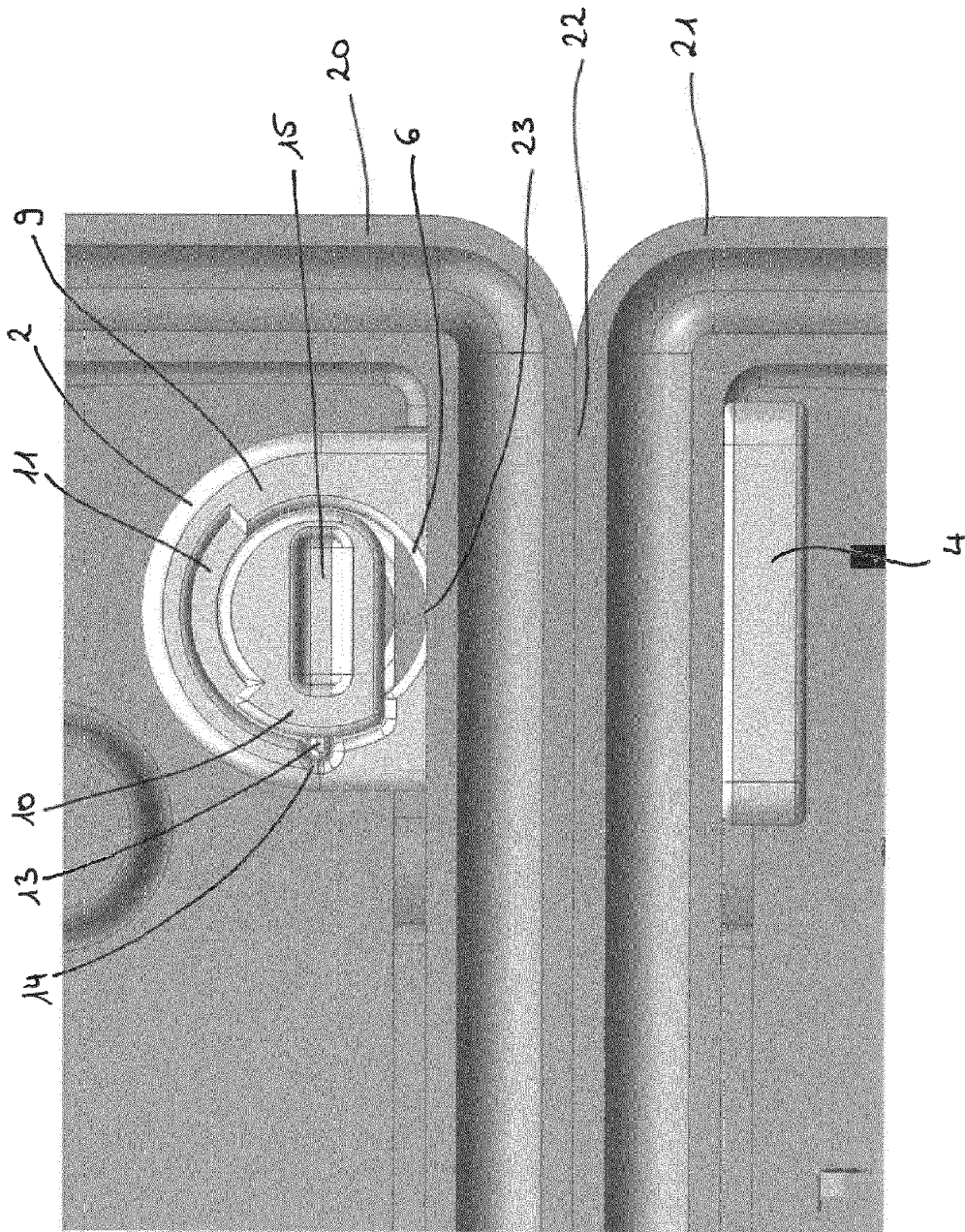

Fig. 6

