

J. Cole,

Steam-Boiler Furnace,

No. 5720.

Patented Aug. 22, 1848.

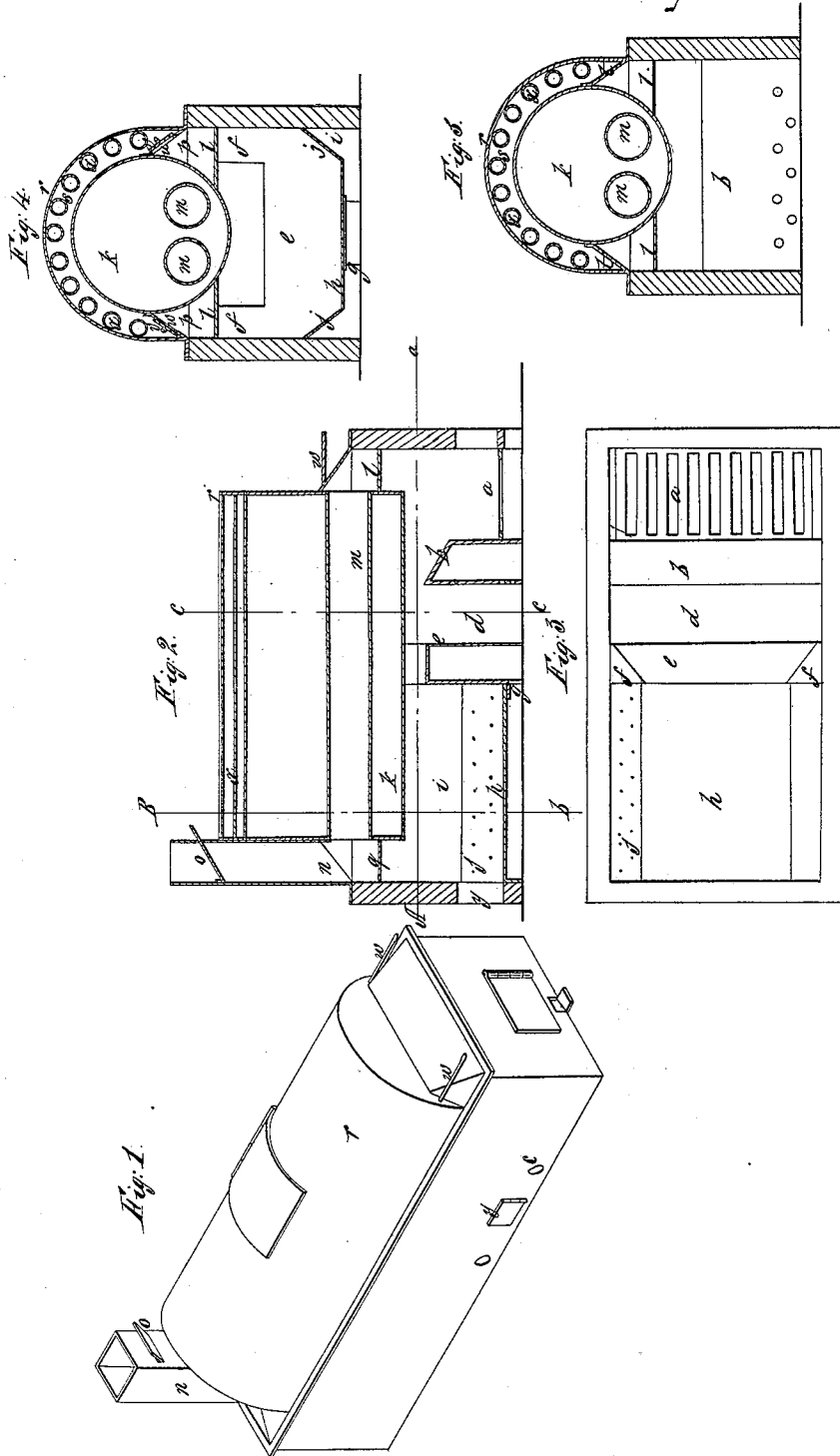

UNITED STATES PATENT OFFICE.

JAMES COLE, OF CINCINNATI, OHIO.

BOILER AND OTHER FURNACE.

Specification of Letters Patent No. 5,720, dated August 22, 1848.

To all whom it may concern:

Be it known that I, JAMES COLE, of Cincinnati, in the county of Hamilton and State of Ohio, have invented new and useful Improvements in Furnaces of Steam-Boilers, some of which improvements are also applicable to other purposes, and that the following is a full, clear, and exact description of the principle or character which distinguishes them from all other things before known and of the manner of making, constructing, and using the same, reference being had to the accompanying drawings, making part of this specification, in which—

Figure 1 is a perspective view of the furnace applied to a steam boiler; Fig. 2, a longitudinal vertical section; Fig. 3, a horizontal section taken at the line (Aa) of Fig. 2; and Figs. 4 and 5, cross vertical sections taken at the lines (Bb) and (Cc) of Fig. 2.

The same letters indicate like parts in all the figures.

By a series of careful experiments I have discovered that so long as the gaseous products of combustion contain either combustible gases or any other combustible matter in suspension at a temperature sufficiently high for combustion that such gases will move toward any part of a vessel in which atmospheric air is introduced. Whether this tendency be an attraction or affinity induced in the two bodies by the temperature to which they are heated I will not venture to decide, and therefore simply assert the fact as the result of experiment, and suggest the hypothesis that at a given temperature combustible matter has an affinity for oxygen, the supporter of combustion, for philosophical minds to investigate. The well known fact that combustible gases are generated in furnaces and escape with small particles of carbon in an unconsumed state (commonly called smoke) has led to numerous experiments to discover the best means of either preventing the production of such gases by a perfect combustion in the furnace or by the introduction of atmospheric air at or beyond the fire bridge to inflame all this combustible matter within the flues. By the latter of these general methods many important improvements have been made; but still furnaces waste much heat in this invisible manner. The discovery above pointed out of an attraction between combustible matter and the supporter of combustion together with the mode of introducing atmos-

pheric air beyond the fire bridge of furnaces to inflame the combustible gases constitute the bases of my leading improvements.

In my improved furnace the products of combustion from the fuel in the fire chamber in front pass over a hollow fire bridge and dive down into a chamber at the back thereof and reverberate from the back of this chamber toward the back of the fire bridge, and are then mingled with jets of atmospheric air heated within the fire bridge and discharged through apertures in the back, which admixture causes a union of the oxygen of the atmospheric air and the combustible matter making part of the products of combustion, thereby increasing the combustion and consequently the heat evolved. The products of combustion then pass over another fire bridge the throat of which is narrowed toward the back to retard in part their passage and retain them in the chamber sufficiently long to give out heat and prevent as much as possible their escape without the combustion of the combustible matter. From this throat the products of combustion pass into another reverberating chamber and are there reverberated downward to mingle the gases with jets of atmospheric air also heated within the second fire bridge and discharged therefrom under a false bottom, from which false bottom it is discharged in jets into the chamber through apertures in inclined plates at the sides to mingle with the products of combustion and inflame the combustible matter held in suspension, and at the same time to direct the heat against the bottom of the boiler and prevent the gases from accumulating in the corners. From this last chamber the products of combustion reverberate upward against the bottom of the boiler and run along the bottom of the boiler in a stratum above the lower current just described back to the front of the furnace where they enter the return flues in the boiler and thence pass to the chimney at the back. The upper part of the boiler is incased to form a hot air chamber, the bottom plate of which at each side extends over part of the furnace to the side plates thereof, and these bottom plates are provided each with an aperture or apertures governed by dampers to admit the heat to the chamber above the boiler the top of which is thus kept in a heated state, but at a temperature below that applied to the bottom—a temperature which can be readily

regulated to any degree required by the use of the dampers, and thereby prevent the steam from being surcharged or over heated; and within this chamber there is a series
5 of pipes through which the feeding water passes to be heated preparatory to being forced into the boiler.

The nature of the first part of my invention consists in causing the products of combustion to reverberate at the rear end of
10 the furnace and run back under the bottom of the boiler and over the current that passes from the grate or fire chamber to the back of the furnace, by carrying off the draft to the flues in the boiler (or to the chimney,
15 when such flues are not used) over or nearly over the grate or fire chamber when this is combined with the introduction of atmospheric air at any point or points back of the fire bridge to support the combustion of
20 combustible gases and other combustible matter held in suspension in the gaseous products of combustion, and thereby to induce the passage of the products of combustion toward the back of the furnace before
25 they reverberate and return to the front.

The second part of my invention consists in combining with the above method of causing the products of combustion to reverberate back from the back of the furnace to
30 the front thereof, the employment of reverberating chambers or sinks back of the hollow fire bridges provided with apertures for the discharge of heated atmospheric air to mingle with the products of combustion and
35 inflame the combustible gases or any other combustible matter held in suspension. And also in discharging the heated atmospheric air into the last of these chambers through apertures in inclined plates at the sides of
40 the chamber to direct the heat against the sides of the cylindrical bottom of the boiler.

The third part of my invention consists in narrowing the throat of the last of the series of fire bridges toward the back to
45 retard the passage of the products of combustion and retain them within the chamber or chambers forward of the last bridge, the better to inflame the combustible matters.

The fourth part of my invention consists in forming a hot air chamber over the top of the boiler and connecting with the furnace by means of holes governed by dampers
50 to heat the air therein and thus prevent the radiation of heat from the top of the boiler and to govern the temperature thereof.

And finally I claim heating the supply water by means of pipes combined with and placed in the hot air chamber, whereby the
60 heat employed to protect the top of the boiler heats the feed water.

In the accompanying drawings (*a*) represents the grate or fire chamber and (*b*) a fire bridge at the back thereof into which atmospheric air is introduced (from some

blowing apparatus or by the natural draft) through a hole (*c*); back of this bridge there is a chamber (*d*) into which the air, after being heated in the fire bridge, is discharged in jets through apertures in the back plate thereof to inflame the combustible matter
70 contained in the products of combustion, and after being thus inflamed all the products pass over another fire bridge (*e*) in the upper part of which a throat is formed by narrowing in the sides (*f, f*) to check in part
75 the passage of the gases and prevent their too rapid escape. This second fire bridge is also hollow to heat atmospheric air in like manner as in the first, which when thus heated escapes through holes (*g*) near the
80 bottom of the back plate under the false bottom (*h*) of a chamber (*i*) at the back, the false bottom toward the sides of the chamber being inclined as at (*j, j*) and pierced
85 with small holes for the discharge of the heated air to mingle with the gaseous products of combustion as they enter this chamber from the last of the series of fire bridges to consume the last remnants of combustible
90 matter. In the chamber last described the gaseous products of combustion reverberate upward by reason of the increased rarefaction, and the combustion of the last particles of carbon previously held in suspension, and
95 when thus reverberated they form a current along the bottom of the boiler (*k*) and pass back to the front, and mainly over two ledges (*l, l*) projecting one from each of the side plates of the furnace, giving out heat to the
100 sides and bottom of the boiler and at the front they turn up and enter the return flues (*m, m*) in the boiler and pass through them to the back end of the boiler and escape into the chimney (*n*) which is provided with a damper (*o*) for regulating the draft. The ledges (*l, l*) extend from the back of the last
105 fire bridge to and around the front end of the boiler and in width they reach from the sides of the furnace to the boiler and form
110 flues (*p, p*) along the sides of the boiler leading to the front end of the return flues. There is also another ledge (*q*) at the back end below the vertical chimney to prevent the products of combustion from entering
115 the chimney at this end and compels them to reverberate and run back to the front end of the return flues in the boiler. The upper part of the boiler is inclosed by a cover (*r*) that extends down on each side to the sides
120 of the furnace and forming a hot air chamber (*s*) all over the boiler, this chamber being inclosed on each side at the bottom by plates (*t, t*) that incline upward from the sides of the furnace to the boiler to give an
125 inclination to the heated products of combustion, and direct them toward the sides of the boiler. The passage of the products of combustion between the inclined bottom plates of this chamber, and the ledges (*l, l*) 130

will partly heat the air contained in this chamber, and thus in a great measure prevent the radiation of heat from the top of the boiler; but to give the means of heating the air in this chamber to a higher temperature there is a hole (*u*) made in each of the inclined bottom plates (*t, t*) and governed by a damper (*v*) the rod (*w*) of which extends out to, and through the front of the apparatus by means of which the temperature in the hot air chamber can be regulated at pleasure. Within the hot air chamber thus formed I place a series of pipes (*x*) connected together in the usual manner of making heaters for heating the feed water of steam boilers, and these feed pipes are in the usual manner connected with the boiler and feed pump (not represented in the drawings) and therefore the connections need not be described. The feed water passing through these pipes will be heated by the heated air in the hot air chamber, so that by this arrangement of the hot air chamber over the top of the boiler the heat heretofore wasted by radiation is saved and at the same time the feed water is heated preparatory to its introduction in the boiler; as there is no draft in this hot air chamber it will not require cleaning. Man holes (*y*) are provided in various parts to admit of cleaning the boiler, flues, and all other parts as may be desired.

It will be obvious from the foregoing that the number of hollow fire bridges and reverberating chambers between them into which jets of atmospheric air are introduced may be varied without changing the principle of my invention, and that the return flues in the boiler may be dispensed with by placing the chimney at the front end of the furnace, that the upper reverberated current, when it returns to the front end of the furnace, may be discharged directly into the chimney instead of passing through the return flues.

It will be seen on careful consideration that the first part of my invention may be employed without the other features, provided any provision be made for the introduction of atmospheric air at some point or points back of the fire bridge to supply oxygen for the combustion of the combustible matter evolved or carried off from the fuel, and thereby to induce the desired current

toward the back of the furnace before the reverberation takes place toward the return flues or chimney, and therefore I do not wish to confine myself to the use of the peculiar mode herein described of supplying heated air altogether I deem the one described to be the best. Fan blowers may be used in the usual manner for the introduction of the blast of air under the grate and in the hollow fire bridges. The improvements above described in the furnace may obviously be applied to stoves, ovens, and other purposes, although I deem their application to steam boilers by far the most important and have therefore described and represented them as thus applied; but by substituting an oven for the boiler it will be seen that the oven can be readily heated and managed, and so of the other purposes to which my improvements are applicable.

What I claim as my invention, and desire to secure by Letters Patent, is—

1. Making the aperture or apertures for the discharge of the products of combustion from the furnace into the return flues or chimneys, at the end where the grate or fire chamber is placed and over it or nearly so, substantially as described, when this is combined with the introduction of atmospheric air at any place or places back of the fire bridge, substantially as described, whereby the products of combustion are caused to move at first from the fire grate to the back, and then back again over the first current to the aperture through which they are discharged into the return flues or the chimney when return flues are not used, as fully described.

2. I claim the reverberating chambers and hollow fire bridges with the arrangement for the introduction of heated atmospheric air in combination with the method above claimed of causing the products of combustion to reverberate back to the front from the rear part of the furnace, substantially as described.

In testimony whereof I have hereunto set my hand this seventeenth day of September, A. D. 1847.

JAMES COLE.

Witnesses:

ALEX. PORTER BROWNE,
WM. H. BISHOP.