

No. 644, III.

Patented Feb. 27, 1900.

J. F. TAYLOR.
HARROW.

(Application filed Nov. 13, 1899.)

(No Model.)

Fig. 1.

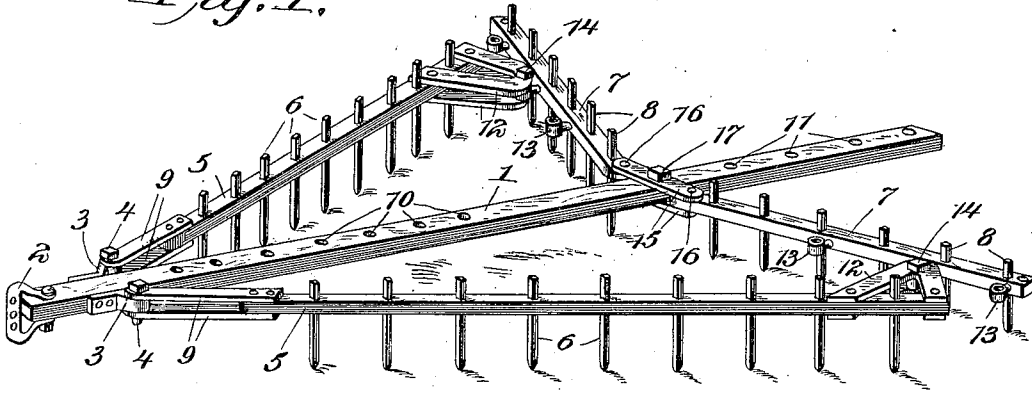

Fig. 2.

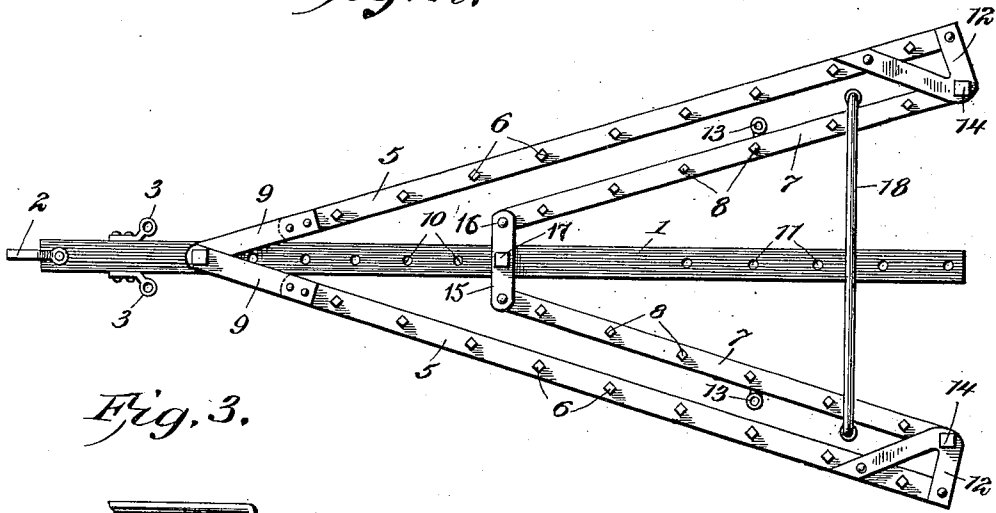
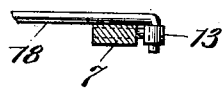

Fig. 3.



Witnesses
Howard D. Orr.
J. F. Riley

J. F. Taylor, Inventor.
By his Attorneys,
C. A. Snow & Co.

UNITED STATES PATENT OFFICE.

JAMES F. TAYLOR, OF GREENBRIER, ARKANSAS.

HARROW.

SPECIFICATION forming part of Letters Patent No. 644,111, dated February 27, 1900.

Application filed November 13, 1899. Serial No. 736,819. (No model.)

To all whom it may concern:

Be it known that I, JAMES F. TAYLOR, a citizen of the United States, residing at Greenbrier, in the county of Faulkner and State of Arkansas, have invented a new and useful Harrow, of which the following is a specification.

The invention relates to improvements in harrows.

The object of the present invention is to improve the construction of harrows and to provide a simple and comparatively inexpensive one adapted to be readily adjusted to span any desired depth of ground within its limits and to suit the character of the soil.

The invention consists in the construction and novel combination and arrangement of parts hereinafter fully described, illustrated in the accompanying drawings, and pointed out in the claims hereto appended.

In the drawings, Figure 1 is a perspective view of a harrow constructed in accordance with this invention. Fig. 2 is a plan view showing a different arrangement of the side beams from that shown in Fig. 1. Fig. 3 is a detail sectional view showing one end of the transverse rod in engagement with the adjacent rear side beam.

Like numerals of reference designate corresponding parts in all the figures of the drawings.

1 designates a central longitudinal draft-beam provided at its front end with a suitable clevis 2 and having eyes or loops 3 located at opposite sides of it, adjacent to its front end, for the reception of pivot-bolts or pintles 4, which connect a pair of front side beams 5 to the longitudinal beam, as clearly illustrated in Fig. 1 of the accompanying drawings. The side beams 5, which are provided with suitable harrow-teeth 6, are adjustably connected at their rear or outer ends to a pair of rear side beams 7, also provided with harrow-teeth 8, and the front ends of front side beams 6 are provided with upper and lower plates 9, arranged in pairs and adapted to receive the central draft-beam between them, as indicated in Fig. 2 of the accompanying drawings. The central draft-beam is provided with front and rear series of perforations 10 and 11, arranged at inter-

vals, as clearly illustrated in Fig. 1 of the accompanying drawings, and they permit the inner ends of the side beams to be secured to the central beam at different points. The side beams are provided at their inner ends with upper and lower substantially-V-shaped plates 12, arranged in pairs and extending inward from the front side beams and adapted to receive eyes 13 of the rear beams, and the said V-shaped plates are provided at their apexes with perforations for the reception of pins or bolts 14, which are adapted to engage the eyes 13, whereby the outer ends of the front and rear side beams are connected. The eyes 13 are located at different points on the rear side beams to permit the front side beams to be connected to the rear side beams at different points, whereby the harrow may be adjusted to span any desired breadth of ground within its limits.

The rear side beams are connected with the central draft-beam by means of a pair of transverse plates 15, located at the upper and lower faces of the central beam and projecting from opposite sides thereof and provided with central and end perforations. The end perforations receive the fastening devices 16 for securing the plates 15 to the rear beams 7, and the central perforations receive a pin or bolt 17, which also passes through one of the perforations of the draft-beam, whereby the rear side beams are secured to the same. The plates 15 may be secured at the rear portion of the central draft-beam when the harrow is arranged as illustrated in Fig. 1 of the accompanying drawings, or the bolt 17 may be engaged with one of the front series of perforations 10 when the parts are arranged as shown in Fig. 2.

When the front and rear side beams are arranged as illustrated in Fig. 2 of the accompanying drawings, they are parallel and are retained at the desired angle to the central draft-beam by means of a removable transverse rod 18, having its terminals bent downward at right angles and engaging the eyes 13. This rod may be engaged with different eyes, and it is adapted to be removed to permit the front and rear side beams of the harrow to be arranged as shown in Fig. 1. The front side beams are removable, and the rear

side beams and the transverse rod may be employed to arrange the parts for a one-horse harrow.

It will be seen that the harrow is exceedingly simple and inexpensive in construction, that it possesses great strength and durability, and that the side beams may be arranged at a different angle to the central beam, and the front and rear beams may be disposed in different positions with relation to each other to provide a harrow of the desired width and to arrange the teeth in the desired position to suit the character of the soil. It will also be apparent that the front side beams may be removed when it is desired to provide a one-horse harrow.

What is claimed is—

1. A harrow comprising a central longitudinal draft-beam, the front side beams hingedly connected at their inner ends to the longitudinal beam and capable of adjustment longitudinally thereof, and the rear side beams adjustably connected at their inner ends to the central beam and having their outer ends adjustably connected with the outer ends of the front side beams, substantially as described.

2. A harrow comprising a central longitu-

dinal draft-beam, front side beams hinged to the central beam and provided with harrow-teeth, rear side beams adjustably and hingedly connected at their inner ends to the central longitudinal beam, and adjustably connected at their outer portions to the outer portions of the front side beams, and a continuous rigid transverse rod adjustably and detachably interlocked with the rear side beams, substantially as described.

3. A harrow comprising a central longitudinal beam provided with perforations and having front loops located at opposite sides of its front portion, the front side beams hingedly connected with the beam and adapted to engage either the loops or perforations, and the rear side beams adjustably connected at their inner ends with the central beam and at their outer ends with the front side beam, substantially as described.

In testimony that I claim the foregoing as my own I have hereto affixed my signature in the presence of two witnesses.

JAMES F. TAYLOR.

Witnesses:

J. E. WOFFORD,
A. M. DICKENS.