



- (51) **International Patent Classification:**
A61M 37/00 (2006.01) A61B 17/22 (2006.01)
- (21) **International Application Number:**
PCT/US2014/022797
- (22) **International Filing Date:**
10 March 2014 (10.03.2014)
- (25) **Filing Language:** English
- (26) **Publication Language:** English
- (30) **Priority Data:**
61/781,750 14 March 2013 (14.03.2013) US
- (71) **Applicant:** EKOS CORPORATION [US/US]; 11911 North Creek Parkway South, Bothell, WA 98011 (US).
- (72) **Inventors:** KERSTEN, Jocelyn; 11416 102nd CT NE, Kirkland, WA 98033 (US). GENSTLER, Curtis; 17221 Butler Road, Snohomish, WA 98290 (US). WOLNIEWICZ, Raymond, M. III; 16508 NE 134th Place, Redmond, WA 98052 (US). HANSMANN, Douglas, R.; 5008 Rockaway Beach Road NE, Bainbridge Island, WA 98110 (US).
- (74) **Agent:** ALTMAN, Daniel, E.; Knobbe Martens Olson & Bear, LLP, 2040 Main Street, 14th Floor, Irvine, CA 92614 (US).

- (81) **Designated States** (unless otherwise indicated, for every kind of national protection available): AE, AG, AL, AM, AO, AT, AU, AZ, BA, BB, BG, BH, BN, BR, BW, BY, BZ, CA, CH, CL, CN, CO, CR, CU, CZ, DE, DK, DM, DO, DZ, EC, EE, EG, ES, FI, GB, GD, GE, GH, GM, GT, HN, HR, HU, ID, IL, IN, IR, IS, JP, KE, KG, KN, KP, KR, KZ, LA, LC, LK, LR, LS, LT, LU, LY, MA, MD, ME, MG, MK, MN, MW, MX, MY, MZ, NA, NG, NI, NO, NZ, OM, PA, PE, PG, PH, PL, PT, QA, RO, RS, RU, RW, SA, SC, SD, SE, SG, SK, SL, SM, ST, SV, SY, TH, TJ, TM, TN, TR, TT, TZ, UA, UG, US, UZ, VC, VN, ZA, ZM, ZW.
- (84) **Designated States** (unless otherwise indicated, for every kind of regional protection available): ARIPO (BW, GH, GM, KE, LR, LS, MW, MZ, NA, RW, SD, SL, SZ, TZ, UG, ZM, ZW), Eurasian (AM, AZ, BY, KG, KZ, RU, TJ, TM), European (AL, AT, BE, BG, CH, CY, CZ, DE, DK, EE, ES, FI, FR, GB, GR, HR, HU, IE, IS, IT, LT, LU, LV, MC, MK, MT, NL, NO, PL, PT, RO, RS, SE, SI, SK, SM, TR), OAPI (BF, BJ, CF, CG, CI, CM, GA, GN, GQ, GW, KM, ML, MR, NE, SN, TD, TG).

Published:
— with international search report (Art. 21(3))

(54) **Title:** METHOD AND APPARATUS FOR DRUG DELIVERY TO A TARGET SITE

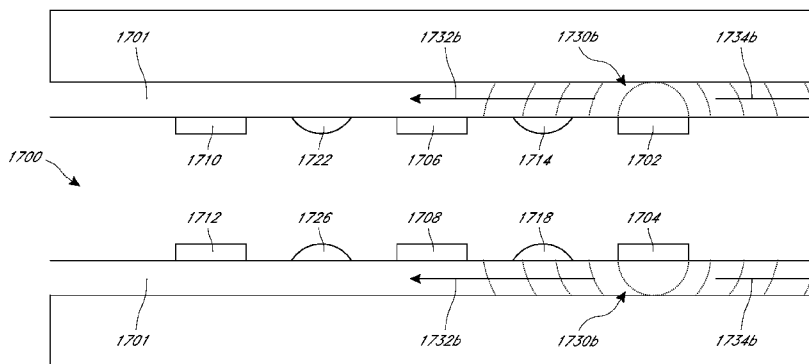

FIG. 17B

(57) **Abstract:** An ultrasound catheter with a lumen for fluid delivery and/or fluid evacuation, and ultrasound radiating elements is used for the delivery of therapeutic compounds to a target location. After the catheter is inserted into a cavity, a therapeutic compound can be delivered to the target location via selective activation of the ultrasound radiating elements. Selective activation of the ultrasound radiating elements can be used to cause fluid flow in a direction proximal and/or distal the catheter. Moreover, selective activating can be used to maintain fluid between certain of the ultrasound radiating elements.

WO 2014/159274 A1

METHOD AND APPARATUS FOR DRUG DELIVERY TO A TARGET SITE

PRIORITY INFORMATION

[0001] The present application claims priority to U.S. Provisional Application No. 61/781,750 filed March 14, 2013, the entire contents of which is hereby expressly incorporated by reference.

BACKGROUND OF THE INVENTION

Field of the Invention

[0002] The present invention relates to methods and apparatuses for increasing the efficacy of therapeutic compounds delivered to tissues affected by disease, and more specifically, to methods and apparatuses for increasing the efficacy of therapeutic compounds delivered to targeted tissue, such as brain tissue, using ultrasound.

Background of the Invention

[0003] A large number of Americans each year suffer from diseases affecting the brain and other parts of the body. Such diseases include cancer, Alzheimer's, Parkinson's Syndrome, as well as other illnesses. However, the efficacy of such treatments is significantly reduced as a result of physiological barriers. One such example of a physiological barrier is the blood-brain barrier which serves as a boundary between blood and fluid from the central nervous system. Such physiological barriers significantly reduce the ability of therapeutic compounds placed within the bloodstream to cross the barrier and effectively act upon targeted tissue. This is especially true for therapeutic compounds consisting of larger molecules. As a result, the physiological barrier significantly reduces the ability of therapeutic compounds delivered into the bloodstream to reach targeted tissue across the barrier thereby significantly reducing the possibility of effective treatment of the disease. As such, there is an interest in developing of targeted therapeutic compound delivery systems which can enhance the ability of these compounds to cross such physiological barriers.

[0004] In order to treat diseases affecting the brain and other parts of the body, some current methods deliver therapeutic compounds directly to areas affected by the disease. For example, with respect to the brain, some current methods deliver therapeutic compounds directly to affected tissue to bypass any complications arising as a result of the blood-brain barrier. It is particularly important, especially in sensitive areas

such as the brain, to increase efficacy of such compounds placed in the bloodstream by more directly targeting the affected tissue with the delivered drugs. This can reduce the need for higher concentrations of the compounds and reduce the amount any adverse effects on neighboring healthy tissue.

[0005] With respect to treatment of diseases affecting the brain, current methods and devices use various fluid infusion techniques under pressure, sometimes termed convection-enhanced delivery (CED), to conduct targeted therapeutic compound delivery to targeted brain tissue. These methods involve connecting a pump to a catheter to drive fluid containing a therapeutic compound into the targeted tissue. However, since these techniques require volumetric infusion into a closed vessel (i.e., the cranium), pressures within the closed vessel increase. In highly sensitive areas, such as the brain, there is a limit to the amount of pressure increase, and therefore the amount of infusion possible, before injuries are sustained as a result of stresses and strains caused by the increased pressures. As such, limits are placed on the amount of enhancement that can be achieved using current CED techniques. Additionally, current CED techniques have been shown to oftentimes not reach the targeted location. Furthermore, other complications arise which further reduce the efficacy of this treatment method such as fluid traveling back along the catheter and away from the targeted area (i.e., backflow).

[0006] As such, while CED therapies have shown promise, there is a general desire to continue to improve the methods and apparatuses involved with such therapy.

SUMMARY OF THE INVENTIONS

[0007] Methods of activating and sequencing ultrasound radiating elements are provided which increase the efficacy of therapeutic compounds delivered to targeted tissue. In accordance with these methods, embodiments of ultrasound catheters configured to implement the above methods are also included.

[0008] An embodiment of an ultrasound catheter for increasing the efficacy of therapeutic compounds delivered to targeted tissue comprises an elongate tubular body having a distal portion, a proximal portion, and a central lumen. The catheter further comprises a plurality of ultrasound radiating elements positioned within the tubular body. A plurality of ports are located on the distal portion of the elongate tubular body, and are configured to allow a fluid to flow through the ports.

[0009] In another embodiment an ultrasound catheter assembly includes an elongate tubular body having a distal portion and a proximal portion. The elongate

tubular body has material properties similar to that of standard external ventricular drainage (EVD) catheter. A lumen is formed within the elongate tubular body. The lumen includes a plurality of ports on the distal portion of the elongate tubular body configured to allow fluid to flow therethrough. An ultrasonic core is configured to be received within the lumen of the catheter. The ultrasonic core comprises a plurality of ultrasound radiating elements.

[0010] In another embodiment, an ultrasound catheter comprises an elongate tubular body having a distal portion and a proximal portion. A first drainage lumen is formed within the elongate tubular body. The drainage lumen includes a plurality of drainage ports on the distal portion of the elongate tubular body configured to allow fluid to flow therethrough. A delivery lumen is formed within the elongate tubular body. The delivery lumen includes a plurality of delivery ports on the distal portion of the elongate tubular body configured to allow fluid to flow therethrough. A plurality of ultrasound radiating elements are positioned within the elongate tubular body.

[0011] In one method of activating ultrasound radiating elements of the ultrasound catheters, activation of one or more ultrasound radiating elements is configured to increase permeability in targeted tissues thereby increasing the efficacy of a therapeutic compound. Additionally, such activation is configured to enhance mixing of the therapeutic compound via pressure waves and/or via cavitation.

[0012] In another method of activating and sequencing ultrasound radiating elements of the ultrasound catheters, activation of one or more ultrasound radiating elements is sequenced or synchronized with the timing of delivery of a therapeutic compound. This sequencing or synchronization is configured to create a flow pattern at the delivery site which can be controlled by modifying activation timing of certain ultrasound radiating elements. The flow pattern can be chosen to delivery therapeutic compounds directly to targeted tissue.

[0013] In yet another method of activating and sequencing ultrasound radiating elements of an ultrasound catheter, activation of one or more ultrasound radiating elements is sequenced or synchronized with the timing of delivery of multiple therapeutic compounds through multiple drainage or delivery ports of an ultrasound catheter. This sequencing or synchronization is configured create multiple flow patterns at the delivery site thereby allowing the multiple therapeutic compounds to be delivered to different targeted tissue.

BRIEF DESCRIPTION OF THE DRAWINGS

[0014] Exemplary embodiments of the method and apparatus for increasing the efficacy of therapeutic compounds delivered to targeted tissue are illustrated in the accompanying drawings, which are for illustrative purposes only. The drawings comprise the following figures, in which like numerals indicate like parts.

[0015] FIG. 1A is a schematic illustration of an ultrasonic catheter configured for insertion within the cranial cavity.

[0016] FIG. 1B is an enlarged detail view of the distal end of the ultrasonic catheter shown in FIG. 1A.

[0017] FIG. 1C is an enlarged detail view of the proximal end of the ultrasonic catheter shown in FIG. 1A.

[0018] FIG. 1D is a schematic illustration of a stylet that can be inserted into the ultrasonic catheter shown in FIG. 1A.

[0019] FIG. 1E is a schematic illustration of an ultrasonic core that can be inserted into the ultrasonic catheter shown in FIG. 1A.

[0020] FIG. 1F is a cross-sectional view taken through line 1F-1F of FIG. 1A.

[0021] FIG. 1G is a cross-sectional view of an ultrasonic catheter, according to an embodiment.

[0022] FIG. 1H is a cross-sectional view of an ultrasonic catheter, according to another embodiment.

[0023] FIG. 2A is a schematic illustration of an ultrasonic catheter with embedded wires.

[0024] FIG. 2B is an enlarged detail view of the distal end of the ultrasonic catheter shown in FIG. 2A.

[0025] FIG. 2C is an enlarged detail view of a medial portion of the ultrasonic catheter shown in FIG. 2A.

[0026] FIG. 2D is an enlarged detail view of the proximal end of the ultrasonic catheter shown in FIG. 2A.

[0027] FIG. 3 is a schematic illustration of an ultrasonic catheter partially inserted into the brain.

[0028] FIG. 4A is a schematic illustration of an ultrasonic catheter configured for insertion within the cranial cavity.

- [0029] FIG. 4B is a cross-sectional view taken through line J-J of FIG. 4A.
- [0030] FIG. 5A is a schematic illustration of an ultrasonic catheter configured for insertion within the cranial cavity, according to yet another embodiment
- [0031] FIG. 5B is a cross-sectional view taken through line H-H of FIG. 5A.
- [0032] FIG. 6A is a perspective view of a feature for receiving an ultrasonic element.
- [0033] FIG. 6B is a perspective view of another embodiment of a feature for receiving an ultrasonic element.
- [0034] FIG. 7A is a schematic illustration of an ultrasonic catheter with a coaxial drain port.
- [0035] FIG. 7B is an axial view of the ultrasonic catheter shown in FIG. 7A.
- [0036] FIG. 7C is a perspective view of the ultrasonic catheter of FIG. 7A.
- [0037] FIG. 8A is a schematic illustration of an ultrasonic catheter with drain ports proximal to the connector.
- [0038] FIG. 8B is a perspective view of the ultrasonic catheter of FIG. 8A.
- [0039] FIG. 9A is an exploded view of an ultrasonic catheter, according to an embodiment.
- [0040] FIG. 9B is a schematic illustration of the ultrasonic catheter shown in FIG. 9A.
- [0041] FIG. 9C is a cross-sectional view taken through line N-N of FIG. 9B.
- [0042] FIG. 9D is an enlarged detail view of the distal end of the ultrasonic catheter shown in FIG. 9B.
- [0043] FIG. 9E is a cross-sectional view taken through line M-M of FIG. 9B.
- [0044] FIG. 9F is a perspective view of the ultrasonic catheter shown in FIG. 9B
- [0045] FIG. 10A is an exploded view of an ultrasonic catheter, according to another embodiment.
- [0046] FIG. 10B is a schematic illustration of the ultrasonic catheter shown in FIG. 10A.
- [0047] FIG. 10C is a cross-sectional view taken through line P-P of FIG. 10B.
- [0048] FIG. 10D is a perspective view of the spiral extrusion shown in FIG. 10A.

[0049] FIG. 11A is a schematic view of a drain, according to one embodiment.

[0050] FIG. 11B is a cross-sectional view taken through line Q-Q of FIG. 11A.

[0051] FIG. 11C is a perspective view of the drain shown in FIG. 11A.

[0052] FIG. 11D is a schematic view of an ultrasonic core, according to one embodiment.

[0053] FIG. 11E is a perspective view of the ultrasonic core shown in FIG. 11D.

[0054] FIG. 11F is a perspective view of a catheter assembly, according to one embodiment.

[0055] FIG. 11G is a schematic view of the catheter assembly shown in FIG. 11F.

[0056] FIG. 11H is an enlarged detail view of the distal end of the drain shown in FIG. 11A.

[0057] FIG. 11I is an enlarged detail view of the distal end of the ultrasonic core shown in FIG. 11D.

[0058] FIG. 12A is a schematic view of an ultrasonic core wire, according to one embodiment.

[0059] FIG. 12B is a perspective view of an ultrasonic core wire with ultrasonic transducers affixed thereto.

[0060] FIG. 12C is a perspective view of an ultrasonic core wire with a polyimide shell surrounding ultrasonic transducers.

[0061] FIG. 13 is a schematic illustration of an ultrasonic element within a fluid-filled chamber, according to one embodiment.

[0062] FIG. 14 is a block diagram of a feedback control system for use with an ultrasonic catheter.

[0063] FIG. 15 is a table listing certain features of various embodiments of an ultrasonic catheter.

[0064] FIG. 16A is a perspective view of an ultrasonic catheter, according to another embodiment.

[0065] FIGS. 16B-D are enlarged detail views of the distal portion of the ultrasonic catheter shown in FIG. 16A. is a schematic illustration of the ultrasonic catheter shown in FIG. 10A.

[0066] FIG. 16E is a schematic illustration of wires and ultrasonic radiating members embedded within the ultrasonic catheter shown in FIG. 16A.

[0067] FIG. 17A-D illustrates potential sequencing and synchronization of activation of ultrasonic radiating elements within an ultrasound catheter.

[0068] FIG. 18A illustrates a cross section of an ultrasound assembly having a chamber between an ultrasound transducer and an external surface of an elongated body.

[0069] FIG. 18B illustrates a cross section along line "18B" of FIG. 18A.

[0070] FIG. 18C illustrates a cross section along line "18C" of FIG. 18C.

DETAILED DESCRIPTION OF THE PREFERRED EMBODIMENTS

[0071] As set forth above, methods and apparatuses have been developed that increase the efficacy of therapeutic compounds or physician specified fluids delivered to targeted tissue using ultrasonic energy in conjunction with the therapeutic compound. Disclosed herein are several exemplary embodiments of ultrasonic catheters that can be used to enhance the efficacy of therapeutic compounds at a treatment site within a patient's body. Also disclosed are exemplary methods for using such catheters. For example, as discussed in greater detail below, the ultrasonic catheters disclosed herein can be used to deliver a therapeutic compound to a blood clot in the brain or other part of the body, allowing at least a portion of the blood clot to be dissolved and/or removed, thereby reducing damage to brain or other bodily tissue. As an additional example, the ultrasonic catheters disclosed herein can be used to deliver therapeutic compounds, such as cancer drugs and treatments, alkylating agents, antimetabolites, and anti-tumor antibiotics, to tumors and/or other drugs used to treat conditions in the brain or other portions of the body. Although the embodiments described herein are described primarily in connection with intracranial use, it should be understood that the embodiments disclosed herein are also suitable for intraventricular use or use in other parts of the body in other applications. Accordingly, the term "intracranial use" can also include intraventricular use.

[0072] As used herein, the term "therapeutic compound" refers broadly, without limitation, and in addition to its ordinary meaning, to a drug, medicament,

dissolution compound, genetic material or any other substance capable of effecting physiological functions. Additionally, a mixture including substances such as these is also encompassed within this definition of "therapeutic compound". Examples of therapeutic compounds include thrombolytic compounds, anti-thrombosis compounds, and other compounds used in the treatment of vascular occlusions and/or blood clots, including compounds intended to prevent or reduce clot formation, neuroprotective agents, anti-apoptotic agents, and neurotoxin scavenging agents. Exemplary therapeutic compounds include, but are not limited to, heparin, urokinase, streptokinase, tPA, rtPA, BB-10153 (manufactured by British Biotech, Oxford, UK), plasmin, IIb/IIIa inhibitors, desmoteplase, caffeineol, deferoxamine, and factor VIIa. Other examples of therapeutic compounds include cancer drugs and treatments, alkylating agents, antimetabolites, and anti-tumor antibiotics and any other drug used to treat any ailment or disease such as for example, cancer (e.g., brain cancer, lung cancer, skin cancer, etc.), Parkinson's Syndrome, Alzheimer, and other such ailments or diseases. Other examples include cancer and/or oncological drugs, e.g., sonodynamic drugs, used to treat tumors and gliomas in the brain or other parts of the body. The methods and apparatus described above can be used to treat tumors and gliomas.

[0073] As used herein, the terms "ultrasonic energy", "ultrasound" and "ultrasonic" refer broadly, without limitation, and in addition to their ordinary meaning, to mechanical energy transferred through longitudinal pressure or compression waves. Ultrasonic energy can be emitted as continuous or pulsed waves, depending on the parameters of a particular application. Additionally, ultrasonic energy can be emitted in waveforms having various shapes, such as sinusoidal waves, triangle waves, square waves, or other wave forms. Ultrasonic energy includes sound waves. In certain embodiments, the ultrasonic energy referred to herein has a frequency between about 20 kHz and about 20 MHz. For example, in one embodiment, the ultrasonic energy has a frequency between about 500 kHz and about 20 MHz. In another embodiment, the ultrasonic energy has a frequency between about 1 MHz and about 3 MHz. In yet another embodiment, the ultrasonic energy has a frequency of about 2 MHz. In certain embodiments described herein, the average acoustic power of the ultrasonic energy is between about 0.01 watts and 300 watts. In one embodiment, the average acoustic power is about 15 watts.

[0074] As used herein, the term "ultrasound radiating element" or "ultrasound or ultrasonic element" refers broadly, without limitation, and in addition to its ordinary meaning, to any apparatus capable of producing ultrasonic energy. An ultrasonic transducer, which converts electrical energy into ultrasonic energy, is an example of an ultrasound radiating element. An exemplary ultrasonic transducer capable of generating ultrasonic energy from electrical energy is a piezoelectric ceramic oscillator. Piezoelectric ceramics typically comprise a crystalline material, such as quartz, that changes shape when an electrical current is applied to the material. This change in shape, made oscillatory by an oscillating driving signal, creates ultrasonic sound waves. In other embodiments, ultrasonic energy can be generated by an ultrasonic transducer that is remote from the ultrasound radiating element, and the ultrasonic energy can be transmitted, via, for example, a wire that is coupled to the ultrasound radiating element. In such embodiments, a "transverse wave" can be generated along the wire. As used herein is a wave propagated along the wire in which the direction of the disturbance at each point of the medium is perpendicular to the wave vector. Some embodiments, such as embodiments incorporating a wire coupled to an ultrasound radiating element for example, are capable of generating transverse waves. See e.g., U.S. Patent Nos. 6,866,670, 6,660,013 and 6,652,547, the entirety of which are hereby incorporated by reference herein. Other embodiments without the wire can also generate transverse waves along the body of the catheter.

[0075] In certain applications, the ultrasonic energy itself provides a therapeutic effect to the patient. Examples of such therapeutic effects include blood clot disruption; promoting temporary or permanent physiological changes in intracellular or intercellular structures; rupturing micro-balloons or micro-bubbles for therapeutic compound delivery; and increasing the permeability of the targeted cells. Increasing the permeability of the targeted cells can thereby enhance the efficacy of therapeutic compounds on those targeted cells. Further information about such methods can be found in U.S. Pat. Nos. 5,261,291 and 5,431,663.

[0076] FIGS. 1A to 1C and FIG. 1F schematically illustrate one arrangement of an ultrasonic catheter 10 that can be used to increase the efficacy of therapeutic compounds delivered to targeted tissue. FIG. 1B shows an enlarged detail view of a distal portion 12 of the catheter 10 and FIG. 1C illustrates an enlarged detail view of a proximal portion 14 of the catheter 10. In the illustrated arrangement, the ultrasonic

catheter 10 generally includes a multi-component, elongate flexible tubular body 16 having a proximal region 14 and a distal region 12. The tubular body 16 includes a flexible energy delivery section 18 located in the distal region 12. Within the distal region 12 are located a plurality of holes 20, through which fluid may flow into or out of a central lumen 22 (FIG. 1F) that extends though the catheter 10. Although the drainage holes 20 are shown as circular, the shape of the holes may be varied. For instance, the drainage holes may be oval, polygonal, or irregular. FIGS. 1G and 1H illustrate modified embodiments of the catheter which include separate lumens for fluid delivery and for fluid evacuation.

[0077] The catheter 10 defines the hollow lumen 22 which allows for the free flow of liquids between the drainage holes 20 and the proximal port 24. For instance, blood may flow from an area external to the ultrasonic catheter through the drainage holes 20 and into the lumen 22. The blood may then flow proximally in the lumen 22 towards the proximal region 14 of the ultrasonic catheter, where it may be collected via the drainage kit. In certain embodiments, any number of therapeutic compounds may be introduced into the ultrasonic catheter through the proximal end 14. The compounds, which may be dissolved or suspended within a liquid carrier, may flow through the lumen 22 and towards the distal end 12 of the ultrasonic catheter, ultimately exiting the catheter through drainage holes 20 and entering a treatment site.

[0078] In certain embodiments, negative pressure may be applied to the lumen 22 of the catheter to facilitate the flow of blood from the drainage holes 20 towards the proximal end 14. In other embodiments, no external pressure is applied, and the conditions present at the treatment site are sufficient to cause the blood to flow proximally through the lumen 22. In some embodiments, a positive pressure may be applied to the lumen 22 of the catheter 10 in order for therapeutic compounds or other liquids to pass distally through the lumen 22 towards the drainage holes 20. In other embodiments, no external pressure is applied, and the liquid is permitted to independently flow distally and exit the drainage ports 20.

[0079] The tubular body 16 and other components of the catheter 10 can be manufactured in accordance with a variety of techniques known to an ordinarily skilled artisan. Suitable materials and dimensions can be readily selected based on the natural and anatomical dimensions of the treatment site and on the desired access site. In addition, the surface of the catheter 10 can be coated with an antimicrobial material, such

as silver or a silver based compound. In certain embodiments, the catheter may be biocompatible for use in the brain or other organs and tissue for up to 7 days, for up to 15 days, up to 29 days, or for up to 30 days. In one arrangement, the catheter can be coated with a hydrophilic material.

[0080] In some embodiments, the tubular body 16 can be between about 23 and 29 centimeters in length. In certain arrangements, the lumen 22 has a minimum inner diameter of about 2 millimeters and the catheter body has a maximum outer diameter of about 6 mm.

[0081] In one particular embodiment, the tubular body 16 has material properties similar to that of standard external ventricular drainage (EVD) catheters. For example, the tubular body can be formed of radiopaque polyurethane or silicone, which can be provided with antimicrobial features. In such embodiments, the catheter 10 by itself may not have sufficient flexibility, hoop strength, kink resistance, rigidity and structural support to push the energy delivery section 18 through an opening in the skull, organ, or other tissue and then, in turn, to a treatment site (e.g., one of the ventricles). Accordingly, the catheter 10 can be used in combination with a stylet 26 (FIG. 1D), which can be positioned within the tubular body 10. In one embodiment for use in brain tissue, the device is configured to be compatible with Neuronavigation systems by easily accommodating the Neuronavigation system stylet. The stylet 26 can provide additional kink resistance, rigidity and structural support to the catheter 10 such that it can be advanced through the patients' brain tissue to the target site. In certain embodiments, the stylet 26 can be configured to be used in combination with a standard image guided EVD placement system. As described below, after placement, the stylet 26 can then be removed to allow drainage through the tubular body 16. In a modified arrangement, the tubular body 16 can be reinforced by braiding, mesh or other constructions to provide increased kink resistance and ability to be pushed with or without a stylet. In other embodiments, the device can be configured to be compatible with other navigation systems for use in other parts of the body.

[0082] In one embodiment, the tubular body energy delivery section 18 can comprise a material that is thinner than the material comprising the tubular body proximal region 14. In another exemplary embodiment, the tubular body energy delivery section 18 comprises a material that has a greater acoustic transparency than the material comprising the tubular body proximal region 14. In certain embodiments, the energy delivery section

18 comprises the same material or a material of the same thickness as the proximal region 14.

[0083] FIG. 1C shows an enlarged detail view of the proximal portion 14 of the ultrasonic catheter 10. The proximal portion 14 includes a connector 28. In the embodiment shown, the connector 28 comprises a series of annular rings 30 aligned in parallel. The connector 28 permits the catheter 10 to be joined to a drainage kit. For example, in one arrangement, the connector 28 is configured to connect to a standard EVD drainage kit that can include an attachment fitting that slides over the connector 28 or can include a buckle or joint that is fastened around connector 28. Specific length and configuration of the connector 28 can vary according to the needs of the particular application, and to facilitate connection with various drainage kits. Additionally, the number of annular rings 30 may vary in certain embodiments.

[0084] In the illustrated arrangement of FIGS. 1A-D and 1F, the catheter 10 can be use in combination with an inner core 32 (FIG. 1E) which can be inserted into the lumen 22 after the stylet 26 has been removed to deliver ultrasound energy to the target site. The core 32 can include proximal hub 34 fitted on one end of the inner core 32 proximal region. One or more ultrasound radiating members 36 are positioned within a distal region of the core and are coupled by wires 38 to the proximal hub 34. In some embodiments, the inner core 32 can be inserted into the lumen 22 and/or along a side of the catheter 10. In yet another arrangement, the core 32 can be inserted into the lumen 22 with the distal end including the ultrasound radiating members extending outside one of the holes positioned on the distal region of the catheter 10.

[0085] In other embodiments, the catheter 10 can include separate lumens for drainage and for drug delivery. FIGS. 1G and 1H show cross-sectional views of two embodiments of a catheter with multiple lumens. With reference to FIG. 1G, a fluid-delivery lumen 23 is located within the wall of the catheter 10, between the outer surface and the inner lumen 22, which may be used for fluid evacuation. In other embodiments, a plurality of fluid-delivery lumens 23 may be arranged within the catheter 10. Although shown as substantially circular in cross-section, any number of shapes may be employed to provide for optimal fluid flow through the fluid-delivery lumen 23. With reference to FIG. 1H, a separate fluid-delivery lumen 23 is located within a separate tube running longitudinally within the inner lumen 22. In certain embodiments, a plurality of fluid-delivery lumens 23 may be arranged within inner lumen 22. The size of fluid-delivery

lumen 23 may be small enough so as to not interfere with the function of inner lumen 23 in evacuating fluid from the treatment site.

[0086] These separate lumens connect drainage and drug delivery holes positioned generally at the distal end of the catheter with drug delivery and drainage ports positioned at the proximal end of the catheter. In one embodiment, the device can include separate lumens for the drug and drain delivery such that the holes and ports for drug delivery and drainage are separated from each other. In some embodiments, the device can include multiple lumens for delivery of multiple drug types and/or multiple drug concentrations. The multiple drug lumens can also be used to target drug delivery along different lengths of the catheter. In some embodiments, the treatment zone (defined as the distance between the distal most and proximal most ultrasound transducer) can be about 1 to 4 cm. In other embodiments, the treatment zone may extend as far as 10 cm. The drug and drain ports can include luer type fittings. The ultrasound transducers can be positioned near or between the drain and drug delivery holes.

[0087] FIGS. 2A-D are schematic illustrations of an ultrasonic catheter according to another embodiment. The catheter 10 contains components similar to that shown in FIGS. 1A-C and FIG. 1F-H. However, in this embodiment, includes wires 38 embedded within the wall of the tube. As will be explained below, the wires can activate and control ultrasonic radiating elements located within the distal region 12 of the catheter 10. Additionally, the catheter 10 may include thermocouples for monitoring temperature of the treatment zone, the catheter, or surrounding areas. In some embodiments, each ultrasound radiating element is associated with a temperature sensor that monitors the temperature of the ultrasound radiating element. In other embodiments, the ultrasound radiating element itself is also a temperature sensor and can provide temperature feedback. In certain embodiments, one or more pressure sensors are also positioned to monitor pressure of the treatment site or of the liquid within the lumen of the catheter.

[0088] In the embodiment shown, the wires 38 are bundled and embedded within the wall of the tubular body 16. In other embodiments, the wires may not be bundled, but may, for example, each be spaced apart from one another. Additionally, in certain embodiments the wires may not be embedded within the wall of the tubular body 16, but may rather run within the lumen 22. The wires 38 may include protective and/or insulative coating.

[0089] The wires may be advantageously configured such that they can withstand tension applied to the catheter. For example, the wires may be able to withstand at least 3 pounds of tension. In other embodiments, the wires may be able to withstand at least 3.6 pounds, at least 4 pounds, or at least 4.5 pounds of tension.

[0090] The wires may also be configured such that they increase the stiffness of the tubular body 16 as little as possible. The flexibility of the tubular body 16 facilitates the introduction of the catheter 10 into body cavities such as the cranial cavity. It may therefore be advantageous to select wires that only minimally contribute to the stiffness of the catheter. The wires chosen may be between 30 and 48 gauge. In other embodiments, the wires may be between 33 and 45 gauge, between 36 and 42 gauge, or between 38 and 40 gauge. The number of wires within the catheter is determined by the number of elements and thermocouples in a particular device.

[0091] In certain embodiments, the drainage holes 20 include radii on the outside of the holes, as can be seen in FIG. 2B. Applying a larger external radius to each drainage hole may improve the flow of blood into the drainage holes 20 and through the lumen of the catheter and may reduce damage to brain tissue or other tissue during insertion and withdrawal. Although the drainage holes 20 are depicted as arranged in regular rows, the pattern may vary considerably. The length of the region in which the holes are located may be between 2 and 4 cm. In certain embodiments, the length may be between 2.5 and 3.5 cm, or the length may be about 3 cm.

[0092] In the embodiment shown, the annular rings 30 located within in the proximal region 14 of the catheter 10 may be connected to the wires 38. In certain embodiments, a wire may be soldered to each annular ring 30. An electrical contact may then be exposed on the outer diameter of the annular ring 30 to provide for an electrical connection to an individual wire. By virtue of this design, each wire, and therefore each thermocouple or element, may be addressed independently. In alternative embodiments, two or more wires may be soldered to an annular ring, thereby creating a single electrical connection. In other embodiments, the wires may meet electrical contacts at other points within the catheter 10. Alternatively, the wires may pass through the wall of the tubular body 16 and connect directly to external apparatuses.

[0093] FIG. 3 is a schematic illustration of an ultrasonic catheter partially inserted into the brain. The catheter 10 may be positioned against the external surface of the skull, with the distal portion inserted through bore 40. The bore 40 creates an access

path through the skull 42, dura 44, and into the brain tissue 46. Once in the brain tissue 46, excess blood resulting from hemorrhaging may be accepted into the drainage holes 20 located on the distal region of the catheter. Due to the angle of entry into the brain, the tubular body 16 of the catheter 10 is advantageously kink resistant, in particular around a bend. Kink resistance is advantageous at the distal region 12 of the catheter 10. As the catheter 10 is withdrawn from the brain tissue 46 and begins to straighten, excess stiffness of the catheter can result in the distal tip migrating into the brain tissue 46. The presence of the drainage holes 20 contributes to the flexibility at the distal region 12 of the catheter 10.

[0094] In one embodiment, the device can be placed using a tunneling technique which involves pulling the device under the scalp away from the point of entry in the brain to reduce the probability of catheter-initiated infections. In one embodiment, the catheter is made (at least partially) of a soft and pliant silicone material (and/or similar material) which will move with the brain matter during therapy without causing injury.

[0095] Dimensions of an ultrasonic catheter may vary according to different embodiments. For example, the Wall Factor is defined as the ratio of the outer diameter of the tube to the wall thickness. The inventors have discovered that a Wall Factor of 4 is useful in preventing kinking of the catheter. In particular, a Wall Factor of 4 may prevent kinking of the catheter around a 10mm diameter bend, with the bend measured through the centerline of the catheter. The area of the tubular body 16 in which kink resistance is most advantageous is between 5 and 12 cm from the distal end of the device.

[0096] Various methods may be employed to impart kink resistance to the catheter 10. For instance, the tubular body 16 may be reinforced with coil to prevent kinking of the catheter around bends. In other embodiments, the tubular body has a wall thickness that is chosen (in light of the material) sufficient to prevent kinking as the catheter is placed through a bend.

[0097] FIGS. 4A-B illustrates one arrangement of the ultrasonic radiating elements 36. FIG. 4B is an enlarged detailed view of a cross-section along line J-J in FIG. 4A. As shown, in one arrangement, the ultrasonic radiating elements 36 can be disposed in the distal region 12 of the ultrasonic catheter 10. In other embodiments, thermocouples, pressure sensors, or other elements may also be disposed within the distal region 12. The distal region 12 may be composed of silicone or other suitable material,

designed with drainage holes 20 as discussed above. Ultrasonic radiating elements 36 may be embedded within the wall of the distal region 12, surrounded by the silicone or other material. In addition to the ultrasonic radiating elements 36, the catheter may include wiring embedded within the wall of the flexible tubular body, as discussed in more detail above with reference to FIGS. 2A-2D. The ultrasonic radiating elements 36 can include connective wiring, discussed in greater detail below. In various embodiments, there may be as few as one and as many as 10 ultrasonic radiating elements 36 can be embedded with the distal region 12 of the device. The elements 36 can be equally spaced in the treatment zone. In other embodiments, the elements 36 can be grouped such that the spacing is not uniform between them. Spacing and location of the ultrasonic radiating elements can be based on multiple factors such as, but not limited to, the desired control over flow characteristics and the number of drug delivery lumen. In an exemplary embodiment, the catheter 10 includes two ultrasonic radiating elements 36. In this two-element configuration, the elements can be spaced apart approximately 1 cm axially, and approximately 180 degrees circumferentially. In another embodiment, the catheter 10 includes three ultrasonic radiating elements 36. In this three-element configuration, the elements 36 can be spaced approximately 1 cm apart axially, and approximately 120 degrees apart circumferentially. As will be apparent to the skilled artisan, various other combinations of ultrasonic radiating elements are possible.

[0098] FIGS. 5A-B illustrates another arrangement of the distal region of an ultrasonic catheter 10. FIG. 5B is an enlarged detail view of a cross-section along line H-H in FIG. 5A. In the configuration shown, two elements are spaced approximately 180 degrees apart circumferentially, and are equidistant from the distal tip of the catheter 10. The catheter can include only two ultrasonic radiating elements 36 in the distal region 12, or alternatively it may include four, six, eight, or more, with each pair arranged in the configuration shown. In embodiments containing more than one pair, the pairs may be aligned axially. Alternatively, each pair may be rotated slightly with respect to another pair of elements. In certain embodiments, each pair of radiating elements 36 are spaced apart axially approximately 1 cm. As will be described in greater detail below, the circumferential spacing of multiple ultrasonic radiating elements can advantageously enhance the degree of control over flow patterns and the uniformity of these flow patterns.

[0099] Still referring to FIG. 5B, an epoxy housing 48 is shown, surrounded by an external layer of silicone 50. In the embodiment shown, the ultrasonic radiating elements 36 are potted in the epoxy housing 48. The epoxy may be flush with the outer diameter of silicone 50. The epoxy housing 48 may have an axial length less than the length of the distal region 12. In embodiments including multiple pairs of ultrasonic radiating elements 36, each pair of elements may be confined to a separate epoxy housing 48. In one embodiment, the epoxy housing 48 may have an axial length of between 0.75 and 0.2 inches. In other embodiments, the epoxy housing 48 may have an axial length of between 0.1 and 0.15 inches, between 0.11 and 0.12 inches, or approximately 0.115 inches.

[0100] FIGS. 6A-B show two embodiments of epoxy housings 48 in which an ultrasonic radiating element 36 may be housed. Although the housing depicted is made from epoxy, any suitable material may be used. For instance, the housing may be made from rubber, polyurethane, or any polymer of suitable flexibility and stiffness. In embodiments employing epoxy, the housing may be formed by filling a polyimide sleeve with epoxy followed by curing.

[0101] In some embodiments, epoxy housings 48 may be embedded in the silicone layer with the assistance of chemical adhesives. In other embodiments, the housings 48 may additionally contain structural designs to improve the stability of the housing within the silicone. For instance, the housing 48 shown in FIG. 6A contains a notch 52 which, when fitted with a complementary structure of a silicone layer, may improve the stability of the housing 48 within the silicone layer. Such structural designs may be used in conjunction with or independently of chemical adhesives. FIG. 6B shows another embodiment of an epoxy housing 48. In this embodiment, the raised ridge 54 is designed such that the top surface may lie flush with a silicone layer that surrounds the epoxy housing 48. The presence of ridge 54, when positioned with a complementary silicone layer structure, may help to maintain the position of the housing, and therefore of the ultrasonic radiating element, with respect to the ultrasonic catheter.

[0102] FIGS. 7A-C show an ultrasonic catheter with a modified connector 28 that can be used in combination with the arrangements and embodiments described above. The catheter 10 includes flexible tubular body. Distal to the connector 28 is the proximal port 24, which is in communication with the lumen of the tubular body 16. In the embodiment shown, the proximal port 24 is coaxial with the lumen of the tubular

body 16. In use, blood from the treatment site may enter the lumen through the drainage holes 20 located on the distal region 12 of the catheter 10. Blood may then flow through the lumen and exit through proximal port 24 into a drainage kit. In some embodiments, a negative pressure is applied to the lumen of the catheter 10 to facilitate movement of the blood or other liquids at the treatment site proximally along the lumen and out the proximal port 24. In other embodiments, no external pressure is applied, and the blood or other liquid is permitted to flow from the treatment site to the proximal port 24, unaided by external pressure. In certain types of treatment, the treatment site will possess relatively high pressure such that the natural pressure of the treatment site may cause blood or other liquids to flow from the treatment site proximally along the lumen, and out the proximal port 24.

[0103] Blood or other liquids may be drained at defined time intervals or continuously throughout the treatment. Additionally, in treatments involving intracranial hemorrhaging, by continuously draining fluid, the clot, under compression, may move towards the ultrasonic transducers for optimum ultrasound enhancement. In treatment of other diseases, continuous drainage can remove potentially toxic or other unwanted fluids from the treatment site. Additionally, such drainage can also be used to reduce pressure at the treatment site. Such reduction in pressure can be particularly important in highly sensitive areas such as the brain. Additionally, therapeutic agents may pass in the opposite direction. Such agents may enter the proximal port 24, pass distally through the lumen, and exit the catheter 10 through the drainage holes 20. In some embodiments, a positive pressure is applied to facilitate movement of the therapeutic agent or other liquid distally through the lumen and out the drainage holes 20. In other embodiments, no external pressure is applied, and the liquid is permitted to flow independently through the lumen. Therapeutic agents may be delivered in the form of a bolus within defined time intervals or continuously throughout the treatment. In order to allow for an exit path through the proximal port 24, the connector 28 is oriented at an angle with respect to the tubular body 16. In some embodiments, the connector lies at an angle between 10 and 90 degrees. In other embodiments, the connector 28 lies at an angle between 10 and 60 degrees, between 12 and 45 degrees, between 20 and 30 degrees, or approximately 22.5 degrees.

[0104] As described above with respect to other embodiments, the connector 28 may be configured to provide electrical connections to the ultrasound radiating

elements. In the embodiments shown, however, the connector 28 may lie at an angle with respect to the tubular body 16. In certain embodiments, a wire may be soldered to a contact point on the inner portion of connector 28. An electrical contact may then be exposed on the outer surface of the connector 28 to provide for an electrical connection to an individual wire. By virtue of this design, each wire, and therefore each thermocouple or element, may be addressed independently. In alternative embodiments, two or more wires may be soldered to a single contact, thereby creating a single electrical connection. In other embodiments, the wires may meet electrical contacts at other points within the catheter 10. Alternatively, the wires may pass through the wall of the tubular body 16 and connect directly to external apparatuses.

[0105] The catheter 10 may be advanced until distal region 12 reaches the desired treatment site. For instance, the catheter 10 may be advanced through the cranial cavity until it is proximate to a treatment site near the target tissue. Therapeutic agents may then be delivered to the treatment site by the path described above. For instance, thrombolytic agents may be delivered to the treatment site, in order to dissolve the blood clot. In other instances, alkylating agents, antimetabolites, and anti-tumor drugs and/or antibiotics, may be delivered to the treatment site in order to penetrate into tumors. In other instances, other types of therapeutic compounds can be used and delivered to a treatment site to treat diseased tissue at the treatment site. In certain embodiments, ultrasonic energy may then be applied to the treatment site, as discussed above. Ultrasonic energy, alone or in combination with therapeutic compounds, may advantageously expedite penetration into the target area. The ultrasonic energy may be applied continuously, periodically, sporadically, or otherwise.

[0106] A modified embodiment of an ultrasonic catheter with a proximal port is shown in FIGS. 8A-B. In the embodiment shown, the proximal port 24 is located on the flexible tubular body 16 and is in communication with the lumen of the tubular body 16. In this configuration, the proximal port 24 is perpendicular to the axis of the tubular body 16, as opposed to the configuration depicted in FIGS. 7A-C, in which the proximal port 24 is coaxial with the tubular body 16. Positioning the proximal port 24 on the wall of the tubular body 16 removes the need for the connector to lie at an angle with respect to the tubular body 16.

[0107] As discussed above, therapeutic agents may flow through proximal port 24, distally through the lumen, and may exit the catheter 10 through the drainage

holes 20 in distal region 12. Additionally, blood or other liquid may flow in the opposite direction, entering the catheter through drainage holes 20, flowing proximally through the lumen, and exiting the catheter 10 through proximal port 24 and into a drainage kit or other disposal means. Ultrasonic energy may also be applied periodically, continuously, sporadically, or otherwise throughout the process as desired. In certain embodiments, external pressure, negative or positive, may be applied in order to facilitate movement of liquids from the proximal port 24 through the lumen and out drainage holes 20, or in the opposite direction. In other embodiments, liquids are permitted to flow through the lumen, unaided by external pressure.

[0108] FIGS. 9A-F illustrate another arrangement for arranging the wires of an ultrasonic catheter. This arrangement can be used with the embodiments and arrangements described above. In this arrangement, a spiral groove extrusion 56 provides structural support to the tubular body 16. In certain embodiments, the groove extrusion 56 may be replaced by a similar structure formed by molding or any other method. The spiral groove design can provide improved kink resistance compared to a solid structure. The spiral groove extrusion 56 may be formed of a variety of different materials. For example, in one arrangement, metallic ribbons can be used because of their strength-to-weight ratios, fibrous materials (both synthetic and natural). In certain embodiments, stainless steel or tungsten alloys may be used to form the spiral groove extrusion 56. In certain embodiments, more malleable metals and alloys, e.g. gold, platinum, palladium, rhodium, etc. may be used. A platinum alloy with a small percentage of tungsten may be preferred due to its radiopacity. A sleeve 58 is arranged to slide over the spiral groove extrusion 56. The material for sleeve 58 may be formed of almost any biocompatible material, such as polyvinyl acetate or any biocompatible plastic or metal alloy. Distal extrusion 60 can house ultrasonic elements as well as drainage holes 20. The distal extrusion 60 can be formed of materials such as those described above with respect to spiral groove extrusion 56. Wires 38 are affixed to the distal extrusion 60 and connected to thermocouple or ultrasound radiating elements. A distal tip 62 is fitted to the end of distal extrusion 60.

[0109] FIG. 9C shows a cross-sectional view of the tubular body 16 taken along line N-N of FIG. 9B. Outer diameter 64 may be approximately 0.2 inches. In other embodiments, the outer diameter 64 may be approximately 0.213 inches. The inner diameter 66 may be approximately 0.1 inches. In other embodiments, the inner diameter

may be approximately 0.106 inches. As will be apparent, the dimensions of the inner and outer diameters will be selected according to the application intended based on, e.g., the diameter of the access path through the skull, the treatment site, the volume of therapeutic agent delivered, and anticipated volume of blood to be drained.

[0110] In the embodiment shown, the distal extrusion 60 may contain a window 68 in which an ultrasound radiating element may be affixed. In other embodiments, multiple ultrasonic radiating elements, each with a corresponding window 68, may be employed. As discussed above, the number, orientation, and relation of the ultrasonic radiating elements 36 may vary widely.

[0111] FIG. 9E shows a cross-sectional view of distal extrusion 60 taken along line M-M of FIG. 9D. The drainage holes 20 are, in the embodiment shown, longitudinal gaps in the external surface of the distal extrusion 60. As can be seen in FIG. 9E, the distal extrusion 60 contains four drainage holes 20, each positioned approximately 90 degrees apart circumferentially. In other embodiments, two or three longitudinal drainage holes may be employed. In exemplary embodiments, five or more longitudinal drainage holes may be used.

[0112] FIGS. 10A-D show another embodiment of an ultrasonic catheter. As with FIGS. 9A-F, a spiral groove extrusion 56 provides the structural support to the flexible tubular body 16. Sleeve 58 is dimensioned to fit over the spiral extrusion 56. In the embodiment shown, the distal extrusion 60 has been excluded. Instead, the spiral extrusion 56 includes at its distal end drainage holes 20. Additionally, sleeve 58 also contains holes 70 designed to align with the drainage holes 20 of the spiral groove extrusion 56. In some embodiments, the spiral extrusion 56 and sleeve 58 may be joined before drainage holes 20 are drilled through both layers. Wires 38 are connected to ultrasound radiating elements 36. In the embodiment shown, the ultrasound radiating elements 36 and wires 38 are arranged to lie between the spiral extrusion 56 and the sleeve 58. As discussed above, the wires may be arranged in various other configurations. In certain embodiments, the wires may be arranged to lie within the spiral groove.

[0113] FIG. 10C shows a cross-sectional view of the proximal region of the ultrasonic catheter taken along line P-P of FIG. 10B. The outer diameter 64 of the flexible tubular body 16 may be approximately 0.2 inches. In certain embodiments, the outer diameter 64 may be approximately 0.197 inches. The inner diameter 66 of the

flexible tubular body 16 may be approximately 0.01 inches. In certain embodiments, the inner diameter 66 may be approximately 0.098 inches. As described above, the dimensions of the inner and outer diameters may vary based on the intended application.

[0114] As can be seen in FIG. 10D, in certain embodiments the spiral groove may become straight at the distal region 12 of the catheter. In this arrangement, the straightened region permits drainage holes 20 to be drilled in an arrangement of rows. Additionally, ultrasonic radiating elements 36 and wires 38 may be arranged to lie within the straight portion of the groove.

[0115] FIG. 11A-I show an ultrasonic catheter assembly according to one embodiment, in which a coaxial ultrasonic core is introduced into a separate external drain.

[0116] FIGs. 11A-C illustrate one embodiment of a drain 96. The distal portion 98 of the drain 96 includes drainage holes 100. In a preferred embodiment, the drainage holes 100 may span approximately 3cm along the distal portion 98. In other embodiments, the drainage holes 100 may span shorter or longer distances, as desired. The drain 96 comprises an elongate tubular body 102, and may include distance markers 104. Distance markers 104 may be, for instance, colored stripes that surround the drain. In other embodiments, the distance markers 104 may be notches, grooves, radiopaque material, or any other material or structure that allows the regions to be visualized. The distance markers 104 may be spaced apart at regular intervals, for instance, every 2cm, 5cm, or other distance. In other embodiments they may be spaced in gradually increasing intervals, gradually decreasing intervals, irregularly, or in any other manner. In some embodiments, the distance between each marker will be written onto external surface of the drain. The presence of distance markers 104 may advantageously facilitate careful placement of the drain at a treatment site. In modified embodiments, a suture wing may be positioned at about 6 inches along the length of the catheter. Allowing a physician to visually observe the distance that the drain is advanced may improve control and placement precision.

[0117] The drain 96 includes a central lumen 106 which allows for the free flow of liquids from the drainage holes 100 towards the proximal portion 108 of the drain. As will be discussed in more detail below, in certain embodiments, any number of therapeutic compounds may be passed through the lumen 106 and out the drainage holes 100, where they then enter a treatment site. The diameter of the lumen may be

approximately 2.2mm, with an approximate outer diameter of 4.4mm. In other embodiments, these diameters may be larger or smaller, as desired. As will be apparent to one of skill in the art, the inner and outer diameters of the drain 96 will be chosen based on desired treatment site, fluid flow rate through the lumen, the material used to construct the drain, and the size of the ultrasonic core or any other element intended to pass therethrough. In one arrangement, the drain may operate at a flow rate of approximately 20 ml per hour, at a pressure of 10 mmHg.

[0118] FIGs. 11D-E show one embodiment of an ultrasonic core 110. The ultrasonic core 110 comprises an elongate shaft 112 and hub 114. Ultrasonic elements 36 are positioned coaxially with the elongate shaft 112. In certain embodiments, the ultrasonic core includes between one and four ultrasonic elements 36. In other embodiments, five or more ultrasonic elements 36 may be included. The elongate shaft 112 is dimensioned so as to be removably received within drain 96. Accordingly, in certain embodiments, the outer diameter of the elongate shaft is approximately 0.8mm, and the length of the elongate shaft is approximately 31cm.

[0119] The hub 114 is attached to elongate shaft 112 through a tapered collar 116. A proximal fluid port 118 is in fluid communication with the hub. Fluids, such as therapeutic drugs, may be injected down the core through proximal fluid port 118 towards the treatment zone. Introducing fluids in this manner may permit the use of a smaller bolus of therapeutic drug as compared to introducing fluids through the drain as discussed above. Alternatively, fluids may be injected into the lumen 106 of drain 96 through use of a Tuohy-Borst adapter attached thereto. Injecting fluids through the lumen 106 of the drain 96 may require lower injection pressure, although a larger bolus of therapeutic drug may be necessary. In either configuration, the therapeutic drug ultimately flows out of drainage holes 100 located in the distal region 98 of drain 96.

[0120] FIGs. 11F-I illustrate the catheter assembly 120 in which ultrasonic core 110 is inserted within lumen 106 of drain 96. In certain embodiments, the drain 96 may be advanced to the treatment site, followed by insertion of the ultrasonic core 110 within the drain. For instance, the drain may be tunneled under the scalp, through a bore in the skull, and into the brain. Then the ultrasonic core 110 may be inserted into the drain 96, and advanced until the elongate shaft 112 reaches the distal region 98 of drain 96.

[0121] Upon insertion, ultrasonic elements 36 may be positioned near the drainage holes 100, allowing for the application of ultrasonic energy to the treatment site. As can be seen in FIGS. 11H and 11I, the distal end of the elongate shaft 112 of ultrasonic core 110 may include one or more ultrasonic elements 36. When advanced into the distal region 98 of drain 96, the ultrasonic radiating element 36 would be located within the region containing drainage holes 100. As discussed in more detail above, application of ultrasonic energy to a treatment site may aid in dissolution of a blood clot or in penetration of therapeutic compounds to a tumor or other targeted tissue.

[0122] With reference now to Figures 12A and 12B, in alternative embodiments two separate lumens may be included, one for fluid evacuation and one for fluid delivery. In certain embodiments, continuous fluid flow may be possible. For example, application of positive pressure at the drug delivery port and simultaneous application of vacuum at the drainage port may provide for continuous removal of toxic blood components. Alternatively, influx and efflux could be accomplished separately and intermittently to allow drugs to have a working dwell time. In certain embodiments, the catheter design could spatially separate drainage holes from drug delivery holes and inlet ports, with the ultrasound transducers in between. The ultrasound radiating radially may prevent influx from going directly to efflux.

[0123] FIG. 12A-C illustrate one embodiment of an ultrasonic element and core wire. The ultrasonic core wire 114 comprises locking apertures 116 and pad 118. When integrated within a completed ultrasonic core or ultrasonic catheter, the ultrasonic core wire 114 may be embedded in silicone. The two locking apertures 116 allow for silicone to flow through the opening, thereby providing for a mechanical lock that secures the element into the silicone. The locking apertures need not be circular, but may be any shape that permits silicone to flow therethrough to create a mechanical lock. Additionally, in certain embodiments there may be one locking aperture 116. In other embodiments, there may be two, three, four, or more locking apertures 116, as desired. Ultrasonic transducers 120 are affixed to either side of pad 118. RF wires 122 are then mounted to be in communication with ultrasonic transducers 120. A polyimide shell 124 may be formed around the assembly of the pad 118, ultrasonic transducers 120, and RF wires 122, as shown in FIG. 12C. The polyimide shell may be oval-shape to aid in correct orientation of the ultrasonic element, and to minimize the use of epoxy in manufacturing.

[0124] FIG. 13 illustrates an ultrasonic element suspended in a fluid-filled chamber. The fluid-filled chamber 126 is bounded circumferentially by a polyimide shell 124, with plugs 128 defining the ends of the fluid-filled chamber. Ultrasonic core wire 114 and RF wires 122 penetrate one of the plugs 128 to enter the fluid-filled chamber 126. A fluid-tight seal is provided at the point of penetration to ensure that the chamber retains its fluid. Within the fluid-filled chamber 126 are the ultrasonic transducers 120 affixed to the ultrasonic core wire 114 and in communication with RF wires 122. This design may provide for several advantages over other configurations. For instance, potting ultrasonic elements in epoxy may lead to absorption of water by the epoxy, potentially causing delamination of an ultrasonic element from the potting material. Delamination of an element reduces the ability of the ultrasonic energy to be transferred from the ultrasonic element to the surrounding tissue. Suspending an ultrasonic element within a fluid-filled chamber may advantageously avoid this problem. The ultrasonic energy emitted by the ultrasonic elements transfers easily in fluid, and there is no risk of delamination. In addition, suspending ultrasonic elements within a fluid-filled chamber may advantageously reduce the number of components needed for an ultrasonic core, as well as potentially reducing assembly time.

[0125] FIG. 14 schematically illustrates one embodiment of a feedback control system 72 that can be used with the catheter 10. The feedback control system 72 allows the temperature at each temperature sensor 76 to be monitored and allows the output power of the energy source 78 to be adjusted accordingly. In some embodiments, each ultrasound radiating element 36 is associated with a temperature sensor 76 that monitors the temperature of the ultrasound radiating element 36 and allows the feedback control system 72 to control the power delivered to each ultrasound radiating element 36. In some embodiments, the ultrasound radiating element 36 itself is also a temperature sensor 76 and can provide temperature feedback to the feedback control system 72. In addition, the feedback control system 72 allows the pressure at each pressure sensor 80 to be monitored and allows the output power of the energy source 78 to be adjusted accordingly. A physician can, if desired, override the closed or open loop system.

[0126] In an exemplary embodiment, the feedback control system 72 includes an energy source 78, power circuits 82 and a power calculation device 84 that is coupled to the ultrasound radiating elements 36 and a pump 86. A temperature measurement device 88 is coupled to the temperature sensors 76 in the tubular body 16. A pressure

measurement device 90 is coupled to the pressure sensors 80. A processing unit 94 is coupled to the power calculation device 84, the power circuits 82 and a user interface and display 92.

[0127] In an exemplary method of operation, the temperature at each temperature sensor 76 is determined by the temperature measurement device 88. The processing unit 94 receives each determined temperature from the temperature measurement device 88. The determined temperature can then be displayed to the user at the user interface and display 92.

[0128] In an exemplary embodiment, the processing unit 94 includes logic for generating a temperature control signal. The temperature control signal is proportional to the difference between the measured temperature and a desired temperature. The desired temperature can be determined by the user (as set at the user interface and display 92) or can be preset within the processing unit 94.

[0129] In such embodiments, the temperature control signal is received by the power circuits 82. The power circuits 82 are configured to adjust the power level, voltage, phase and/or current of the electrical energy supplied to the ultrasound radiating elements 36 from the energy source 78. For example, when the temperature control signal is above a particular level, the power supplied to a particular group of ultrasound radiating elements 36 is reduced in response to that temperature control signal. Similarly, when the temperature control signal is below a particular level, the power supplied to a particular group of ultrasound radiating elements 36 is increased in response to that temperature control signal. After each power adjustment, the processing unit 94 monitors the temperature sensors 76 and produces another temperature control signal which is received by the power circuits 82.

[0130] In an exemplary method of operation, the pressure at each pressure sensor 80 is determined by the pressure measurement device 90. The processing unit 94 receives each determined pressure from the pressure measurement device 90. The determined pressure can then be displayed to the user at the user interface and display 92.

[0131] In an exemplary embodiment, the processing unit 94 includes logic for generating a pressure control signal. The pressure control signal is proportional to the difference between the measured pressure and a desired pressure. The desired pressure can be determined by the user (as set at the user interface and display 92) or can be preset within the processing unit 94.

[0132] As noted above, it is generally desirable to provide low negative pressure to the lumen in order to reduce the risk of sucking solid material, such as brain matter or other tissue surrounding the lumen, into the lumen. Furthermore, because reduction of intracranial pressure is often desirable in highly sensitive areas such as the brain, it is often desirable to deliver fluids with little pressure differential between the delivery pressure and the intracranial pressure around the catheter to prevent any injury to sensitive tissue as a result of shear and strain caused by this pressure differential. Accordingly, the processing unit 94 can be configured to monitor the pressure and modify or cease the delivery of fluid and/or increase evacuation of fluid to the treatment site if intracranial pressure increases beyond a specified limit.

[0133] In other embodiments, the pressure control signal is received by the power circuits 82. The power circuits 82 are configured to adjust the power level, voltage, phase and/or current of the electrical energy supplied to the pump 86 from the energy source 78. For example, when the pressure control signal is above a particular level, the power supplied to a particular pump 86 is reduced in response to that pressure control signal. Similarly, when the pressure control signal is below a particular level, the power supplied to a particular pump 86 is increased in response to that pressure control signal. After each power adjustment, the processing unit 94 monitors the pressure sensors 80 and produces another pressure control signal which is received by the power circuits 82.

[0134] In an exemplary embodiment, the processing unit 94 optionally includes safety control logic. The safety control logic detects when the temperature at a temperature sensor 76 and/or the pressure at a pressure sensor 80 exceeds a safety threshold. In this case, the processing unit 94 can be configured to provide a temperature control signal and/or pressure control signal which causes the power circuits 82 to stop the delivery of energy from the energy source 78 to that particular group of ultrasound radiating elements 36 and/or that particular pump 86.

[0135] Consequently, each group of ultrasound radiating elements 36 can be identically adjusted in certain embodiments. For example, in a modified embodiment, the power, voltage, phase, and/or current supplied to each group of ultrasound radiating elements 36 is adjusted in response to the temperature sensor 76 which indicates the highest temperature. Making voltage, phase and/or current adjustments in response to the temperature sensed by the temperature sensor 76 indicating the highest temperature can reduce overheating of the treatment site.

[0136] The processing unit 94 can also be configured to receive a power signal from the power calculation device 84. The power signal can be used to determine the power being received by each group of ultrasound radiating elements 36 and/or pump 86. The determined power can then be displayed to the user on the user interface and display 92.

[0137] As described above, the feedback control system 72 can be configured to maintain tissue adjacent to the energy delivery section 18 below a desired temperature. For example, in certain applications, tissue at the treatment site is to have a temperature increase of less than or equal to approximately 6 degrees C. As described above, the ultrasound radiating elements 36 can be electrically connected such that each group of ultrasound radiating elements 36 generates an independent output. In certain embodiments, the output from the power circuit maintains a selected energy for each group of ultrasound radiating elements 36 for a selected length of time.

[0138] The processing unit 94 can comprise a digital or analog controller, such as a computer with software. In embodiments wherein the processing unit 94 is a computer, the computer can include a central processing unit ("CPU") coupled through a system bus. In such embodiments, the user interface and display 92 can include a mouse, a keyboard, a disk drive, a display monitor, a nonvolatile memory system, and/or other computer components. In an exemplary embodiment, program memory and/or data memory is also coupled to the bus.

[0139] In another embodiment, in lieu of the series of power adjustments described above, a profile of the power to be delivered to each group of ultrasound radiating elements 36 can be incorporated into the processing unit 94, such that a preset amount of ultrasonic energy to be delivered is pre-profiled. In such embodiments, the power delivered to each group of ultrasound radiating elements 36 is provided according to the preset profiles.

[0140] In an exemplary embodiment, the ultrasound radiating elements are operated in a pulsed mode. For example, in one embodiment, the time average power supplied to the ultrasound radiating elements is between about 0.1 watts and about 2 watts. In another embodiment, the time average power supplied to the ultrasound radiating elements is between about 0.5 watts and about 1.5 watts. In yet another embodiment, the time average power supplied to the ultrasound radiating elements is approximately 0.6 watts or approximately 1.2 watts. In an exemplary embodiment, the

duty cycle is between about 1% and about 50%. In another embodiment, the duty cycle is between about 5% and about 25%. In yet another embodiment, the duty cycle is approximately 7.5% or approximately 15%. In an exemplary embodiment, the pulse averaged power is between about 0.1 watts and about 20 watts. In another embodiment, the pulse averaged power is between approximately 5 watts and approximately 20 watts. In yet another embodiment, the pulse averaged power is approximately 8 watts or approximately 16 watts. The amplitude during each pulse can be constant or varied.

[0141] In an exemplary embodiment, the pulse repetition rate is between about 5 Hz and about 150 Hz. In another embodiment, the pulse repetition rate is between about 10 Hz and about 50 Hz. In yet another embodiment, the pulse repetition rate is approximately 30 Hz. In an exemplary embodiment, the pulse duration is between about 1 millisecond and about 50 milliseconds. In another embodiment, the pulse duration is between about 1 millisecond and about 25 milliseconds. In yet another embodiment, the pulse duration is approximately 2.5 milliseconds or approximately 5 milliseconds.

[0142] For example, in one particular embodiment, the ultrasound radiating elements are operated at an average power of approximately 0.6 watts, a duty cycle of approximately 7.5%, a pulse repetition rate of approximately 30 Hz, a pulse average electrical power of approximately 8 watts and a pulse duration of approximately 2.5 milliseconds.

[0143] In an exemplary embodiment, the ultrasound radiating element used with the electrical parameters described herein has an acoustic efficiency greater than approximately 50%. In another embodiment, the ultrasound radiating element used with the electrical parameters described herein has an acoustic efficiency greater than approximately 75%. As described herein, the ultrasound radiating elements can be formed in a variety of shapes, such as, cylindrical (solid or hollow), flat, bar, triangular, and the like. In an exemplary embodiment, the length of the ultrasound radiating element is between about 0.1 cm and about 0.5 cm, and the thickness or diameter of the ultrasound radiating element is between about 0.02 cm and about 0.2 cm.

[0144] With reference now to FIG. 15, in one embodiment of a treatment protocol, patients can be taken to an operating room and placed under general anesthesia for ultrasound and drainage catheter insertion. Patients can be registered using electromagnetic (EM) stealth, based on CT parameters for stereotactic placement of catheters using the Medtronic EM Stealth navigation system. However, as described

above, in modified embodiments, other navigation techniques and tools could be used. Using such navigation systems, an entry point for the burr hole and hemorrhage target location for the catheter tips can be chosen. It should be appreciated that the location of the burr-hole or drill hole can be selected to reduce the path length between the target tissue and the hole in the patient's skull. In addition, it may be desirable in some cases to approach the targeted tissue from an angle that avoids certain portions of the brain.

[0145] In the illustrated embodiment, a Stealth guidance system (or other guidance system or technique) can be used to place a 12 French peel-away introducer through the burr hole into the desired location in the hemorrhage, to accommodate placement of the ultrasonic catheter 10. In modified arrangements, a different size and/or type of introducer could be used and/or the ultrasonic catheter can be inserted without an introducer.

[0146] As shown in FIG. 15, the catheter 10 can be with the peel away introducer and the position confirmed by neuro-navigation or other navigation technique. In one embodiment, the two catheters can then be tunneled out through a separate stab wound in the skin and secured to the patient. A portable CT scan can be done at the completion of the procedure to confirm acceptable catheter placement. In one embodiment, the distal tip of the ultrasonic catheter 10 is generally positioned along the longitudinal center (measured along the axis of the catheter) of the hemorrhage. As described above, in other embodiments, an ultrasonic core can be placed through a lumen in the catheter (see e.g., FIGS 1A-F). In other embodiments, the ultrasonic catheter can be placed along side the catheter.

[0147] Ultrasound energy can be delivered for a duration sufficient to enable adequate drug distribution in and/or around the target tissue. This can be accomplished by either intermittent or continuous delivery of ultrasound energy. For example, ultrasound energy can be delivered for a set time period to adequately distribute the drug to the target tissue, and then turned off to allow the drug to act on the target tissue. Alternatively, ultrasound energy can be delivered substantially continuously after the drug has been delivered to the target tissue to continuously redistribute the drug into the target tissue and continuously enhance the drug penetration into such tissue. In addition, ultrasound energy can be delivered intermittently to reduce heating. Also, as described in U.S. Application 11/971,172, filed January 8, 2008, which is hereby incorporated by reference herein in its entirety, the power parameters controlling the delivery of

ultrasound energy can be randomized or varied according to complex non-linear algorithms in order to enhance the efficacy of the ultrasound treatment.

[0148] Drug delivery can be controlled by monitoring, for example, byproducts of the metabolized drug. For example, in the treatment of blood clots with lytic compounds, lysis byproducts such as D-dimer in the effluent evacuated from the blood clot can be monitored. A high and/or increasing concentration of D-dimer in the effluent can indicate that lysis of the blood clot is proceeding adequately, and therefore drug delivery can be maintained, reduced or stopped. A low or decreasing concentration of D-dimer in the effluent can indicate that lysis of the blood clot is inadequate or slowing or that the clot is nearly dissolved, and therefore drug delivery can be increased if the clot is not nearly dissolved, and reduced or stopped if lysis is almost complete. Alternatively, the concentration of the drug can be monitored to determine whether more drug should be delivered and whether treatment is complete. In some embodiments involving treatment of blood clots, as lysis of the blood clot proceeds, lytic is freed from the lysed clot, thereby increasing the concentration of lytic in the effluent. Therefore, increased lytic concentration can correlate to lysis completion. One way of determining the concentration of lytic and/or D-dimer in the effluent is to measure the color of the effluent that is evacuated from the blood clot. The redder the effluent, the greater the concentration of lytic and/or D-dimer in the effluent.

[0149] In some embodiments, neuroprotective drugs or agents that assist in the functional recovery and/or the reduction of cell and tissue damage in the brain can also be delivered to the brain and blood clot with the methods and apparatus described above. These neuroprotective drugs or agents can be delivered before, with, or after the delivery of the thrombolytic drugs. Delivery of these drugs using the methods and apparatus described above is particularly useful where the drug delivery through the blood brain barrier is enhanced with ultrasound treatment, or where ultrasound enhances cell penetration by the drug, or where the drug is sonodynamic.

[0150] Another embodiment of an ultrasonic catheter is shown in FIGS. 16A-E. Similar to the embodiments described above with respect to FIGS. 2A-D, the catheter includes wires 38 embedded within the wall of the tubular body 16. The wires 38 are connected to and may control ultrasonic radiating elements 36 located within the distal region 12 of the catheter 10. The wires extend from the proximal end of the tubular body 16. In certain embodiments, the wires extend more than six inches from the proximal

end, so as to facilitate electrical connection with external devices. Drainage holes 20 are positioned in the distal region 12 of the catheter 10, near the ultrasonic radiating elements 36. In other embodiments, thermocouples, pressure sensors, or other elements may also be disposed within the distal region 12. The distal region 12 may be composed of silicone or other suitable material, designed with drainage holes 20 as discussed above. Ultrasonic radiating elements 36 may be embedded within the wall of the distal region 12, surrounded by the silicone or other material. In various embodiments, there may be as few as one and as many as 10 ultrasonic radiating elements 36 can be embedded with the distal region 12 of the device. The elements 36 can be equally spaced in the treatment zone. In other embodiments, the elements 36 can be grouped such that the spacing is not uniform between them. In an exemplary embodiment illustrated in FIGS. 16B-D, the catheter 10 includes four ultrasonic radiating elements 36. In this four-element configuration, the elements can be spaced apart as pairs, with each pair located at a similar longitudinal position, but separated by 180 degrees circumferentially. The pairs of offset from one another both by 90 degrees circumferentially and by a longitudinal distance along the length of the catheter 10. As will be apparent to the skilled artisan, various other combinations of ultrasonic radiating elements are possible.

[0151] In some embodiments, the ultrasound radiating elements can be used to generate a steady current in a fluid around the ultrasound radiating elements. In embodiments where the ultrasound radiating elements are placed on or in a catheter, this can allow the generation of a current through fluid surrounding the catheter. By generating a current through fluid surrounding the catheter, it is possible to advantageously direct the flow of a therapeutic compound introduced into the fluid towards a target area, such as diseased tissue. This can advantageously enhance the effect of the therapeutic compound by more directly targeting only those areas on which the therapeutic compound should act. Accordingly, this can reduce the dosage of therapeutic compound thereby reducing side-effects.

[0152] Without limiting the scope of this disclosure to a particular theory of operation, this steady current in the fluid, known as “acoustic streaming,” can be driven by absorption of acoustic oscillations created by the acoustic waves emitted by the ultrasound radiating elements. Based on the sequence of activation, it is possible to create fluid flow in desired directions around the catheter.

[0153] FIGS. 17A–D illustrates potential sequencing and synchronization of activation of ultrasonic radiating elements within an ultrasound catheter 1700 placed within a target site 1701 of the body including, but not limited to, a cavity (e.g., the cranial cavity, a blood vessel, or a self-created cavity e.g., a surgical incision) or in other a tissue (e.g., a tumor, brain tissue etc.). The methods and apparatuses described below can be used in combination with the embodiments described above with reference to FIGS. 1A-16E. In particular, the sequencing and synchronization of the ultrasonic radiating elements can be used in the embodiments described above to direct flow of a therapeutic compound. In an exemplary embodiment, the sequencing and synchronization can be performed by the processing unit 94 (as shown in FIG. 14) which may additionally include logic configured to allow the processing unit 94 to selectively activate ultrasonic radiating elements in an embodiment of the ultrasound catheter (e.g., the embodiments described above). In the illustrated embodiment, the ultrasound catheter 1700 includes ultrasound radiating elements 1702, 1704, 1706, 1708, 1710, and 1712 and passages 1714, 1718, 1722, and 1726. Passages 1714, 1718, 1722, and 1726 are in fluid communication with lumen 1716, 1720, 1724, and 1728 respectively with each lumen being in fluid communication with a separate port at a proximal end of the catheter. Ultrasound radiating elements 1702, 1704, 1706, 1708, 1710 and 1712 can be separate ultrasound radiating units or separate portions of a single ultrasound radiating unit. Some or all of the passages 1714, 1718, 1722, and 1726 can be configured to allow therapeutic compounds, input into ports at the proximal end of the device, to pass through and out of these holes. Such therapeutic compounds can be used to treat diseases or ailments in any part of the body such as vascular occlusions, blood clots, cancer, and any other type of disease or ailment. Alternatively, some or all of the passages 1714, 1718, 1722, and 1726 can be configured to remove fluid from the implantation location, through the corresponding lumen, and out of the ports at a proximal end of the catheter. As such, some passages 1714, 1718, 1722, and 1726 can be used to deliver therapeutic compounds to the target location while others can be used to remove fluids from the target location. In other embodiments, fewer or greater numbers of radiating elements and/or drainage holes can be used (see e.g., the embodiments described above with respect to FIGS. 1A-16E). Furthermore, in other embodiments, the radiating elements 1702, 1704, 1706, 1708, 1710, and 1712 may be placed closer to or at the center of the ultrasound catheter 1700. In some embodiments, the passages can be coupled to a common or single lumen.

[0154] In one embodiment, the ultrasound radiating elements 1702, 1704, 1706, 1708, 1710, and 1712 are activated in sequence such that the pattern of pressure waves created by activation of individual elements creates a flow throughout the target area. For example, in one embodiment as shown in FIG. 17B, a first pair of ultrasound radiating elements 1702 and 1704 are activated for a first interval at a first point in time which create a first pressure wave 1730b. This pressure wave causes fluid to flow in the directions shown by arrows 1732b and 1734b. Fluid to the left of element 1702 and 1704 moves in the direction of arrow 1732b while fluid to the right of element 1702 and 1704 moves in the direction of arrow 1734b. Subsequently, as shown in FIG. 17C, a second pair of ultrasound radiating elements 1706 and 1708 are activated for a second interval at a second point in time creating a second pressure wave 1730c. This causes fluid to flow in the direction of arrows 1732c and 1734c. Finally, as shown in FIG. 17D, a third pair of ultrasound radiating elements 1710 and 1712 are activated for a third interval at a third point in time creating third pressure wave 1730d. This causes fluid to flow in the direction of arrows 1732d and 1734d. So long as the elements are activated for a sufficient interval, fluid containing the therapeutic compounds can flow distal the subsequent pair of elements. Therefore, activation of a subsequent pair of elements causes the fluid containing the therapeutic compounds to flow even further distal the second pair of elements.

[0155] It should be apparent to one of skill in the art that the length of the intervals and the delay between the points in time can be configured based on the desired flow rate and the characteristics of the fluid. Therefore, in some embodiments, the intervals are such that there is no overlap in activation between subsequent pairs of ultrasound radiating elements. In other embodiments, the intervals are such that there is some overlap in activation between subsequent pairs of ultrasound radiating elements such that, at least during one point in time, two pairs are simultaneously activated. By activating the ultrasound radiating elements in this sequence, pressure waves can cause fluid to flow from the location of the first pair of ultrasound radiating elements 1702 and 1704 to a distal end of the ultrasound catheter 1700. This flow path can potentially reduce the likelihood of fluid containing the therapeutic compounds to travel against the desired flow path (i.e., backflow) thereby delivering a more substantial amount of the therapeutic compounds to the target area and reducing the amount of therapeutic compounds entering areas not targeted for treatment. It should be appreciated by one of

skill in the art that increasing the number of ultrasound radiating elements around the circumference of the ultrasound catheter 1700 can likely provide a more advantageous safeguard against backflow.

[0156] In another embodiment, the activation of ultrasound radiating elements 1702, 1704, 1706, 1708, 1710, and 1712 may be differed to change flow patterns around the ultrasound catheter. For example, the ultrasound radiating elements may be activated in sequence in the following order – 1702, 1706, 1710, 1712, 1708, and 1704 – to create a flow path in which fluid along the top of the ultrasound catheter 1700 flows in a direction from the proximal end to the distal end whereas fluid along the bottom of the ultrasound catheter 1700 flows in a direction from the distal end to the proximal end. Such a flow pattern can be advantageous, for example, when the top passages 1714 and 1722 are configured to deliver therapeutic compounds to the target area and bottom passages 1718 and 1726 are configured to remove fluid, such as toxic product, from the target area. Fluid flow across the top passages 1714 and 1722 can cause therapeutic compounds to pass through and out of the top passages 1714 and 1722. Other activation sequences are contemplated which can alter the flow characteristics around the ultrasound catheter 1700. As such, the amount of positive pressure used at the top passages 1714 and 1722 can be advantageously reduced while still being delivered fully to the target area and the amount of negative pressure used at the bottom passages 1718 and 1726 can also be advantageously reduced while still removing the same amount of fluid. This can reduce the likelihood of injuries being sustained by tissue proximate the ultrasound catheter 1700 caused either by positive pressure or by negative pressure.

[0157] In yet another embodiment, the activation of ultrasound radiating elements 1702, 1704, 1706, 1708, 1710, and 1712 can be synchronized with delivery of therapeutic compounds through passages 1714, 1718, 1722, and 1726. In one embodiment, no pumps are attached to the separate lumen 1716, 1720, 1724, and 1728. Rather, activation of the ultrasound radiating elements can be used to generate a flow pattern which could subsequently cause therapeutic compounds to pass through the lumen and out of the corresponding passages. In another embodiment, pumps are attached to the separate lumen and are used to eject therapeutic compounds out of the passages. Activation of ultrasound radiating elements can be synchronized with the activation of pumps such that therapeutic compounds delivered through different passages can be delivered to different target locations. In one non-limiting embodiment, a pump can

cause a first therapeutic compound to pass out of passags 1714. Subsequent to this, ultrasound radiating element 1702 can then be activated. In sequence, element 1706 can then be activated followed by element 1710 such that the first therapeutic compound is delivered to a location that is distal of element 1710. In this embodiment, a pump can also cause a second therapeutic compounds to pass out of passage 1722. In this embodiment, only element 1706 is activated such that the second therapeutic compound is delivered to a location proximal the delivery location of the first therapeutic compound. As should be apparent to one of skill in the art, a greater number of radiating elements along the length of the ultrasound catheter can be used to provide greater control over the final location of the therapeutic compounds.

[0158] Devices and techniques can be used with the ultrasound radiating elements as herein described to control the transmission of ultrasound energy. Such devices and techniques can be used, for example, to reduce the efficiency of ultrasound energy in certain directions. Moreover, such devices and techniques can be used to focus the output of ultrasound in a desired direction.

[0159] FIGS. 18A-18C illustrate an embodiment of an ultrasound assembly 1810 having a cavity 1830 which when used with the embodiments described above can reduce the portion of ultrasound energy transmitted in a direction towards the cavity 1830 while increasing the portion of ultrasound energy transmitted in a direction away from the cavity 1830. This can increase the efficiency in delivering ultrasound energy produced from these sections in desired areas. Moreover, this can reduce the flow effects of the ultrasound energy on fluid contained within the catheter such as fluid flow through lumens of the catheter. It should be understood that the cavity 1830 as herein described can be used for any of the ultrasound catheters and assemblies as herein described.

[0160] The ultrasound assembly 1810 can include an elongated body 1812 having a lumen 1813 and external surface 1814. A plurality of spacers 1816 can be positioned over the external surface 1814 of an elongated body 1812 and a member 1818 can be positioned over at least a portion of the spacers 1816. The ultrasound assembly 1810 can also include an ultrasound transducer 1820 with an external side 1822 and an internal side 1824 between a first end 1826 and a second end 1828. In some embodiments, the ultrasound transducer 1820 can be positioned over the member 1818 and can surround the member 1818. In some embodiments, the ultrasound transducer 1820 can also only partially surround the member 1818. Suitable materials for the

member 1818 include, but are not limited to, polyimide, polyester and nylon. A suitable ultrasound transducer 1820 includes, but is not limited to, PZT-4D, PZT-4, PZT-8 and various piezoceramics.

[0161] The internal side 1824 of the ultrasound transducer 1820, the spacers 1816 and the member 1818 each define a portion of a chamber 1830 between the internal side 1824 of the ultrasound transducer 1820 and the external surface 1814 of the elongated body 1812. The chamber 1830 can preferably have a height between about 0.25 μm to about 10 μm , more preferably between about 0.50 μm to about 5 μm , and most preferably between about 1 μm to about 1.5 μm . The chamber 1830 can preferably have a width between about 12 μm to about 2500 μm , more preferably between about 25 μm to about 250 μm , and most preferably between about 25 μm to about 125 μm . Of course, other heights and widths for chamber 1830 can also be used. The member 1818 can extend beyond the first end 1826 and/or the second end 1828 of the ultrasound transducer 1820. Additionally, the spacers 1816 can be positioned beyond the ends of the ultrasound transducer 1820. As a result, the chamber 1830 can extend along the longitudinal length of the ultrasound transducer 1820 to increase the portion of the ultrasound transducer 1820 which is adjacent to the chamber 1830.

[0162] The chamber 1830 can contain a low acoustic impedance medium. The low acoustic impedance material within the chamber can reduce the portion of ultrasound energy which is transmitted through the chamber 1830. Suitable low acoustic impedance media include, but are not limited to, fluids such as helium, argon, air and nitrogen and/or solids such as silicone and rubber. The chamber 1830 can also be evacuated. Suitable pressures for an evacuated chamber 1830 include, but are not limited to, negative pressures to -760 mm Hg. Generally, a low acoustic impedance medium has an acoustic impedance less than about 1.7 Megarayls, preferably between about 0 Megarayls to about 0.7 Megarayls, and more preferably between about 0 Megarayls to about 0.4 Megarayls. Of course, acoustic impedance mediums having acoustic impedances outside of these ranges can also be used. It should be understood that other methods of creating a chamber 1830 are contemplated including manufacturing a monolithic catheter having a chamber 1830 formed therein. Additional embodiments of such cavities as well as catheters and ultrasound assemblies can be found in U.S. Patent No. 6,676,626, issued January 13, 2004, which is hereby expressly incorporated by reference.

[0163] While the chamber 1830 which can be filled with a low acoustic impedance medium to reduce transmission of ultrasound energy through the chamber 1830, it should be understood that chamber 1830 need not be filled with a specific material. Moreover, while the chamber 1830 has been described as having spacers 1816 at each end of the chamber 1830, spacers 1816 need not be attached at each end. For example, the chamber 1830 can be formed between the elongated body 1812 and the member 1818 with the member 1818 directly attached to the elongate body 1812.

[0164] Transmission of ultrasound energy can be affected introducing other types of gaps, including microscopic gaps, between separate components of the ultrasound catheter. For example, in some embodiments, one or more gaps can be created by delaminating one or more material layers of a component of the ultrasound catheter. In some embodiments, the gap is not filled with any material after delamination of these layers. In other embodiments, the gaps can be filled with an additional material after delamination. Such delamination can result in one or more gaps having heights lesser than those described above with respect to the chamber 1830.

[0165] The gap can function similar to chamber 1830 and cause inefficient transmission of ultrasound through the portions of the ultrasound catheter having such gaps. In some embodiments, the gap can be formed on portions of the ultrasound catheter between the ultrasound radiating element and the central portion of the ultrasound catheter. Accordingly, the amount of ultrasound energy transmitted towards the interior of the ultrasound catheter can be reduced and the amount of ultrasound energy transmitted away from the interior of the ultrasound catheter can be enhanced. Of course, other configurations of one or more gaps can also be chosen to alter the characteristics of ultrasound energy and enhance the directionality of this energy. This can be particularly beneficial to create an ultrasound catheter having more precise targeting and/or a more efficient device.

[0166] While the foregoing detailed description has set forth several exemplary embodiments of the apparatus and methods of the present invention, it should be understood that the above description is illustrative only and is not limiting of the disclosed invention. It will be appreciated that the specific dimensions and configurations disclosed can differ from those described above, and that the methods described can be used within any biological conduit within the body.

LISTING OF EMBODIMENTS:

1. A method of increasing the efficacy of drugs delivered to a target location, comprising the steps of:

providing an ultrasound catheter having one or more ultrasound radiating elements and one or more drainage holes configured to allow one or more therapeutic compounds to pass through and out of the one or more drainage holes;

passing a therapeutic compound out of the drainage hole at the target location; and
activating the one or more ultrasound radiating elements;

wherein activating the one or more ultrasound radiating elements is configured to increase the efficacy of the therapeutic compound.

2. The method of Embodiment 1, wherein the ultrasound radiating element is configured to increase the permeability of the targeted area.

3. The method of Embodiment 1, wherein the step of activating the one or more ultrasound radiating elements additionally comprises activating the one or more ultrasound radiating elements in a sequence configured to cause fluid to flow in a desired direction.

4. The method of Embodiment 3, wherein the fluid flows towards the target area.

5. The method of Embodiment 3, wherein the fluid flows away from the target area.

6. The method of Embodiment 4, wherein the ultrasound catheter further comprises one or more pumps in fluid communication with the one or more drainage holes and wherein the step of activating the one or more ultrasound radiating elements additionally comprises synchronizing the activation of the one or more ultrasound radiating elements with the one or more pumps.

7. The method of Embodiment 6, wherein synchronization of the activation of the one or more ultrasound radiating elements is configured to transport drugs to different target areas.

8. The method of Embodiment 6, wherein synchronization of the activation of the one or more ultrasound radiating elements is configured to at least partially causing the one or more therapeutic compounds to pass through and out of the one or more drainage holes.

9. The method of Embodiment 3, wherein synchronization of the activation of the one or more ultrasound radiating elements is configured to at least partially causing the one or more therapeutic compounds to pass through and out of the one or more drainage holes.

WHAT IS CLAIMED IS:

1. A method of delivering compounds to a target region, comprising the steps of:

advancing an ultrasound catheter to the target region, the ultrasound catheter comprising two or more ultrasound radiating elements and a first passage, wherein the two or more ultrasound radiating elements are spaced apart longitudinally along the ultrasound catheter;

introducing a first therapeutic compound to the target location via the first passage; and

sequentially activating the two or more ultrasound radiating elements such that the first therapeutic compound is directed to a first target area.

2. The method of Claim 1, wherein the step of sequentially activating the two or more ultrasound radiating elements comprises alternately activating adjacent ultrasound radiating elements such that at least a portion of the fluid proximate a proximal-most ultrasound radiating element flows distal the activated ultrasound radiating elements.

3. The method of Claims 1 or 2, wherein the step of sequentially activating the two or more ultrasound radiating elements comprises alternately activating adjacent ultrasound radiating elements such that at least a portion of the fluid proximate a distal-most radiating element flows proximal the activated ultrasound radiating elements.

4. The method according to any of Claims 1 to 3, wherein the step of sequentially activating the two or more ultrasound radiating elements comprises simultaneously activating two or more ultrasound radiating elements such that at least a portion of the fluid remains between the activated ultrasound radiating elements.

5. The method according to any of Claims 1 to 4, wherein step of introducing a first therapeutic compound into the target region comprises activating a first pump in fluid communication with the first passage.

6. The method according to any of Claims 1 to 5, further comprising synchronizing the activation of the two or more ultrasound radiating elements with the activation of the first pump such that the first therapeutic compound is directed to the first target area

7. The method according to any of Claims 1 to 6, wherein the ultrasound catheter further comprises a second passage.

8. The method of Claim 7, further comprising draining fluid from the cavity through the second passage.

9. The method according to Claim 7, further comprising introducing a second therapeutic compound into the cavity via the second passage and sequentially activating the two or more ultrasound radiating elements such that the second therapeutic compound is directed to a second target area.

10. The method according to any of Claims 1 to 9, further comprising increasing the permeability of the target region using at least one of the first and second ultrasound radiating elements.

11. An apparatus for delivering drugs to a target region, the apparatus comprising:

an ultrasound catheter comprising:

a tubular body comprising a first lumen;

two or more ultrasound radiating elements spaced apart longitudinally along the tubular body; and

a first passage in fluid communication with the lumen; and

a processing unit, the processing unit configured to selectively activate ultrasound radiating elements to control the flow of a fluid surrounding the ultrasound catheter.

12. The apparatus of Claim 11, further comprising a pump in fluid communication with the lumen, the pump configured to pump a first therapeutic compound through the lumen and out of the first passage.

13. The apparatus of Claim 11 or 12, further comprising a second passage in fluid communication with a second lumen.

14. The apparatus of Claim 13, further comprising a second pump in fluid communication with the second lumen.

15. The apparatus of Claim 11, wherein the processing unit is configured to alternately activate adjacent ultrasound radiating elements such that at least a portion of the fluid proximate a proximal-most ultrasound radiating element flows distal the activated ultrasound radiating elements.

16. The apparatus of Claim 11, wherein the processing unit is configured to alternately activate adjacent ultrasound radiating elements such that at least a portion of

the fluid proximate a distal-most radiating element flows proximal the activated ultrasound radiating elements.

17. The apparatus of Claim 11, wherein the processing unit is configured to simultaneously activate two or more ultrasound radiating elements such that at least a portion of the fluid remains between the activated ultrasound radiating elements.

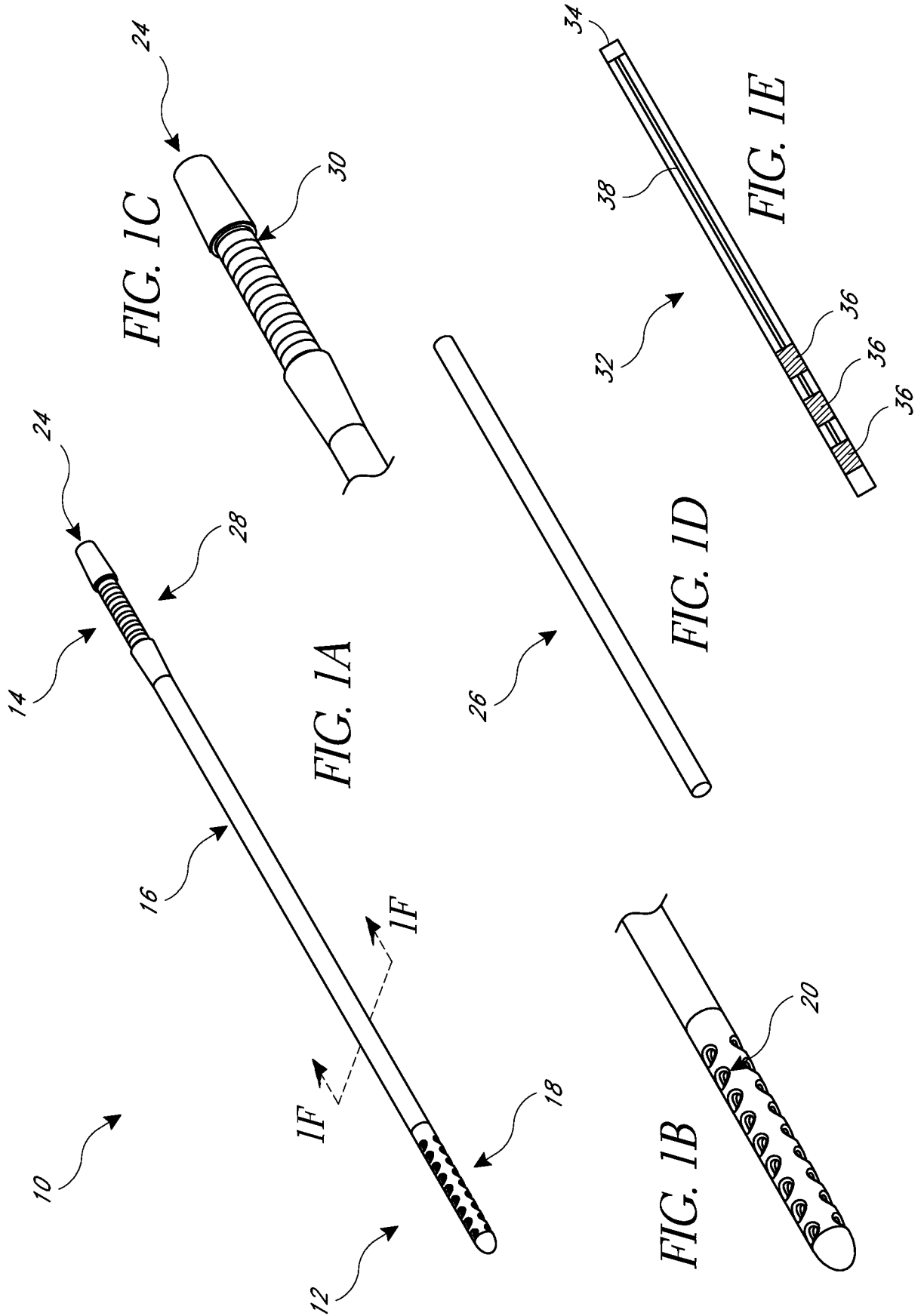

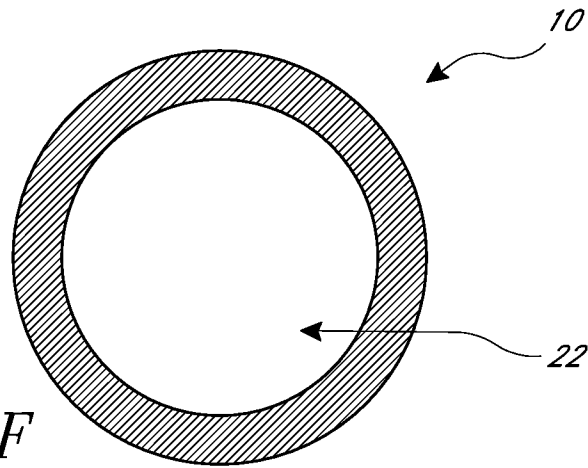

FIG. 1F

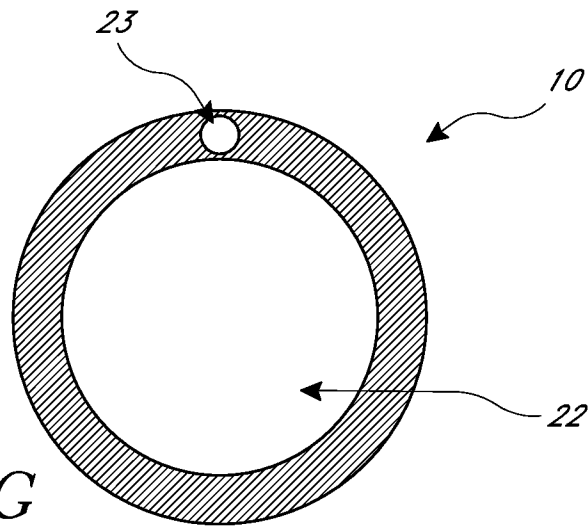

FIG. 1G

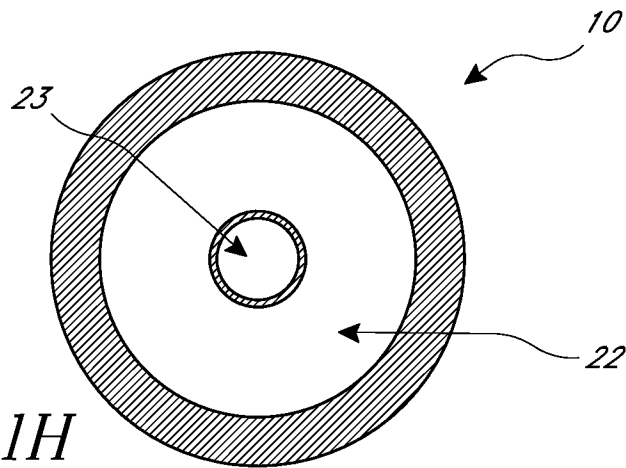

FIG. 1H

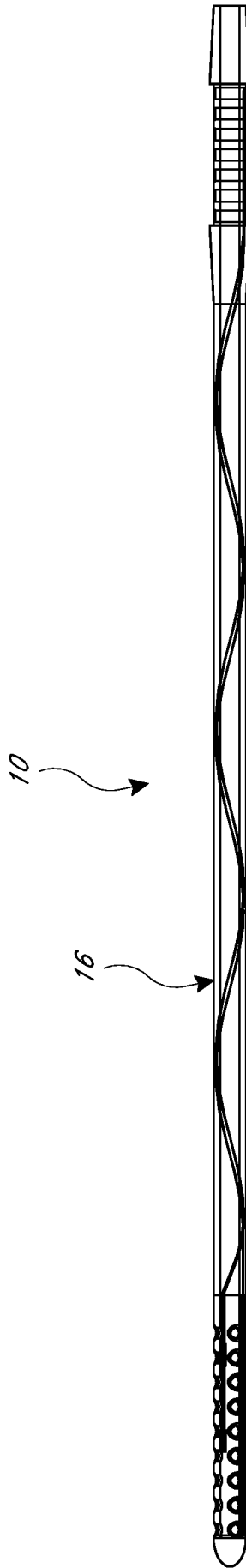

FIG. 2A

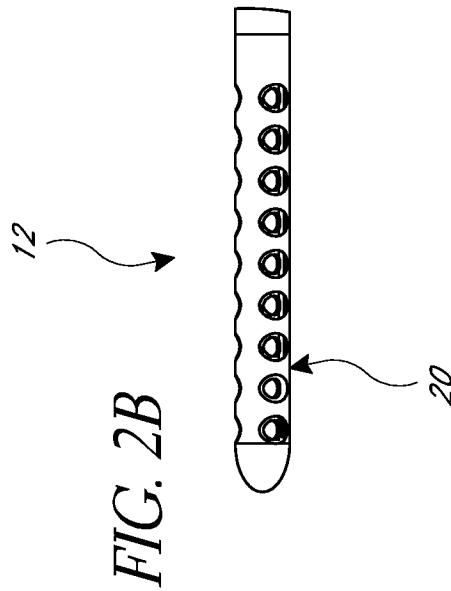

FIG. 2B

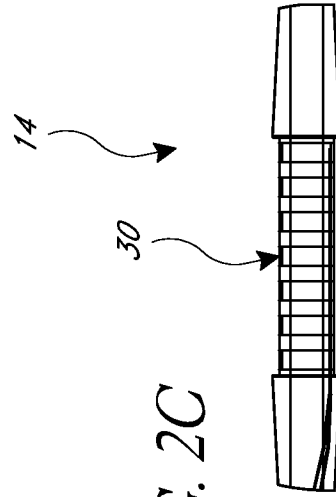

FIG. 2C

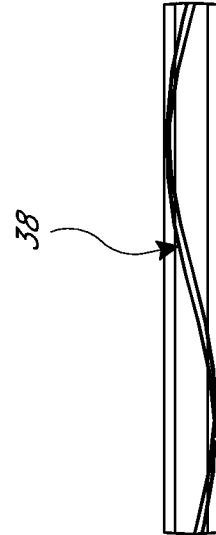

FIG. 2D

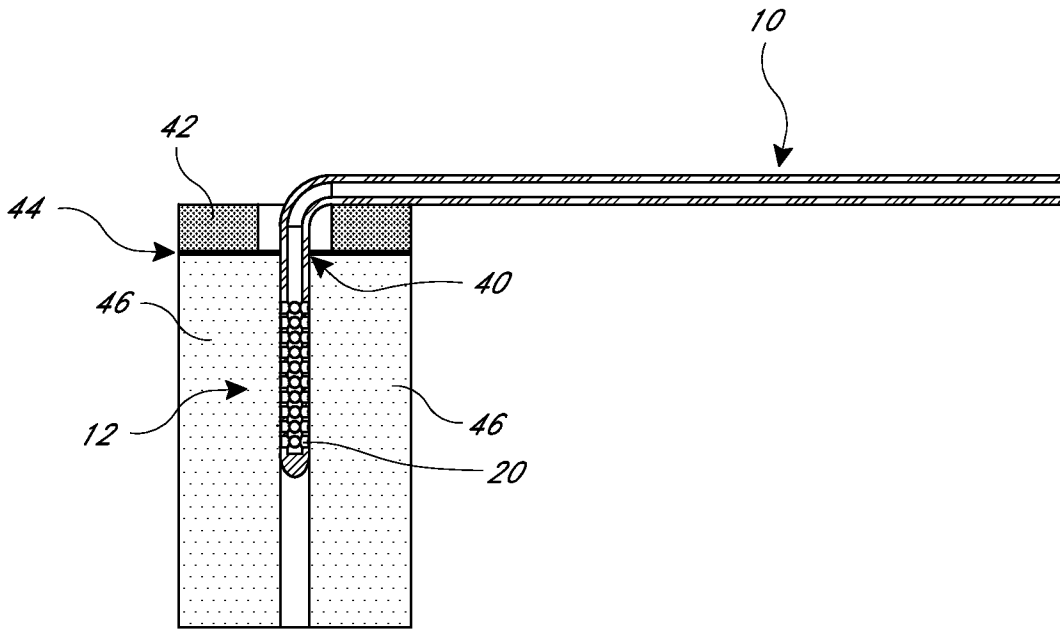
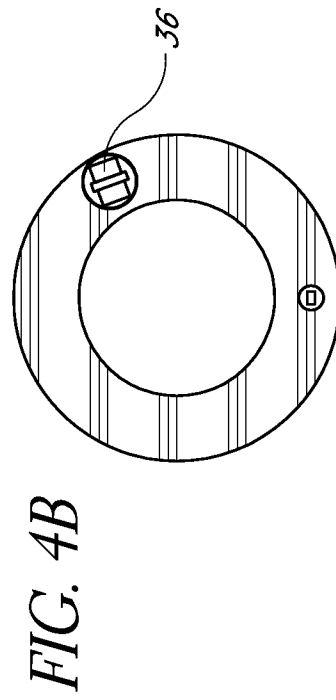
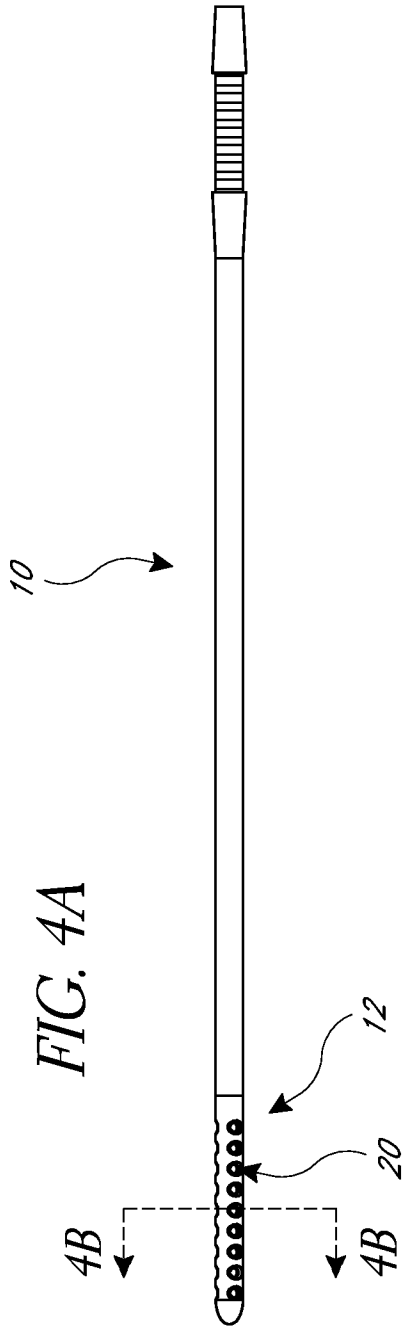

FIG. 3



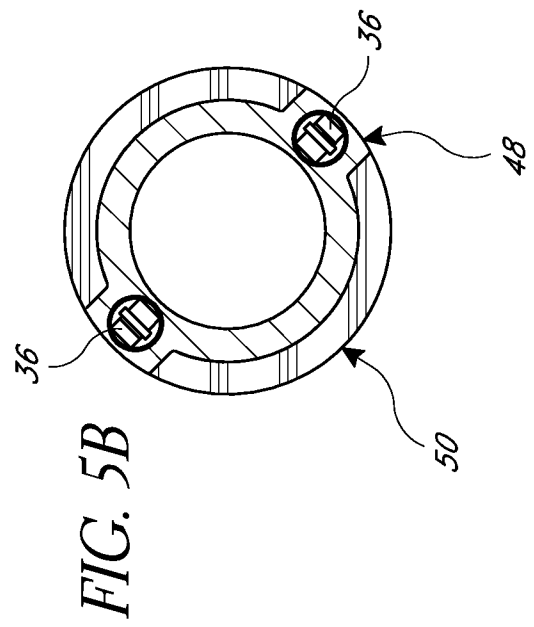
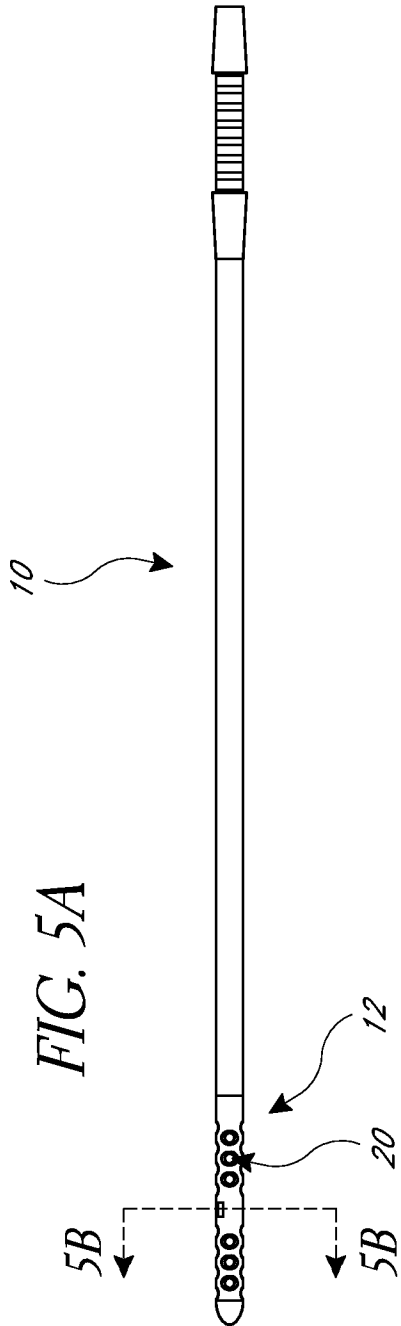

FIG. 6A

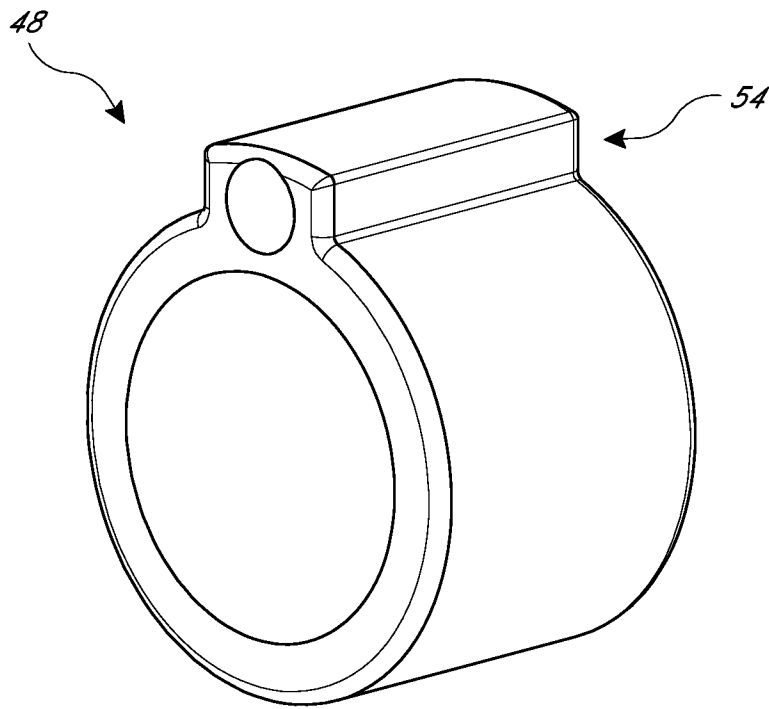
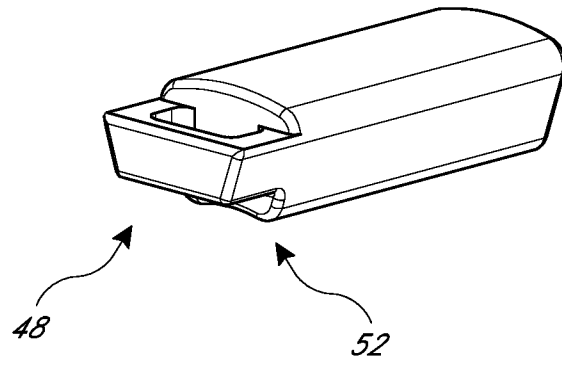

FIG. 6B

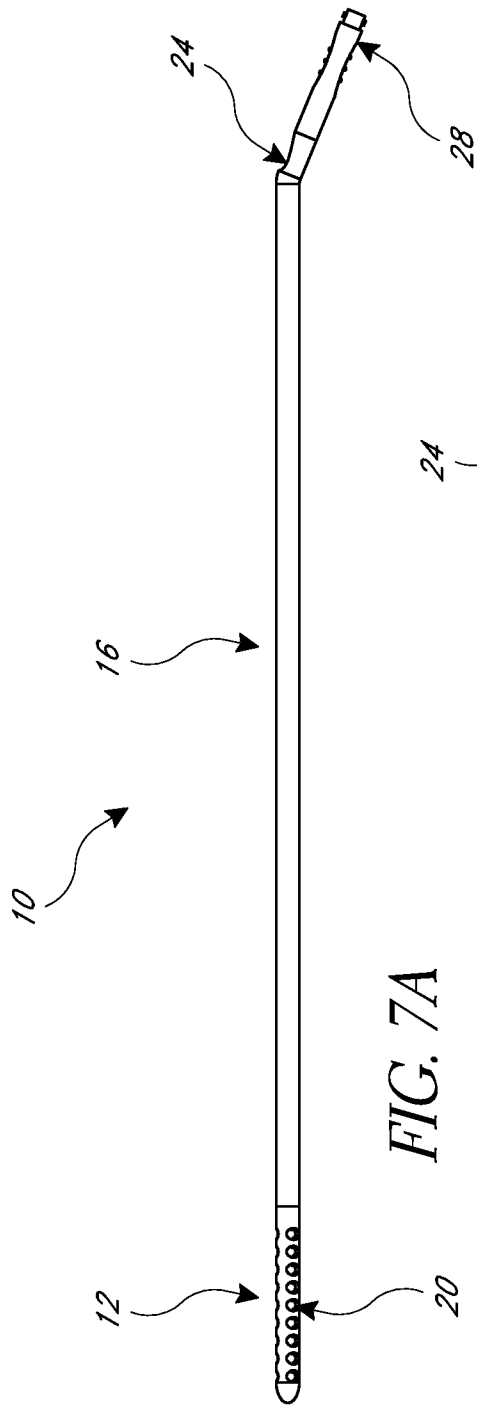
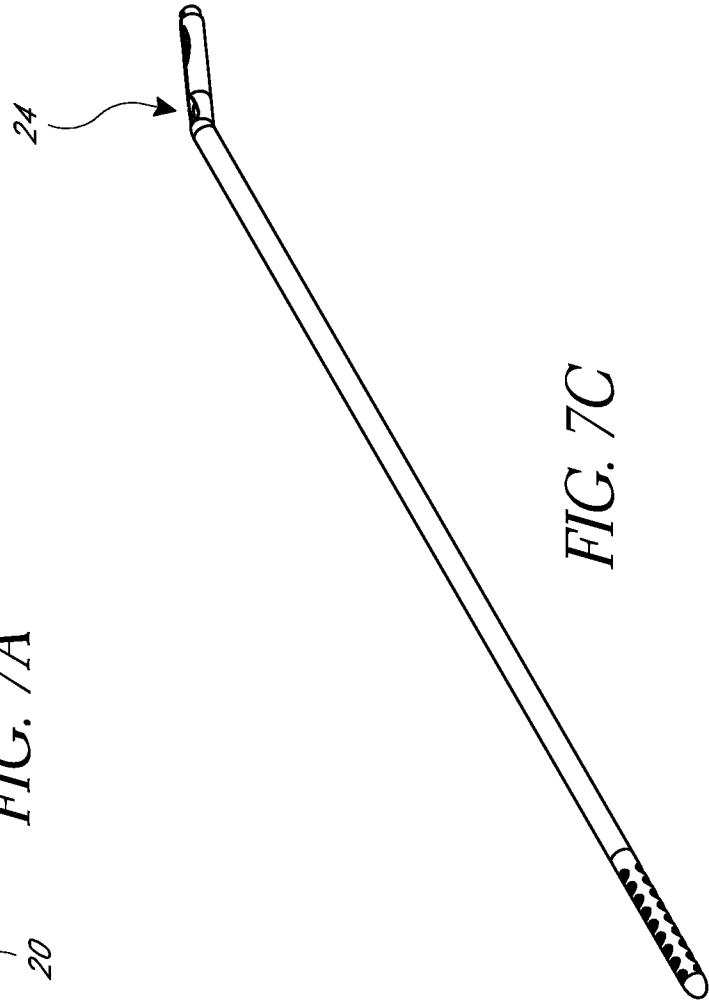
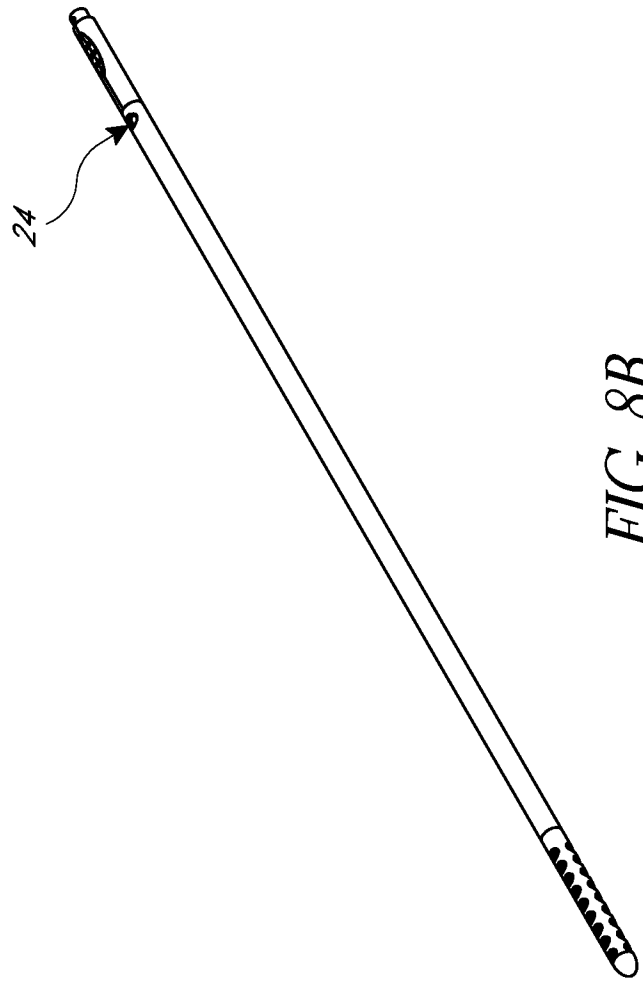
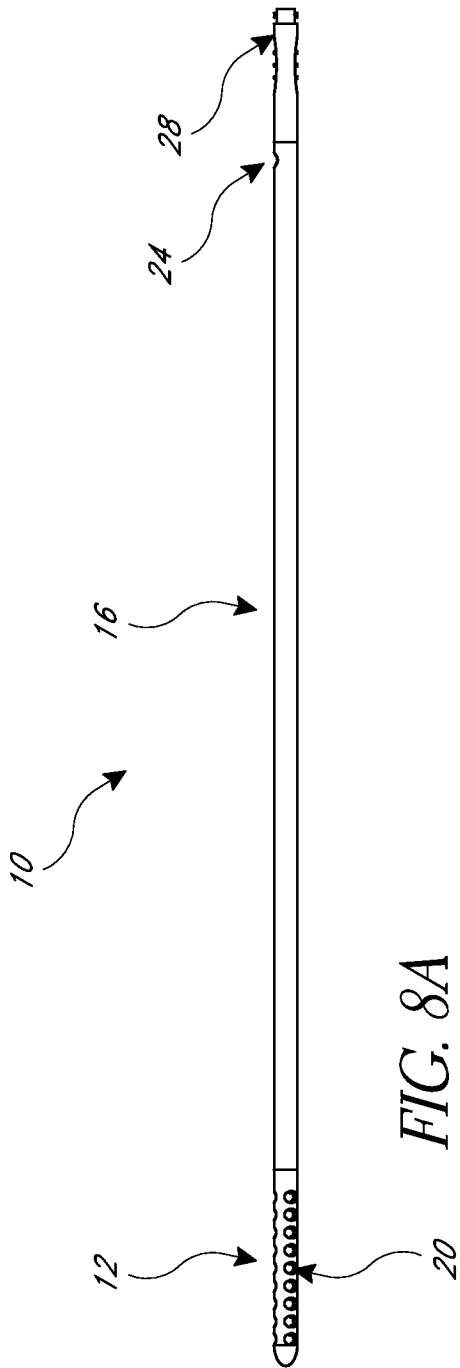

FIG. 7B





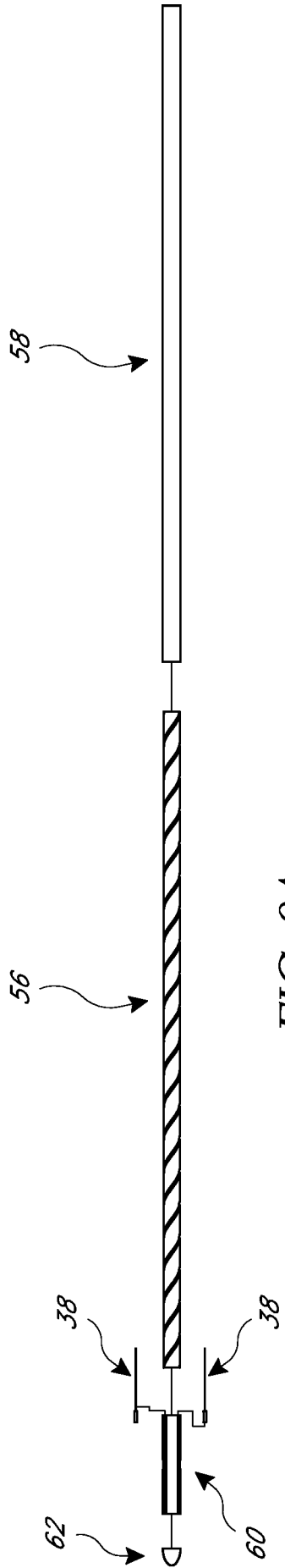

FIG. 9A

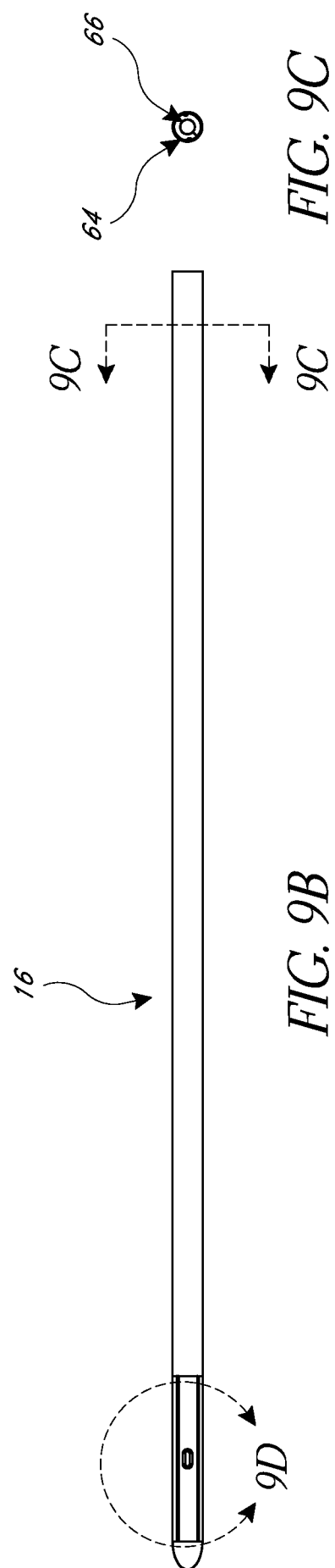
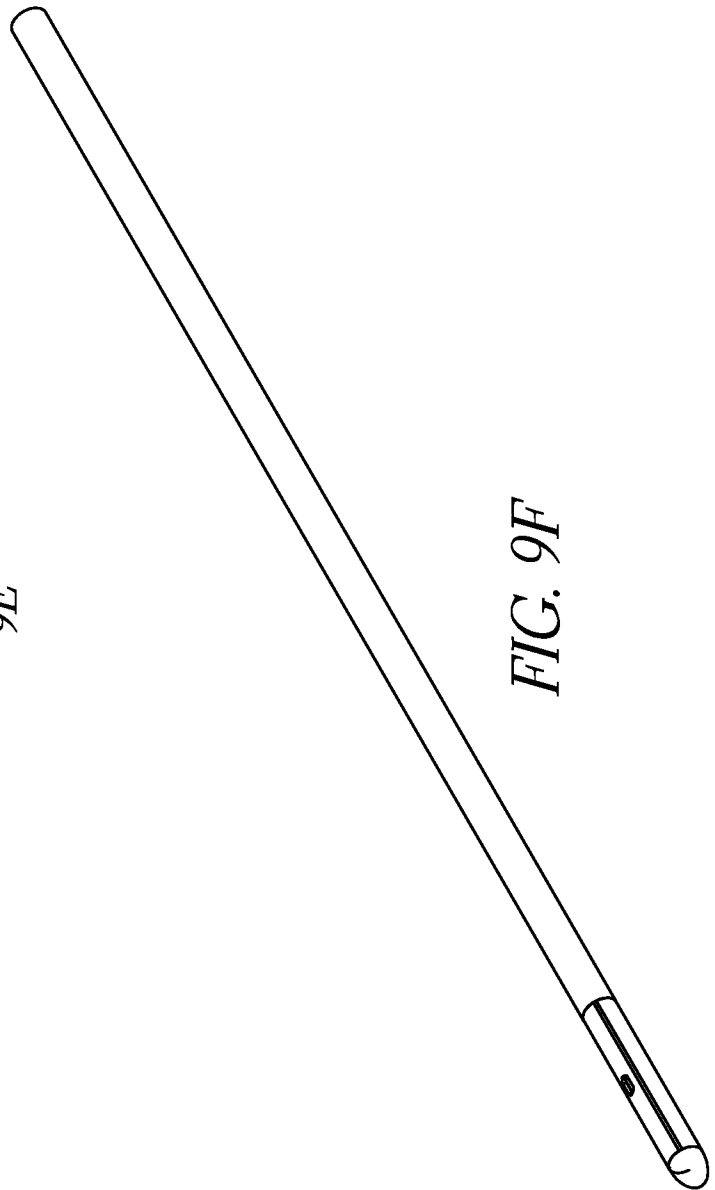
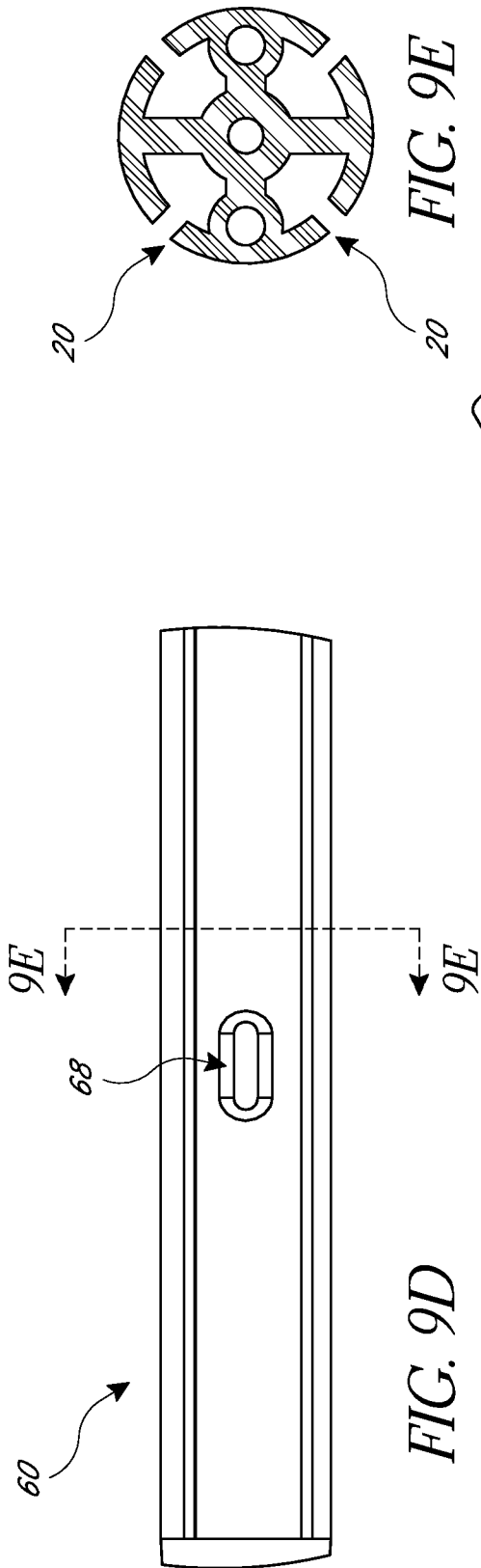

FIG. 9B

FIG. 9C



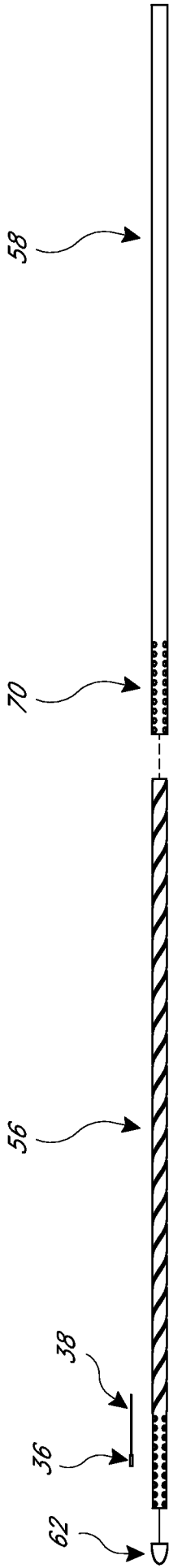

FIG. 10A

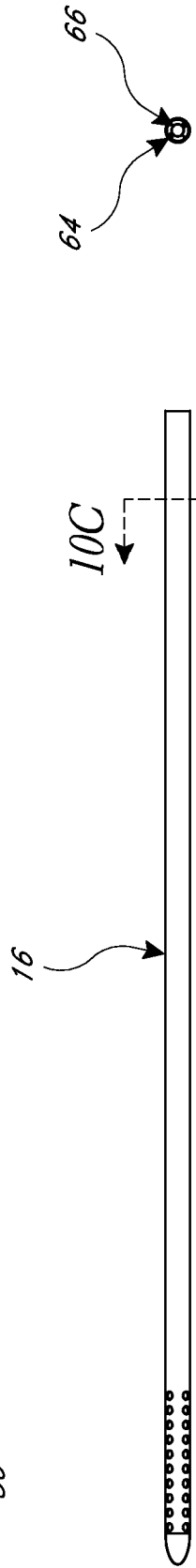

FIG. 10B

FIG. 10C

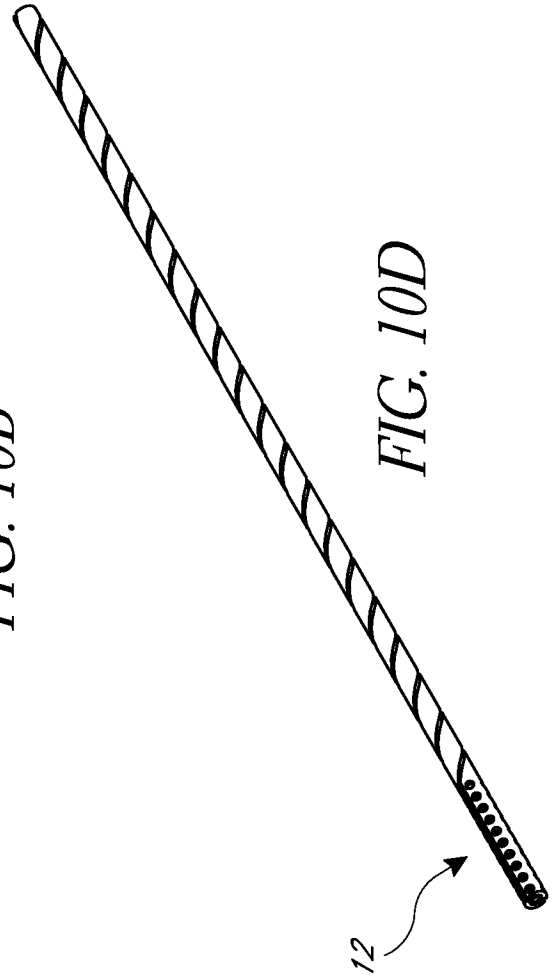
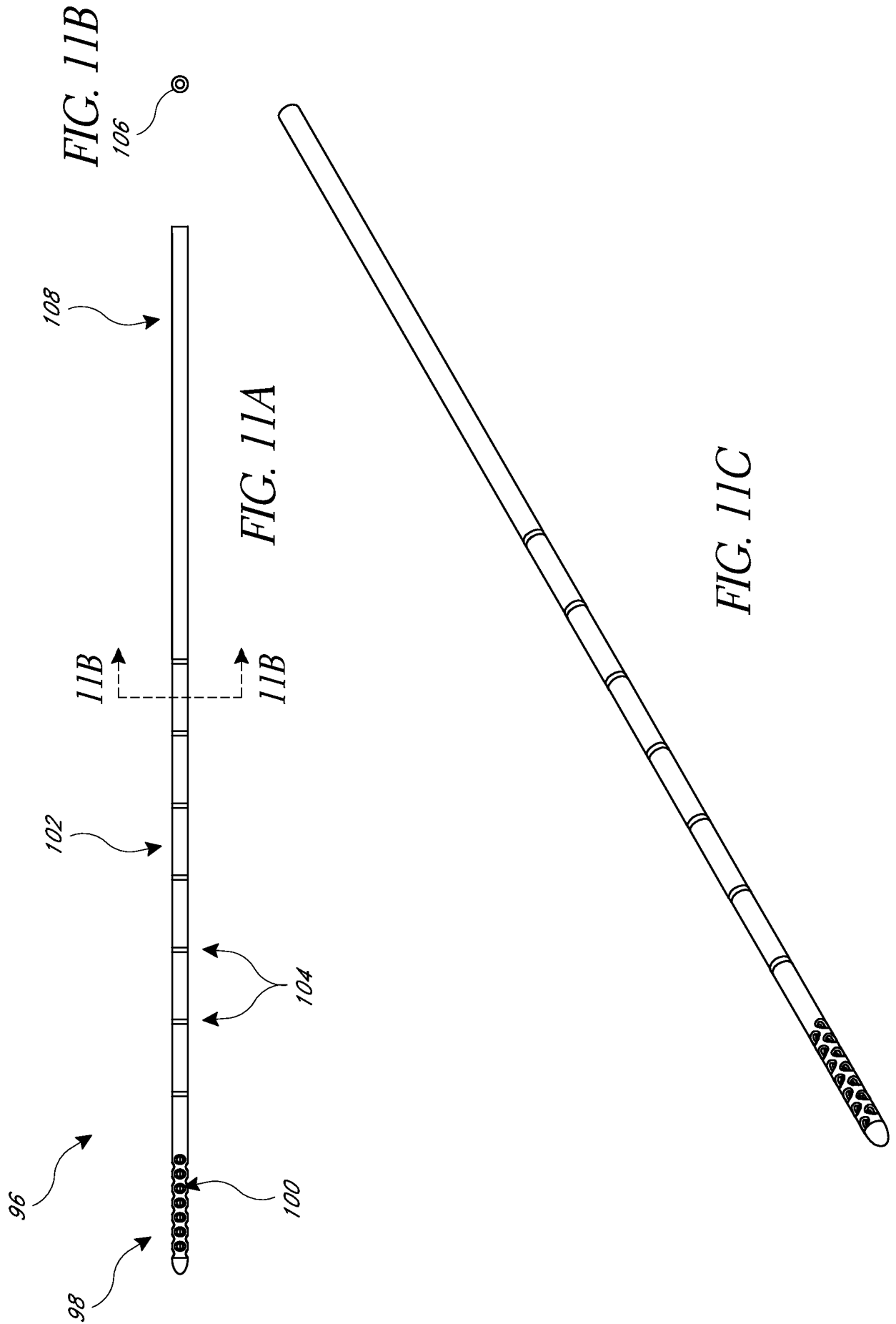

FIG. 10D



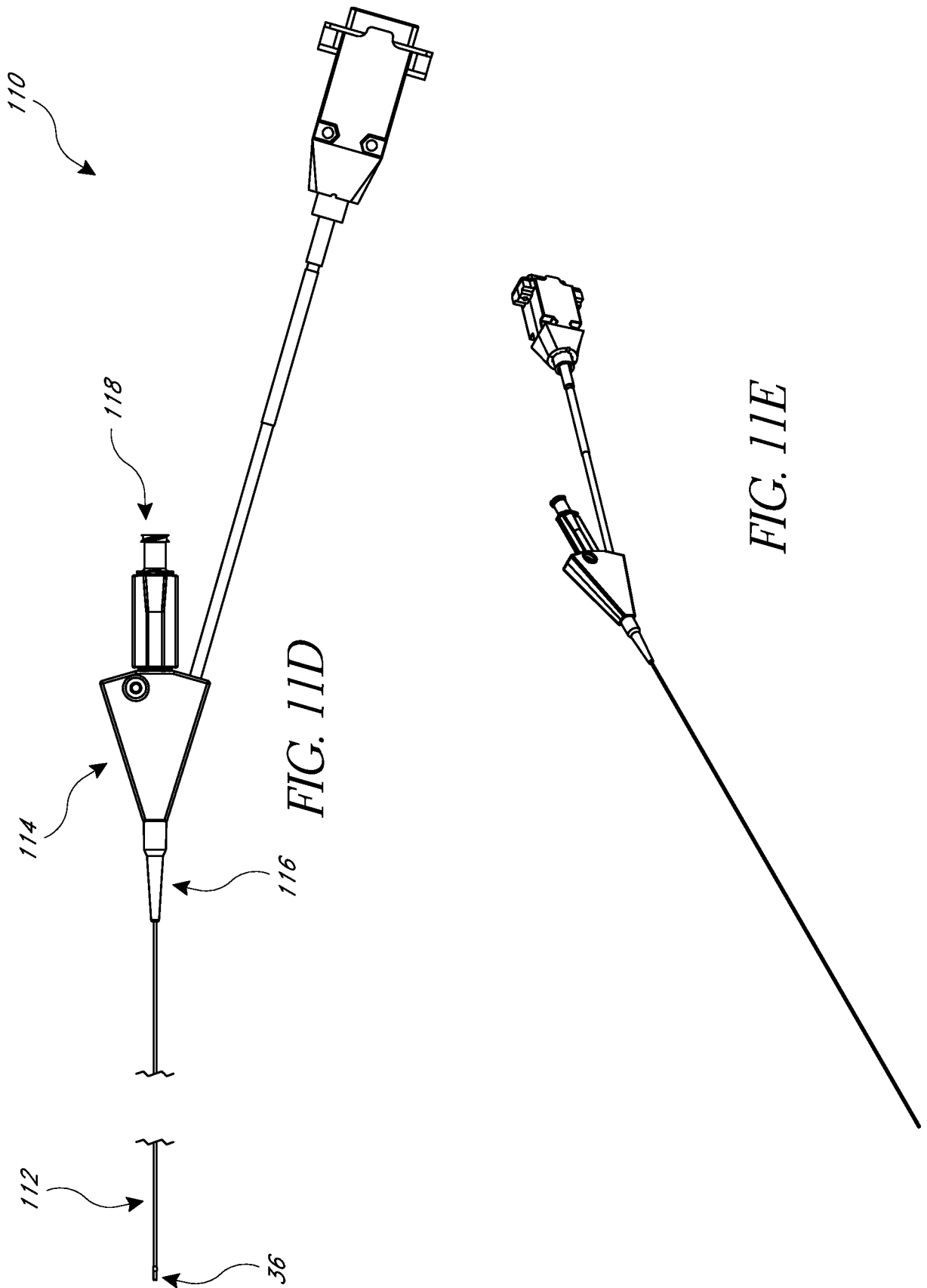
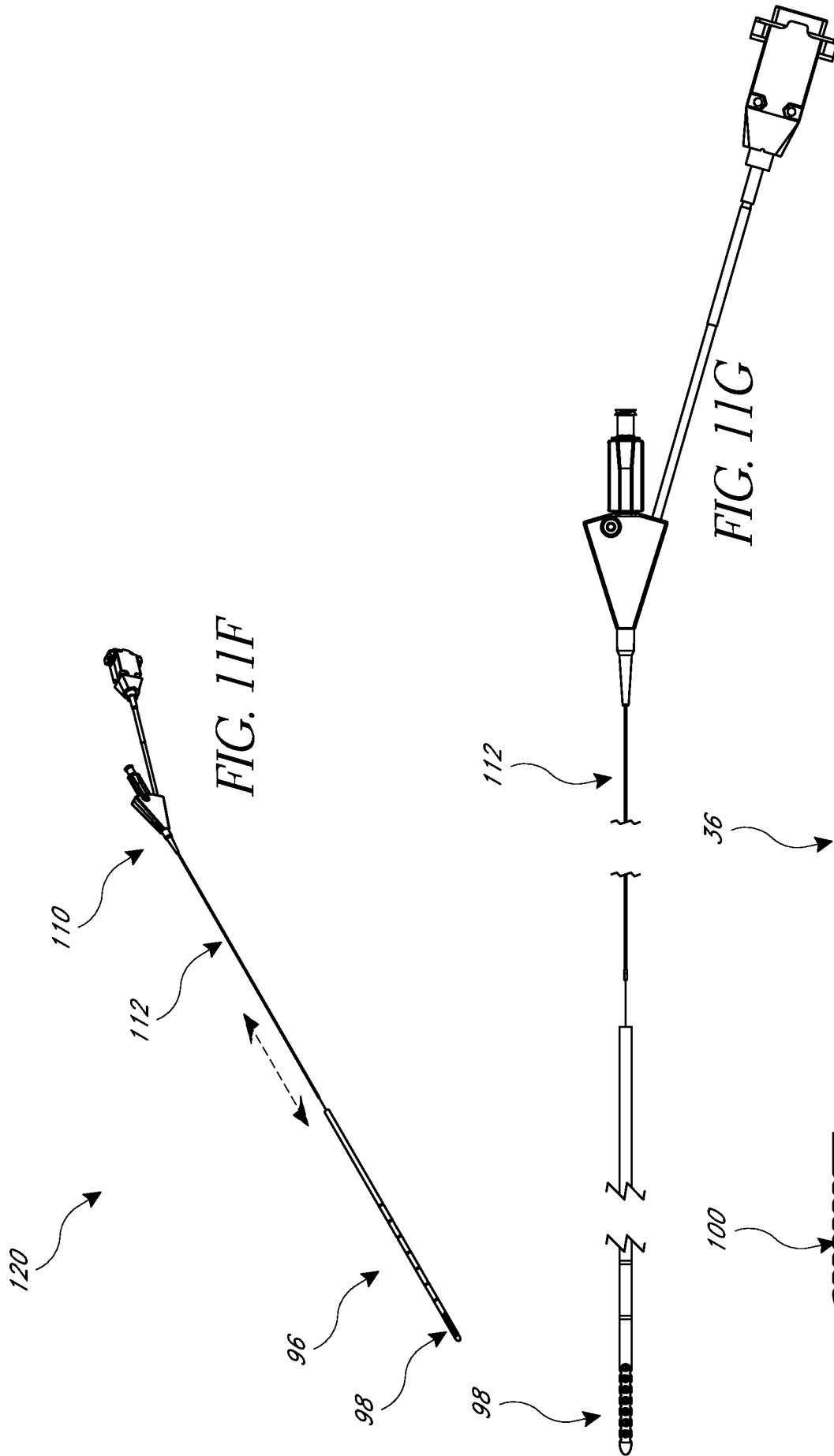

FIG. 11D

FIG. 11E



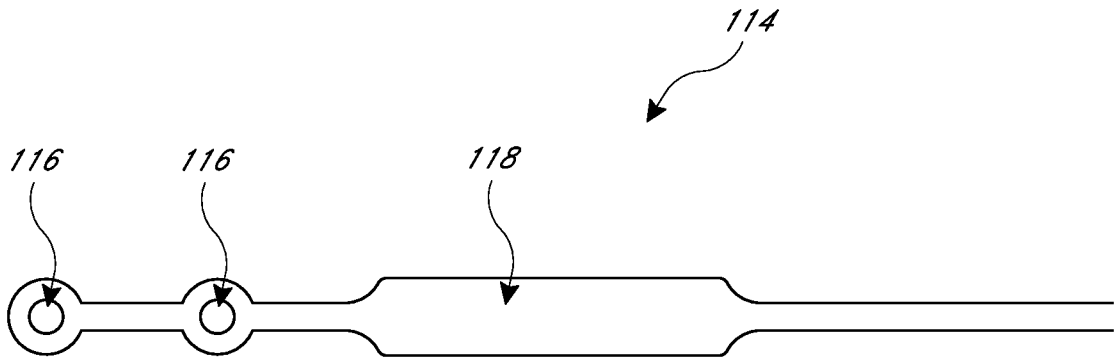

FIG. 12A

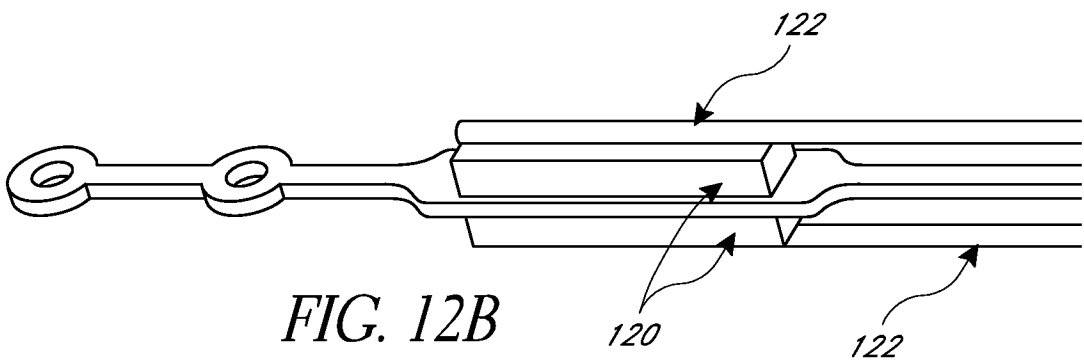

FIG. 12B

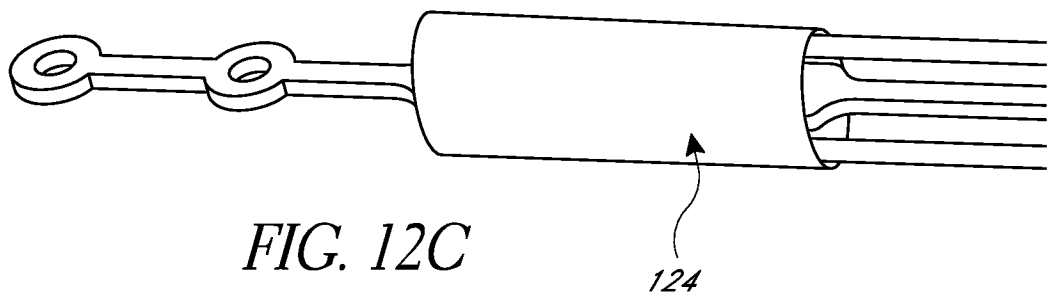

FIG. 12C

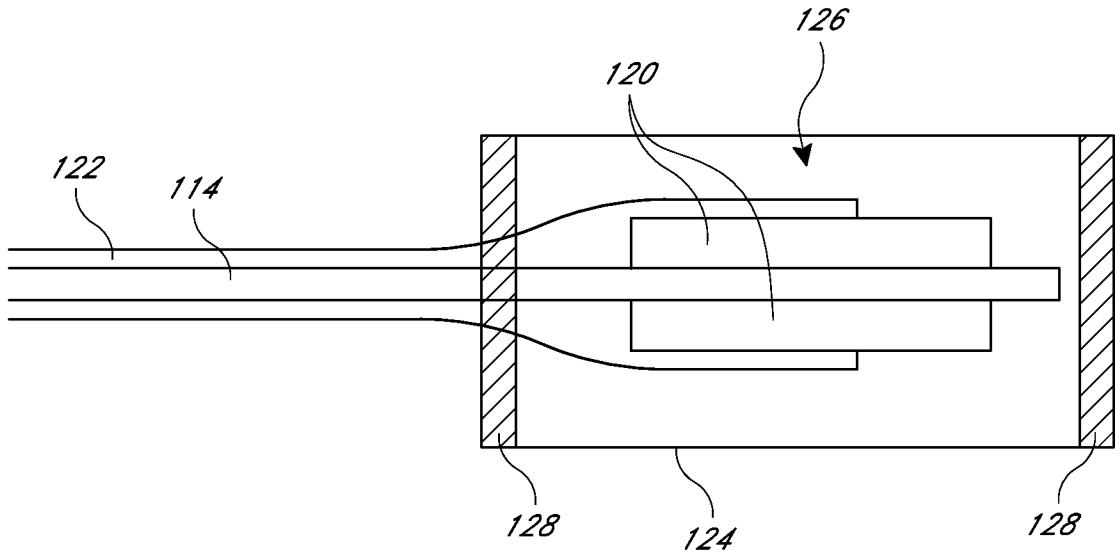

FIG. 13

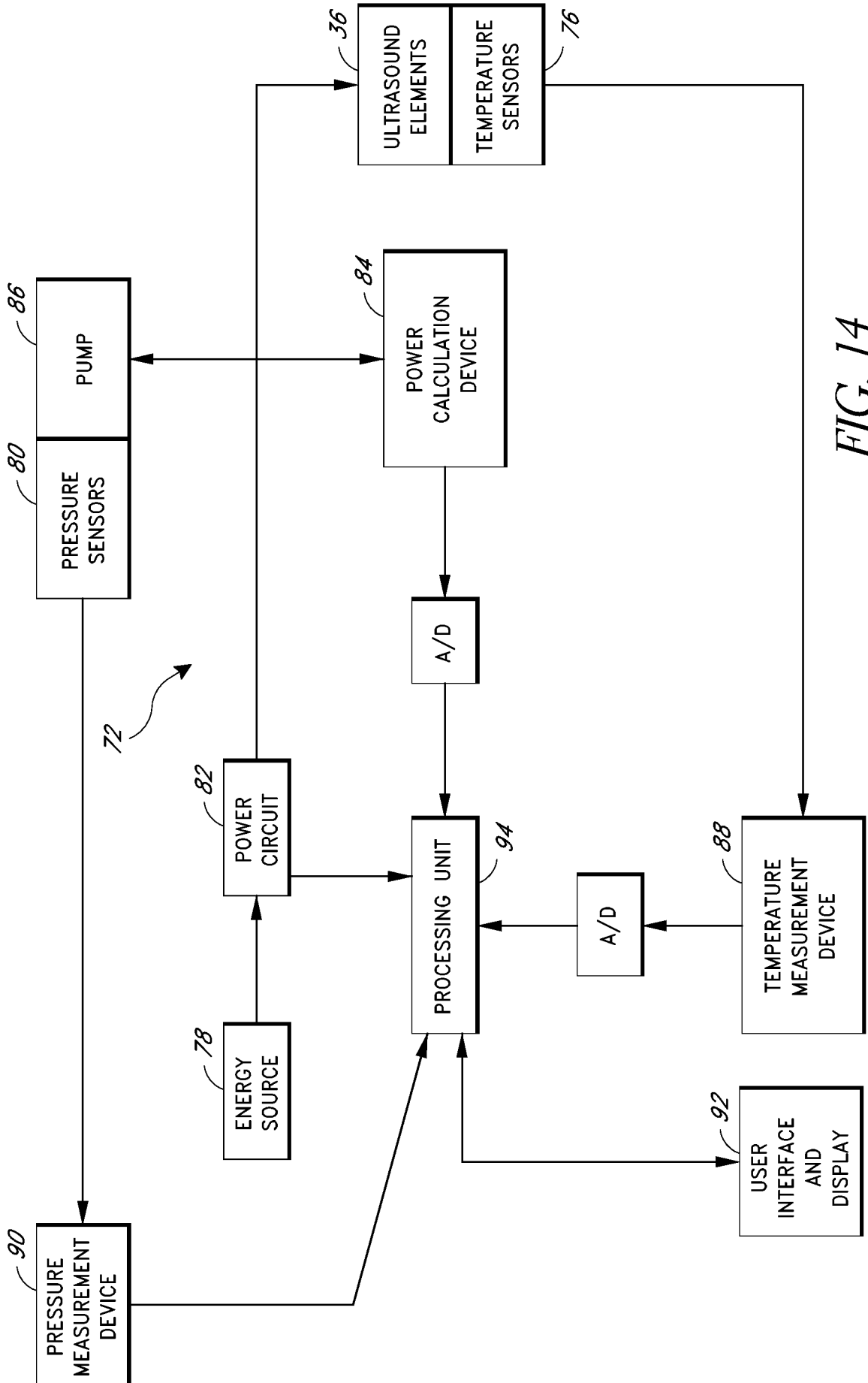

FIG. 14

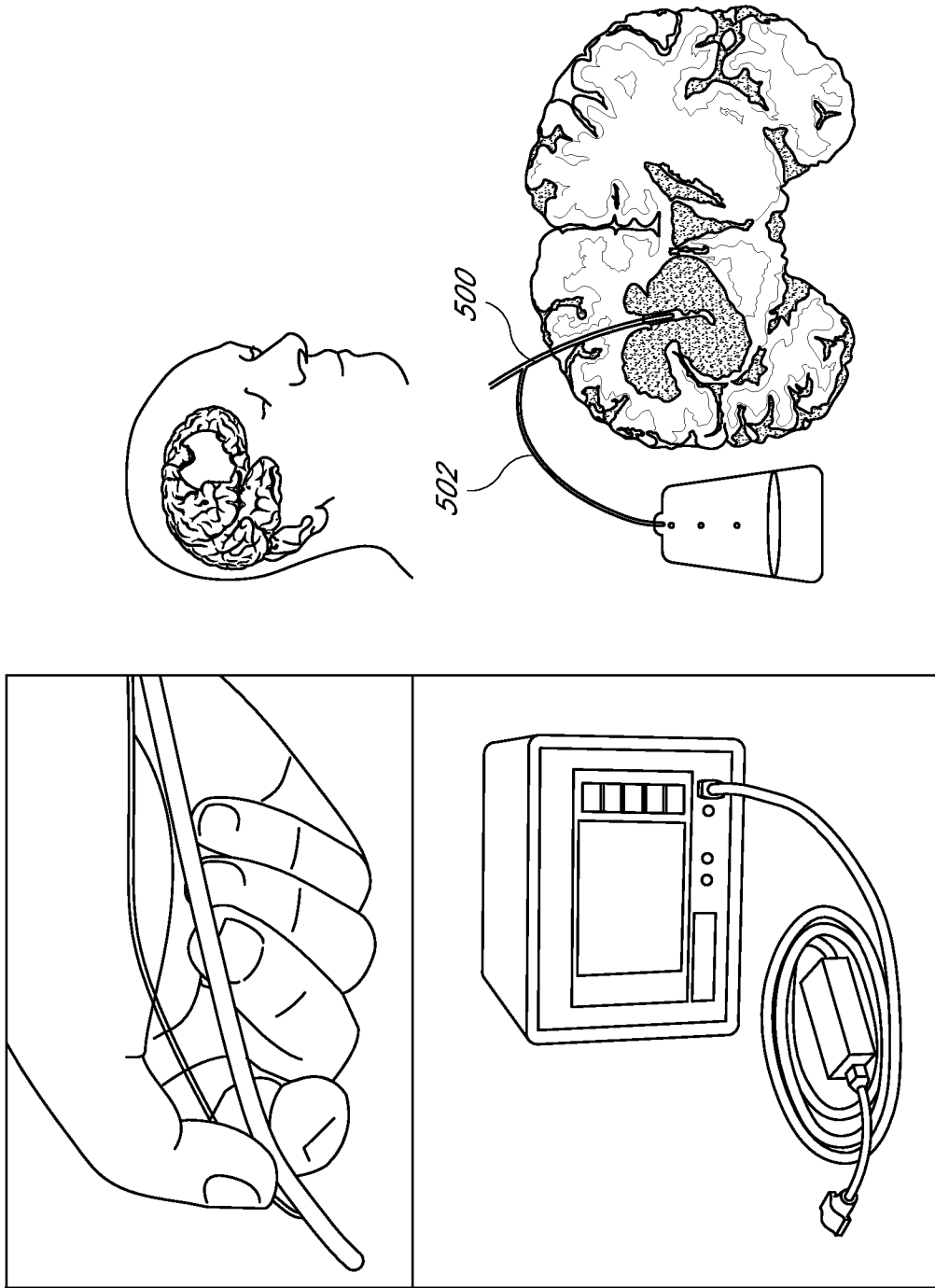

FIG. 15

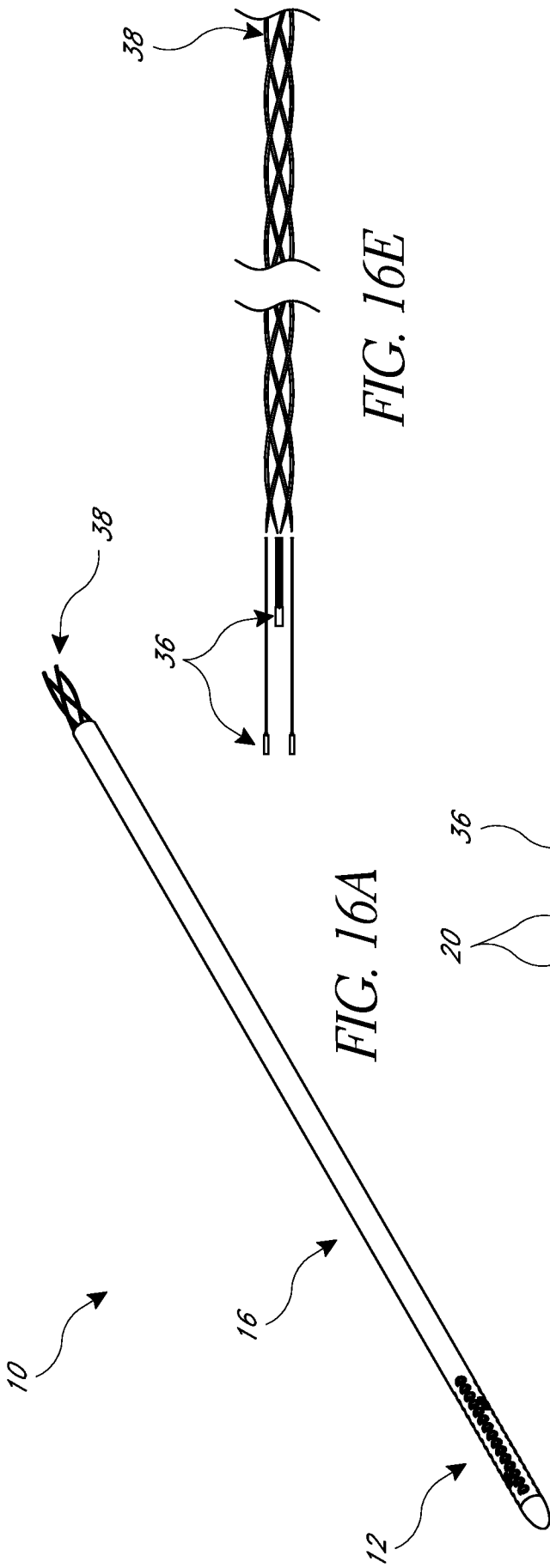

FIG. 16A

FIG. 16E

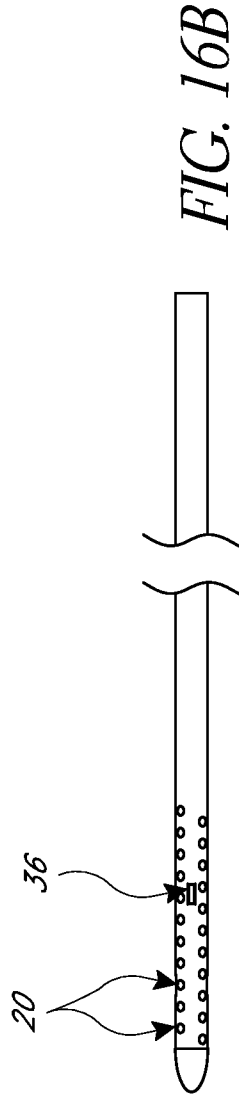

FIG. 16B

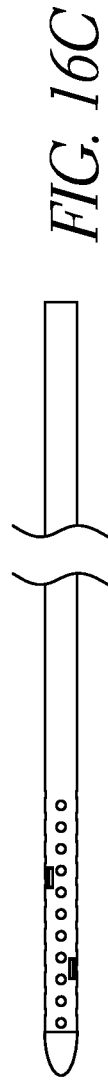

FIG. 16C

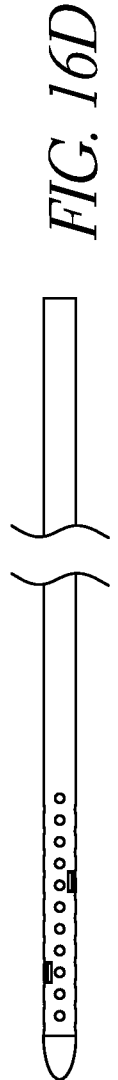

FIG. 16D

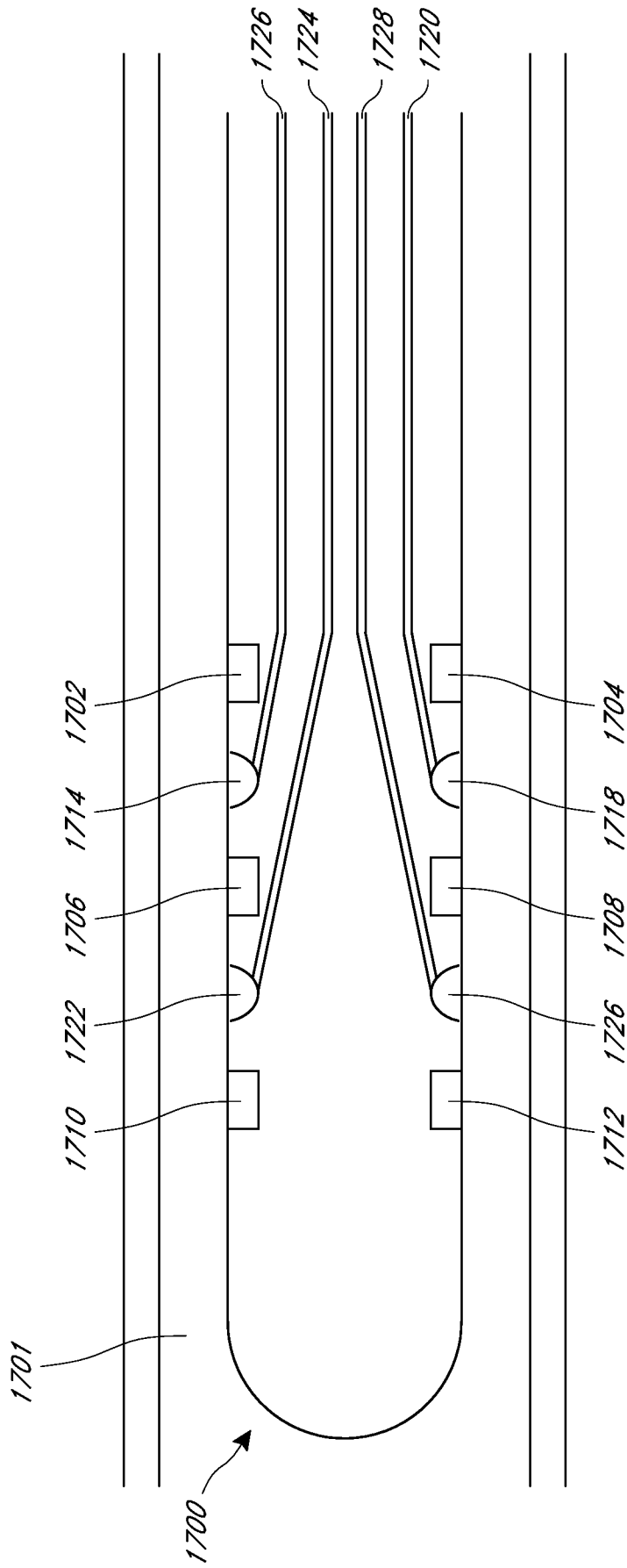

FIG. 17A

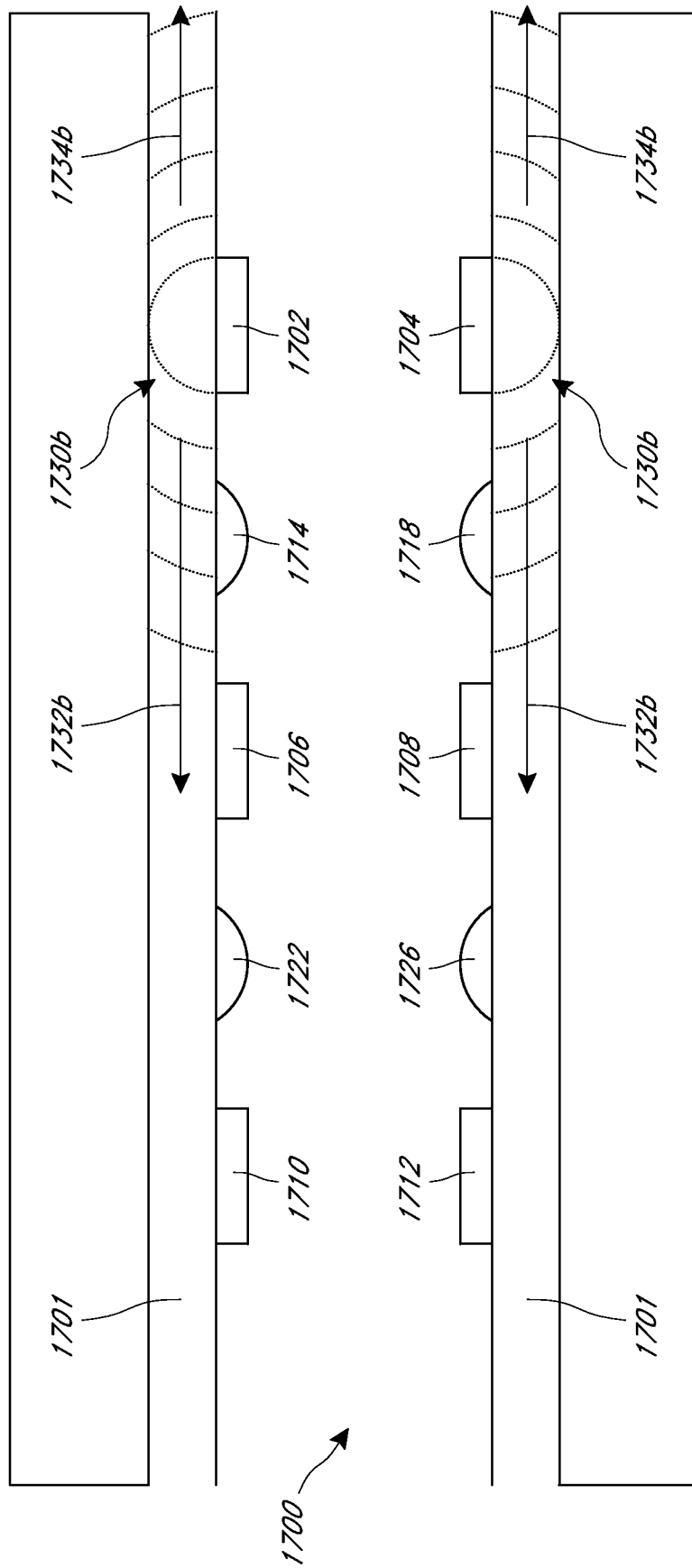

FIG. 17B

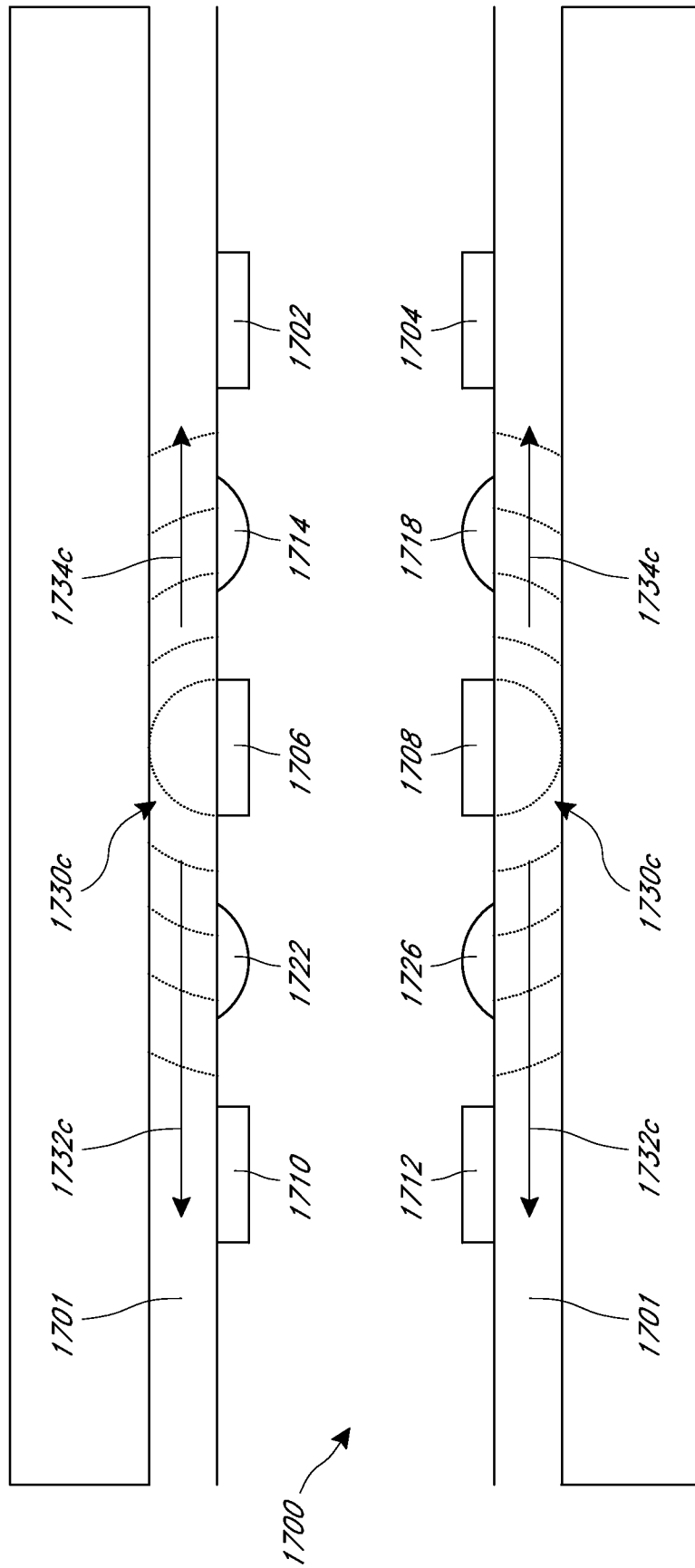

FIG. 17C

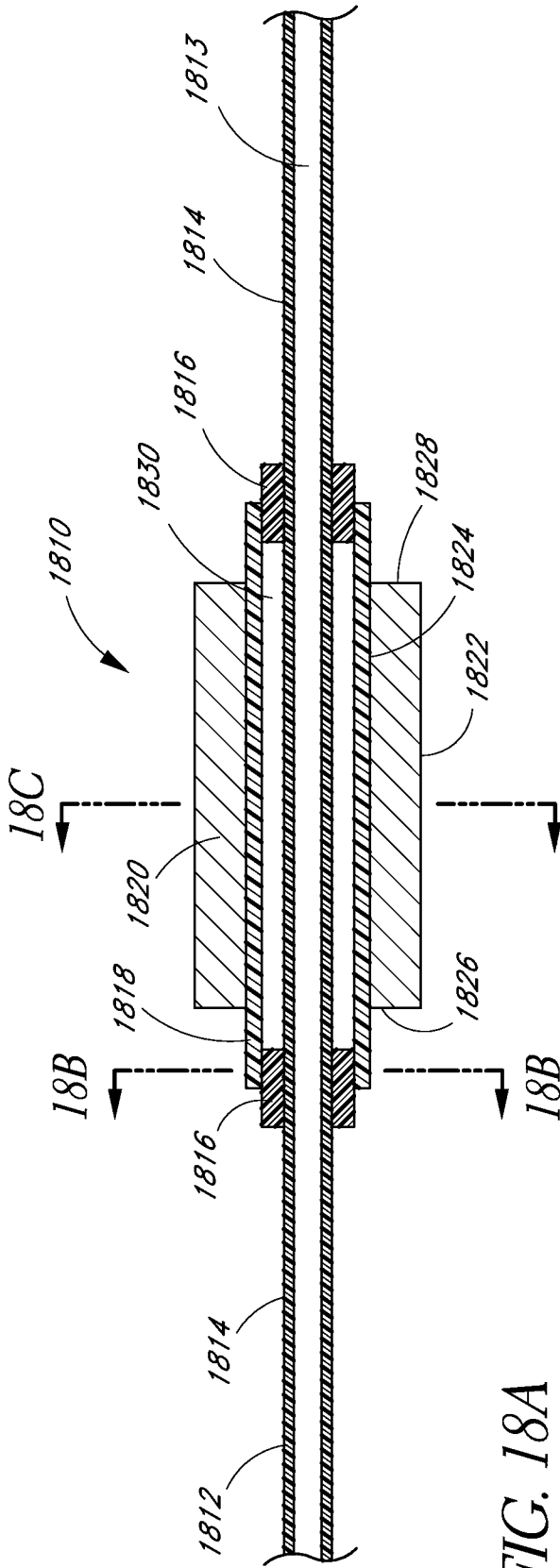

FIG. 18A

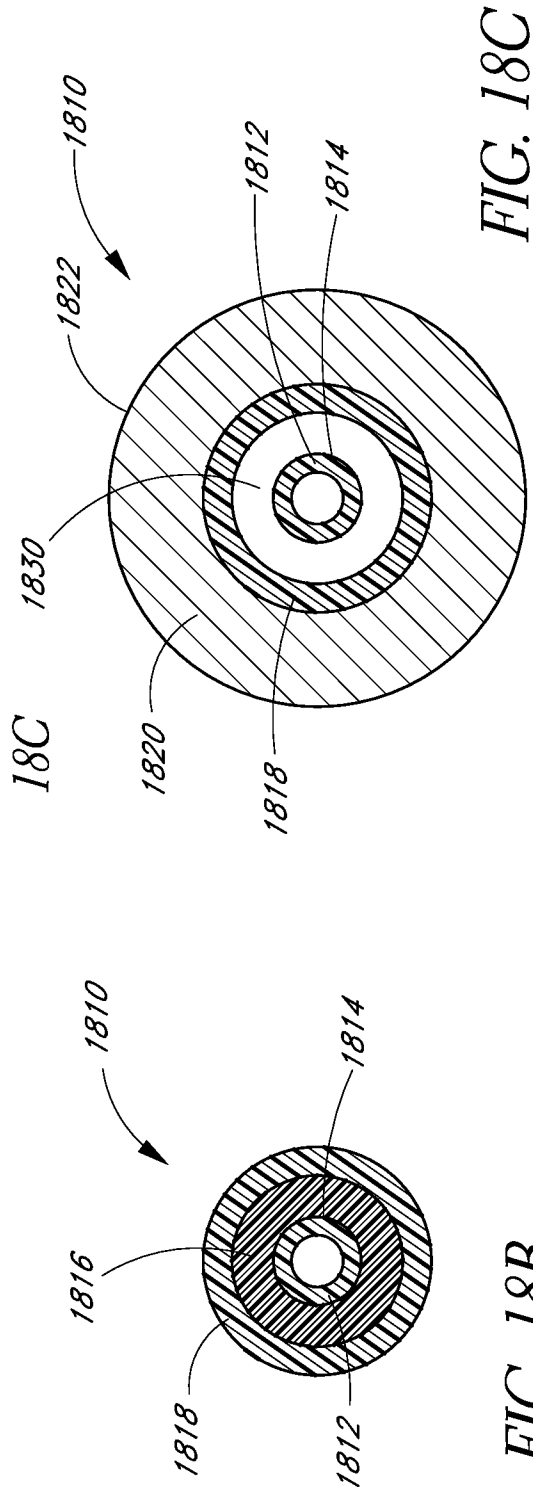

FIG. 18C

FIG. 18B

INTERNATIONAL SEARCH REPORT

International application No
PCT/US2014/022797

A. CLASSIFICATION OF SUBJECT MATTER
INV. A61M37/00 A61B17/22
ADD.
According to International Patent Classification (IPC) or to both national classification and IPC

B. FIELDS SEARCHED
Minimum documentation searched (classification system followed by classification symbols)
A61M A61B

Documentation searched other than minimum documentation to the extent that such documents are included in the fields searched

Electronic data base consulted during the international search (name of data base and, where practicable, search terms used)
EPO-Internal, WPI Data

C. DOCUMENTS CONSIDERED TO BE RELEVANT

Category*	Citation of document, with indication, where appropriate, of the relevant passages	Relevant to claim No.
X	US 2008/319376 A1 (WILCOX ROBERT L [US] ET AL) 25 December 2008 (2008-12-25) figures 1-7, 9, 11 paragraphs [0011], [0045] - [0046], [0054] - [0062], [0100] - [0102], [0109] -----	11-17
X	US 2012/209116 A1 (HOSSACK JOHN A [US] ET AL) 16 August 2012 (2012-08-16) figures 1,4,12 paragraphs [0036], [0164] - [0167], [0211] - [0216] -----	11-14
A	US 2012/059285 A1 (SOLTANI AZITA [US] ET AL) 8 March 2012 (2012-03-08) the whole document ----- -/--	11-17

Further documents are listed in the continuation of Box C.

See patent family annex.

* Special categories of cited documents :

- "A" document defining the general state of the art which is not considered to be of particular relevance
- "E" earlier application or patent but published on or after the international filing date
- "L" document which may throw doubts on priority claim(s) or which is cited to establish the publication date of another citation or other special reason (as specified)
- "O" document referring to an oral disclosure, use, exhibition or other means
- "P" document published prior to the international filing date but later than the priority date claimed

"T" later document published after the international filing date or priority date and not in conflict with the application but cited to understand the principle or theory underlying the invention

"X" document of particular relevance; the claimed invention cannot be considered novel or cannot be considered to involve an inventive step when the document is taken alone

"Y" document of particular relevance; the claimed invention cannot be considered to involve an inventive step when the document is combined with one or more other such documents, such combination being obvious to a person skilled in the art

"&" document member of the same patent family

Date of the actual completion of the international search 28 May 2014	Date of mailing of the international search report 16/06/2014
--	--

Name and mailing address of the ISA/ European Patent Office, P.B. 5818 Patentlaan 2 NL - 2280 HV Rijswijk Tel. (+31-70) 340-2040, Fax: (+31-70) 340-3016	Authorized officer Friedrich, Franz
--	--

INTERNATIONAL SEARCH REPORT

International application No
PCT/US2014/022797

C(Continuation). DOCUMENTS CONSIDERED TO BE RELEVANT		
Category*	Citation of document, with indication, where appropriate, of the relevant passages	Relevant to claim No.
A	US 5 630 837 A (CROWLEY ROBERT J [US]) 20 May 1997 (1997-05-20) figures 1,2,4-6,9 column 1, line 38 - line 61 column 2, line 38 - line 56 column 3, line 48 - column 5, line 56 column 6, line 26 - line 47 -----	11,15-17

INTERNATIONAL SEARCH REPORT

International application No.
PCT/US2014/022797

Box No. II Observations where certain claims were found unsearchable (Continuation of item 2 of first sheet)

This international search report has not been established in respect of certain claims under Article 17(2)(a) for the following reasons:

1. Claims Nos.: 1-10
because they relate to subject matter not required to be searched by this Authority, namely:
see FURTHER INFORMATION sheet PCT/ISA/210
2. Claims Nos.:
because they relate to parts of the international application that do not comply with the prescribed requirements to such an extent that no meaningful international search can be carried out, specifically:
3. Claims Nos.:
because they are dependent claims and are not drafted in accordance with the second and third sentences of Rule 6.4(a).

Box No. III Observations where unity of invention is lacking (Continuation of item 3 of first sheet)

This International Searching Authority found multiple inventions in this international application, as follows:

1. As all required additional search fees were timely paid by the applicant, this international search report covers all searchable claims.
2. As all searchable claims could be searched without effort justifying an additional fees, this Authority did not invite payment of additional fees.
3. As only some of the required additional search fees were timely paid by the applicant, this international search report covers only those claims for which fees were paid, specifically claims Nos.:
4. No required additional search fees were timely paid by the applicant. Consequently, this international search report is restricted to the invention first mentioned in the claims; it is covered by claims Nos.:

Remark on Protest

- The additional search fees were accompanied by the applicant's protest and, where applicable, the payment of a protest fee.
- The additional search fees were accompanied by the applicant's protest but the applicable protest fee was not paid within the time limit specified in the invitation.
- No protest accompanied the payment of additional search fees.

FURTHER INFORMATION CONTINUED FROM PCT/ISA/ 210

Continuation of Box II.1

Claims Nos.: 1-10

Pursuant to Article 17(2)(a)(i) and Rule 39.1(iv) PCT, the subject-matter of claim 1 has not been searched, since it is directed to a method for treatment of the human body by surgery. In fact the, method disclosed by claim 1 comprises "delivering compounds to a target region" as well as "introducing a first therapeutic compound to the target location". In view of the accompanying description, in particular paragraph 0071, it is clear that the target region/located is situated within the human body and that the claimed method is thus an invasive method for treatment of the human body. Thus, no examination is carried out for claim 1 (Article 34(4)(a)(i) and Rule 67.1(iv) PCT). Claims 2 to 10 being dependent on claim 1 have furthermore not examined for the same reasons.

INTERNATIONAL SEARCH REPORT

Information on patent family members

International application No PCT/US2014/022797

Patent document cited in search report	Publication date	Patent family member(s)	Publication date	
US 2008319376	A1	25-12-2008	EP 2170181 A1	07-04-2010
			EP 2494932 A2	05-09-2012
			US 2008319376 A1	25-12-2008
			US 2013211316 A1	15-08-2013
			WO 2009002881 A1	31-12-2008

US 2012209116	A1	16-08-2012	EP 2456369 A1	30-05-2012
			JP 2013500067 A	07-01-2013
			US 2012209116 A1	16-08-2012
			WO 2011011539 A1	27-01-2011

US 2012059285	A1	08-03-2012	CN 103228224 A	31-07-2013
			EP 2608730 A2	03-07-2013
			JP 2013538097 A	10-10-2013
			US 2012059285 A1	08-03-2012
			WO 2012027722 A2	01-03-2012

US 5630837	A	20-05-1997	AU 5382296 A	16-10-1996
			EP 0764004 A1	26-03-1997
			JP 3853364 B2	06-12-2006
			JP H10502290 A	03-03-1998
			US 5630837 A	20-05-1997
			WO 9629935 A1	03-10-1996
