



(51) International Patent Classification:

A47L 13/17 (2006.01) A47L 13/256 (2006.01)

(21) International Application Number:

PCT/US2017/064998

(22) International Filing Date:

07 December 2017 (07.12.2017)

(25) Filing Language:

English

(26) Publication Language:

English

(30) Priority Data:

62/431,555 08 December 2016 (08.12.2016) US

(71) Applicant: **THE PROCTER & GAMBLE COMPANY** [US/US]; One Procter & Gamble Plaza, Cincinnati, Ohio 45202 (US).

(72) Inventors: **SONG, Cunming**; One Procter & Gamble Plaza, Cincinnati, Ohio 45202 (US). **BAO, Hailing**; One Procter & Gamble Plaza, Cincinnati, Ohio 45202 (US). **DE BEER, Antonius, Lambertus**; One Procter & Gamble Plaza, Cincinnati, Ohio 45202 (US).

(74) Agent: **KREBS, Jay A.**; c/o THE PROCTER & GAMBLE COMPANY, Global IP Services, One Procter & Gamble Plaza, C9, Cincinnati, Ohio 45202 (US).

(81) Designated States (unless otherwise indicated, for every kind of national protection available): AE, AG, AL, AM, AO, AT, AU, AZ, BA, BB, BG, BH, BN, BR, BW, BY, BZ, CA, CH, CL, CN, CO, CR, CU, CZ, DE, DJ, DK, DM, DO, DZ, EC, EE, EG, ES, FI, GB, GD, GE, GH, GM, GT, HN, HR, HU, ID, IL, IN, IR, IS, JO, JP, KE, KG, KH, KN, KP, KR, KW, KZ, LA, LC, LK, LR, LS, LU, LY, MA, MD, ME, MG, MK, MN, MW, MX, MY, MZ, NA, NG, NI, NO, NZ, OM, PA, PE, PG, PH, PL, PT, QA, RO, RS, RU, RW, SA,

SC, SD, SE, SG, SK, SL, SM, ST, SV, SY, TH, TJ, TM, TN, TR, TT, TZ, UA, UG, US, UZ, VC, VN, ZA, ZM, ZW.

(84) Designated States (unless otherwise indicated, for every kind of regional protection available): ARIPO (BW, GH, GM, KE, LR, LS, MW, MZ, NA, RW, SD, SL, ST, SZ, TZ, UG, ZM, ZW), Eurasian (AM, AZ, BY, KG, KZ, RU, TJ, TM), European (AL, AT, BE, BG, CH, CY, CZ, DE, DK, EE, ES, FI, FR, GB, GR, HR, HU, IE, IS, IT, LT, LU, LV, MC, MK, MT, NL, NO, PL, PT, RO, RS, SE, SI, SK, SM, TR), OAPI (BF, BJ, CF, CG, CI, CM, GA, GN, GQ, GW, KM, ML, MR, NE, SN, TD, TG).

Published:

— with international search report (Art. 21(3))

(54) Title: CLEANING PAD WITH SPLIT CORE FIBROUS STRUCTURES

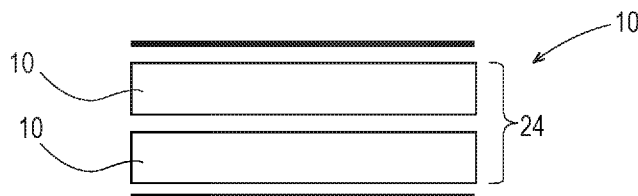

Fig. 2

(57) Abstract: A cleaning pad exhibiting a basis weight of at least 100 gsm, wherein the cleaning pad comprises two or more fibrous structure plies (10) comprising pulp fibers, wherein each of the fibrous structure plies exhibits a basis weight of less than 250 gsm and at least one of the fibrous structure plies exhibits a basis weight of greater than 70 gsm to less than 250 gsm. Furthermore a cleaning system wherein the cleaning pad is attached to an implement is provided.



CLEANIN PAD WITH SPLIT CORE FIBROUS STRUCTURES

FIELD OF THE INVENTION

The present invention relates to split core fibrous structures, more particular cleaning pads, such as pre-moistened floor cleaning pads, that are suitable for attachment to an implement, such as a cleaning pad holder and handle, wherein the cleaning pads comprise a split core fibrous structure, and methods for making same.

BACKGROUND OF THE INVENTION

Pre-moistened cleaning pads, for example pre-moistened floor cleaning pads, comprising a liquid composition are known in the art. However, such known pre-moistened fibrous structures exhibit compositions and/or physical structures and/or physical properties that cause the pre-moistened fibrous structures to dump and/or lose their liquid compositions and then usefulness too early in the cleaning process for consumers of such pre-moistened cleaning pads. In other words, known pre-moistened cleaning pads exhibit lower mileage than desired by consumers.

As shown in Prior Art Fig. 1, formulators have added more pulp fibers and basis weight in the core component of the cleaning pads to increase capacity and/or mileage. Prior Art Fig. 1 is an example of a prior art cleaning pad 10 comprising a single pulp fiber-containing fibrous structure core component 24 sandwiched between two scrim components 26. The problem experienced with such single core component cleaning pads is that formulators are limited by the upper basis weight of the single core component. In this case, the single core component exhibited a basis weight of over 130 gsm. The problem is that as the core component's basis weight increases, especially those core components that comprise pulp fibers, their tendency to shear during use, such as during pushing on a floor by a consumer, increases.

One problem with known pre-moistened cleaning pads is single core component cleaning pads with a high basis weight pulp fiber-containing fibrous structure single core component shear during use. It is believed that one reason for this shearing is the lack of bonding the high basis weight pulp fiber-containing fibrous structure single core component.

In light of the foregoing, there is a need for cleaning pads, for example pre-moistened cleaning pads, that overcome the negatives associated with the high basis weight pulp-containing fibrous structure single core component.

SUMMARY OF THE INVENTION

The present invention relates to a cleaning pad, for example a pre-moistened cleaning pad, that comprises a split core component comprising two or more pulp fiber-containing fibrous structures.

One solution to the problem is to produce a cleaning pad comprising two or more pulp
5 fiber-containing fibrous structures that exhibit basis weights of less than 250 gsm and/or less than 200 gsm and/or less than 175 gsm and/or less than 150 gsm and/or less than 130 gsm and/or less than 120 gsm.

In one example, a cleaning pad exhibiting a basis weight of at least 100 gsm, wherein the cleaning pad comprises two or more fibrous structure plies comprising pulp fibers, wherein each of the fibrous structure plies exhibits a basis weight of less than 250 gsm and at least one of the fibrous structure plies exhibits a basis weight of greater than 70 gsm to less than 250 gsm, is provided.

The present invention provides cleaning pads comprising a split core component, method for making such novel pre-moistened cleaning pads, and methods for using such novel pre-moistened cleaning pads.

BRIEF DESCRIPTION OF THE DRAWINGS

Fig. 1A is a schematic representation of a prior art cleaning pad comprising a single core
10 component;

Fig. 2 is a schematic representation of an example of a cleaning pad according to the present invention;

Fig. 3 is a schematic representation of another example of a cleaning pad according to the present invention;

Fig. 4 is a schematic representation of another example of a cleaning pad according to the
15 present invention;

Fig. 5 is a schematic representation of another example of a cleaning pad according to the present invention;

Fig. 6A is a schematic representation of a pre-moistened cleaning pad on an implement
20 according to the present invention;

Fig. 6B is a cross-sectional view of the pre-moistened cleaning pad and implement according to the present invention taken along line 6A-6A;

Fig. 7 is a schematic representation of an example of a method for making a fibrous structure suitable for use in a cleaning pad according to the present invention;

Fig. 8 is a top plan view of a die suitable for use in the method of the present invention;

25

Fig. 9 is a magnified view of a portion of the die of Fig. 7;

Fig. 10 are images of the mopping head apparatus used in the Mileage Test Method;

Fig. 11 is the pattern for mopping used in the Mileage Test Method; and

Fig. 12 is an array of images showing streak levels for the Mileage Test Method.

5

DETAILED DESCRIPTION OF THE INVENTION

Definitions

“Fibrous structure” as used herein means a structure that comprises a plurality of filaments and/or a plurality of solid additives, such as fibers, for example pulp fibers, for example wood pulp fibers, and/or particles, such as superabsorbent materials. In one example, a fibrous structure according to the present invention means an orderly arrangement of filaments and fibers within a structure in order to perform a function. In another example, a fibrous structure according to the present invention is a nonwoven.

The cleaning pad may comprise a fibrous structure, for example a unitary fibrous structure, that is designed to have two or more different portions that perform different functions, for example part of the fibrous structure may be designed to perform the functions of the attachment portion of the pre-moistened cleaning pad and another part of the fibrous structure may be designed to perform the functions of the cleaning portion of the pre-moistened cleaning pad. Optionally, the fibrous structure may further include a part that is designed to perform the functions of the edge portion of the pre-moistened cleaning pad. The fibrous structure and/or portions thereof may comprise one or more fibrous structures, such as plies and/or layers, that are associated with one another to form the cleaning pad and/or portions, such as the attachment portion, cleaning portion, and optionally the edge portion, of the cleaning pad.

Non-limiting examples of processes for making fibrous structures include meltblowing and/or spunbonding processes. In one example, the fibrous structures of the present invention are made via a process comprising meltblowing. In another example, the fibrous structures of the present invention are made by meltblowing and coforming (mixing a plurality of filaments, such as meltblown and/or spunbond, for example meltblown filaments with a plurality of solid additives, such as fibers, for example pulp fibers such as wood pulp fibers, and collecting the mixture on a collection device to form a co-formed fibrous structure).

The fibrous structures of the different portions of the pre-moistened cleaning pads of the present invention may comprise different surfaces, for example: 1) a fibrous structure surface; 2) a protruding surface (macro protrusion surface); and 3) a contact surface (micro protrusion surface). Each of the surfaces exhibits a surface area, for example the fibrous structure surface

exhibits a fibrous structure surface area, the protruding surface (macro protrusion surface) exhibits a protruding surface (macro protrusion surface) surface area (macro protrusion surface area), and the contact surface (micro protrusion surface) exhibits a contact surface (micro protrusion surface) surface area (micro protrusion surface area). The at least three surfaces and/or surface areas of the surfaces may be identified visually since they will be visually discernible and/or with or without the aid of cross-sectional images of the fibrous structures.

The fibrous structures of the present invention may be homogeneous or may be layered. If layered, the fibrous structures may comprise at least two and/or at least three and/or at least four and/or at least five layers.

The fibrous structures of the present invention may be co-formed fibrous structures.

In one example, the fibrous structure, for example the pre-moistened fibrous structure, is a saleable unit and/or a useable unit in a form and/or shape that a consumer purchases and/or uses.

“Co-formed fibrous structure” as used herein means that the fibrous structure comprises a mixture of at least two different materials wherein at least one of the materials, for example a first material, comprises filaments, such as polypropylene filaments, and at least one other material, for example a second material, different from the first material, comprises solid additives, such as pulp fibers and/or particulates. In one example, a co-formed fibrous structure comprises solid additives, such as pulp fibers, such as wood pulp fibers, and filaments, such as polypropylene filaments that are commingled together.

“Solid additive” as used herein means a pulp fiber and/or a particulate.

“Particulate” as used herein means a granular substance or powder. In one example, the particulate comprises superabsorbent material particles.

“Filament” as used herein means an elongate particulate having an apparent length greatly exceeding its apparent width, i.e. a length to diameter ratio of at least about 10. A filament is made via spinning, for example via meltblowing and/or spunbonding, from a polymer, for example a thermoplastic polymer, such as polyolefin, for example polypropylene and/or polyethylene, and/or polyester. A filament” is an elongate particulate as described above that exhibits a length of greater than or equal to 5.08 cm (2 in.). Filaments are typically considered continuous or substantially continuous in nature. Non-limiting examples of filaments include meltblown and/or spunbond filaments. Non-limiting examples of materials that can be spun into filaments include thermoplastic polymer filaments, such as polyesters, nylons, polyolefins such as polypropylene filaments and polyethylene filaments, and biodegradable or compostable thermoplastic fibers such as polylactic acid filaments, polyhydroxyalkanoate filaments and polycaprolactone filaments. The filaments may be monocomponent or multicomponent, such as bicomponent filaments.

“Pulp fibers” as used herein means fibers that have been derived from vegetative sources, such as plants and/or trees. In one example of the present invention, “pulp fiber” refers to papermaking fibers. Papermaking fibers useful in the present invention include cellulosic pulp fibers commonly known as wood pulp fibers. Applicable wood pulps include chemical pulps, such as Kraft, sulfite, and sulfate pulps, as well as mechanical pulps including, for example, groundwood, thermomechanical pulp and chemically modified thermomechanical pulp. Chemical pulps, however, may be preferred since they impart a superior tactile sense of softness to tissue sheets made therefrom. Pulps derived from both deciduous trees (hereinafter, also referred to as “hardwood”) and coniferous trees (hereinafter, also referred to as “softwood”) may be utilized. The hardwood and softwood pulp fibers can be blended, or alternatively, can be deposited in layers to provide a stratified web. U.S. Pat. No. 4,300,981 and U.S. Pat. No. 3,994,771 are incorporated herein by reference for the purpose of disclosing layering of hardwood and softwood pulp fibers. Also applicable to the present invention are pulp fibers derived from recycled paper, which may contain any or all of the above categories as well as other non-fibrous materials such as fillers and adhesives used to facilitate the original papermaking.

In addition to the various wood pulp fibers, other pulp fibers such as cotton linters, trichomes, seed hairs, rice straw, wheat straw, bamboo, and bagasse can be used in this invention.

“Distinct from” and/or different from” as used herein means two things that exhibit different properties and/or levels of materials, for example different by 0.5 and/or 1 and/or 2 and/or 3 and/or 5 and/or 10 units and/or different by 1% and/or 3% and/or 5% and/or 10% and/or 20%, different materials, and/or different fibrous element, for example filament, diameters.

“Textured pattern” as used herein means a pattern, for example a surface pattern, such as a three-dimensional (3D) surface pattern present on a surface of the fibrous structure and/or on a surface of a component making up the fibrous structure.

“Fibrous Structure Basis Weight” as used herein is the weight per unit area of a sample reported in lbs/3000 ft² or g/m² and is measured according to the Fibrous Structure Basis Weight Test Method described herein.

“Ply” as used herein means an individual, integral fibrous structure.

“Plies” as used herein means two or more individual, integral fibrous structures disposed in a substantially contiguous, face-to-face relationship with one another, forming a multi-ply sanitary tissue product. It is also contemplated that an individual, integral fibrous structure can effectively form a multi-ply sanitary tissue product, for example, by being folded on itself.

“Machine Direction” or “MD” as used herein means the direction parallel to the flow of the fibrous structure through the fibrous structure making machine and/or manufacturing equipment.

“Cross Machine Direction” or “CD” as used herein means the direction parallel to the width of the fibrous structure through the fibrous structure making machine and/or manufacturing equipment and perpendicular to the machine direction.

"Common Intensive Property" as used herein means an intensive property possessed by more than one region within a fibrous structure. Such intensive properties of the fibrous structure include, without limitation, density, basis weight, thickness, and combinations thereof. For example, if density is a common intensive property of two or more different regions, a value of the density in one region can differ from a value of the density in one or more other regions. Regions (such as, for example, a first region and a second region and/or a continuous network region and at least one of a plurality of discrete zones) are identifiable areas visually discernible and/or visually distinguishable from one another by distinct intensive properties.

"X," "Y," and "Z" designate a conventional system of Cartesian coordinates, wherein mutually perpendicular coordinates "X" and "Y" define a reference X-Y plane, and "Z" defines an orthogonal to the X-Y plane. "Z-direction" designates any direction perpendicular to the X-Y plane. Analogously, the term "Z-dimension" means a dimension, distance, or parameter measured parallel to the Z-direction. When an element, such as, for example, a molding member curves or otherwise deplanes, the X-Y plane follows the configuration of the element.

"Substantially continuous" or “continuous” region refers to an area within which one can connect any two points by an uninterrupted line running entirely within that area throughout the line's length. That is, the substantially continuous region has a substantial "continuity" in all directions parallel to the first plane and is terminated only at edges of that region. The term "substantially," in conjunction with continuous, is intended to indicate that while an absolute continuity is preferred, minor deviations from the absolute continuity may be tolerable as long as those deviations do not appreciably affect the performance of the fibrous structure (or a molding member) as designed and intended.

"Substantially semi-continuous" or “semi-continuous” region refers an area which has "continuity" in all, but at least one, directions parallel to the first plane, and in which area one cannot connect any two points by an uninterrupted line running entirely within that area throughout the line's length. The semi-continuous framework may have continuity only in one direction parallel to the first plane. By analogy with the continuous region, described above, while an absolute continuity in all, but at least one, directions is preferred, minor deviations from such a continuity may be tolerable as long as those deviations do not appreciably affect the performance of the fibrous structure.

"Discontinuous" or "discrete" regions or zones refer to discrete, and separated from one another areas or zones that are discontinuous in all directions parallel to the first plane.

"Molding member" is a structural element that can be used as a support for the mixture of filaments and solid additives that can be deposited thereon during a process of making a fibrous structure, and as a forming unit to form (or "mold") a desired microscopical geometry of a fibrous structure. The molding member may comprise any element that has the ability to impart a three-dimensional pattern to the fibrous structure being produced thereon, and includes, without limitation, a stationary plate, a belt, a cylinder/roll, a woven fabric, and a band.

"Meltblowing" is a process for producing filaments directly from polymers or resins using high-velocity air or another appropriate force to attenuate the filaments before collecting the filaments on a collection device, such as a belt, for example a patterned belt or molding member. In a meltblowing process the attenuation force is applied in the form of high speed air as the material (polymer) exits a die or spinnerette.

"Spunbonding" is a process for producing filaments directly from polymers by allowing the polymer to exit a die or spinnerette and drop a predetermined distance under the forces of flow and gravity and then applying a force via high velocity air or another appropriate source to draw and/or attenuate the polymer into a filament.

"Stack" as used herein, refers to a neat pile of fibrous structures and/or wipes. Based upon the assumption that there are at least three wipes in a stack, each wipe, except for the topmost and bottommost wipes in the stack, will be directly in face to face contact with the wipe directly above and below itself in the stack. Moreover, when viewed from above, the wipes will be layered on top
5 of each other, or superimposed, such that only the topmost wipe of the stack will be visible. The height of the stack is measured from the bottom of the bottommost wipe in the stack to the top of the topmost wipe in the stack and is provided in units of millimeters (mm).

"Liquid composition" and "lotion" are used interchangeably herein and refer to any liquid, including, but not limited to a pure liquid such as water, an aqueous solution, a colloid, an emulsion,
10 a suspension, a solution and mixtures thereof. The term "aqueous solution" as used herein, refers to a solution that is at least about 20% and/or at least about 40% and/or at least about 50% water by weight, and is no more than 99.9% and/or no more than about 99% and/or no more than about 98% and/or no more than about 97% and/or no more than about 95% and/or no more than about 90% water by weight.

15 In one example, the liquid composition comprises water or another liquid solvent. Generally the liquid composition is of sufficiently low viscosity to impregnate the entire structure of the fibrous structure. In another example, the liquid composition may be primarily present at the

fibrous structure surface and to a lesser extent in the inner structure of the fibrous structure. In a further example, the liquid composition is releasably carried by the fibrous structure, that is the liquid composition is carried on or in the fibrous structure and is readily releasable from the fibrous structure by applying some force to the fibrous structure, for example by wiping a surface with the
5 fibrous structure.

The liquid compositions used in the present invention are primarily although not limited to, oil in water emulsions. In one example, the liquid composition of the present invention comprises at least 80% and/or at least 85% and/or at least 90% and/or at least 95% by weight water.

When present on or in the fibrous structure, the liquid composition may be present at a level
10 of from about 10% to about 1000% of the basis weight of the fibrous structure and/or from about 100% to about 700% of the basis weight of the fibrous structure and/or from about 200% to about 500% and/or from about 200% to about 400% of the basis weight of the fibrous structure.

The liquid composition may comprise an acid. Non-limiting examples of acids that can be used in the liquid composition of the present invention are adipic acid, tartaric acid, citric acid,
15 maleic acid, malic acid, succinic acid, glycolic acid, glutaric acid, malonic acid, salicylic acid, gluconic acid, polymeric acids, phosphoric acid, carbonic acid, fumaric acid and phthalic acid and mixtures thereof. Suitable polymeric acids can include homopolymers, copolymers and terpolymers, and may contain at least 30 mole % carboxylic acid groups. Specific examples of suitable polymeric acids useful herein include straight-chain poly(acrylic) acid and its copolymers,
20 both ionic and nonionic, (e.g., maleic-acrylic, sulfonic-acrylic, and styrene-acrylic copolymers), those cross-linked polyacrylic acids having a molecular weight of less than about 250,000, preferably less than about 100,000 poly (α -hydroxy) acids, poly (methacrylic) acid, and naturally occurring polymeric acids such as carageenic acid, carboxy methyl cellulose, and alginic acid. In one example, the liquid composition comprises citric acid and/or citric acid derivatives.

25 The liquid composition may also contain salts of the acid or acids used to lower the pH, or another weak base to impart buffering properties to the fibrous structure. The buffering response is due to the equilibrium which is set up between the free acid and its salt. This allows the fibrous structure to maintain its overall pH despite encountering a relatively high amount of bodily waste as would be found post urination or defecation in a baby or adult. In one embodiment the acid salt
30 would be sodium citrate. The amount of sodium citrate present in the lotion would be between 0.01 and 2.0%, alternatively 0.1 and 1.25%, or alternatively 0.2 and 0.7% of the lotion.

In one example, the liquid composition does not contain any preservative compounds. In another example, the liquid composition does contain preservative compounds.

In addition to the above ingredients, the liquid composition may comprise additional ingredients. Non-limiting examples of additional ingredients that may be present in the liquid composition of the present invention include: skin conditioning agents (emollients, humectants) including, waxes such as petrolatum, cholesterol and cholesterol derivatives, di and tri-glycerides including sunflower oil and sesame oil, silicone oils such as dimethicone copolyol, caprylyl glycol and acetoglycerides such as lanolin and its derivatives, emulsifiers; stabilizers; surfactants including anionic, amphoteric, cationic and non ionic surfactants, colourants, chelating agents including EDTA, sun screen agents, solubilizing agents, perfumes, opacifying agents, vitamins, viscosity modifiers; such as xanthan gum, astringents and external analgesics.

In one example, the liquid composition comprises a surfactant; an acidifying agent; an amide of formula I:



wherein R^1 is selected from the group consisting of linear or branched, substituted or unsubstituted C_6-C_{12} , each of R^2 and R^3 is independently selected from H, OH, a halogen, or C_1-C_6 linear or branched, substituted or unsubstituted hydrocarbyl groups; and water; wherein said composition has a pH from about 1.0 to about 6.0 and/or from about 2.5 to about 5.0. The liquid composition may comprise an antibacterial agent, for example from about 0.01% to about 30% of an antimicrobial active, such as an antimicrobial active selected from ionic silver, an active oxygen source, or mixtures thereof. In one example, the antimicrobial active is an active oxygen source, wherein the active oxygen source is hydrogen peroxide, and the active oxygen source is present at a level of from about 0.05% to about 8% by weight of the liquid composition. In one example, the antimicrobial active is an active oxygen source, wherein the active oxygen source is hydrogen peroxide and further comprises from 1 to about 50 ppm of C_{6-10} fatty peracid.

In one example the liquid composition comprises from about 0.01% to about 60% by weight of said surfactant, from about 0.01% to about 40% and/or from about 0.03% to about 25% by weight of said acidifying agent, from about 0.01% to about 40% and/or from about 0.03% to about 25% by weight of said amide of formula I, and from about 15% to about 99.95% by weight of said water.

The surfactant within the liquid composition may be a C_6-C_{12} surfactant. In one example, the surfactant may be selected from the group consisting of C_8 glyceryl ether sulfonate, C_2-C_8 linear alkyl benzene sulfonate, C_6-C_{12} alkyl sulfate, C_8-C_{12} methyl ester sulfonate, C_8-C_{12} fatty acid sulfonate, C_6-C_{12} alkylethoxy carboxylate, C_6-C_{12} alkylethoxy sulfate, C_{8-10} dimethyl amine oxide, C_8 pyrrolidone, C_8 dimethyl betaine, C_{8-10} alkyl polyglycoside, C_{8-12} N,N-dimethyl-3-ammonio-1-propanesulfonate, and mixtures thereof.

In one example, the acidifying agent is selected from the group consisting of formic acid, acetic acid, benzoic acid, malonic acid, citric acid, maleic acid, fumaric acid, hypochlorous acid, succinic acid, gluconic acid, glutaric acid, lactic acid, 2-ethyl-1-hexanoic acid, cinnamic acid, heptanoic acid, octanoic acid, nonanoic acid, peracetic acid, peroctanoic acid, undecylenic acid, and mixtures thereof.

In one example, the amide of formula I is selected from the group consisting of N,N-dimethyl octanamide, N,N-dimethyl decanamide, N,N-dimethyl 9-decanamide, N,N-dimethyl 7-octenamide, octanohydroxamic acid, and mixtures thereof.

In one example, when present, the surfactant and the antimicrobial active, for example hydrogen peroxide, are present in the liquid composition at a weight ratio of surfactant to antimicrobial active of from about 0.1:1 to about 10:1.

In one example, when present, the acidifying agent and the antimicrobial active, for example hydrogen peroxide, of from about 0.2:1 to about 5:1.

In one example, when present, the amide of formula I, for example the amide of formula I wherein R¹ is selected from the group consisting of linear or branched, substituted or unsubstituted C₆-C₁₀ hydrocarbyl groups, and the antimicrobial active, for example hydrogen peroxide, are present in the liquid composition at a weight ratio of antimicrobial active to the amide of formula I of from about 0.2:1 to about 5:1.

In one example, the liquid composition may further comprise a solvent, for example a solvent selected from the group consisting of ethanol, isopropanol, C₁-C₈ monoethylene glycol ether, C₁-C₈ diethylene glycol ether, C₁-C₈ triethylene glycol ether, C₁-C₆ monopropylene glycol ether, C₁-C₆ dipropylene glycol ether, C₁-C₆ tripropylene glycol ether, C₁-C₆ esters of formic acid, C₁-C₆ esters of acetic acid, C₁-C₆ esters of benzoic acid, C₁-C₆ esters of lactic acid, C₁-C₆ esters of 3-hydroxybutyric acid, C₁-C₆ amines, C₁-C₆ alkanol amines, and mixtures thereof.

The liquid composition may exhibit a critical micelle concentration from about 100 ppm to about 2,500 ppm.

"Pre-moistened" and "wet" are used interchangeably herein and refer to fibrous structures and/or wipes which are moistened with a liquid composition prior to packaging in a generally moisture impervious container or wrapper. Such pre-moistened wipes, which can also be referred to as "wet wipes" and "towelettes", may be suitable for use in cleaning babies, as well as older children and adults.

"Saturation loading" and "lotion loading" are used interchangeably herein and refer to the amount of liquid composition applied to the fibrous structure or wipe. In general, the amount of liquid composition applied may be chosen in order to provide maximum benefits to the end product

comprised by the wipe. Saturation loading is typically expressed as grams of liquid composition per gram of dry wipe.

Saturation loading, often expressed as percent saturation, is defined as the percentage of the dry fibrous structure or wipe's mass (void of any liquid composition) that a liquid composition present on/in the fibrous structure or wipe represents. For example, a saturation loading of 1.0 (equivalently, 100% saturation) indicates that the mass of liquid composition present on/in the fibrous structure or wipe is equal to the mass of dry fibrous structure or wipe (void of any liquid composition).

The following equation is used to calculate saturation load of a fibrous structure or wipe:

$$10 \quad \text{Saturation Loading} = \left[\frac{\text{wet wipe mass}}{(\text{wipe size}) * (\text{basis weight})} \right] - 1$$

"Saturation gradient index" (SGI) is a measure of how well the wipes at the top of a stack retain moisture. The SGI of a stack of wipes is measured as described infra and is calculated as the ratio of the average lotion load of the bottommost wipes in the stack versus the topmost wipes in the stack. The ideal stack of wipes will have an SGI of about 1.0; that is, the topmost wipes will be equally as moist as the bottommost wipes. In the aforementioned embodiments, the stacks have a SGI from about 1.0 to about 1.5.

The saturation gradient index for a fibrous structure or wipe stack is calculated as the ratio of the saturation loading of a set number of fibrous structures or wipes from the bottom of a stack to that of the same number of fibrous structures or wipes from the top of the stack. For example, for an approximately 80 count wipe stack, the saturation gradient index is this ratio using 10 wipes from bottom and top; for an approximately 30 count wipe stack, 5 wipes from bottom and top are used; and for less than 30, only the top and bottom single wipes are used in the saturation gradient index calculation. The following equation illustrates the example of an 80 count stack saturation gradient index calculation:

$$25 \quad \text{Saturation Gradient Index} = \frac{\text{average lotion load of bottom 10 wipes in stack}}{\text{average lotion load of top 10 wipes in stack}}$$

A saturation profile, or wetness gradient, exists in the stack when the saturation gradient index is greater than 1.0. In cases where the saturation gradient index is significantly greater than 1.0, e.g. over about 1.5, lotion is draining from the top of the stack and settling in the bottom of the container, such that there may be a noticeable difference in the wetness of the topmost fibrous structures or wipes in the stack compared to that of the fibrous structures or wipes nearest the bottom of the stack. For example, a perfect tub of wipes would have a saturation gradient index of 1.0; the bottommost wipes and topmost wipes would maintain equivalent saturation loading during

storage. Additional liquid composition would not be needed to supersaturate the wipes in an effort to keep all of the wipes moist, which typically results in the bottommost wipes being soggy.

“Percent moisture” or “% moisture” or “moisture level” as used herein means $100 \times$ (the ratio of the mass of water contained in a fibrous structure to the mass of the fibrous structure). The product of the above equation is reported as a %.

“Surface tension” as used herein, refers to the force at the interface between a liquid composition and air. Surface tension is typically expressed in dynes per centimeter (dynes/cm).

“Surfactant” as used herein, refers to materials which preferably orient toward an interface. Surfactants include the various surfactants known in the art, including: nonionic surfactants; anionic surfactants; cationic surfactants; amphoteric surfactants, zwitterionic surfactants; and mixtures thereof.

“Visually Discernible” as used herein, refers to being capable of being seen by the naked eye when viewed at a distance of 12 inches (in), or 30.48 centimeters (cm), under the unimpeded light of an ordinary incandescent 60 watt light bulb that is inserted in a fixture such as a table lamp. It follows that “visually discernible” as used herein refers to those features of fibrous structures, whether or not they are pre-moistened, that are readily visually discernible when the wipe is subjected to normal use, such as the cleaning of a child's skin.

As used herein, the articles “a” and “an” when used herein, for example, “an anionic surfactant” or “a fiber” is understood to mean one or more of the material that is claimed or described.

All percentages and ratios are calculated by weight unless otherwise indicated. All percentages and ratios are calculated based on the total composition unless otherwise indicated.

Unless otherwise noted, all component or composition levels are in reference to the active level of that component or composition, and are exclusive of impurities, for example, residual solvents or by-products, which may be present in commercially available sources.

Cleaning Pad

As shown in Figs. 2-5, the cleaning pads 1 of the present invention exhibit a basis weight of at least 100 gsm, wherein the cleaning pad 1 comprises a core component 24, which in effect is two or more core components 24 (the single core component has been split into two or more core components) comprising two or more fibrous structure plies 10 comprising pulp fibers and one or more scrim components 26, wherein each of the fibrous structure plies exhibits a basis weight of less than 250 gsm and/or less than 225 gsm and/or less than 200 gsm and/or less than 175 gsm and/or less than 150 gsm and/or less than 130 gsm and/or less than 120 gsm and/or less

than 110 gsm and at least one of the fibrous structure plies exhibits a basis weight of greater than 70 gsm to less than 250 gsm.

In one example, the at least one fibrous structure ply 10 exhibits a basis weight of greater than 75 gsm to less than 250 gsm and/or at least 80 gsm to less than 250 gsm and/or at least 80 gsm to less than 240 gsm and/or at least 80 gsm to less than 200 gsm and/or at least 80 gsm to less than 180 gsm and/or at least 80 gsm to less than 160 gsm.

In one example, at least two of the fibrous structure plies 10 exhibit basis weights of greater than 70 gsm to less than 250 gsm and/or greater than 75 gsm to less than 250 gsm and/or at least 80 gsm to less than 250 gsm and/or at least 80 gsm to less than 240 gsm and/or at least 80 gsm to less than 200 gsm and/or at least 80 gsm to less than 180 gsm and/or at least 80 gsm to less than 160 gsm.

In one example, at least three of the fibrous structure plies 10 exhibit basis weights of greater than 70 gsm to less than 250 gsm and/or greater than 75 gsm to less than 250 gsm and/or at least 80 gsm to less than 250 gsm and/or at least 80 gsm to less than 240 gsm and/or at least 80 gsm to less than 200 gsm and/or at least 80 gsm to less than 180 gsm and/or at least 80 gsm to less than 160 gsm.

As shown in Figs. 2 and 4, the two or more and/or three or more fibrous structure plies 10 are plied directly together, such as by chemical (for example glue) and/or mechanical association.

As shown in Figs. 3 and 5, the two or more and/or three or more fibrous structure plies 10 have an interior scrim component 26 positioned between the two or more and/or three or more fibrous structure plies.

As shown in Figs. 6A and 6B, the cleaning pad 1 of the present invention may be associated with an implement 15, for example a cleaning pad holder 17, to which a handle 19
5 may be movably attached, during use of the cleaning pad 1 for cleaning a surface 21 to be cleaned, such as a floor surface.

As shown in Figs. 6A and 6B, the cleaning pad 1 of the present invention comprises a one or more attachment portions 13, for example two attachment portions, that attaches the cleaning pad 1 to an implement 15, for example a cleaning pad holder 17, to which a handle 19 may be
10 movably attached, during use of the cleaning pad 1 for cleaning a surface 21 to be cleaned, such as a floor surface. In addition to at least one attachment portion 13, the cleaning pad 1 may further comprise a cleaning portion 23. The cleaning portion 23 may be in fluid communication with at least one of the attachment portions 13 such that a liquid composition from the attachment
15 portion 13 may replenish the cleaning portion 23 when any cleaning portion's liquid exits the cleaning pad 1 during cleaning of a surface 21.

In addition to the cleaning portion 23 and at least one attachment portion 13, the cleaning pad 1 may further comprise one or more edge portions 25 positioned between the cleaning portion 23 and at least one attachment portion 13.

As shown in Figs. 6A and 6B, the arrow A represents the direction at which the cleaning pad 1 as attached to the implement 15 moves across a surface 21, such as a floor surface, during use. When the cleaning pad 1 is moving across the surface 21, the cleaning pad 1 has a leading edge 27 and a trailing edge 29. If the cleaning pad 1 moves in the opposite direction of the arrow A, then the leading edge and trailing edge would be opposite.

The cleaning pad 1 of the present invention may exhibit a basis weight of greater than 100
10 gsm and/or greater than 120 gsm and/or greater than 140 gsm and/or greater than 160 gsm.

The cleaning pad 1 may exhibit the same or different sides or in other words may have the same or different properties and/or surfaces on both of its sides.

Fibrous Structures

In one example, the fibrous structures of the present invention used in the pre-moistened
15 cleaning pads of the present invention comprise a plurality of filaments and a plurality of solid additives. The filaments and the solid additives may be commingled together. In one example, the fibrous structure is a coform fibrous structure comprising filaments and solid additives. The filaments may be present in the fibrous structures of the present invention at a level of less than 90% and/or less than 80% and/or less than 65% and/or less than 50% and/or greater than 5% and/or
20 greater than 10% and/or greater than 20% and/or from about 10% to about 50% and/or from about 25% to about 45% by weight of the fibrous structure on a dry basis.

The solid additives may be present in the fibrous structures of the present invention at a level of greater than 10% and/or greater than 25% and/or greater than 50% and/or less than 100% and/or less than 95% and/or less than 90% and/or less than 85% and/or from about 30% to about
25 95% and/or from about 50% to about 85% by weight of the fibrous structure on a dry basis.

The filaments and solid additives may be present in the fibrous structures of the present invention at a weight ratio of filaments to solid additive of greater than 10:90 and/or greater than 20:80 and/or less than 90:10 and/or less than 80:20 and/or from about 25:75 to about 50:50 and/or from about 30:70 to about 45:55. In one example, the filaments and solid additives are present in
30 the fibrous structures of the present invention at a weight ratio of filaments to solid additives of greater than 0 but less than 1.

In one example, the fibrous structures of the present invention exhibit a basis weight of from about 10 gsm to about 1000 gsm and/or from about 10 gsm to about 500 gsm and/or from about 15 gsm to about 400 gsm and/or from about 15 gsm to about 300 gsm as measured according

to the Fibrous Structure Basis Weight Test Method described herein. In another example, the fibrous structures of the present invention exhibit a basis weight of from about 10 gsm to about 200 gsm and/or from about 20 gsm to about 150 gsm and/or from about 25 gsm to about 125 gsm and/or from about 30 gsm to about 100 gsm and/or from about 30 gsm to about 80 gsm as measured according to the Fibrous Structure Basis Weight Test Method described herein. In still another example, the fibrous structures of the present invention exhibit a basis weight of from about 80 gsm to about 1000 gsm and/or from about 125 gsm to about 800 gsm and/or from about 150 gsm to about 500 gsm and/or from about 150 gsm to about 300 gsm as measured according to the Fibrous Structure Basis Weight Test Method described herein.

In one example, as shown in Figs. 4A and 4B, the fibrous structure 10 of the present invention may comprise a core component 24. A “core component” as used herein means a fibrous structure 10 comprising a plurality of filaments and optionally a plurality of solid additives, wherein the fibrous structure 10 comprises at least one interior surface not exposed to the external environment, such as not exposed to a surface to be cleaned. In one example, the core component
5 is a coform fibrous structure comprising a plurality of filaments and a plurality of solid additives, for example pulp fibers. In one example, the core component 24 is the component that exhibits the greatest basis weight with the fibrous structure 10 of the present invention. In one example, the total core components present in the fibrous structures of the present invention exhibit a basis
10 weight that is greater than 50% and/or greater than 55% and/or greater than 60% and/or greater than 65% and/or greater than 70% and/or less than 100% and/or less than 95% and/or less than 90% of the total basis weight of the fibrous structure of the present invention as measured according to the Fibrous Structure Basis Weight Test Method described herein. In another example, the core component exhibits a basis weight of greater than 12 gsm and/or greater than 14 gsm and/or greater
15 than 16 gsm and/or greater than 18 gsm and/or greater than 20 gsm and/or greater than 25 gsm as measured according to the Fibrous Structure Basis Weight Test Method described herein.

“Consolidated region” as used herein means a region within a fibrous structure where the filaments and optionally the solid additives have been compressed, compacted, and/or packed together with pressure and optionally heat (greater than 150°F) to strengthen the region compared
20 to the same region in its unconsolidated state or a separate region which did not see the compression or compacting pressure. In one example, a region is consolidated by forming unconsolidated regions within a fibrous structure on a patterned molding member and passing the unconsolidated regions within the fibrous structure while on the patterned molding member through a pressure nip, such as a heated metal anvil roll (about 275°F) and a rubber anvil roll with pressure to compress
25 the unconsolidated regions into one or more consolidated regions. In one example, the filaments

present in the consolidated region, for example on the side of the fibrous structure that is contacted by the heated roll comprises fused filaments that create a skin on the surface of the fibrous structure, which may be visible via SEM images.

The fibrous structure 10 of the present invention may, in addition to a core component 24, further comprise a scrim component 26. “Scrim component” as used herein means a fibrous structure comprising a plurality of filaments that form at least one exterior surface, for example the scrim component 26 contacts a surface to be cleaned, of the fibrous structure 10 and is different from the core component 24. In one example, the total scrim components present in the fibrous structures of the present invention exhibit a basis weight that is less than 25% and/or less than 20% and/or less than 15% and/or less than 10% and/or less than 7% and/or less than 5% and/or greater than 0% and/or greater than 1% of the total basis weight of the fibrous structure of the present invention as measured according to the Fibrous Structure Basis Weight Test Method described herein. In another example, the scrim component exhibits a basis weight of 10 gsm or less and/or less than 10 gsm and/or less than 8 gsm and/or less than 6 gsm and/or greater than 5 gsm and/or less than 4 gsm and/or greater than 0 gsm and/or greater than 1 gsm as measured according to the Fibrous Structure Basis Weight Test Method described herein.

A scrubby component (not shown) may also be included in the fibrous structure of the present invention. “Scrubby component” as used herein means that part of the fibrous structure of the present invention that imparts the scrubby quality to the fibrous structure. The scrubby component is distinct and different from the core and scrim components even though the scrubby component may be present in and/or on the core and scrim components. The scrubby component may be a feature, such as a pattern, for example a surface pattern, or texture that causes the fibrous structure to exhibit a scrubby property during use by a consumer. In another example, the scrubby component may be a material, for example a coarse filament (exhibits a greater average diameter than the majority of filaments within the core and/or scrim components). In one example, the scrubby component is a fibrous structure comprising a plurality of filaments. In one example, the total scrubby components present in the fibrous structures of the present invention exhibit a basis weight that is less than 25% and/or less than 20% and/or less than 15% and/or less than 10% and/or less than 7% and/or less than 5% and/or greater than 0% and/or greater than 1% of the total basis weight of the fibrous structure of the present invention as measured according to the Fibrous Structure Basis Weight Test Method described herein. In another example, the scrubby component exhibits a basis weight of 10 gsm or less and/or less than 10 gsm and/or less than 8 gsm and/or less than 6 gsm and/or greater than 5 gsm and/or less than 4 gsm and/or greater than 0 gsm and/or

greater than 1 gsm as measured according to the Fibrous Structure Basis Weight Test Method described herein.

In one example, at least one of the core components of the fibrous structure comprises a plurality of solid additives, for example pulp fibers, such as comprise wood pulp fibers and/or non-wood pulp fibers.

In one example, at least one of the core components of the fibrous structure comprises a plurality of core filaments. In another example, at least one of the core components comprises a plurality of solid additives and a plurality of the core filaments. In one example, the solid additives and the core filaments are present in a layered orientation within the core component. In one example, the core filaments are present as a layer between two solid additive layers. In another example, the solid additives and the core filaments are present in a coform layer. At least one of the core filaments comprises a polymer, for example a thermoplastic polymer, such as a polyolefin. The polyolefin may be selected from the group consisting of: polypropylene, polyethylene, and mixtures thereof. In another example, the thermoplastic polymer of the core filament may comprise a polyester.

In one example, at least one of the core components comprises one or more scrubby components, for example a scrubby element, such as a scrubby filament. In one example, the scrubby filaments comprise a polymer, for example a thermoplastic polymer and/or hydroxyl polymer as described above with reference to the core components.

In one example, the scrubby filaments exhibit a diameter of less than 3 mm and/or less than 2 mm and/or less than 1 mm and/or less than 750 μm and/or less than 500 μm and/or less than 250 μm and/or greater than 50 μm and/or greater than 75 μm and/or greater than 100 μm as measured according to the Diameter Test Method described herein.

In one example, at least one of the scrim components is adjacent to at least one of the core components within the fibrous structure. In another example, at least one of the core components is positioned between two scrim components within the fibrous structure.

In one example, at least one of the scrim components of the fibrous structure of the present invention comprises a plurality of scrim filaments, for example scrim filaments, wherein the scrim filaments comprise a polymer, for example a thermoplastic and/or hydroxyl polymer as described above with reference to the core components.

In one example, at least one of the scrim filaments exhibits a diameter of less than 50 and/or less than 25 and/or less than 10 and/or at least 1 and/or greater than 1 and/or greater than 3 μm as measured according to the Diameter Test Method described herein.

In one example, at least one of the scrim components of the fibrous structures of the present invention comprises one or more scrubby components, for example a scrubby element, such as a scrubby filament. In one example, the scrubby filaments comprise a polymer, for example a thermoplastic polymer and/or hydroxyl polymer as described above with reference to the core components.

In one example, the scrubby filaments exhibit a diameter of less than 250 and/or less than 200 and/or less than 150 and/or less than 120 and/or less than 100 and/or 75 and/or less than 50 and/or less than 40 and/or less than 30 and/or less than 25 and/or greater than 0.6 and/or greater than 1 and/or greater than 3 and/or greater than 5 and/or greater than 10 μm as measured according to the Diameter Test Method described herein.

In another example, the scrubby element of the scrim component may comprise a pattern, for example a surface pattern, such as a textured pattern, present on a surface of the scrim component. The pattern may comprise a non-random, repeating pattern. The pattern may comprise a pattern molding member-imparted pattern.

The diameter of the core filaments is less than 250 and/or less than 200 and/or less than 150 and/or less than 100 and/or less than 50 and/or less than 30 and/or less than 25 and/or less than 10 and/or greater than 1 and/or greater than 3 μm as measured according to the Diameter Test Method described herein.

5 In one example, the fibrous structures of the present invention may comprise any suitable amount of filaments and any suitable amount of solid additives. For example, the fibrous structures may comprise from about 10% to about 70% and/or from about 20% to about 60% and/or from about 30% to about 50% by dry weight of the fibrous structure of filaments and from about 90%
10 to about 30% and/or from about 80% to about 40% and/or from about 70% to about 50% by dry weight of the fibrous structure of solid additives, such as wood pulp fibers.

In one example, the filaments and solid additives of the present invention may be present in fibrous structures according to the present invention at weight ratios of filaments to solid additives of from at least about 1:1 and/or at least about 1:1.5 and/or at least about 1:2 and/or at least about 1:2.5 and/or at least about 1:3 and/or at least about 1:4 and/or at least about 1:5 and/or
15 at least about 1:7 and/or at least about 1:10.

In one example, the solid additives, for example wood pulp fibers, may be selected from the group consisting of softwood kraft pulp fibers, hardwood pulp fibers, and mixtures thereof. Non-limiting examples of hardwood pulp fibers include fibers derived from a fiber source selected from the group consisting of: Acacia, Eucalyptus, Maple, Oak, Aspen, Birch, Cottonwood, Alder,
20 Ash, Cherry, Elm, Hickory, Poplar, Gum, Walnut, Locust, Sycamore, Beech, Catalpa, Sassafras,

Gmelina, Albizia, Anthocephalus, and Magnolia. Non-limiting examples of softwood pulp fibers include fibers derived from a fiber source selected from the group consisting of: Pine, Spruce, Fir, Tamarack, Hemlock, Cypress, and Cedar. In one example, the hardwood pulp fibers comprise tropical hardwood pulp fibers. Non-limiting examples of suitable tropical hardwood pulp fibers
5 include Eucalyptus pulp fibers, Acacia pulp fibers, and mixtures thereof.

In one example, the wood pulp fibers comprise softwood pulp fibers derived from the kraft process and originating from southern climates, such as Southern Softwood Kraft (SSK) pulp fibers. In another example, the wood pulp fibers comprise softwood pulp fibers derived from the kraft process and originating from northern climates, such as Northern Softwood Kraft (NSK) pulp
10 fibers.

The wood pulp fibers present in the fibrous structure may be present at a weight ratio of softwood pulp fibers to hardwood pulp fibers of from 100:0 and/or from 90:10 and/or from 86:14 and/or from 80:20 and/or from 75:25 and/or from 70:30 and/or from 60:40 and/or about 50:50 and/or to 0:100 and/or to 10:90 and/or to 14:86 and/or to 20:80 and/or to 25:75 and/or to 30:70
15 and/or to 40:60. In one example, the weight ratio of softwood pulp fibers to hardwood pulp fibers is from 86:14 to 70:30.

In one example, the fibrous structures of the present invention comprise one or more trichomes. Non-limiting examples of suitable sources for obtaining trichomes, especially trichome fibers, are plants in the *Labiatae (Lamiaceae)* family commonly referred to as the mint family. Examples of suitable species in the *Labiatae* family include *Stachys byzantina*, also known as
20 *Stachys lanata* commonly referred to as lamb's ear, woolly betony, or woundwort. The term *Stachys byzantina* as used herein also includes cultivars *Stachys byzantina* 'Primrose Heron', *Stachys byzantina* 'Helene von Stein' (sometimes referred to as *Stachys byzantina* 'Big Ears'), *Stachys byzantina* 'Cotton Boll', *Stachys byzantina* 'Variegated' (sometimes referred to as *Stachys*
25 *byzantina* 'Striped Phantom'), and *Stachys byzantina* 'Silver Carpet'.

In another example, the fibrous structure of the present invention, alone or as a ply of fibrous structure in a multi-ply fibrous structure, comprises a creped fibrous structure. The creped fibrous structure may comprise a fabric creped fibrous structure, a belt creped fibrous structure, and/or a cylinder creped, such as a cylindrical dryer creped fibrous structure. In one example, the
30 fibrous structure may comprise undulations and/or a surface comprising undulations.

In yet another example, the fibrous structure of the present invention, alone or as a ply of fibrous structure in a multi-ply fibrous structure, comprises an uncreped fibrous structure.

In still another example, the fibrous structure of the present invention, alone or as a ply of fibrous structure in a multi-ply fibrous structure, comprises a foreshortened fibrous structure.

In another example of a fibrous structure in accordance with the present invention, instead of being layers of fibrous structure, the material forming layers may be in the form of plies wherein two or more of the plies may be combined to form a multi-ply fibrous structure. The plies may be bonded together, such as by thermal bonding and/or adhesive bonding, to form the multi-ply
5 fibrous structure. After a bonding operation, especially a thermal bonding operation, it may be difficult to distinguish the plies of the fibrous structure and the fibrous structure may visually and/or physically be a similar to a layered fibrous structure in that one would have difficulty separating the once individual plies from each other.

The fibrous structures of the present invention and/or any sanitary tissue products
10 comprising such fibrous structures may be subjected to any post-processing operations such as embossing operations, printing operations, tuft-generating operations, thermal bonding operations, ultrasonic bonding operations, perforating operations, surface treatment operations such as application of lotions, silicones and/or other materials and mixtures thereof.

Non-limiting examples of suitable polypropylenes for making the filaments of the present
15 invention are commercially available from Lyondell-Basell and Exxon-Mobil.

Any hydrophobic or non-hydrophilic materials within the fibrous structure, such as polypropylene filaments, may be surface treated and/or melt treated with a hydrophilic modifier. Non-limiting examples of surface treating hydrophilic modifiers include surfactants, such as Triton X-100. Non-limiting examples of melt treating hydrophilic modifiers that are added to the melt,
20 such as the polypropylene melt, prior to spinning filaments, include hydrophilic modifying melt additives such as VW351 and/or S-1416 commercially available from Polyvel, Inc. and Irgasurf commercially available from Ciba. The hydrophilic modifier may be associated with the hydrophobic or non-hydrophilic material at any suitable level known in the art. In one example, the hydrophilic modifier is associated with the hydrophobic or non-hydrophilic material at a level
25 of less than about 20% and/or less than about 15% and/or less than about 10% and/or less than about 5% and/or less than about 3% to about 0% by dry weight of the hydrophobic or non-hydrophilic material.

The fibrous structures of the present invention may include optional additives, each, when present, at individual levels of from about 0% and/or from about 0.01% and/or from about 0.1%
30 and/or from about 1% and/or from about 2% to about 95% and/or to about 80% and/or to about 50% and/or to about 30% and/or to about 20% by dry weight of the fibrous structure. Non-limiting examples of optional additives include permanent wet strength agents, temporary wet strength agents, dry strength agents such as carboxymethylcellulose and/or starch, softening agents, lint reducing agents, opacity increasing agents, wetting agents, odor absorbing agents, perfumes,

temperature indicating agents, color agents, dyes, osmotic materials, microbial growth detection agents, antibacterial agents, liquid compositions, surfactants, and mixtures thereof.

The fibrous structures of the present invention may be pre-moistened, such as may comprise a liquid composition, wherein the fibrous structures exhibit mileage values of at least 135
5 ft²/pre-moistened fibrous structure (floor cleaning pad) and/or at least 0.9 ft²/gsm of the dry fibrous structure (dry floor cleaning pad) and/or at least 450 ft²/ft² (at least 400 ft²/ft² for a unitary, non-laminate, for example a pre-moistened fibrous structure that doesn't have a separate floor sheet attached thereto) of pre-moistened fibrous structure (floor cleaning pad) as measured according to the Mileage Test Method described herein.

10 In one example, a pre-moistened fibrous structure of the present invention exhibits a mileage value of at least 135 and/or greater than 140 and/or greater than 150 and/or greater than 170 and/or greater than 190 and/or greater than 210 and/or greater than 230 and/or greater than 250
15 ft²/pre-moistened fibrous structure (floor cleaning pad) as measured according to the Mileage Test Method described herein. In another example, a pre-moistened fibrous structure of the present invention exhibits a mileage value of at least 165 and/or at least 190 and/or at least 220 and/or at least 260 ft²/pre-moistened fibrous structure (floor cleaning pad) as measured according to the Mileage Test Method described herein.

In another example, a pre-moistened fibrous structure of the present invention exhibits a mileage value of at least 0.9 and/or greater than 0.95 and/or greater than 1 and/or greater than 1.1
20 and/or greater than 1.2 and/or greater than 1.3 and/or greater than 1.4 ft²/gsm of the dry fibrous structure (dry floor cleaning pad) as measured according to the Mileage Test Method described herein. In another example, a pre-moistened fibrous structures of the present invention example exhibits a mileage value of at least 1.1 and/or at least 1.3 and/or at least 1.5 ft²/gsm of the dry fibrous structure as measured according to the Mileage Test Method described herein.

25 In another example, a pre-moistened fibrous structure of the present invention exhibits a mileage value of at least 450 and/or greater than 500 and/or greater than 550 and/or greater than 600 and/or greater than 650 and/or greater than 700 and/or greater than 800 and/or greater than 850
30 ft²/ft² of the pre-moistened fibrous structure (floor cleaning pad) as measured according to the Mileage Test Method described herein. In another example, a pre-moistened fibrous structure of the present invention exhibits a mileage value of at least 500 and/or at least 600 and/or at least 700 and/or at least 850 ft²/ft² of the pre-moistened fibrous structure (floor cleaning pad) as measured according to the Mileage Test Method described herein.

In one example, a pre-moistened fibrous structure of the present invention may exhibit one or more, such as a combination, of the mileage values described above.

In addition to increased mileage, the fibrous structures of the present invention exhibit increased capacity. In one example, the fibrous structures of the present invention exhibit capacity values of at least 8.5 g of liquid composition/g of dried fibrous structure (dried floor cleaning pad) as measured according to the Capacity Test Method described herein.

5 In one example, a pre-moistened fibrous structure of the present invention exhibits a capacity value of at least 8.5 and/or greater than 8.7 and/or greater than 9 and/or greater than 9.2 and/or greater than 9.5 and/or greater than 10 g of liquid composition/g of dried fibrous structure (dried floor cleaning pad) as measured according to the Capacity Test Method described herein. In another example, a pre-moistened fibrous structure of the present invention exhibits a capacity
10 value of at least 8.5 and/or at least 9 and/or at least 9.4 and/or at least 10.1 g of liquid composition/g of dried fibrous structure (dried floor cleaning pad) as measured according to the Capacity Test Method described herein.

Method For Making A Fibrous Structure

A non-limiting example of a method for making a fibrous structure according to the present
15 invention is represented in Figs. 7-11. The method 50 for making a fibrous structure 10 according to the present invention comprises the steps of: 1) as shown in Fig. 7, collecting a plurality of filaments 52 and/or a mixture of filaments 52 and solid additives 54, such as fibers, for example pulp fibers, onto a collection device 56, which in this case is a patterned molding member 54, that imparts a texture to at least one surface of the fibrous structure 10 ultimately produced by the
20 method and with the aid of a sufficient amount of vacuum applied to the collection device 56 by vacuum boxes 58. This step of collecting the filaments 52 and/or the mixture of filaments 52 and solid additives 54 on the collection device 56 may comprise subjecting the fibrous structure 10 while on the collection device 56 to a consolidation step by passing the fibrous structure 10 while still on the collection device 56 through a nip formed by two rolls 60, such as steel rolls or a rubber
25 and a steel roll, heated or unheated, flat or patterned, whereby the fibrous structure, while present on the collection device 56.

The method 50 shown in Fig. 7 comprises the steps of a) collecting a plurality of filaments 52 onto a collection device 56, for example a belt or fabric, such as a molding member 62, to form a scrim component 26. In one example, the collection device 56 such as the molding member 62
30 may be a straight run while the filaments 52 and solid additives 54 are being collected thereon, unlike as shown in Fig. 7. The collection of the plurality of filaments 52 onto the collection device 56 to form the scrim component 26 is vacuum assisted by one or more vacuum boxes 58. It has been found that providing sufficient vacuum aids in the pulling or deflection of the filaments 52 of the scrim component 26 into the molding member 62 such that contact surface protrusions (micro

protrusions) are formed in the fibrous structure 10. For example, as shown in Figs 8 and 9, a molding member 62 may comprise a reinforcing element 64, such as a woven fabric, and a resin 66 disposed on the reinforcing element 64. The resin 66 is arranged to form conduits and/or open areas, for example in the form of a pattern, that exposes the reinforcing element 64, to the filaments 52 and/or the mixture of filaments 52 and solid additives 54 during the fibrous structure making process. As shown in Fig. 9, when the filaments 52 and/or the mixture of filaments 52 and solid additives 54 are deposited onto the collection device 56; namely, the molding member 62, the filaments 52 and/or the mixture of filaments 52 and solid additives 54 are pulled into the deflection conduit or opening 67 formed by the resin 66 of the molding member 62 and ultimately into the interstices of the reinforcing element 64 to resulting in the formation of a protruding surface (macro protrusion surface) with a contact surface (micro protrusion surface) and contact surface protrusions (micro protrusions). In this example, the vacuum box 58 supplies sufficient vacuum to pull the filaments 52 of the scrim component 26 partially into and/or through the reinforcing element 64 to create the contact surface protrusions (micro protrusions). Depending upon the level of vacuum, the filaments 52 of the scrim component 26 and/or the mixture of the filaments 52 and the solid additives 54 may conform to the collection device 56, for example a molding member 62. The filaments 52 of the present invention may be sourced from a filament source, such as a die 68, for example a meltblow die.

In one example, once the scrim component 26 is formed on the collection device 56, the next step is to mix, such as commingle, a plurality of solid additives 54, such as fibers, for example pulp fibers, such as wood pulp fibers, with a plurality of filaments 52, such as in a coform box 70, and collecting the mixture on the scrim component 26 carried on the collection device 56 to form a core component 24. The collection of the mixture may be vacuum assisted by a vacuum box 58. The vacuum applied via the vacuum box 58 to the mixture may be sufficient to achieve a solid additive concentration difference (difference in average weight % of solid additives) between two or more regions of the fibrous structure 10. It is believed that the rearrangement of the fibers can take one of two modes dependent on a number of factors such as, for example, filament/fiber length. The filaments may bridge the deflection conduits spanning from one ridge to another ridges and may be merely bent into the space defined by the deflection conduit. The solid additives, for example fibers, such as pulp fibers, for example wood pulp fibers, can actually be transported from the region of the ridges of the collection device 56 and into the deflection conduits of the collection device 56.

Optionally, an additional scrim component 26 comprising filaments 52 from a filament source, such as a die 68, for example a meltblow die, may be added to the core component 24 to sandwich the core component 24 between two scrim components 26.

While not wishing to be bound by theory, the vacuum applied via the vacuum boxes 58 to the core and scrim layers may be selected to achieve common intensive properties such as the basis weight, density, or thickness. It is believed that the arrangement of the filaments and solid additives as they accumulate on the collection device may take on different modes dependent on a number of factors such as, for example, filament/fiber length, size of the openings or deflection conduits in the patterned molding member, depth of the deflection conduits in the patterned molding member, filament mobility, fiber mobility, filament temperature hence its drawability, or combinations thereof. The filaments may bridge the deflection conduits spanning from one ridge to other ridges and may be merely bent into the space defined by the deflection conduit while maintaining a position on top of a ridge. The solid additives, for example fibers, such as pulp fibers, for example wood pulp fibers, may be transported or dragged by the vacuum air from the region above the ridges of the collection device 56, for example the molding member 62 and into the deflection conduits or openings 67 of the collection device 56, for example the molding member 62, while the continuous filaments will remain on the ridge or top of the deflection conduit as they lack mobility for example because of their length. Generally, the filaments and solid additives will tend to migrate with the path of the air flow as is established by the vacuum air characteristics and the air permeability of the openings 67 in the molding member 62. With such processes occurring across a large number of the filaments and solid additives during laydown as described herein, the intensive properties of the regions may be established.

The layered scrim component/core component 26/24 and optionally scrim component 26 (fibrous structure 10) may then be subjected to pressure via a nip formed by two rolls 60 and/or plates. In one example, the nip is formed by a flat or even surface rubber roll and a flat or even surface, heated metal roll such that the fibrous structure 10 is deflected into the collection device 56, for example molding member 62. Alternatively, this step of subjecting the fibrous structure 10 to pressure via a nip formed by two rolls or plates could be done as a step after removal from the collection device 56. Or, the step of subjecting the fibrous structure 10 to pressure via a nip formed by two rolls or plates after removal from the collection device 56 does not need to be done.

The collection device 56, for example the molding member 62 may comprise a polymer resin 66 arranged to impart a three-dimensional pattern to the fibrous structure 10 being formed thereon and/or to components of the fibrous structure 10, such as scrim components 26 and core components 24. The collection device 56 may be a patterned molding member 62 that results in

the fibrous structure 10 exhibiting a surface pattern, such as a non-random, repeating pattern. The patterned molding member 62 may have a three-dimensional pattern on it that gets imparted to the scrim components 26 and/or the core components 24 during the process. In one example, the solid additives 54 are wood pulp fibers, such as SSK fibers and/or Eucalyptus fibers, and the filaments 52 are polypropylene filaments. The solid additives 54 may be combined with the filaments 52, such as by being delivered to a stream of filaments 52 from a hammermill (not shown) via a solid additive delivery device (not shown) such as a fiber spreader and/or a forming head and/or eductor. The filaments 52 may be created by meltblowing from a meltblow die, for example as shown in Figs. 8 and 9.

10 In one example of the present invention, the core component 24 is made using a die 68, as shown in Figs. 8 and 9, comprising at least one filament-forming hole 70, and/or 2 or more and/or 3 or more rows of filament-forming holes 70 from which filaments 52 are spun. At least one row of holes contains 2 or more and/or 3 or more and/or 10 or more filament-forming holes 70. In addition to the filament-forming holes 70, the die 68 comprises fluid releasing holes 72, such as 15 gas-releasing holes, in one example air-releasing holes, that provide attenuation to the filaments formed from the filament-forming holes 70. One or more fluid releasing holes 72 may be associated with a filament-forming hole 70 such that the fluid exiting the fluid-releasing hole 70 is parallel or substantially parallel (rather than angled like a knife-edge die) to an exterior surface of a filament 52 exiting the filament-forming hole 70. In one example, the fluid exiting the fluid-releasing hole 72 contacts the exterior surface of a filament 52 formed from a filament-forming hole 70 at an angle of less than 30° and/or less than 20° and/or less than 10° and/or less than 5° and/or about 0°. One or more fluid-releasing holes 72 may be arranged around a filament-forming hole 70. In one example, one or more fluid-releasing holes 36 are associated with a single filament-forming hole 70 such that the fluid exiting the one or more fluid-releasing holes 72 contacts the 25 exterior surface of a single filament 52 formed from the single filament-forming hole 70. In one example, the fluid-releasing hole 70 permits a fluid, such as a gas, for example air, to contact the exterior surface of a filament 52 formed from a filament-forming hole 70 rather than contacting an inner surface of a filament 52, such as what happens when a hollow filament is formed.

30 In one example, the die 68 comprises a filament-forming hole 70 positioned within a fluid-releasing hole 72. The fluid-releasing hole 72 may be concentrically or substantially concentrically positioned around a filament-forming hole 70 such as is shown in Figs. 8 and 9.

In another example, the die 68 comprises filament-forming holes 70 and fluid-releasing holes 72 arranged to produce a plurality of filaments 52 that exhibit a broader range of filament diameters than known filament-forming hole 70 dies, such as knife-edge dies.

In still another example, the die comprises a knife-edge die.

The process of the present invention may include preparing individual rolls of fibrous structure that are suitable for consumer use. The fibrous structure may be contacted by a bonding agent (such as an adhesive and/or dry strength agent), such that the ends of a roll of sanitary tissue product according to the present invention comprise such adhesive and/or dry strength agent.

In one example, the fibrous structures are embossed and/or cut into sheets, and collected in stacks of fibrous structures.

The process of the present invention may include preparing individual rolls and/or sheets and/or stacks of sheets of fibrous structures that are suitable for consumer use.

In one example, one or more of the components of the fibrous structure may be made individually and then combined with one or more other components and/or other fibrous structures. In another example, two or more of the fibrous structures of the present invention may be combined with each other and/or with another fibrous structure to form a multi-ply fibrous structure.

The continuous polymer filament diameter distribution of all the components involved can be controlled by adjusting the attenuation process levers. These levers include, but are not limited to, the mass throughput ratio of attenuation fluid to polymer melt, the temperature of the attenuation fluid and polymer melt, spinning nozzle orifice size, polymer melt rheological properties, and polymer melt quenching. In one example, the polymer melt attenuation process can use a jet-to-melt mass ratio between 0 and 27. In another example, the polymer melt is extruded at 350°F while the attenuation fluid was injected at 395°F. In two similar examples, polymer melt is either extruded through a 0.018" orifice diameter or a 0.015" orifice diameter at the same jet-to-melt mass ratio and temperature. In yet another example, different melt flow rate (MFR) combinations of isotactic polypropylene resins can be extruded. In still another example, cold air at 73°F and four times more than the attenuation air by mass is injected into the forming zone and impinges the attenuation jet to drastically decrease polymer and air temperature.

Each fibrous structure can have either the same or different fiber diameter distribution as the other fibrous structures. In one example having a three-ply fibrous structure, the two plies sandwiching the center ply can have larger mean filament diameter with the same or different filament diameter distribution to provide more surface roughness. In a variation of the previous example, only one of the outer plies has a larger mean filament diameter with the same or different filament diameter distribution as the core ply, while the other outer ply has a smaller mean filament diameter with the same or different filament diameter distribution as the core ply. In another example involving a one-ply fibrous structure, the mean meltblown filament diameter is increased to provide scaffold structure for larger void space.

The process for making fibrous structure 10 may be close coupled (where the fibrous structure is convolutedly wound into a roll prior to proceeding to a converting operation) or directly coupled (where the fibrous structure is not convolutedly wound into a roll prior to proceeding to a converting operation) with a converting operation to emboss, print, deform, surface treat, thermal bond, cut, stack or other post-forming operation known to those in the art. For purposes of the present invention, direct coupling means that the fibrous structure 10 can proceed directly into a converting operation rather than, for example, being convolutedly wound into a roll and then unwound to proceed through a converting operation.

Molding Members

10 The fibrous structures of the present invention may be formed on molding members, for example a patterned molding member, that result in the fibrous structures of the present invention. In one example, the pattern molding member comprises a non-random repeating pattern. In another example, the pattern molding member comprises a resinous pattern.

15 A “reinforcing element” may be a desirable (but not necessary) element in some examples of the molding member, serving primarily to provide or facilitate integrity, stability, and durability of the molding member comprising, for example, a resinous material. The reinforcing element can be fluid-permeable or partially fluid-permeable, may have a variety of embodiments and weave patterns, and may comprise a variety of materials, such as, for example, a plurality of interwoven yarns (including Jacquard-type and the like woven patterns), a felt, a plastic, other suitable
20 synthetic material, or any combination thereof.

Products Comprising Fibrous Structures

The fibrous structures of the present invention may be used as and/or incorporated into various products, for example consumer products. Non-limiting examples of such products include wipes, for example wet wipes, such as baby wipes, adult wipes, facial cleaning wipes, and/or hard surface cleaning wipes, cleaning pads/sheets, for example floor cleaning pads, both
25 and wet and those used with liquid cleaning compositions and/or water, paper towels and other dry cleaning disposable products, such as disposable dish cloths, and facial tissues.

Cleaning Pads/Sheets

The fibrous structures of the present invention may be used as and/or incorporated into
30 cleaning pads and/or cleaning sheets, such as floor cleaning pads, for use alone or with an implement.

The cleaning pad or sheet may exhibit a basis weight of from about 20 gsm to about 1000 gsm and/or from about 30 gsm to about 500 gsm and/or from about 60 gsm to about 300 gsm and/or from about 75 gsm to about 200 gsm and/or from about 100 gsm to about 200 gsm.

The cleaning pad or sheet may comprise one or more additives to improve cleaning performance and/or enhance the cleaning experience. Non-limiting examples of suitable additives include waxes, such as microcrystalline wax, oils, adhesives, perfumes, and combinations thereof.

If desired, the cleaning pad or sheet may be pre-moistened. The cleaning pad or sheet may be pre-moistened with a liquid composition that provides for cleaning of the target surface, such as a floor, but yet does not require a post-cleaning rinsing operation. When pre-moistened, the cleaning pad or sheet may be loaded with at least 3 and/or 4 and/or 5 grams of a liquid composition, such as a cleaning solution, per gram of dry fibrous structure, for example dry cleaning pad or sheet, but typically not more than 10 and/or not more than 8.5 and/or not more than 7.5 grams per gram. The liquid, for example cleaning solution, may comprise a surfactant, such as APG surfactant which minimizes streaking since there is typically not a rinsing operation, agglomerating chemicals, disinfectants, bleaching solutions, perfumes, secondary surfactants, and combinations thereof. A suitable pre-moistened cleaning pad or sheet may be pre-moistened according to the teachings of commonly assigned U.S. Patent No. 6,716,805.

The cleaning pad or sheet may comprise a plurality of layers to provide for scrubbing, for example provides for more aggressive cleaning of the target surface, liquid storage, and other particularized tasks for the cleaning operation. For example, a scrubby material, such as in the form of a strip, may be added to a surface of the fibrous structure to provide a scrubby surface or portion of a surface on the cleaning pad or sheet. A non-limiting example of a suitable scrubbing material or strip may comprise a polyolefinic film, such as LDPE, and may have outwardly extending perforations. The scrubbing strip may be made and used according to commonly assigned U.S. Patent Nos. 8,250,700; 8,407,848; D551,409 S and/or D614,408 S.

The cleaning pad or sheet according to the present invention may be used with a stick-type cleaning implement. The cleaning implement may comprise a plastic head for holding the cleaning sheet and an elongate handle articulably connected thereto. The handle may comprise a metal or plastic tube or solid rod.

The head may have a downwardly facing surface, to which the cleaning pad or sheet may be attached. The downwardly facing surface may be generally flat, or slightly convex. The head may further have an upwardly facing surface. The upwardly facing surface may have a universal joint to facilitate connection of the elongate handle to the head.

A hook and loop system may be used to attach the cleaning pad or sheet directly to the bottom of the head. Alternatively, the upwardly facing surface may further comprise a mechanism, such as resilient grippers, for removably attaching the cleaning pad or sheet to the implement. Alternatively, a hook and loop system may be used to attach the cleaning pad or sheet to the head.

If grippers are used with the cleaning implement, the grippers may be made according to commonly assigned U.S. Patent Nos. 6,305,046; 6,484,346; 6,651,290 and/or D487,173.

If desired, the cleaning implement may have an axially rotatable beater bar and/or vacuum type suction to assist in removal of debris from the target surface. Debris removed from the target surface may be collected in a dust bin. The dust bin may be mounted within the head, or, alternatively, on the elongate handle. A suitable stick-type cleaning implement may be made according to commonly assigned US Patent Des. Nos. D391,715; D409,343; D423,742; D481,184; D484,287; D484,287 and/or D588,770. A suitable vacuum type cleaning implement may be made according to the teachings of U.S. Patent Nos. 7,137,169, D484,287 S, D615,260 S and D615,378 S. An implement having a beater bar may be made according to commonly assigned U.S. Published Patent Application No. 2013/0333129. A motorized implement may be made according to commonly assigned U.S. Patent No. 7,516,508.

The cleaning implement may further comprise a reservoir for storage of a cleaning solution. The reservoir may be replaced when the cleaning solution is depleted and/or refilled as desired. The reservoir may be disposed on the head or the handle of the cleaning implement. The neck of the reservoir may be offset per commonly assigned U.S. Patent No. 6,390,335. The cleaning solution contained therein may be made according to the teachings of commonly assigned U.S. Patent No. 6,814,088.

The cleaning implement may further comprise a pump for dispensing cleaning solution from the reservoir onto the target surface, such as a floor. The pump may be battery powered or operated by line voltage. Alternatively, the cleaning solution may be dispensed by gravity flow. The cleaning solution may be sprayed through one or more nozzles to provide for distribution of the cleaning solution onto the target surface in an efficacious pattern.

If a replaceable reservoir is utilized, the replaceable reservoir may be inverted to provide for gravity flow of the cleaning solution. Or the cleaning solution may be pumped to the dispensing nozzles. The reservoir may be a bottle, and may be made of plastic, such as a polyolefin. The cleaning implement may have a needle to receive the cleaning solution from the bottle. The bottle may have a needle piercable membrane, complementary to the needle, and which is resealed to prevent undesired dripping of the cleaning solution during insertion and removal of the replaceable reservoir. Alternatively or additionally, If desired, the implement may also provide for steam to be delivered to the cleaning pad or sheet and/or to the floor or other target surface.

A suitable reservoir and fitment therefor may be made according to the teachings of commonly assigned U.S. Patent Nos. 6,386,392, 7,172,099; D388,705; D484,804; D485,178. A suitable cleaning implement may be made according to the teachings of commonly assigned U.S.

Patent Nos. 5,888,006; 5,960,508; 5,988,920; 6,045,622; 6,101,661; 6,142,750; 6,579,023; 6,601,261; 6,722,806; 6,766,552; D477,701 and/or D487,174. A steam implement may be made according to the teachings of jointly assigned U.S. Published Patent Application No. 2013/0319463.

5 The cleaning pad or sheet may comprise layers, to provide for absorption and storage of cleaning solution deposited on the target surface. If desired, the cleaning pad or sheet may comprise superabsorbent materials to increase the absorbent capacity of the cleaning pad or sheet. The superabsorbent materials may be distributed within the cleaning pad or sheet in such a manner to avoid rapid absorbency and absorb fluids slowly, to provide for the most effective use of the
10 cleaning pad or sheet.

 The cleaning pad or sheet may comprise plural layers disposed in a laminate. The lowest, or downwardly facing outer layer, may comprise apertures to allow for absorption of cleaning solution therethrough and to promote the scrubbing of the target surface. Intermediate layers may provide for storage of the liquids, and may comprise the superabsorbent materials. The cleaning
15 pad or sheet may have an absorbent capacity of at least 10, 15, or 20 grams of cleaning solution per gram of dry cleaning pad or sheet, as set forth in commonly assigned U.S. Patent Nos. 6,003,191 and 6,601,261.

 The top or upwardly facing outer layer of the cleaning pad or sheet (for example, the surface that contacts the cleaning implement), maybe liquid impervious in order to minimize loss of
20 absorbed fluids. The top layer may further provide for releasable attachment of the cleaning pad or sheet to a cleaning implement. The top layer may be made of a polyolefinic film, such as LDPE.

 The fibrous structures of the present invention may be cut to provide strips or portions of strips to form a cleaning article. The fibrous structure and/or strips thereof may comprise an additive to assist in removal of dust and other debris from a target surface, such as a hard surface,
25 for example a coffee table, mantle, and the like. The additive may comprise waxes, such as microcrystalline wax, oils, adhesives and combinations thereof. The cleaning article may be made according to U.S. Patent No. 6,813,801. The cleaning article may accept one or more complementary fork tines of a handle. The fork tines may be removably inserted into the cleaning article or sleeves formed on the cleaning article to provide for improved ergonomics. The handle
30 may be plastic and made according to the teachings of U.S. Patent Nos. 7,219,386; 7,293,317 and/or 7,383,602.

Non-limiting Examples of Fibrous Structures of the Present InventionProcess Example 1 - Process for Making a Two Layer Fibrous Structure of the Present Invention

A 21%:27.5%:47.5%:4% blend of Lyondell-Basell PH835 polypropylene : Lyondell-Basell Metocene MF650W polypropylene : Lyondell-Basell Metocene MF650X : Ampacet 412951
5 opacifier is dry blended, to form a melt blend. A meltblown layer of the meltblown filaments, such as a scrim component, is produced first. This addition of the meltblown scrim component layer can help reduce the lint created from the fibrous structure during use by consumers and is preferably performed prior to any thermal bonding operation of the fibrous structure. The scrim layer can be the same or different than the meltblown filaments in the center formed fibrous
10 structure. To make the meltblown filaments for the exterior layers, A 15.5 inch wide Biax 12 row spinnerette with 192 nozzles per cross-direction inch, commercially available from Biax Fiberfilm Corporation, is utilized. 32 nozzles per cross-direction inch of the 192 nozzles have a 0.018 inch inside diameter while the remaining nozzles are solid, i.e. there is no opening in the nozzle. Approximately 0.2 grams per hole per minute (ghm) of the melt blend is extruded from the open
15 nozzles to form meltblown filaments from the melt blend. Approximately 472 SCFM of compressed air, equivalent to a jet-to-melt mass ratio of 26, is heated such that the air exhibits a temperature of about 395°F at the spinnerette. A forming vacuum pulls air through a collection device, such as a non-patterned forming belt or through-air-drying fabric, thus collecting the meltblown filaments to form a fibrous structure.

20 A 20%:27.5%:47.5%:5% blend of Lyondell-Basell PH835 polypropylene : Lyondell-Basell Metocene MF650W polypropylene : Lyondell-Basell Metocene MF650X : Polyvel S1416 wetness agent is dry blended, to form a melt blend. The melt blend is heated to 400°F through a melt extruder. A 15.5 inch wide Biax 12 row spinnerette with 192 nozzles per cross-direction inch, commercially available from Biax Fiberfilm Corporation, is utilized. 24 nozzles per cross-
25 direction inch of the 192 nozzles have a 0.018 inch inside diameter while the remaining nozzles are solid, i.e. there is no opening in the nozzle. Approximately 0.5 grams per hole per minute (ghm) of the melt blend is extruded from the open nozzles to form meltblown filaments from the melt blend. Approximately 320 SCFM of compressed air, equivalent to a jet-to-melt mass ratio of 7, is heated such that the air exhibits a temperature of about 395°F at the
30 spinnerette. Approximately 750 g/minute of Golden Isle (from Georgia Pacific) 4725 semi-treated SSK pulp is defibrillated through a hammermill to form SSK wood pulp fibers (solid additive). Air at a temperature of about 85 to 90°F and about 80% relative humidity (RH) is drawn into the hammermill. Approximately 35 kg/min of air split into two symmetric streams carry the pulp fibers to a solid additive spreader. The solid additive spreader turns the pulp fibers and

distributes the pulp fibers in the cross-direction such that the pulp fibers are injected into the meltblown filaments at a 45° angle (with respect to the flow of the meltblown filaments). A forming box surrounds the area where the meltblown filaments and pulp fibers are commingled. This forming box is designed to reduce the amount of air allowed to enter or escape from this commingling area. A forming vacuum pulls air through a collection device, such as a patterned belt carrying the first scrim layer, thus collecting the commingled meltblown filaments and pulp fibers to form a fibrous structure comprising a pattern of non-random, repeating microregions of differing intensive properties and an exterior scrim layer. The fibrous structure formed by this process comprises about 80% by dry fibrous structure weight of pulp and about 20% by dry fibrous structure weight of meltblown filaments.

Another meltblown layer of the meltblown filaments using the same melt blend as the first scrim layer, is added to the opposite side of the above formed fibrous structure. This scrim layer can be the same or different than the meltblown filaments in the center formed fibrous structure or from the scrim on the opposite side. This scrim layer can be used as a process aid to prevent linting during substrate making. To make the meltblown filaments for this exterior layer, A 15.5 inch wide Biax 12 row spinnerette with 192 nozzles per cross-direction inch, commercially available from Biax Fiberfilm Corporation, is utilized. 8 nozzles per cross-direction inch of the 192 nozzles have a 0.018 inch inside diameter while the remaining nozzles are solid, i.e. there is no opening in the nozzle. Approximately 0.18 grams per hole per minute (ghm) of the melt blend is extruded from the open nozzles to form meltblown filaments from the melt blend. Approximately 426 SCFM of compressed air, equivalent to a jet-to-melt mass ratio of 26, is heated such that the air exhibits a temperature of about 395°F at the spinnerette. A forming vacuum pulls air through a collection device, such as a non-patterned forming belt or through-air-drying fabric, thus collecting the meltblown filaments to form a fibrous structure on top of the above formed fibrous structure.

The combined structure above can be calendared on the forming fabric to create even more distinct regions of differing intensive properties. The fibrous structure may be convolutedly wound to form a roll of fibrous structure.

At least two such roll of fibrous structures can be laminated using adhesive or mechanical bonding to create at least two or more plies structures. In this example, two rolls of the fibrous structures above formed on patterned fabric are unwound such that the patterning sides are facing away. A Nordson adhesive applicator with summit nozzles added 12 gsm of Bostik H2031 adhesive at 170°C onto the non-patterned side of one of the fibrous structure. The glued fibrous structure is laminated to the non-patterned side of the other fibrous structure, and the combined

fibrous structure is then send through a nip roll to set the adhesive bond and convolutedly wound to form a roll of fibrous structure.

Process Example 2 - Process for Making Macro-Micro Fibrous Structure of the Present Invention

Making of a multi-ply structure, including at least one scrim layer, with macro and micro scale repeating features, is described in this example.

A 21%:27.5%47.5%:4% blend of Lyondell-Basell PH835 polypropylene: Lyondell-Basell Metocene MF650W polypropylene: Lyondell-Basell Metocene MF650X: Ampacet 412951 opacifier is dry blended, to form a melt blend. A meltblown layer of the meltblown filaments, such as a scrim component, is produced first. To make the meltblown filaments of the scrim component, a 15.5 inch wide Biax 12 row spinnerette with 192 nozzles per cross-direction inch, commercially available from Biax Fiberfilm Corporation, is utilized. 32 nozzles per cross-direction inch of the 192 nozzles have a 0.018 inch inside diameter while the remaining nozzles are solid, i.e. there is no opening in the nozzle. Approximately 0.2 grams per hole per minute (ghm) of the melt blend is extruded from the open nozzles to form meltblown filaments from the melt blend. Approximately 472 SCFM of compressed air, equivalent to a jet-to-melt mass ratio of 26, is heated such that the air exhibits a temperature of about 395°F at the spinnerette. A forming vacuum operating at 23 mBar pressure pulls air through a collection device, such as a non-macro patterned, weaved forming belt of air permeability of 700 SCFM, thus collecting the meltblown filaments to form a fibrous structure that conforms to the micro texture from the weaving pattern of the collection device. The collection device can also have macro patterns, in which meltblown filaments will first conform to the macro patterns of the collection device, and then conform to the micro weave texture of the reinforcing element of the collection device.

A 20%:27.5%47.5%:5% blend of Lyondell-Basell PH835 polypropylene : Lyondell-Basell Metocene MF650W polypropylene : Lyondell-Basell Metocene MF650X : Polyvel S1416 wetness agent is dry blended, to form a melt blend. The melt blend is heated to 400°F through a melt extruder. A 15.5 inch wide Biax 12 row spinnerette with 192 nozzles per cross-direction inch, commercially available from Biax Fiberfilm Corporation, is utilized. 24 nozzles per cross-direction inch of the 192 nozzles have a 0.018 inch inside diameter while the remaining nozzles are solid, i.e. there is no opening in the nozzle. Approximately 0.5 grams per hole per minute (ghm) of the melt blend is extruded from the open nozzles to form meltblown filaments from the melt blend. Approximately 320 SCFM of compressed air, equivalent to a jet-to-melt mass ratio of 7, is heated such that the air exhibits a temperature of about 395°F at the spinnerette. Approximately 750 g/minute of Golden Isle (from Georgia Pacific) 4725 semi-treated SSK pulp is defibrillated through a hammermill to form SSK wood pulp fibers (solid

additive). Air at a temperature of about 85 to 90°F and about 80% relative humidity (RH) is drawn into the hammermill. Approximately 35 kg/min of air split into two symmetric streams carry the pulp fibers to a solid additive spreader. The solid additive spreader turns the pulp fibers and distributes the pulp fibers in the cross-direction such that the pulp fibers are injected into the meltblown filaments at a 45° angle (with respect to the flow of the meltblown filaments). A forming box surrounds the area where the meltblown filaments and pulp fibers are commingled. This forming box is designed to reduce the amount of air allowed to enter or escape from this commingling area. A forming vacuum pulls air through the same collection device carrying the first said scrim layer, thus collecting the commingled meltblown filaments and pulp fibers to form a fibrous structure on top of the patterned scrim layer (scrim component). The fibrous structure formed by this process comprises about 80% by dry fibrous structure weight of pulp and about 20% by dry fibrous structure weight of meltblown filaments.

After the fibrous structure, with additional meltblown filaments (scrim layers) has been formed on the collection device, the fibrous structure is calendared at elevated temperature, while the fibrous structure is still on the collection device. In this example, the fibrous structure with meltblown filaments on the patterned side, is calendared while on the collection device with macro pattern and micro weave pattern at about 240 PLI (Average pounds per linear CD inch across the patterned molding member CD width of 21”) with a flat or even surface metal anvil roll facing the fibrous structure and a flat or even surface rubber coated roll facing the patterned molding member. The metal anvil roll has an internal temperature of 290°F as supplied by an oil heater.

After the fibrous structure is collected in roll form, it is further converted by being lotioned and cut to form a finished product.

Process Example 3 - Process for Making Macro-Micro Textured Fibrous Structure On Patterned Molding Member of the Present Invention

Making of a multi-ply structure, including at least one scrim layer (scrim component), with macro and micro scale repeating features, is described in this example.

A 21%:27.5%:47.5%:4% blend of Lyondell-Basell PH835 polypropylene: Lyondell-Basell Metocene MF650W polypropylene: Lyondell-Basell Metocene MF650X: Ampacet 412951 opacifier is dry blended, to form a melt blend. A meltblown layer of the meltblown filaments, such as a scrim component, is produced first. To make the meltblown filaments for the scrim component, a 15.5 inch wide Biax 12 row spinnerette with 192 nozzles per cross-direction inch, commercially available from Biax Fiberfilm Corporation, is utilized. 32 nozzles per cross-direction inch of the 192 nozzles have a 0.018 inch inside diameter while the remaining nozzles are solid, i.e. there is no opening in the nozzle. Approximately 0.2 grams per hole per minute

(ghm) of the melt blend is extruded from the open nozzles to form meltblown filaments from the melt blend. Approximately 472 SCFM of compressed air, equivalent to a jet-to-melt mass ratio of 26, is heated such that the air exhibits a temperature of about 395°F at the spinnerette. A forming vacuum operating at 23 mBar pressure pulls air through a collection device, such as a non-macro patterned, weaved forming belt of air permeability of 700 SCFM, thus collecting the meltblown filaments to form a fibrous structure that conforms to the micro texture from the weaving pattern of the collection device. The collection device can also have macro patterns, in which meltblown filaments will first conform to the macro patterns of the collection device, and then conform to the micro weave texture of the reinforcing element of the collection device.

10 A 20%:27.5%47.5%:5% blend of Lyondell-Basell PH835 polypropylene : Lyondell-Basell Metocene MF650W polypropylene : Lyondell-Basell Metocene MF650X : Polyvel S1416 wetness agent is dry blended, to form a melt blend. The melt blend is heated to 400°F through a melt extruder. A 15.5 inch wide Biax 12 row spinnerette with 192 nozzles per cross-direction inch, commercially available from Biax Fiberfilm Corporation, is utilized. 24 nozzles per cross-
15 direction inch of the 192 nozzles have a 0.018 inch inside diameter while the remaining nozzles are solid, i.e. there is no opening in the nozzle. Approximately 0.5 grams per hole per minute (ghm) of the melt blend is extruded from the open nozzles to form meltblown filaments from the melt blend. Approximately 320 SCFM of compressed air, equivalent to a jet-to-melt mass ratio of 7, is heated such that the air exhibits a temperature of about 395°F at the
20 spinnerette. Approximately 750 g/minute of Golden Isle (from Georgia Pacific) 4725 semi-treated SSK pulp is defibrillated through a hammermill to form SSK wood pulp fibers (solid additive). Air at a temperature of about 85 to 90°F and about 80% relative humidity (RH) is drawn into the hammermill. Approximately 35 kg/min of air split into two symmetric streams carry the pulp fibers to a solid additive spreader. The solid additive spreader turns the pulp fibers and
25 distributes the pulp fibers in the cross-direction such that the pulp fibers are injected into the meltblown filaments at a 45° angle (with respect to the flow of the meltblown filaments). A forming box surrounds the area where the meltblown filaments and pulp fibers are commingled. This forming box is designed to reduce the amount of air allowed to enter or escape from this commingling area. A forming vacuum pulls air through the same collection device carrying the first said scrim layer, thus collecting the commingled meltblown filaments and pulp
30 fibers to form a fibrous structure on top of the patterned scrim layer (scrim component). The fibrous structure formed by this process comprises about 80% by dry fibrous structure weight of pulp and about 20% by dry fibrous structure weight of meltblown filaments.

A third layer composed of the identical formulation as the first said scrim can be added to the opposite side of the co-formed layer, thus encapsulating the co-form pulp core to prevent linting. To make the meltblown filaments for this exterior layer, A 15.5 inch wide Biax 12 row spinnerette with 192 nozzles per cross-direction inch, commercially available from Biax Fiberfilm Corporation, is utilized. 8 nozzles per cross-direction inch of the 192 nozzles have a 0.018 inch inside diameter while the remaining nozzles are solid, i.e. there is no opening in the nozzle. Approximately 0.18 grams per hole per minute (ghm) of the melt blend is extruded from the open nozzles to form meltblown filaments from the melt blend. Approximately 425 SCFM of compressed air, equivalent to a jet-to-melt mass ratio of 26, is heated such that the air exhibits a temperature of about 395°F at the spinnerette. A forming vacuum operating at 23 mBar pressure pulls air through the same collection device carrying the first said scrim layer and said co-form layer, thus collecting the commingled meltblown filaments to form a fibrous structure opposite side of the first said scrim layer.

After the fibrous structure, with additional meltblown filaments (scrim layers) has been formed on the collection device, such as a patterned molding member, the fibrous structure is calendered at elevated temperature, while the fibrous structure is still on the collection device. In this example, the fibrous structure with the first said scrim side facing the macro patterned molding member with micro weave pattern, is calendared. About 240 PLI (Average pounds per linear CD inch across the patterned molding member CD width of 21") was applied with a flat or even surface metal anvil roll facing the fibrous structure and a flat or even surface rubber coated roll facing the patterned molding member. The metal anvil roll has an internal temperature of 290°F as supplied by an oil heater.

The fibrous structure may be convolutedly wound to form a roll of fibrous structure. After the fibrous structure is collected in roll form, it is further converted by being lotioned and cut to form a finished product.

Process Example 4 - Process for Making Emboss Macro Texture with Micro Surface Protrusion Fibrous Structure of the Present Invention

Making of a multi-ply structure, including at least one scrim layer (scrim component), with embossed macro texture and micro surface protrusion features, is described in this example.

A 21%:27.5%:47.5%:4% blend of Lyondell-Basell PH835 polypropylene: Lyondell-Basell Metocene MF650W polypropylene: Lyondell-Basell Metocene MF650X: Ampacet 412951 opacifier is dry blended, to form a melt blend. A meltblown layer of the meltblown filaments, such as a scrim component, is produced first. To make the meltblown filaments for the scrim

component, a 15.5 inch wide Biax 12 row spinnerette with 192 nozzles per cross-direction inch, commercially available from Biax Fiberfilm Corporation, is utilized. 32 nozzles per cross-direction inch of the 192 nozzles have a 0.018 inch inside diameter while the remaining nozzles are solid, i.e. there is no opening in the nozzle. Approximately 0.2 grams per hole per minute (ghm) of the melt blend is extruded from the open nozzles to form meltblown filaments from the melt blend. Approximately 472 SCFM of compressed air, equivalent to a jet-to-melt mass ratio of 26, is heated such that the air exhibits a temperature of about 395°F at the spinnerette. A forming vacuum operating at 23 mBar pressure pulls air through a collection device, such as a weaved forming belt Velostat 170PC 740 fabric by Albany International, thus collecting the meltblown filaments to form a fibrous structure that conforms to the micro texture from the weaving pattern of the collection device's reinforcing element.

A 20%:27.5%:47.5%:5% blend of Lyondell-Basell PH835 polypropylene : Lyondell-Basell Metocene MF650W polypropylene : Lyondell-Basell Metocene MF650X : Polyvel S1416 wetness agent is dry blended, to form a melt blend. The melt blend is heated to 400°F through a melt extruder. A 15.5 inch wide Biax 12 row spinnerette with 192 nozzles per cross-direction inch, commercially available from Biax Fiberfilm Corporation, is utilized. 24 nozzles per cross-direction inch of the 192 nozzles have a 0.018 inch inside diameter while the remaining nozzles are solid, i.e. there is no opening in the nozzle. Approximately 0.5 grams per hole per minute (ghm) of the melt blend is extruded from the open nozzles to form meltblown filaments from the melt blend. Approximately 320 SCFM of compressed air, equivalent to a jet-to-melt mass ratio of 7, is heated such that the air exhibits a temperature of about 395°F at the spinnerette. Approximately 750 g/minute of Golden Isle (from Georgia Pacific) 4725 semi-treated SSK pulp is defibrillated through a hammermill to form SSK wood pulp fibers (solid additive). Air at a temperature of about 85 to 90°F and about 80% relative humidity (RH) is drawn into the hammermill. Approximately 35 kg/min of air split into two symmetric streams carry the pulp fibers to a solid additive spreader. The solid additive spreader turns the pulp fibers and distributes the pulp fibers in the cross-direction such that the pulp fibers are injected into the meltblown filaments at a 45° angle (with respect to the flow of the meltblown filaments). A forming box surrounds the area where the meltblown filaments and pulp fibers are commingled. This forming box is designed to reduce the amount of air allowed to enter or escape from this commingling area. A forming vacuum operating at 48 mBar pressure pulls air through the same collection device carrying the first said scrim layer, thus collecting the commingled meltblown filaments and pulp fibers to form a fibrous structure on top of the pattern scrim

layer. The fibrous structure formed by this process comprises about 80% by dry fibrous structure weight of pulp and about 20% by dry fibrous structure weight of meltblown filaments.

A third layer composed of the identical formulation as the first said scrim can be added to the opposite side of the co-formed layer, thus encapsulating the co-form pulp core to prevent
5 linting. To make the meltblown filaments for this exterior layer, A 15.5 inch wide Biax 12 row spinnerette with 192 nozzles per cross-direction inch, commercially available from Biax Fiberfilm Corporation, is utilized. 8 nozzles per cross-direction inch of the 192 nozzles have a 0.018 inch inside diameter while the remaining nozzles are solid, i.e. there is no opening in the nozzle. Approximately 0.18 grams per hole per minute (ghm) of the melt blend is extruded from the open
10 nozzles to form meltblown filaments from the melt blend. Approximately 425 SCFM of compressed air, equivalent to a jet-to-melt mass ratio of 26, is heated such that the air exhibits a temperature of about 395°F at the spinnerette. A forming vacuum operating at 23 mBar pressure pulls air through the same collection device carrying the first said scrim layer and said co-form layer, thus collecting the commingled meltblown filaments to form a fibrous structure opposite
15 side of the first said scrim layer.

After the fibrous structure, with additional meltblown filaments (scrim layers) has been formed on the collection device, the fibrous structure is embossed at elevated temperature. In this example, the fibrous structure side with the first said scrim meltblown layer is facing the patterned roll during emboss operation. About 240 PLI (Average pounds per linear CD inch across the
20 patterned molding member CD width of 21") was applied with a flat or even surface metal anvil roll facing the opposite side of the fibrous structure. The metal anvil roll has an internal temperature of 290°F as supplied by an oil heater.

The fibrous structure may be convolutedly wound to form a roll of fibrous structure. After the fibrous structure is collected in roll form, it is further converted by being lotioned and cut to
25 form a finished product.

Test Methods

Unless otherwise specified, all tests described herein including those described under the Definitions section and the following test methods are conducted on samples that have been
30 conditioned in a conditioned room at a temperature of 23°C ± 1.0°C and a relative humidity of 50% ± 2% for a minimum of 12 hours prior to the test. Except where noted all tests are conducted in such conditioned room, all tests are conducted under the same environmental conditions and in such conditioned room. Discard any damaged product. Do not test samples that have defects such

as wrinkles, tears, holes, and like. All instruments are calibrated according to manufacturer's specifications.

Mileage Test Method

5 Mileage of a pre-moistened fibrous structure, for example a pre-moistened floor cleaning pad, is measured as coverage area of the liquid composition distributed on a floor surface. If the pre-moistened fibrous structure is in a package, open the package and remove the pre-moistened wipe, ensuring that the pre-moistened wipe is not subjected to pressure, such as squeezing, that would cause the liquid composition to be expressed from the pre-moistened wipe. If the pre-moistened wipe is in a stack within a package, open the package and remove a pre-moistened wipe from the middle of the stack, again ensuring that the pre-moistened wipe is not subjected to pressure, such as squeezing, that would cause the liquid composition to be expressed from the pre-moistened wipe. This Mileage test is conducted in temperature (70°F) and humidity (45% RH) controlled room. The room should be well-lit to assist visual assessment of liquid distribution. A matte black tile floor (such as Sierra Field Tile in plain black 12 inch square) is chosen to conduct the testing to further assist the observation of streak appearance.

A mop sled is constructed from aluminum frame, Teflon bars, velcro and Swiffer® Sweeper handle, which holds a Swiffer® Sweeper head in place during mopping and guides the head on the floor.

20 A mop head is modified by cutting off most of the Swiffer® Sweeper handle, leaving 10 inch bottom part of the handle. During testing, a known weight is put on the mop head to assert constant pressure on the test sample. Because the tester is holding the handle of the sled, no additional pressure is asserted on the wipe sample.

25 Clean the floor with a 20% IPA and 80% water solution. Spray the solution onto the floor liberally and use a squeegee to remove excess fluid. Let the floor dry completely before begin testing. The floor needs to be cleaned with the IPA/water mixture after every 3 testings or when switching test products to remove accumulation of cleaning lotion from wipes.

Record the weight of the modified mop head. Attach the pre-moistened fibrous structure to the modified mop head and record the weight. Calculate the difference of those two weights as "initial pad weight".

Place the mop head into the mopping sled and place 7.125 lbs weight with Velcro attachment onto the mop head. Making sure to not mop over an area more than once.

Start by mopping in the forward direction following the mopping pattern in Figure 11. The cadence (time) should be 1 second for the forward direction and 1 second for the backward

direction in an overlapping manner (See Figure 11 – arrows show direction of movement). Continue mopping until you have completed 80ft². Remove the weight from the mop head. It may take a while for the floor to be completely dry. Using Bounty towel drying the floor may significantly shorten the waiting time and decrease the amount of liquid loss due to evaporation from the testing subject. Once the floor is dry place the mop head with the substrate back into the mop sled and apply the weight. Continue to mop in the same fashion as stated previously. Continue mopping until streaks as shown in the 50% coverage image in Fig. 12 are visible to tester. This 50% coverage should be on both the forward and backstroke. Stop the test at this point by removing the pre-moistened fibrous structure from the floor surface. Record “final pad weight” and air drying the pre-moistened fibrous structure to remove any remaining liquid composition.

Calculate the surface area (ft²) that the liquid composition covered prior to stopping the test. This surface area (ft²) is used to calculate the mileage value of ft²/pre-moistened fibrous structure.

Once the fibrous structure is dry, the basis weight of the dried fibrous structure is measured according to the Basis Weight Test Method described herein. The surface area that the liquid composition covered (ft²) and the basis weight (in units of gsm) of the above dried fibrous structure are used to calculate the mileage value of ft²/gsm.

Prior to drying the pre-moistened fibrous structure, the surface area of the pre-moistened fibrous structure is measured (ft²). This surface area of the pre-moistened fibrous structure (ft²) and the surface area that liquid composition covered (ft²) is used to calculate the mileage value of ft²/ft² of the pre-moistened fibrous structure.

Fibrous Structure Basis Weight Test Method

Basis weight is measured prior to the application of any end-use lotion, cleaning solution, or other liquid composition, etc. to the fibrous structure or wipe, and follows a modified EDANA 40.3-90 (February 1996) method as described herein below.

1. Cut at least three test pieces of the fibrous structure or wipe to specific known dimensions using a pre-cut metal die and die press. Each test piece is cut to have an area of at least 0.01 m².
2. Use a balance to determine the mass of each test piece in grams; calculate basis weight (mass per unit area), in grams per square meter (gsm), using equation (1).

$$\text{Basis Weight} = \frac{\text{Mass of Test Piece (g)}}{\text{Area of Test Piece (m}^2\text{)}} \quad (1)$$

3. For a fibrous structure or wipe sample, report the numerical average basis weight for all test pieces.

4. If only a limited amount of the fibrous structure or wipe is available, basis weight may be measured and reported as the basis weight of one test piece, the largest rectangle possible.

5. If measuring a core layer, a scrim layer, or a combination of core and scrim layers, the respective layer is collected during the making operation without the other layers and then the
5 basis weight of the respective layer is measured as outlined above.

Diameter Test Method

The diameter of a filament, discrete or within a fibrous structure is determined by using a Scanning Electron Microscope (SEM) or an Optical Microscope and an image analysis software. A magnification of 200 to 10,000 times is chosen such that the filaments are suitably enlarged for
10 measurement. When using the SEM, the samples are sputtered with gold or a palladium compound to avoid electric charging and vibrations of the filaments in the electron beam. A manual procedure for determining the filament diameters is used from the image (on monitor screen) taken with the SEM or the optical microscope. Using a mouse and a cursor tool, the edge of a randomly selected filament is sought and then measured across its width (i.e., perpendicular to filament direction at
15 that point) to the other edge of the filament. A scaled and calibrated image analysis tool provides the scaling to get actual reading in μm . For filaments within a fibrous structure, several filaments are randomly selected across the sample of the fibrous structure using the SEM or the optical microscope. At least two portions of the fibrous structure are cut and tested in this manner. Altogether at least 100 such measurements are made and then all data are recorded for statistical
20 analysis. The recorded data are used to calculate average (mean) of the filament diameters, standard deviation of the filament diameters, and median of the filament diameters.

Another useful statistic is the calculation of the amount of the population of filaments that is below a certain upper limit. To determine this statistic, the software is programmed to count how many results of the filament diameters are below an upper limit and that count (divided by
25 total number of data and multiplied by 100%) is reported in percent as percent below the upper limit, such as percent below 1 micrometer diameter or %-submicron, for example. We denote the measured diameter (in μm) of an individual circular filament as d_i .

In the case that the filaments have non-circular cross-sections, the measurement of the filament diameter is determined as and set equal to the hydraulic diameter which is four times the
30 cross-sectional area of the filament divided by the perimeter of the cross-section of the filament (outer perimeter in case of hollow filaments). The number-average diameter, alternatively average diameter is calculated as:

$$d_{num} = \frac{\sum_{i=1}^n d_i}{n}$$

Liquid Absorptive Capacity Test Method

The following method, which is modeled after EDANA 10.4-02, is suitable to measure the Liquid Absorptive Capacity of any fibrous structure or wipe.

5 Prepare 4 samples of a pre-conditioned/conditioned fibrous structure or wipe for testing so that an average Liquid Absorptive Capacity of the 4 samples can be obtained. If the wipe is pre-moistured, lay the wipe on several layers of paper towel to drain the liquid overnight. All samples should be completely dry before testing.

Materials/Equipment

- 10 1. Flat stainless steel wire gauze sample holder with handle (commercially available from Humboldt Manufacturing Company) and flat stainless steel wire gauze (commercially available from McMaster-Carr) having a mesh size of 20 and having an overall size of at least 120 mm x 120 mm
- 15 2. Dish of size suitable for submerging the sample holder, with sample attached, in a test liquid, described below, to a depth of approximately 20 mm
3. Binder Clips (commercially available from Staples) to hold the sample in place on the sample holder
4. Ring stand
5. Balance, which reads to four decimal places
- 20 6. Stopwatch
7. Test liquid: deionized water (resistivity > 18 megaohms·cm)

Procedure

Prepare 4 samples of a fibrous structure or wipe for 4 separate Liquid Absorptive Capacity measurements. Individual test pieces are cut from the 4 samples to a size of approximately 50 mm
25 x 50 mm, and if an individual test piece weighs less than 1 gram, stack test pieces together to make sets that weigh at least 1 gram total. Fill the dish with a sufficient quantity of the test liquid described above, and allow it to equilibrate with room test conditions. Record the mass of the test piece(s) M_i for the first measurement before fastening the test piece(s) to the wire gauze sample holder described above with the clips. While trying to avoid the creation of air bubbles, submerge
30 the sample holder in the test liquid to a depth of approximately 20 mm and allow it to sit undisturbed for 60 seconds. After 60 seconds, remove the sample and sample holder from the test liquid. Remove all the binder clips but one, and attach the sample holder to the ring stand with the binder clip so that the sample may vertically hang freely and drain for a total of 20 seconds. After

the conclusion of the draining period, gently remove the sample from the sample holder and record the sample's mass M_X . Repeat for the remaining four test pieces or test piece sets.

Calculation of Liquid Absorptive Capacity

5 Liquid Absorptive Capacity is reported in units of grams of liquid composition per gram of the fibrous structure or wipe being tested. Liquid Absorptive Capacity is calculated as follows for each test that is conducted:

$$\text{Liquid Absorptive Capacity} = \frac{M_X - M_i}{M_i}$$

10 In this equation, M_i is the mass in grams of the test piece(s) prior to starting the test, and M_X is the mass in grams of the same after conclusion of the test procedure. Liquid Absorptive Capacity is typically reported as the numerical average of at least four tests per sample.

Capacity Test Method

15 Capacity of a pre-moistened fibrous structure, for example a pre-moistened floor cleaning pad, is measured as coverage area of the liquid composition distributed on a floor surface. If the pre-moistened fibrous structure is in a package, open the package and remove the pre-moistened wipe, ensuring that the pre-moistened wipe is not subjected to pressure, such as squeezing, that would cause the liquid composition to be expressed from the pre-moistened wipe. If the pre-moistened wipe is in a stack within a package, open the package and remove a pre-moistened wipe from the middle of the stack, again ensuring that the pre-moistened wipe is not subjected to
20 pressure, such as squeezing, that would cause the liquid composition to be expressed from the pre-moistened wipe. This Capacity test is conducted in a room that is void of air drafts or other wind that may cause the liquid composition present on a floor to evaporate more quickly than if the air drafts or wind was not present in the room.

25 A pre-moistened fibrous structure sample is attached to a Swiffer® Sweeper head. Immediately after attaching the pre-moistened fibrous structure sample, initiate mopping with an applied continued pressure of 0.1-0.3 psi a clean, new ceramic floor surface (at least 900 ft²) in the pattern as shown in Fig. 11 making sure to not mop over an area more than once. Use a metronome at 40 bpm to control stroke duration – each beat represents one direction. Continue mopping until streaks as shown in the 50% coverage image in Fig. 12 are visible to tester. Stop the test at this
30 point by removing the pre-moistened fibrous structure from the floor surface and air drying the pre-moistened fibrous structure to remove any remaining liquid composition.

Calculate the surface area (ft^2) that the liquid composition covered prior to stopping the test. This surface area (ft^2) is used to calculate the capacity value of $\text{ft}^2/\text{pre-moistened fibrous structure}$.

5 Once the fibrous structure is dry, the basis weight of the dried fibrous structure is measured according to the Basis Weight Test Method described herein. The surface area that the liquid composition covered (ft^2) and the basis weight (in units of gsm) of the above dried fibrous structure are used to calculate the capacity value of ft^2/gsm .

10 Prior to drying the pre-moistened fibrous structure, the surface area of the pre-moistened fibrous structure is measured (ft^2). This surface area of the pre-moistened fibrous structure (ft^2) and the surface area that liquid composition covered (ft^2) is used to calculate the capacity value of ft^2/ft^2 of the pre-moistened fibrous structure.

15 The dimensions and values disclosed herein are not to be understood as being strictly limited to the exact numerical values recited. Instead, unless otherwise specified, each such dimension is intended to mean both the recited value and a functionally equivalent range surrounding that value. For example, a dimension disclosed as “40 mm” is intended to mean “about 40 mm.”

20 Every document cited herein, including any cross referenced or related patent or application and any patent application or patent to which this application claims priority or benefit thereof, is hereby incorporated herein by reference in its entirety unless expressly excluded or otherwise limited. The citation of any document is not an admission that it is prior art with respect to any invention disclosed or claimed herein or that it alone, or in any combination with any other reference or references, teaches, suggests or discloses any such invention. Further, to the extent that any meaning or definition of a term in this document conflicts with any meaning or definition of the same term in a document incorporated by reference, the meaning or definition assigned to that term in this document shall govern.

30 While particular embodiments of the present invention have been illustrated and described, it would be obvious to those skilled in the art that various other changes and modifications can be made without departing from the spirit and scope of the invention. It is therefore intended to cover in the appended claims all such changes and modifications that are within the scope of this invention.

CLAIMS

What is claimed is:

1. A cleaning pad exhibiting a basis weight of at least 100 gsm, wherein the cleaning pad comprises two or more fibrous structure plies comprising pulp fibers, wherein each of the fibrous structure plies exhibits a basis weight of less than 250 gsm and at least one of the fibrous structure plies exhibits a basis weight of greater than 70 gsm to less than 250 gsm, preferably wherein the at least one fibrous structure ply exhibits a basis weight of greater than 75 gsm to less than 250 gsm.
2. The cleaning pad according to Claim 1 wherein at least two of the fibrous structure plies exhibit basis weights of greater than 70 gsm to less than 250 gsm, preferably greater than 75 gsm to less than 250 gsm.
3. The cleaning pad according to Claim 1 or 2 wherein at least three of the fibrous structure plies exhibit basis weights of greater than 70 gsm to less than 250 gsm, preferably greater than 75 gsm to less than 250 gsm.
4. The cleaning pad according to any of the preceding Claims wherein at least one of the fibrous structure plies comprises a core component of the cleaning pad, preferably wherein at least two of the fibrous structure plies comprise one or more core components of the cleaning pad, more preferably wherein at least three of the fibrous structure plies comprise one or more core components of the cleaning pad.
5. The cleaning pad according to any of the preceding Claims wherein the cleaning pad further comprises at least one scrim component, preferably wherein at least one scrim component forms an exterior surface of the cleaning pad and/or wherein at least one scrim component forms an interior surface of the cleaning pad.
6. The cleaning pad according to any of the preceding Claims wherein the cleaning pad comprises a liquid composition, preferably wherein the liquid composition comprises a surfactant and/or wherein the liquid composition comprises a surfactant, an acidifying agent, and an amide and/or wherein the liquid composition comprises an antimicrobial active.
7. The cleaning pad according to Claim 6 wherein the cleaning pad exhibits a mileage value of at least 135 ft²/ fibrous structure as measured according to the Mileage Test Method.

8. The cleaning pad according to Claim 6 or 7 wherein the cleaning pad exhibits a mileage value of at least $0.9 \text{ ft}^2/\text{gsm}$ of the dry cleaning pad as measured according to the Mileage Test Method.
9. The cleaning pad according to any of Claims 6 to 8 wherein the cleaning pad exhibits a mileage value of at least $450 \text{ ft}^2/\text{ft}^2$ of the cleaning pad as measured according to the Mileage Test Method.
10. The cleaning pad according to any of Claims 6 to 9 wherein the cleaning pad exhibits a capacity value of at least 8.5 g of liquid composition/ g of dry cleaning pad as measured according to the Capacity Test Method.
11. The cleaning pad according to any of the preceding Claims wherein the cleaning pad exhibits a basis weight of from 10 to 1000 gsm as measured according to the Fibrous Structure Basis Weight Test Method.
12. A cleaning system comprising an implement and a cleaning pad according to any of the preceding Claims associated with the implement.
13. The cleaning system according to Claim 12 wherein the implement comprises a handle and a cleaning pad holder.
14. Use of a cleaning pad according to any of Claims 1 to 11 to clean a hard surface, preferably a floor.
15. Use of a cleaning system according to Claim 12 or 13 to clean a hard surface, preferably a floor.

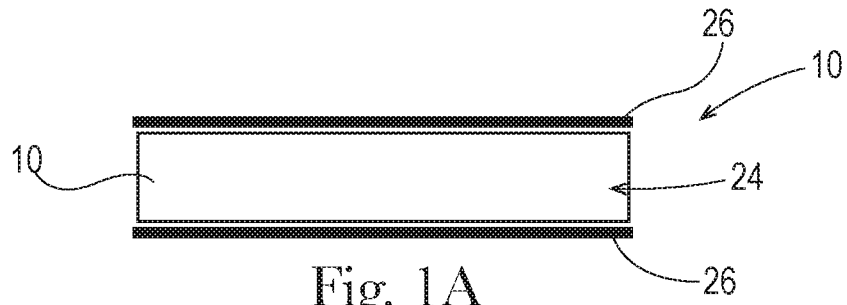

Fig. 1A
PRIOR ART

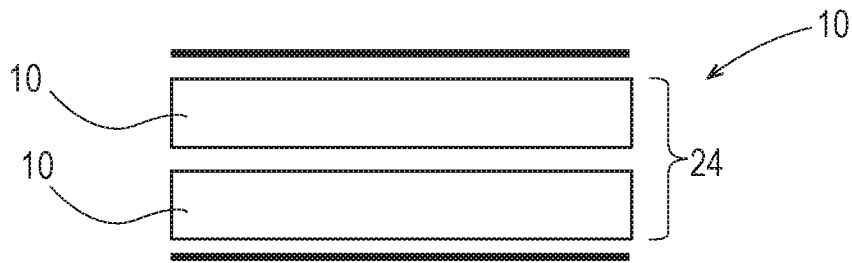

Fig. 2

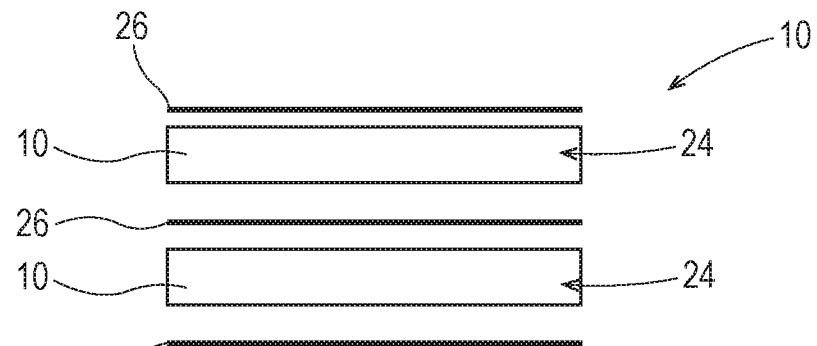

Fig. 3

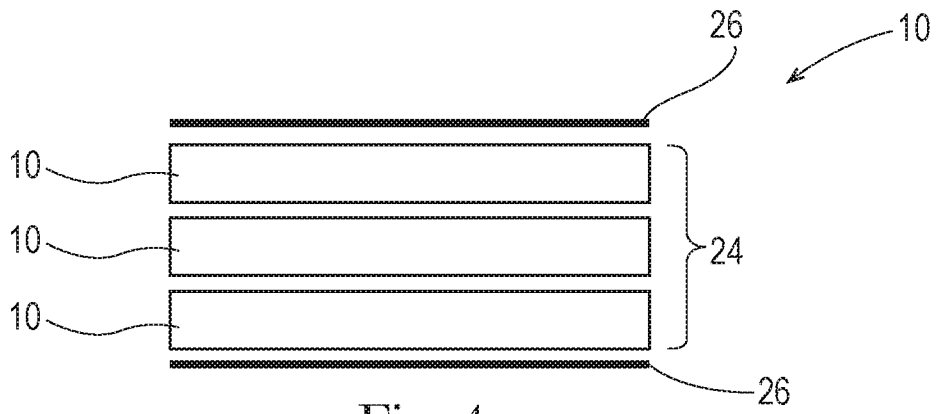

Fig. 4

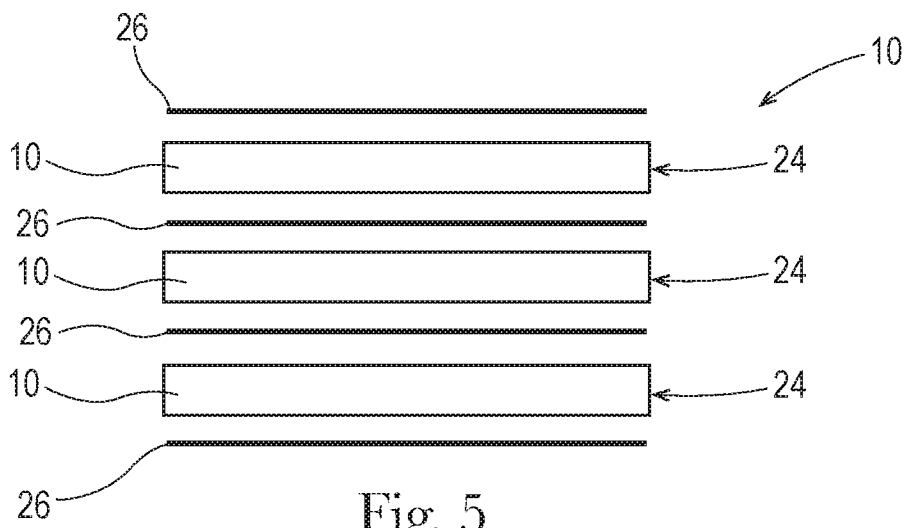

Fig. 5

3/7

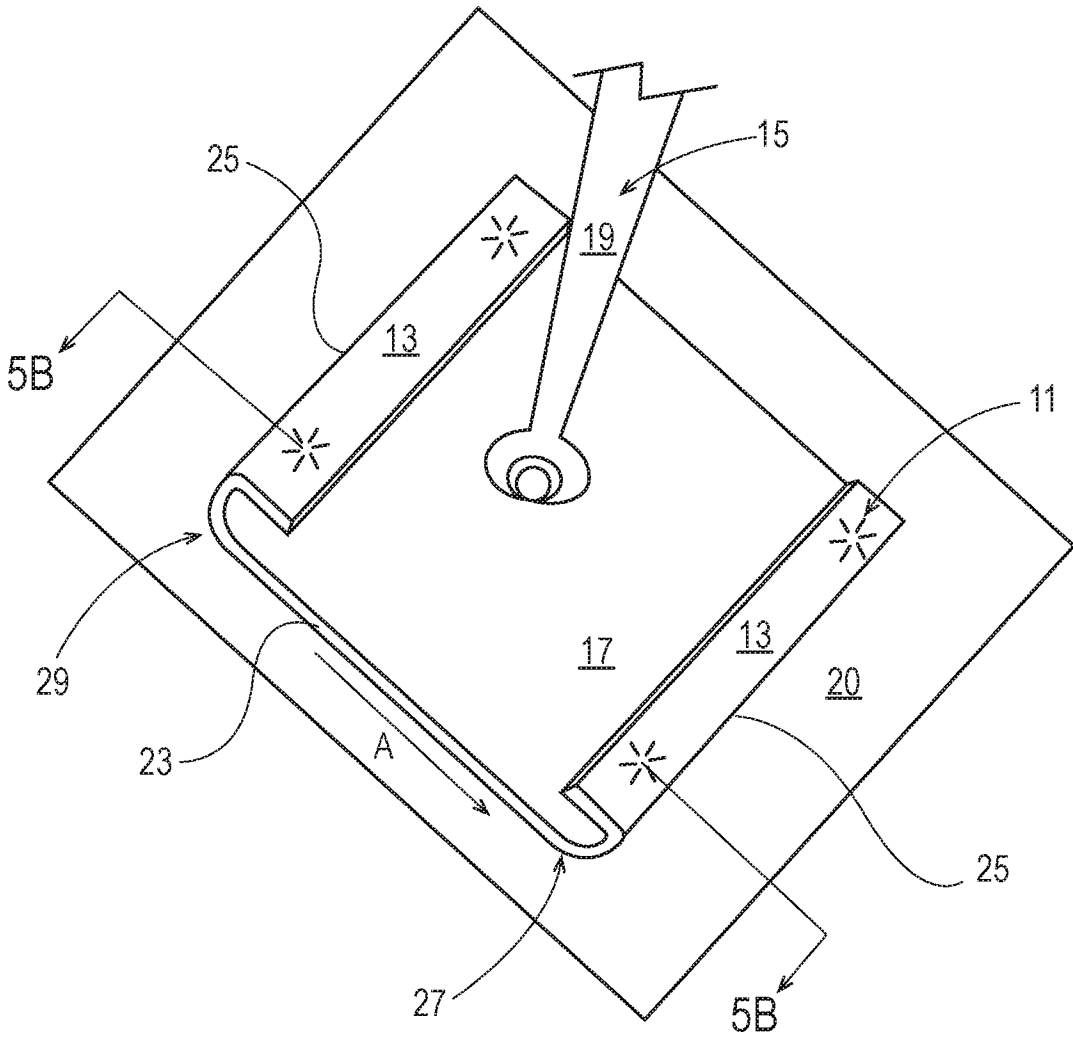

Fig. 6A

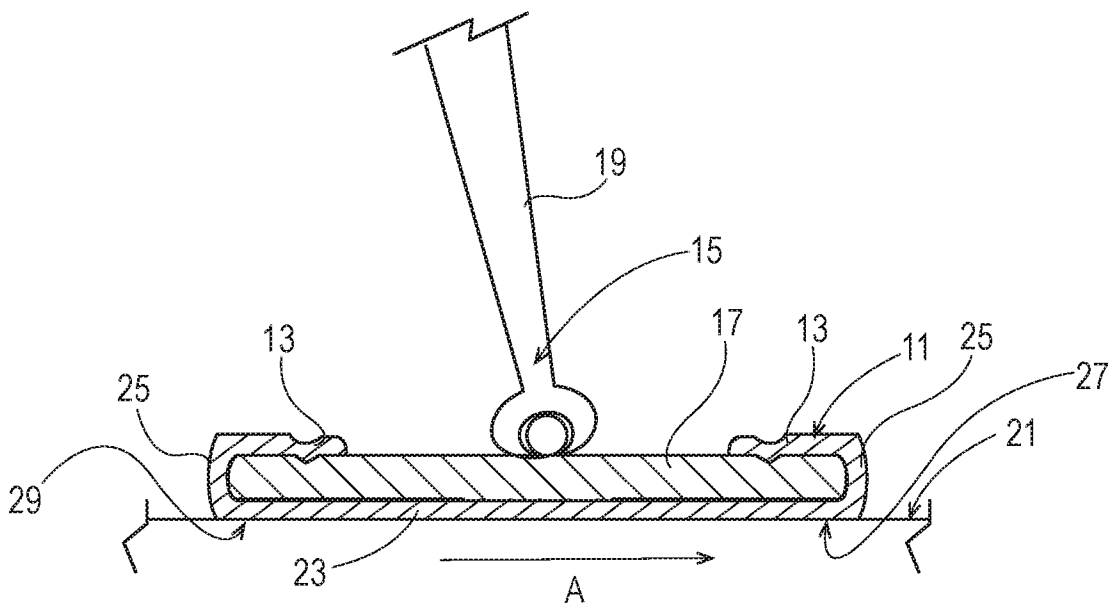

Fig. 6B

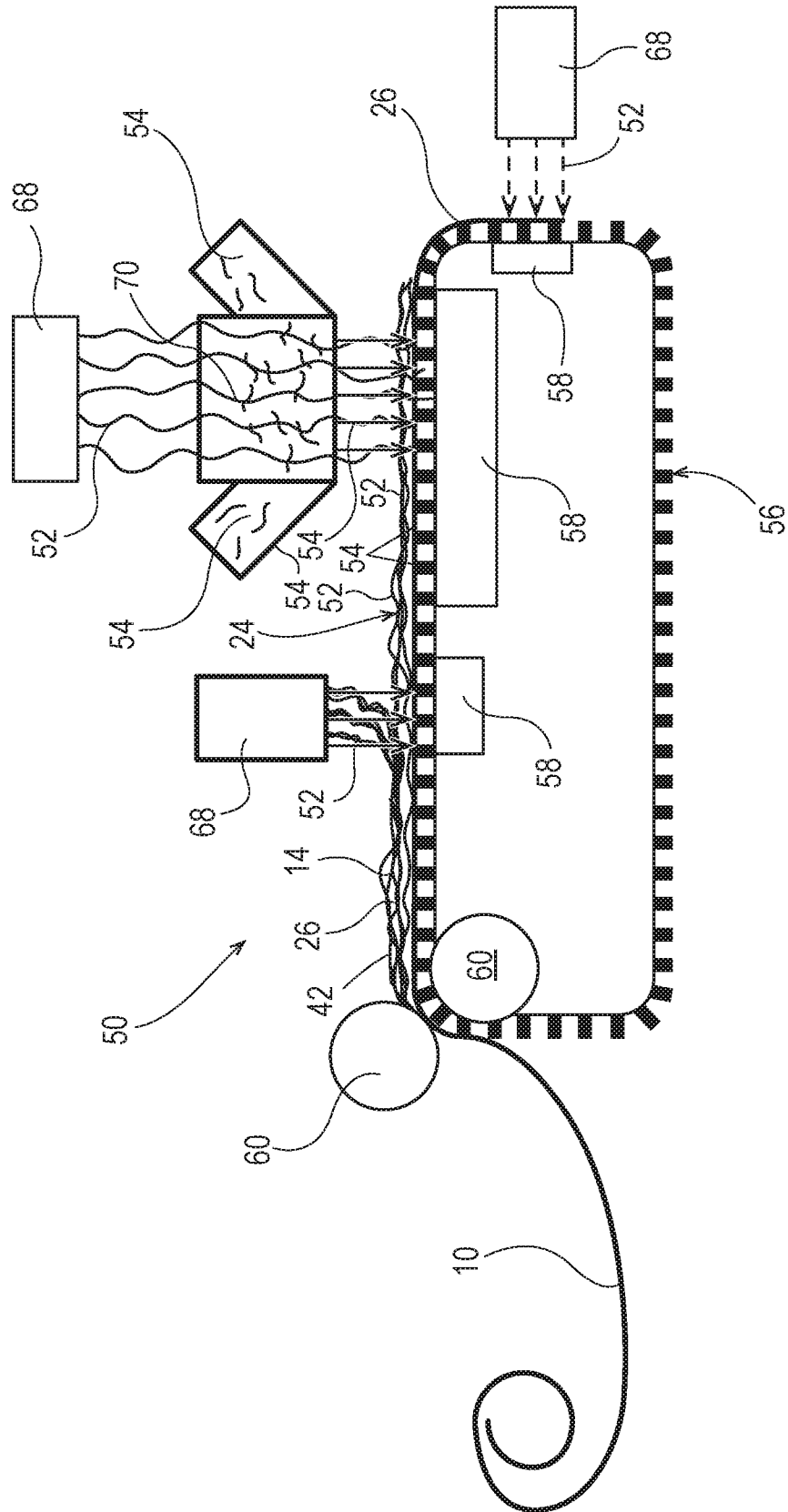

Fig. 7

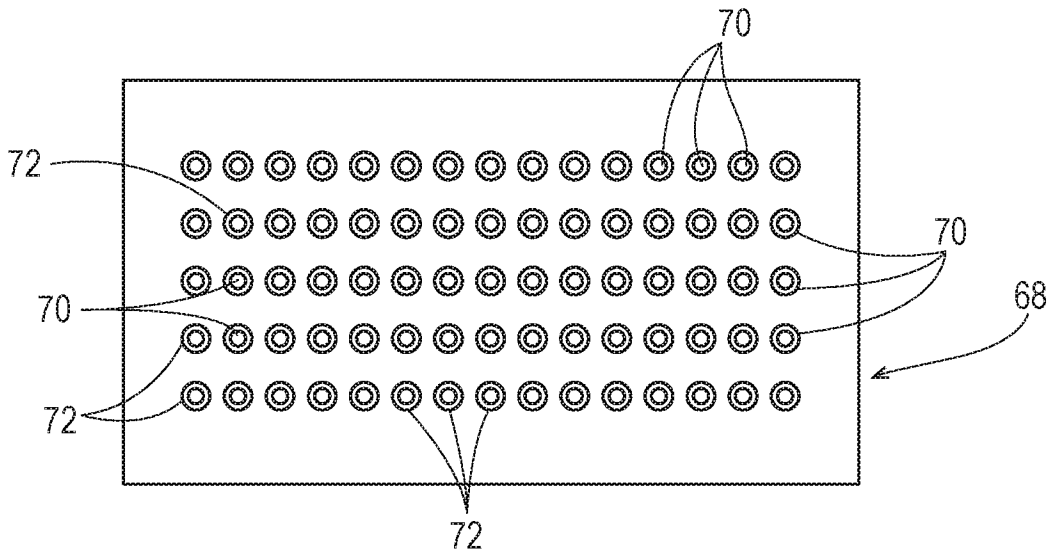

Fig. 8

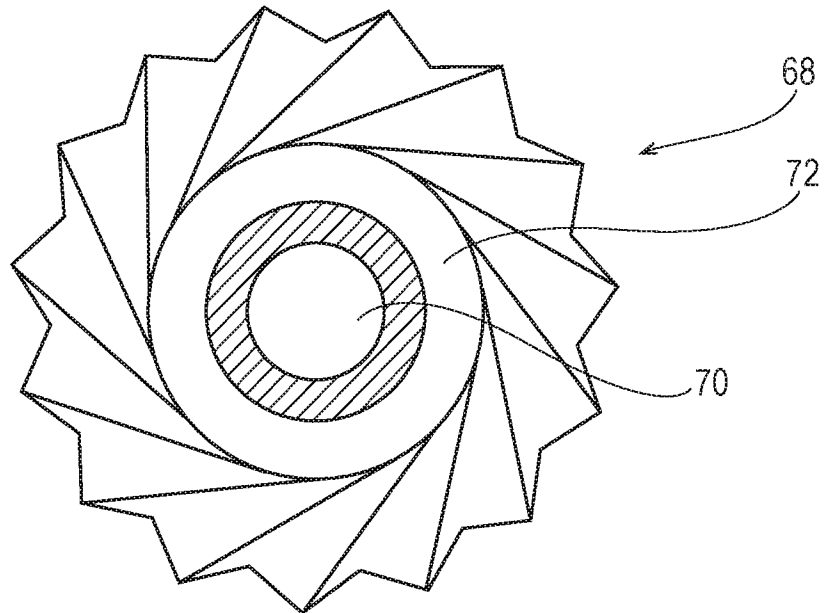

Fig. 9

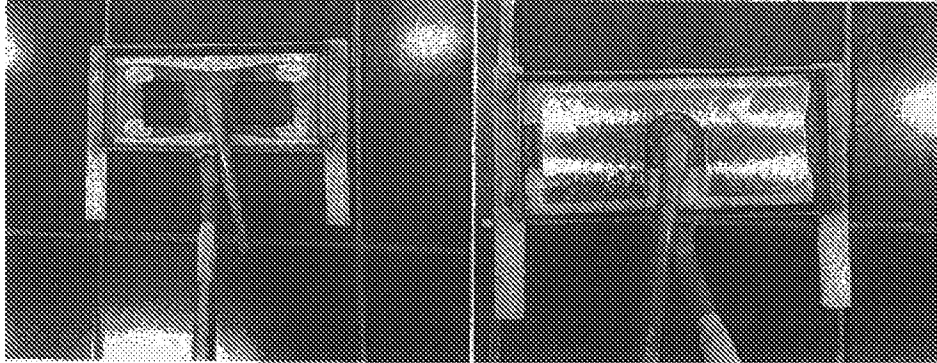

Fig. 10

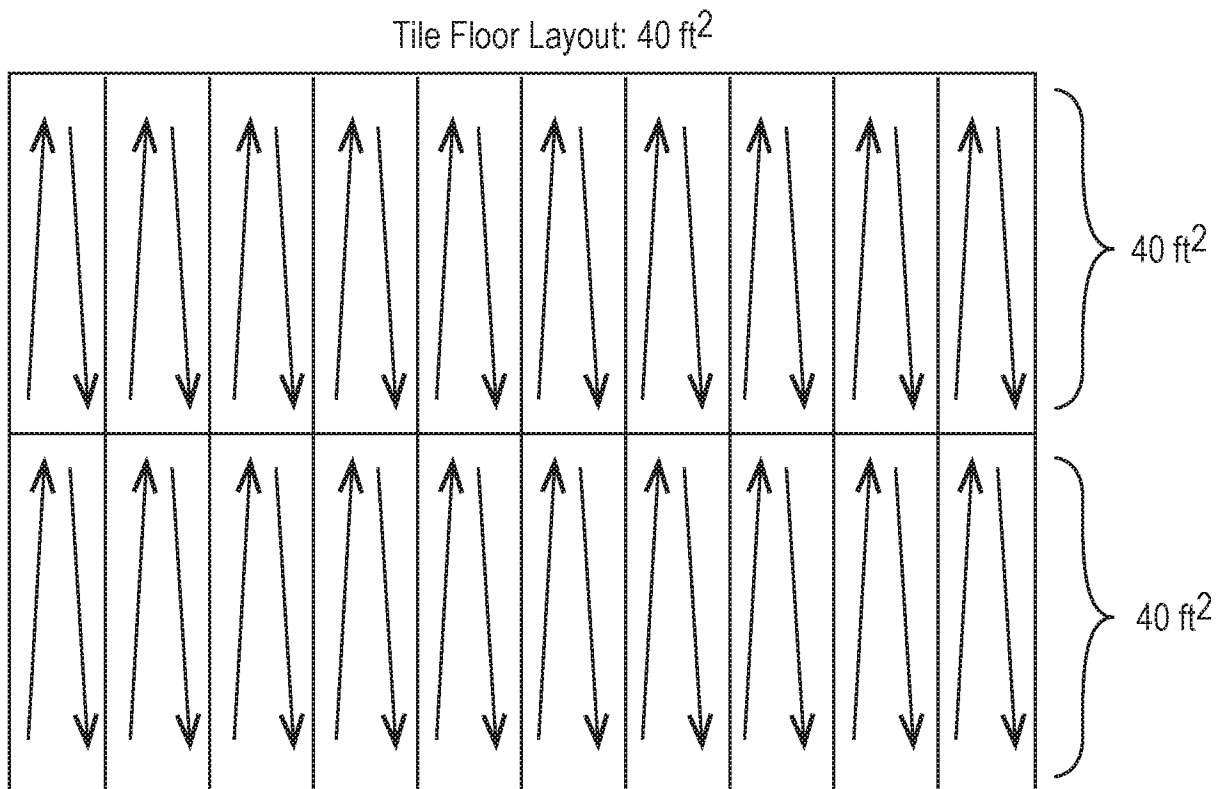
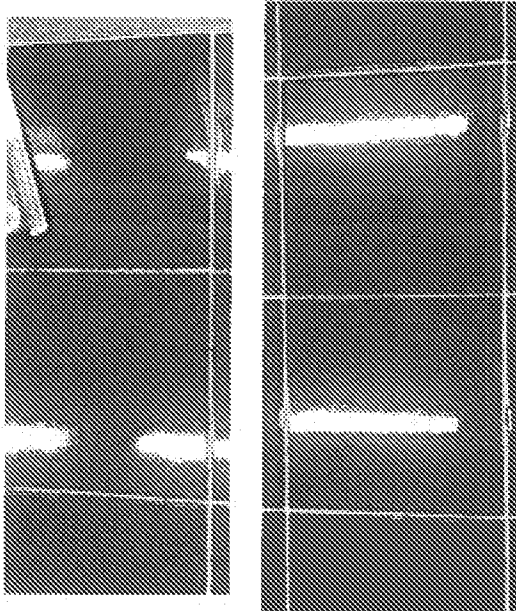
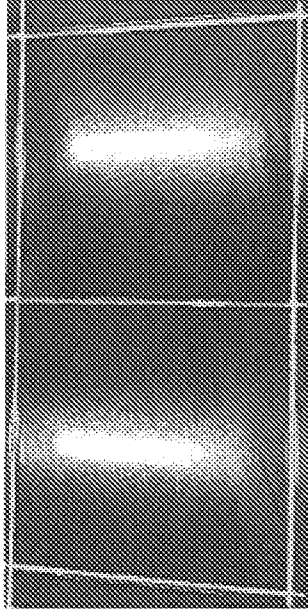

Fig. 11

100% coverage, no streaking



80% coverage, few streaks at the edge



50% coverage, streaks at the edge and the center of the sweep paths;
this is where we record the mileage at the end of the mileage test

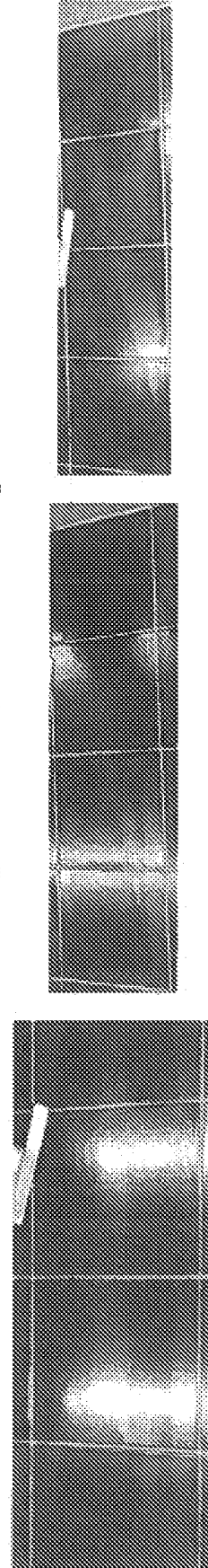

Fig. 12

INTERNATIONAL SEARCH REPORT

International application No PCT/US2017/064998

A. CLASSIFICATION OF SUBJECT MATTER INV. A47L13/17 A47L13/256 ADD.				
According to International Patent Classification (IPC) or to both national classification and IPC				
B. FIELDS SEARCHED				
Minimum documentation searched (classification system followed by classification symbols) A47L				
Documentation searched other than minimum documentation to the extent that such documents are included in the fields searched				
Electronic data base consulted during the international search (name of data base and, where practicable, search terms used) EPO-Internal, WPI Data				
C. DOCUMENTS CONSIDERED TO BE RELEVANT				
Category*	Citation of document, with indication, where appropriate, of the relevant passages	Relevant to claim No.		
X	US 2014/259491 A1 (COLANGELO JOSEPH M [US]) 18 September 2014 (2014-09-18) paragraphs [0031], [0033], [0034], [0050]; claims 1,2,4,7,8,9,10,12,13,15; figures 1,2,7 -----	1-15		
X	EP 3 087 895 A1 (HYDROFLEX OHG [DE]) 2 November 2016 (2016-11-02) paragraph [0025]; claims 1,5,6,9,14,15; figure 2 paragraph [0033] -----	1-15		
X	EP 1 602 310 A2 (UNI CHARM CORP [JP]) 7 December 2005 (2005-12-07) paragraphs [0026], [0047] - [0048]; claims 1,10; figures 1-4 ----- -/--	1-15		
<input checked="" type="checkbox"/> Further documents are listed in the continuation of Box C. <input checked="" type="checkbox"/> See patent family annex.				
* Special categories of cited documents : <table style="width: 100%; border: none;"> <tr> <td style="width: 50%; border: none; vertical-align: top;"> "A" document defining the general state of the art which is not considered to be of particular relevance "E" earlier application or patent but published on or after the international filing date "L" document which may throw doubts on priority claim(s) or which is cited to establish the publication date of another citation or other special reason (as specified) "O" document referring to an oral disclosure, use, exhibition or other means "P" document published prior to the international filing date but later than the priority date claimed </td> <td style="width: 50%; border: none; vertical-align: top;"> "T" later document published after the international filing date or priority date and not in conflict with the application but cited to understand the principle or theory underlying the invention "X" document of particular relevance; the claimed invention cannot be considered novel or cannot be considered to involve an inventive step when the document is taken alone "Y" document of particular relevance; the claimed invention cannot be considered to involve an inventive step when the document is combined with one or more other such documents, such combination being obvious to a person skilled in the art "&" document member of the same patent family </td> </tr> </table>			"A" document defining the general state of the art which is not considered to be of particular relevance "E" earlier application or patent but published on or after the international filing date "L" document which may throw doubts on priority claim(s) or which is cited to establish the publication date of another citation or other special reason (as specified) "O" document referring to an oral disclosure, use, exhibition or other means "P" document published prior to the international filing date but later than the priority date claimed	"T" later document published after the international filing date or priority date and not in conflict with the application but cited to understand the principle or theory underlying the invention "X" document of particular relevance; the claimed invention cannot be considered novel or cannot be considered to involve an inventive step when the document is taken alone "Y" document of particular relevance; the claimed invention cannot be considered to involve an inventive step when the document is combined with one or more other such documents, such combination being obvious to a person skilled in the art "&" document member of the same patent family
"A" document defining the general state of the art which is not considered to be of particular relevance "E" earlier application or patent but published on or after the international filing date "L" document which may throw doubts on priority claim(s) or which is cited to establish the publication date of another citation or other special reason (as specified) "O" document referring to an oral disclosure, use, exhibition or other means "P" document published prior to the international filing date but later than the priority date claimed	"T" later document published after the international filing date or priority date and not in conflict with the application but cited to understand the principle or theory underlying the invention "X" document of particular relevance; the claimed invention cannot be considered novel or cannot be considered to involve an inventive step when the document is taken alone "Y" document of particular relevance; the claimed invention cannot be considered to involve an inventive step when the document is combined with one or more other such documents, such combination being obvious to a person skilled in the art "&" document member of the same patent family			
Date of the actual completion of the international search		Date of mailing of the international search report		
19 March 2018		27/03/2018		
Name and mailing address of the ISA/ European Patent Office, P.B. 5818 Patentlaan 2 NL - 2280 HV Rijswijk Tel. (+31-70) 340-2040, Fax: (+31-70) 340-3016		Authorized officer Finzel, Jana		

INTERNATIONAL SEARCH REPORT

International application No PCT/US2017/064998

C(Continuation). DOCUMENTS CONSIDERED TO BE RELEVANT

Category*	Citation of document, with indication, where appropriate, of the relevant passages	Relevant to claim No.
X	US 2004/144406 A1 (GARABEDIAN ARAM [US] ET AL) 29 July 2004 (2004-07-29) paragraph [0232]; claims 1,2,8,9,34; table 7	1-15
X	----- EP 0 492 554 A1 (KIMBERLY CLARK CO [US]) 1 July 1992 (1992-07-01) claims 1,6,15,17; figures 1,7; examples 1,2 -----	1-4, 11-15

INTERNATIONAL SEARCH REPORT

Information on patent family members

International application No PCT/US2017/064998

Patent document cited in search report	Publication date	Patent family member(s)	Publication date
US 2014259491	A1	18-09-2014	NONE
EP 3087895	A1	02-11-2016	NONE
EP 1602310	A2	07-12-2005	CN 1704014 A 07-12-2005
			EP 1602310 A2 07-12-2005
			JP 4116590 B2 09-07-2008
			JP 2005342257 A 15-12-2005
			KR 20060049479 A 19-05-2006
			TW 1299258 B 01-08-2008
			US 2005268419 A1 08-12-2005
US 2004144406	A1	29-07-2004	US 2004144406 A1 29-07-2004
			WO 2005072119 A2 11-08-2005
EP 0492554	A1	01-07-1992	AU 649284 B2 19-05-1994
			BR 9105555 A 01-09-1992
			CA 2048905 A1 22-06-1992
			DE 69115002 D1 11-01-1996
			DE 69115002 T2 27-06-1996
			EP 0492554 A1 01-07-1992
			ES 2082105 T3 16-03-1996
			JP 2533260 B2 11-09-1996
			JP H05179545 A 20-07-1993
			US 5284703 A 08-02-1994
			US 5389202 A 14-02-1995
			ZA 9109343 B 30-09-1992