

# La Bamster & Doggett. Spinning Throstle.

N<sup>o</sup>: 105,815.

Patented Jul. 26, 1870.

Fig. 1.

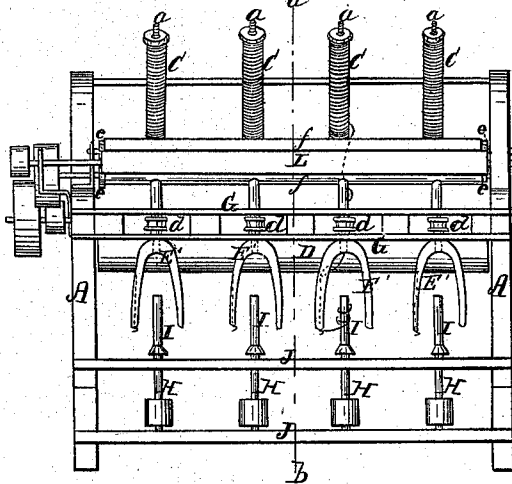

Fig. 3.

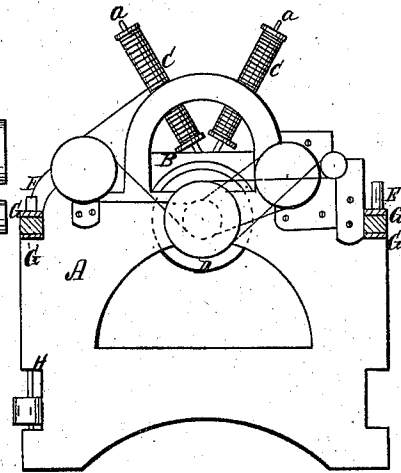

Fig. 2.

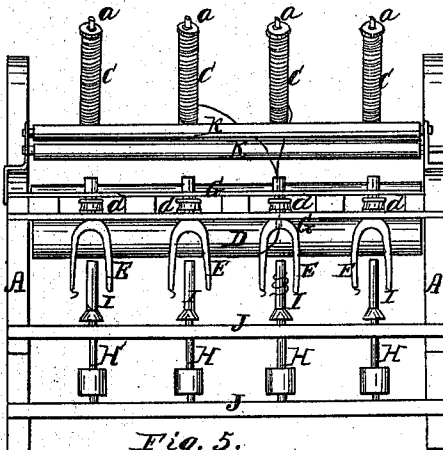

Fig. 4.

Section through a-b.

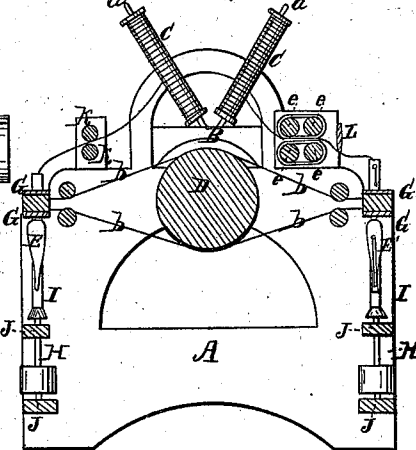
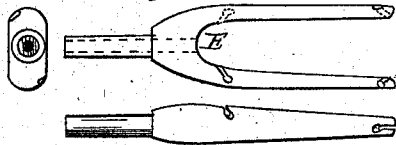

Fig. 5.



Witnesses

*Ed. Gentry*  
*Wm. H. Harris*

Inventor

*William La Bamster*  
*Lorenzo V. Doggett*  
*Alexander Duasore*  
*Atty.*

# United States Patent Office.

WILLIAM LA BANISTER AND LORENZO V. DAGGETT, OF PACIFIC, WISCONSIN.

Letters Patent No. 105,815, dated July 26, 1870.

## IMPROVEMENT IN SPINNING-MACHINES.

The Schedule referred to in these Letters Patent and making part of the same

To all whom it may concern:

Be it known that we, WILLIAM LA BANISTER and LORENZO V. DAGGETT, of Pacific, in the county of Columbia and in the State of Wisconsin, have invented certain new and useful Improvements in Spinning-Machine; and do hereby declare that the following is a full, clear, and exact description thereof, reference being had to the accompanying drawing and to the letters of reference marked thereon making a part of this specification.

The nature of our invention consists in the construction and arrangement of a "machine for spinning both wool and cotton," one side of the machine being arranged for spinning wool and the other for cotton.

In order to enable others skilled in the art to which our invention appertains to make and use the same, we will now proceed to describe its construction and operation, referring to the annexed drawing, in which—

Figure 1 is a view of the side of our machine arranged for spinning wool;

Figure 2 is a view of the other side, arranged for spinning cotton;

Figure 3 is an end view; and

Figure 4 is a transverse vertical section of our machine.

Figure 5 shows enlarged views of the flyer.

A represents the frame of our machine, made of any suitable material, and of any desired dimensions.

Along the center of the frame A, in the upper part, is a bar, B, upon which are two rows of pins or posts, *a a*.

These pins or posts are inclined, one row toward one side and the other row toward the other side, said pins or posts having the spools *c c* placed upon them.

Under the bar B is a large cylinder, D, placed upon a shaft which has its bearings in the end pieces of the frame A, and is turned by any suitable means.

Around this cylinder is a number of belts, *b b*, which pass around pulleys, *d d*, attached on the shanks of the flyers E E.

These flyers, the construction of which will be hereinafter set forth, are arranged on each side of the frame, as shown in the drawing, their pulleys being between the bars G G.

Under each flyer is placed a bobbin, I, upon a weighted spindle, H, which is supported in the rails J J.

The rails J J are to be made movable, the same as on most spinning-machines now in use, so that the weighted spindles can be raised and lowered to wind the bobbin evenly.

On the side of the machine adapted for spinning

cotton are two rollers, K K, between which the threads pass from the bobbin O to the flyers, said rollers being operated by belts from the shaft of the cylinder D.

Behind these rollers should also be placed two sets of fluted rollers, which I have not deemed it necessary to represent, as they are in common use on most spinning-machines.

On the wool-spinning side of the machine are two pairs of rollers, *e e*, each pair being surrounded by an endless apron, *f*, and between said aprons the woolen strands from the spool are passed.

The object of this is to keep the wool together as much as possible without breaking, which it is very liable to do when passing between smooth or fluted rollers, as is now generally the case.

The aprons are made to revolve by belts connecting pulleys on the rollers *e e* with pulleys on the shaft of the cylinder D.

When the strands pass out from between the aprons *f f*, they pass under the elongated beater L, which consists of a flat bar, of any suitable dimensions, having journals upon its ends, upon which it revolves, it being operated in the same manner as the rollers *e e*, above described.

The object of this elongated beater is to draw the strands. As the strand is too large to make a thread, it wants drawing out while it is spinning, and it wants and has to be drawn where it is twisting. Now, the beater strikes the strands as fast as they come from between the aprons, and pulls them a little at every revolution, allowing the twist to pass by full to the apron. Thus the roving is drawn out very evenly.

The wool-spinning flyer E' is constructed as shown in fig. 1, the yarn entering in a hole in the center of the shank or neck, and running slanting out through the side, then again entering the neck, passing through the neck and the guide-eye on the side, then passing to the guide-eye at the lower end, and thence to the bobbin.

These flyers may be cast of any metal, or forged, and may be provided, at the ends, with a ring, to keep the arms from spreading when speeded too high. The guides on the twisters may be either wire hooks attached to them, or inclined slots cut in them.

The cotton-spinning flyers E are made of forged or cast malleable iron, or any suitable metal, with the hole running through the center of the neck, and having two guides for the thread, as shown in fig. 5.

There being two bearings to each flyer, one on each side of the pulley, there is no shake to them, and being each of one solid piece, they are capable of rotation at a very high speed.

Having thus fully described our invention,

What we claim as new, and desire to secure by Letters Patent, is—

1. The combination of two or more sets of rollers *e e*, each set being covered or inclosed by an endless apron, and the elongated beater *L*, all constructed and arranged to operate substantially as and for the purposes herein set forth.

2. The arrangement of the frame *A*, bar *B*, inclined posts *a a*, cylinder *D*, rollers *e e*, aprons *f f*, beater *L*, flyers *E*, spindles *H*, and bobbins *I*, all sub-

stantially as shown and described, and for the purposes set forth.

In testimony that we claim the foregoing, we have hereunto set our hands and seals this 14th day of April, 1870.

WILLIAM LA BANISTER. [L. s.]

LORENZO V. DAGGETT. [L. s.]

Witnesses:

Z. J. D. SWIFT,

LYDIA A. SWIFT.