



US 20060180030A1

(19) **United States**

(12) **Patent Application Publication**

Bates et al.

(10) **Pub. No.: US 2006/0180030 A1**

(43) **Pub. Date: Aug. 17, 2006**

(54) **HOT BEVERAGE MAKER BREW BASKET ADAPTOR**

Related U.S. Application Data

(63) Continuation-in-part of application No. 11/059,886, filed on Feb. 17, 2005.

(76) Inventors: **Roy Bates**, Glen Allen, VA (US); **Steve Williamson**, Arvonnia, VA (US); **William D. Starr**, Richmond, VA (US)

Publication Classification

(51) **Int. Cl.**
A47G 19/14 (2006.01)
(52) **U.S. Cl.** **99/323**

Correspondence Address:
John H. Thomas, P.C.
536 Granite Avenue
Richmond, VA 23226 (US)

(57) **ABSTRACT**

A brew basket for a hot beverage maker has a funnel-shape with a relatively wide top end and relatively narrow bottom end. A stepped support ring is integral in and defines a ledge around a circumference of the brew basket. A filter pod is supported on its periphery by the support ring during brewing. An adaptor can be integrally attached to the brew basket to give a user an option to place a second filter pod in the brew basket to yield more or stronger brewed beverage.

(21) Appl. No.: **11/211,264**

(22) Filed: **Aug. 25, 2005**

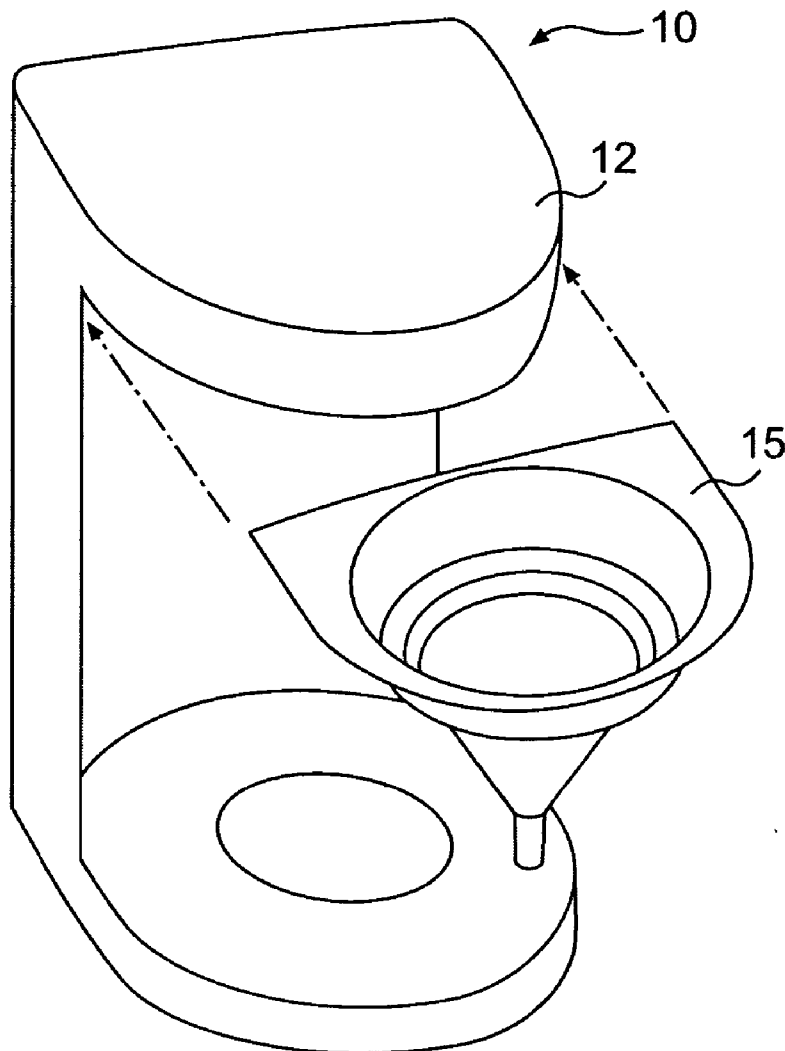

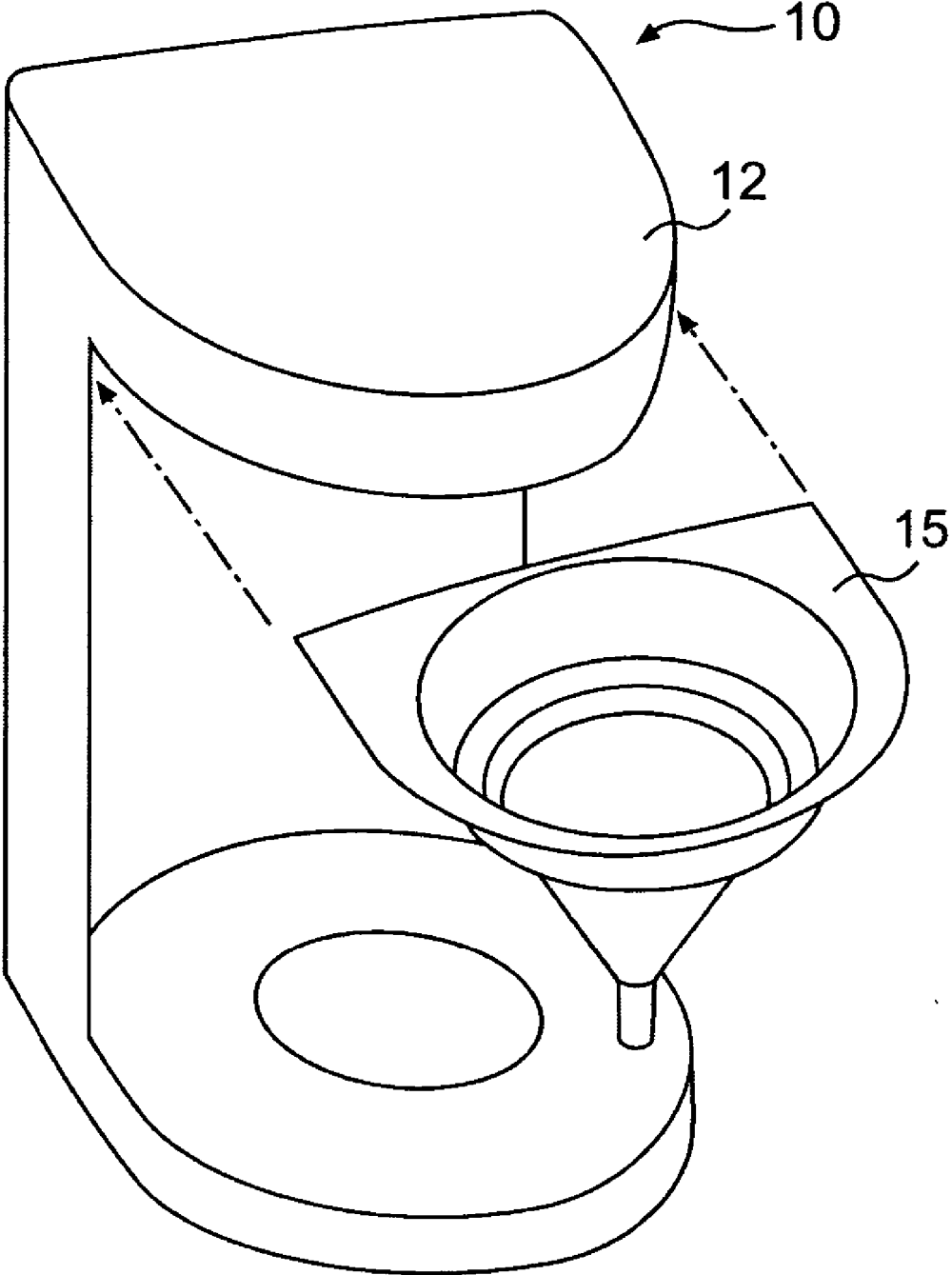

FIG. 1

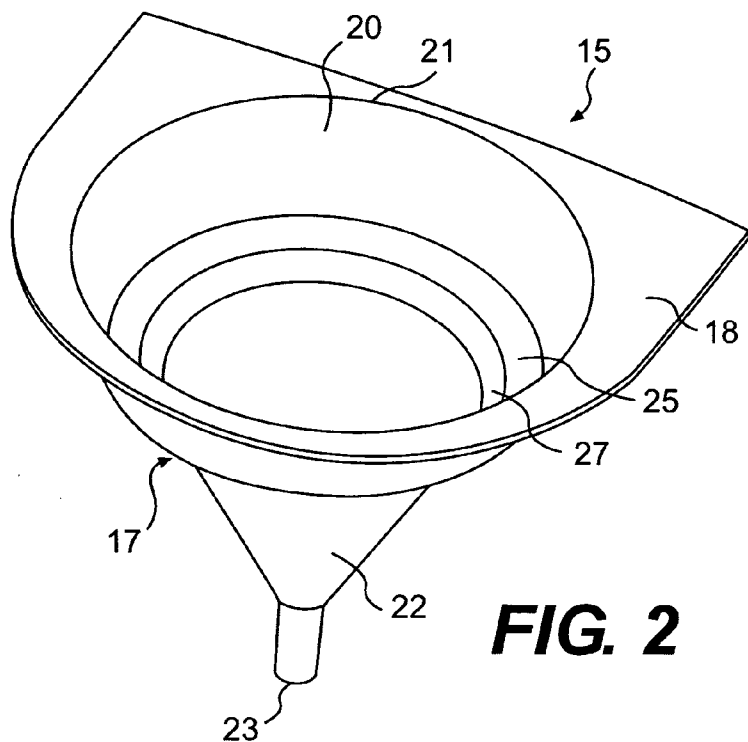

FIG. 2

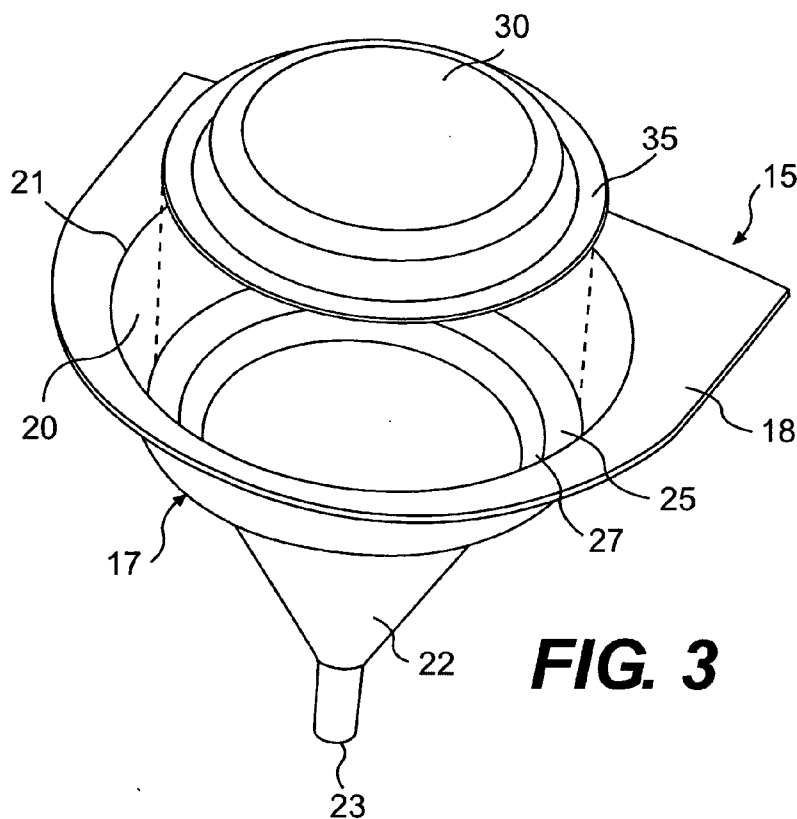

FIG. 3

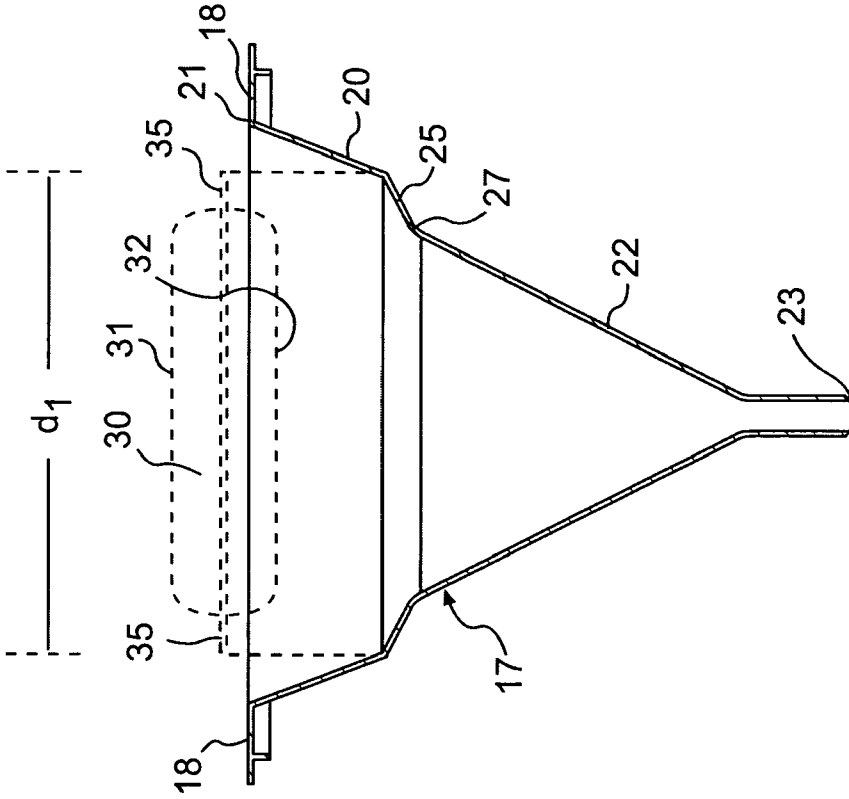

FIG. 5

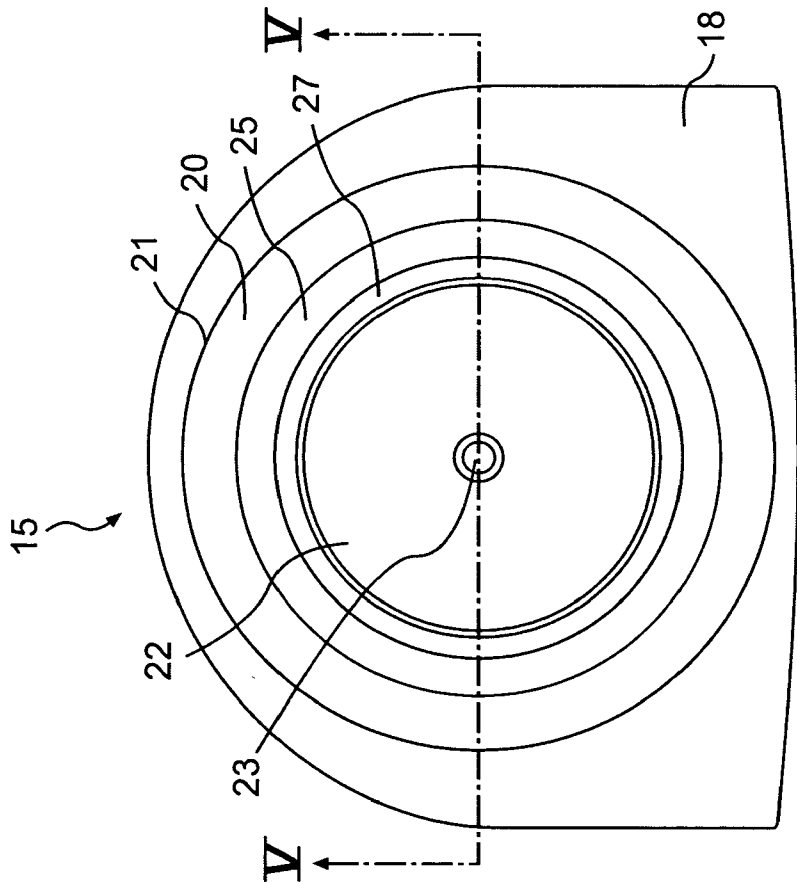

FIG. 4

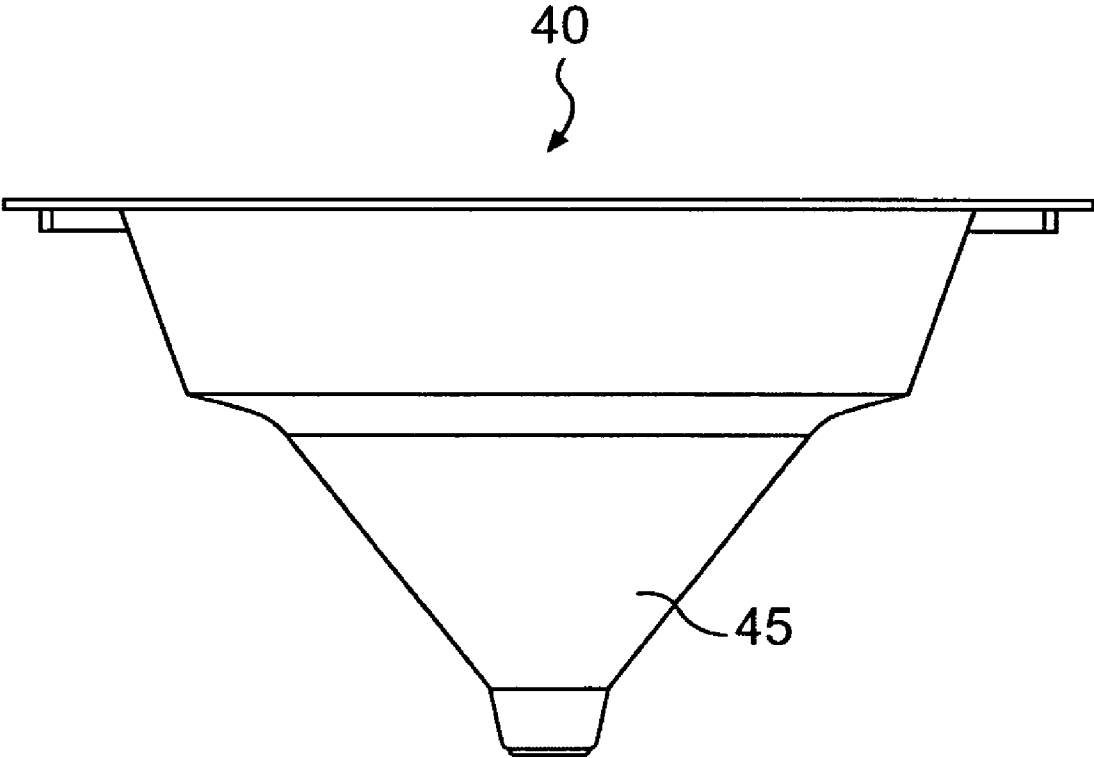

FIG. 6

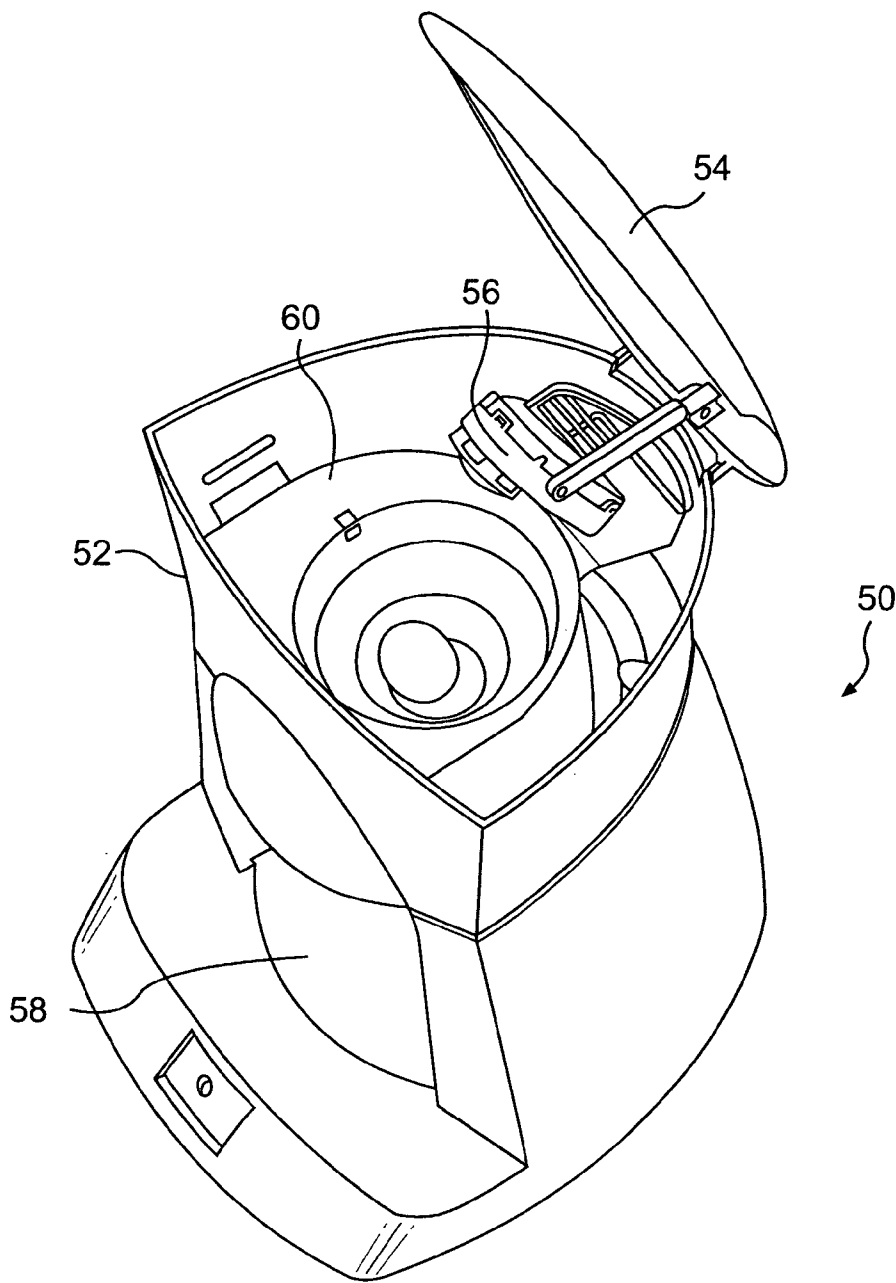

FIG. 7

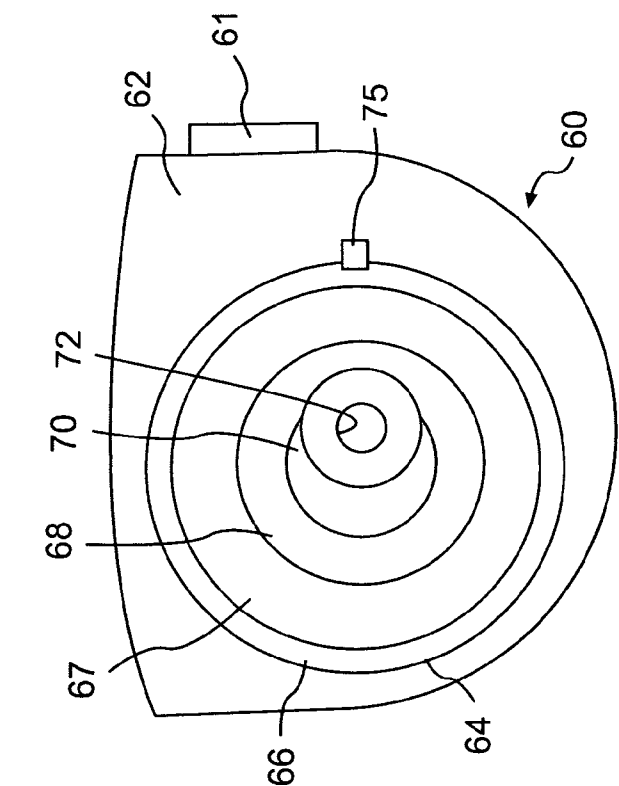

FIG. 8

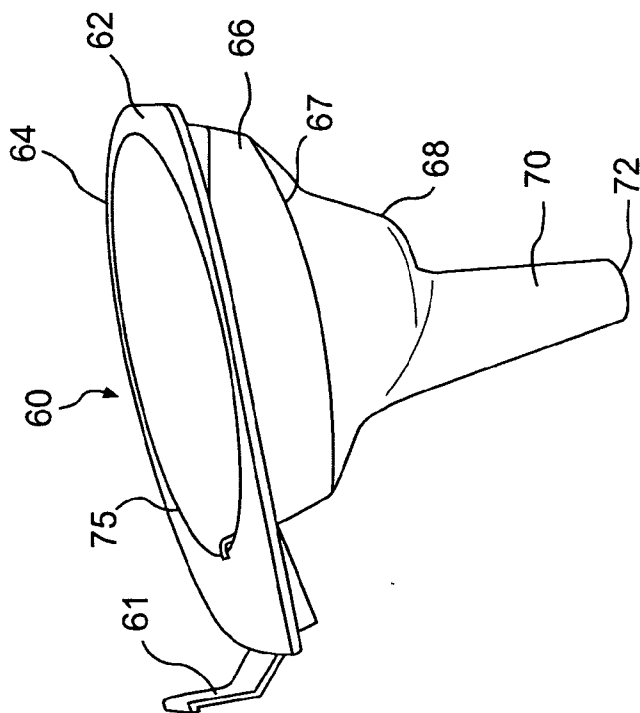

FIG. 9

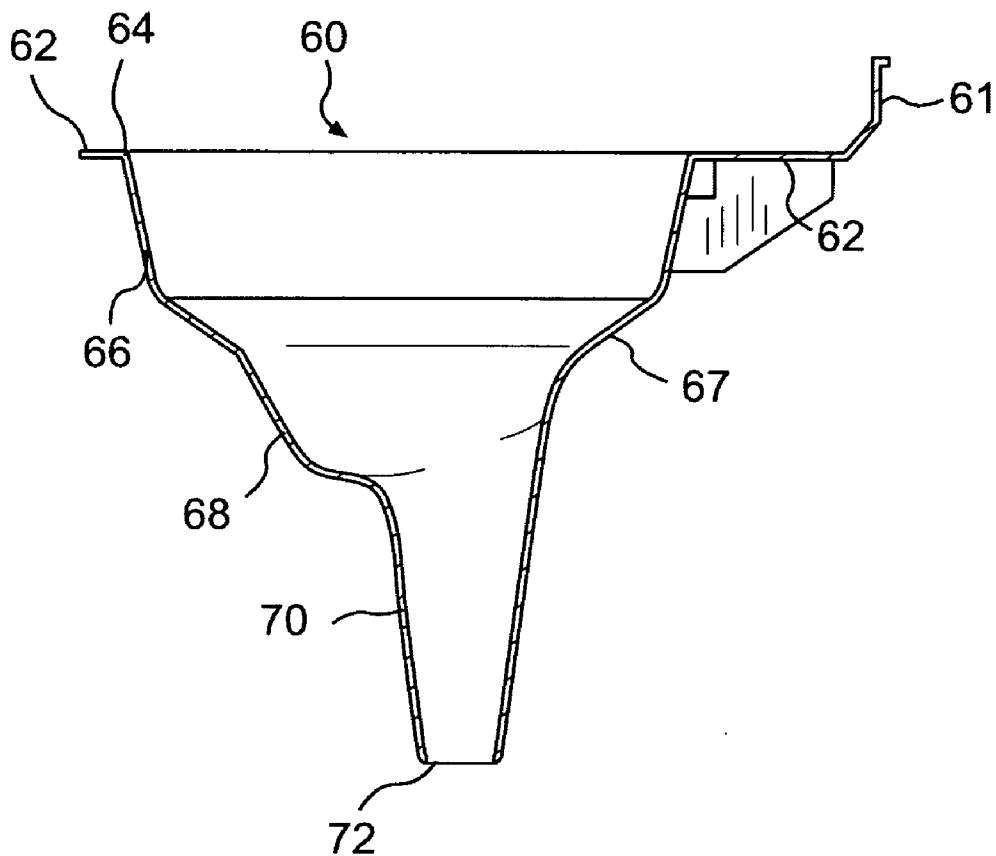

FIG. 10

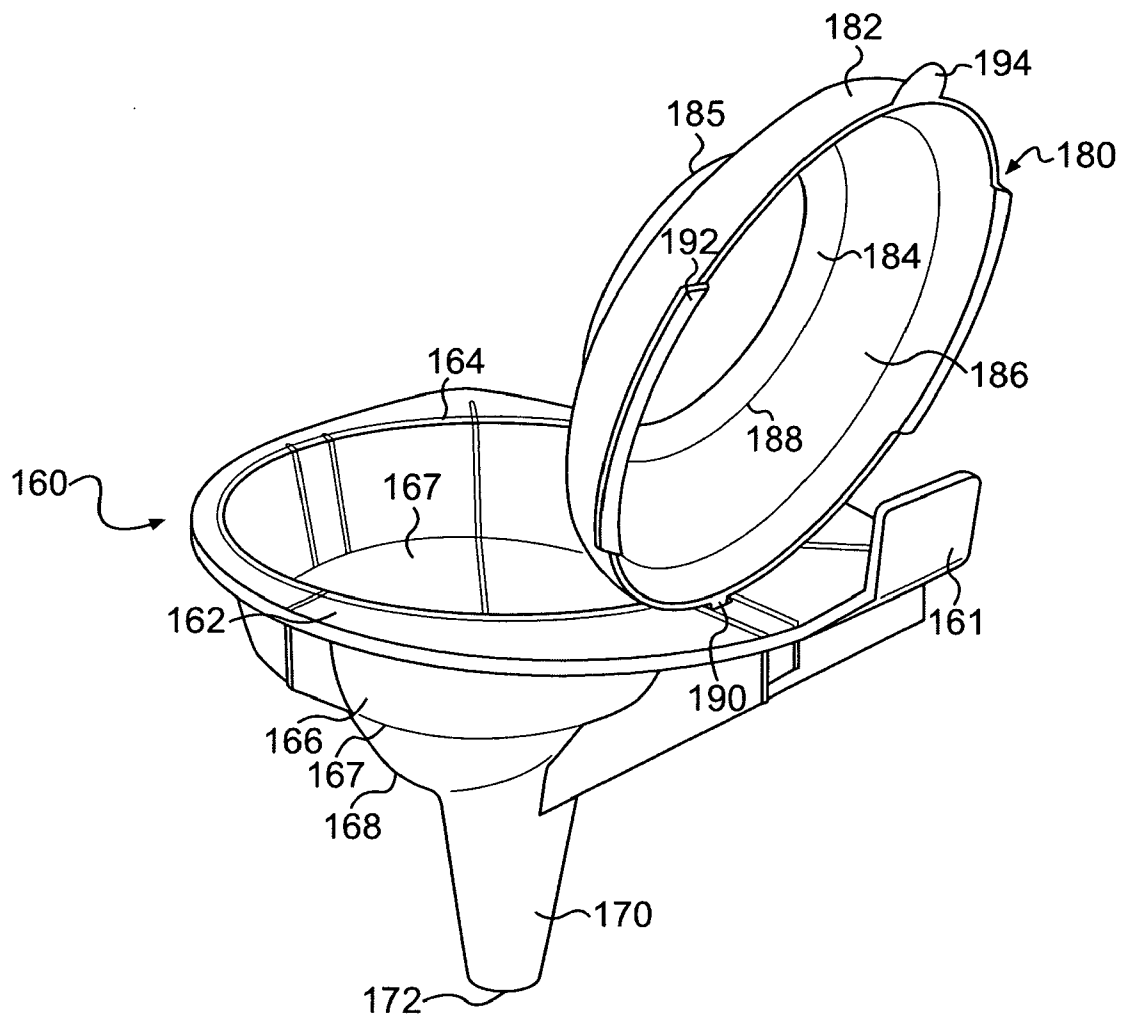

FIG. 11

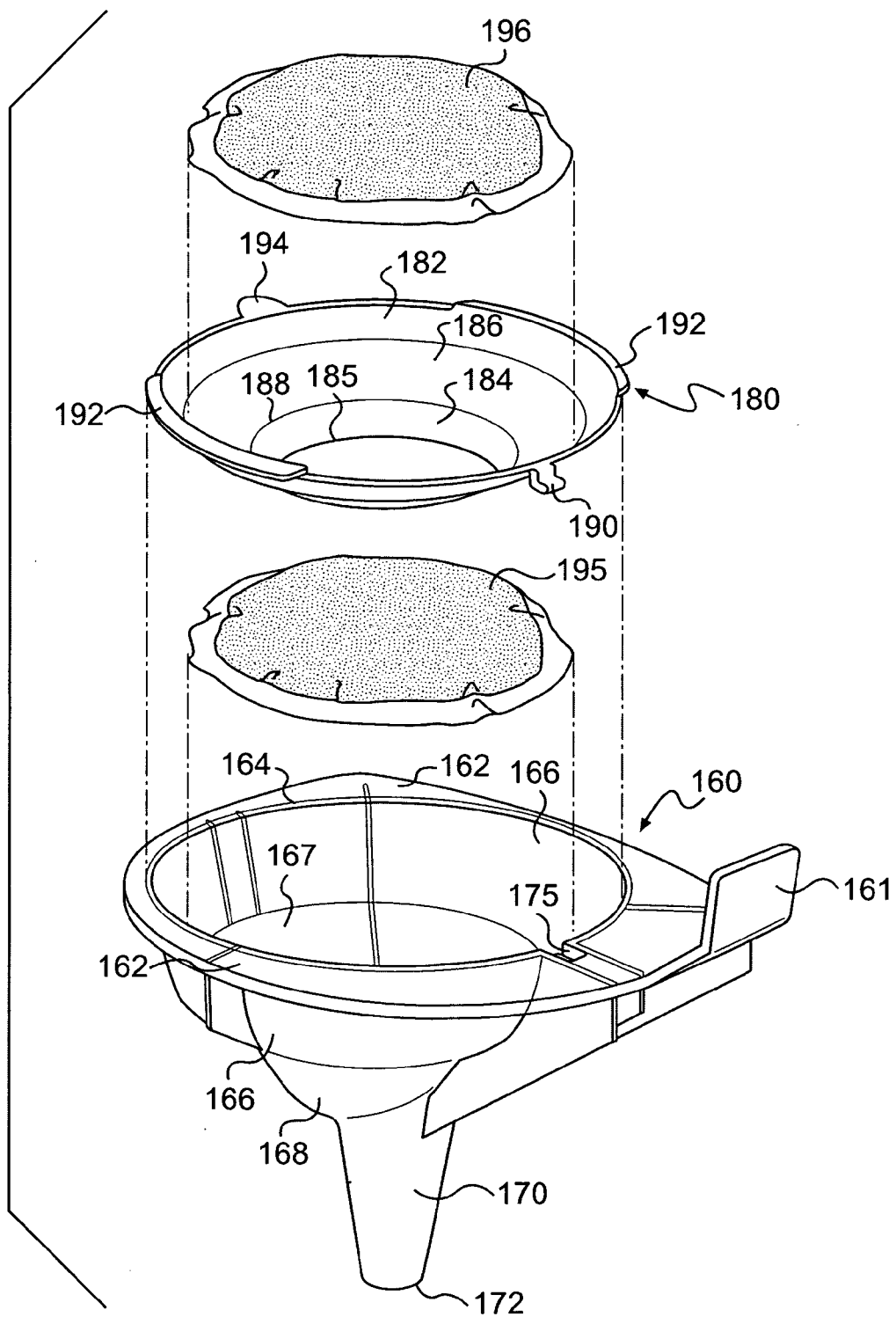

FIG. 12

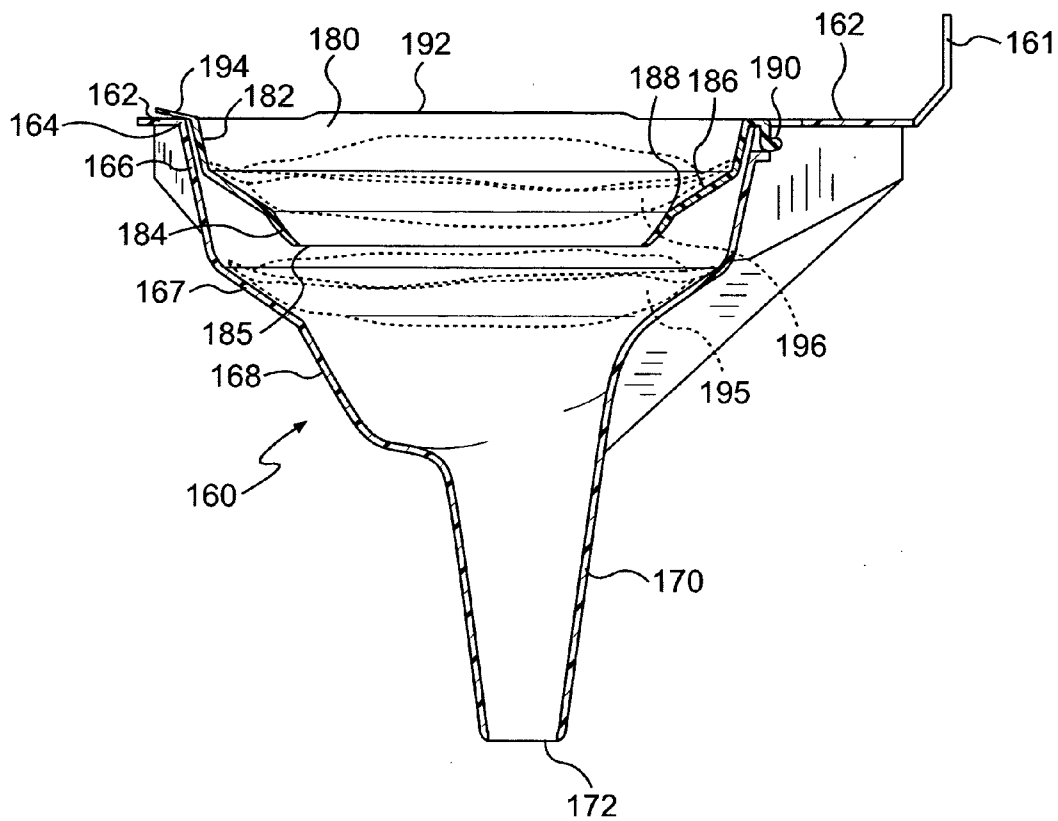

FIG. 13

HOT BEVERAGE MAKER BREW BASKET ADAPTOR

[0001] This application is a continuation-in-part application of U.S. application Ser. No. 11/059,886 filed Feb. 17, 2005.

[0002] The present invention relates to a brew basket adaptor for a hot beverage maker. Specifically, a brew basket is shaped to be used with a soft pack filter pod of coffee or other brewing material. An adaptor can be integrally attached to the brew basket to give a user an option to place a second filter pod in the brew basket to yield a greater volume of, or stronger flavor for, a brewed beverage.

BACKGROUND OF THE INVENTION

[0003] Hot beverage makers and especially automatic drip coffee makers are well known and widely used. They are effective to brew carafes of coffee, typically containing five to eight cups or more of liquid. Automatic drip coffee makers may also be used for brewing small batches (one to four cups), and some coffee makers include known modifications and adjustments to hot water flow rates to improve the quality of the brewed beverage in small batches.

[0004] An alternative to using loose coffee grinds placed in a filter is to simply place prepackaged filter packs into a brew basket. Prepackaged filter packs contain a predetermined amount of coffee grinds adapted to brew approximately four to six cups per pack. More than one filter pack may be used at a time depending on the quantity of coffee being brewed or on the specific taste of the consumer.

[0005] A recent coffee maker platform that has been developed uses single serving filter pods in a pressurized, hot water system. While these filter pods work well to brew coffee in these pressurized systems, there are challenges in the use of filter pods with an automatic drip coffee maker platform. For instance, a filter pod may float in water inside a brew basket or become tilted in a brew basket. The result is weak and inconsistent coffee, because water is able to go by and not through the filter pod containing the coffee grinds. Conventional automatic drip coffee maker brew baskets are not engineered to effectively accommodate filter pods.

[0006] Another potential limitation with the use of a single filter pod in a hot beverage brewing platform is that there is an invariable amount of flavor and solids that may be extracted from the pod, thereby limiting either the volume of hot beverage produced or its strength. There is a need to be able to use two or more hot beverage filter pods to brew stronger or larger serving size brewed beverages. Unfortunately, there are problems in the use of two or more hot beverage pods in traditional hot beverage makers. Using multiple filter pods in traditional brew baskets allows the pods to float, have an inconsistent "dwell time" with the hot water, and/or become disoriented in the fluid flow, thereby affecting the brewing mechanics and causing the brewed beverage to have an unpredictable strength.

SUMMARY OF THE INVENTION

[0007] Accordingly, it is an object of the present invention to overcome the difficulties in the use of one or more filter pods with a hot beverage maker system. Briefly, the improved brew basket is specially engineered to support one

or more filter pods during the brewing process to improve extraction and repeatability of the process.

[0008] In one example, an automatic drip coffee maker brew basket comprises a hollow, funnel-shaped brew basket having a relatively wide top end and a relatively narrow bottom end. Both the top and bottom ends are open to allow the flow of liquid through the basket. A stepped support ring is integral in and defines a ledge around a circumference of the brew basket, wherein the circumference is below the top end and above the bottom end. A coffee filter pod is then able to be supported on its periphery by the support ring during brewing.

[0009] In another example, an automatic drip coffee maker comprises a pod and a funnel-shaped brew basket. The pod comprises an amount of coffee material packaged within at least first and second sheets of filter web material. The sheets of filter web material are fixed to each other about their periphery and form a hollow space in between for placement of the coffee material. The pod includes a flange around the periphery where the first filter material is fixed to the second filter material. The hollow funnel-shaped brew basket has a relatively wide top end and a relatively narrow bottom end. Both the top and bottom ends are open to allow the flow of liquid through the basket. A stepped support ring is integral in and defines a ledge around the circumference of the brew basket when the circumference is below the top end and below the bottom end.

[0010] In a still further example, a hot beverage maker brew basket comprises a hollow funnel-shaped brew basket having a relatively wide top end and a relatively narrow bottom end. Both the top and bottom ends are open to allow the flow of liquid through the basket. A first stepped support ring is integral in and defines a ledge around a circumference of the brew basket. The circumference is above the bottom end. A brew basket adaptor comprises a hollow funnel having a relatively wide top end and a relatively narrow bottom end. Both top and bottom ends are open to allow the flow of liquid through the adaptor. The adaptor further comprises a second stepped support ring that is integral in and defines a ledge around a circumference of the adaptor. The circumference is above the bottom end of the adaptor. The adaptor is mounted in the brew basket above the first stepped support ring. A first filter pod may be supported on its periphery by the first support ring, and a second filter is supported on its periphery by the second support ring. Also, the top end of the brew basket may define an upper edge having a diameter. The top end of the adaptor may comprise a flange, the adaptor flange may have a diameter greater than the diameter of the upper edge of the brew basket, whereby the adaptor is mounted in the top end of the brew basket as a result of the engagement of the adaptor flange with the upper edge of the brew basket. The bottom end of the adaptor defines a bottom edge, and the bottom edge may not contact the brew basket. Also, the adaptor may comprise a hinge connected to the brew basket.

[0011] In an additional example, a hot beverage maker brew basket comprises a hollow, funnel-shaped brew basket having a relatively wide top end and a relatively narrow bottom end. Both the top and bottom ends are open to allow the flow of liquid through the basket. A first stepped support ring is integral in and defines a ledge around a circumference of the brew basket, wherein the circumference is above the

bottom end. A brew basket adaptor comprises a hollow funnel having a top edge and a bottom edge, wherein the adaptor funnel is a second support ring. The adaptor is mounted in the brew basket above the first stepped support ring. A first filter pod is then able to be supported on its periphery by the first support ring, and a second filter pod may be supported on its periphery by the second support ring.

[0012] In another example, a hot beverage maker comprises a pod and a funnel-shaped brew basket. The pod comprises an amount of coffee material packaged within at least first and second sheets of filter web material. The sheets of filter web material are fixed to each other about their periphery and form a hollow space in between for placement of the coffee material. The pod includes a flange around its periphery where the first filter material is fixed to the second filter material. A brew basket has a relatively wide top end and a relatively narrow bottom end. Both the top and bottom ends are open to allow the flow of liquid through the basket. A first stepped support ring is integral in and defines a ledge around a circumference of the brew basket, wherein the circumference is above the bottom end. A brew basket adaptor comprises a hollow funnel having a relatively wide top end and a relatively narrow bottom end. Both top and bottom ends are open to allow the flow of liquid through the adaptor. The adaptor further comprises a second stepped support ring integral in and defining a ledge around a circumference of the adaptor, wherein the circumference is above the bottom end of the adaptor. The adaptor is mounted in the brew basket above the first stepped support ring. A first filter pod may be supported on its periphery by the first support ring, and a second filter pod may be supported on its periphery by a second support ring.

BRIEF DESCRIPTION OF THE DRAWINGS

[0013] **FIG. 1** is a perspective view of an automatic drip coffee maker type of device in which may be mounted a filter basket in accordance with the present invention.

[0014] **FIG. 2** is a perspective view of a filter basket in accordance with an example of the present invention.

[0015] **FIG. 3** is a perspective view of a filter basket as shown in **FIG. 2** further showing a coffee filter pod.

[0016] **FIG. 4** is a top plan view of the filter basket shown in **FIG. 2**.

[0017] **FIG. 5** is a side, cross-sectional view of the filter basket shown in **FIGS. 2 and 4** taken along line V-V in **FIG. 4**.

[0018] **FIG. 6** is a side elevation view of an alternative geometry of a brew basket in accordance with an example of the present invention.

[0019] **FIG. 7** is a perspective view of an alternative automatic drip coffee maker in which may be mounted a filter basket in accordance with the present invention.

[0020] **FIG. 8** is a perspective view of another example of a filter basket in accordance with the present invention.

[0021] **FIG. 9** is a top plan view of the filter basket shown in **FIG. 8**.

[0022] **FIG. 10** is a side elevation, cross-sectional view of the filter basket shown in **FIGS. 8 and 9**.

[0023] **FIG. 11** is a perspective view of a further example of a filter basket and adaptor in accordance with the present invention.

[0024] **FIG. 12** is an exploded, perspective view of a filter basket and adaptor and coffee pods in accordance with the present invention.

[0025] **FIG. 13** is a side elevation, cross-sectional view of a filter basket and adaptor and coffee pods as also shown in **FIG. 12**.

DETAILED DESCRIPTION

[0026] In order to overcome the problems of using filter pods in existing hot beverage makers, the brew basket may be modified to include a support ring. The support ring is designed to hold the filter pod in position to keep it from tilting or floating during the brew cycle. The support ring allows the filter pod to flow into the basket area during a brew cycle. The inside diameter of the support ring is designed to be large enough to provide enough flow rate of liquid through the pod to keep the pod from floating. The outside diameter of the ring is designed to be large enough to hold the largest size diameter of filter pods that are commercially available.

[0027] In order to solve the size/strength limitation of a beverage brewed from a single pod, the brew basket may be modified with the addition of an adaptor to allow a plurality of filter pods to be used in one brew cycle. This way, larger and/or stronger servings are possible. The adaptor is an additional support ring mounted in the top end of a brew basket. In this way, the brew basket may be used to mount one pod, while a second pod may be used with the adaptor.

[0028] The examples described herein demonstrate an adaptor for a single additional pod so that two pods may be used when preparing a brewed beverage. Of course other adaptors could be engineered so that two or more support rings are provided. As a result, three or more coffee pods could be used. The limitations of multi-pod adaptors may vary depending on the construction of a particular brewed beverage maker, the flow rates of the liquid, and other specific engineering details. The following claims are not limited to only the embodiments and examples shown and described in detail herein.

[0029] **FIG. 1** shows an automatic drip coffee maker 10 having an upper section 12 that is adapted to receive a brew basket 15. The brew basket 15 is removeably inserted into the coffee maker 10. In accordance with traditional, automatic drip coffee maker construction, the user will add fresh water to the coffee maker and place coffee grinds (or tea leaves) and a filter into the brew basket 15. The coffee maker 10 will heat the water and it will be supplied to the brew basket 15 from the upper portion 12 of the coffee maker 10. **FIG. 1** is provided merely to show an environment of a coffee maker that may receive a brew basket. Of course, different constructions of brew basket in accordance with the present invention may be mounted within multiple different types and styles of automatic drip coffee maker.

[0030] **FIGS. 2 through 5** illustrate different views of the same brew basket 15 shown in **FIG. 1**. The brew basket 15 includes funnel-shaped portions 17 and flange 18. The flange 18 is dimensioned and sized to be slideable into and out of a supporting lip in an automatic drip coffee maker. The

simple, horizontal flange **18** is merely an example of one geometry that works with a particular prototype coffee maker.

[0031] The funnel-shaped portion **17** of the brew basket **15** includes a top end **20** and top opening defined by the upper edge **21** of the top end **20**. There is also a bottom end **22** that includes an opening defined by the bottom edge **23** of the bottom end **22**. As shown, the funnel-shaped brew basket **15** is relatively wider at the top end **20** than the bottom end **22**. The brew basket **15** is hollow to allow the flow of liquid through the basket. A horizontal cross section of the brew basket **15** is circular as shown (see, e.g., **FIG. 4**). However, other cross-sectional geometries are possible including, but not limited to, oval, racetrack, square, rectangular, or other symmetric and asymmetric geometries.

[0032] The funnel portion **17** of the brew basket **15** further includes a ledge **25** that is a type of stepped support ring. The ledge **25** may be generally horizontal to the vertical orientation of the brew basket **15**. Alternatively, as shown in **FIG. 5**, the ledge **25** is more flat than the angle of the top end **20** and the bottom end **22**, but it still slopes downwardly at a gentle angle. The ledge **25** gradually turns into the bottom end **22** at a rounded portion **27**. The transition edge of the portion **27** may be rounded or sharp. The ledge **25** is a transition between the top end **20** and the bottom end **22** of the funnel portion **17**. The ledge **25** extends around the circumference of the brew basket **15** between the top and bottom ends **20** and **22** respectively. As shown, the ledge **25** defines a circular circumference around the brew basket **15**, and specifically the funnel portion **17** that is in the shape of a cone.

[0033] As shown in **FIGS. 3 and 5**, a coffee filter pod **30** contains an amount of coffee packaged within it (not shown) between first and second sheets of filter web material **31** and **32**. The amount of coffee material placed within the pod **30** may include, but is not limited to about 6 to 12 grams of material. Those sheets of filter material **31** and **32** are fixed to each other about their periphery and form a pocket in between for placement of the coffee material (or tea). The sheets **31** and **32** are secured around their periphery to form a flange **35**. The diameter of the circumference defined by the ledge **25** is sufficient to receive the coffee pod **30**, and specifically the flange portion **35** of the pod when it is placed in the filter basket **15**. In other words, the diameter of the coffee pod **d1** is adapted to be approximately the same as the diameter of the circumferential circle defined by the ledge **25**. When water is supplied to the brew basket, the flange **35** of the coffee pod **30** will seal to the stepped support ring that is shown as the ledge **25**. Additional hot water then will pass through the coffee pod **30** to be infused by the coffee matter and then pass out through the bottom opening **23**. The slope of the bottom end **22** allows for the coffee pod **30** to be drawn into the bottom portion **22**, at least in part, during brewing.

[0034] Filter pod **30** may also or alternatively contain other brewing solids in addition to coffee. This is also applicable with respect to filter pods **195** and **196** shown in **FIGS. 12 and 13**. For instance tea and various herbal teas may be placed within a filter pod. In order to cooperate with the brew basket as described, the dimensions of the pod should be as set forth above. The amount of tea material placed within a pod will vary according to the type of tea material being used to make a brewed beverage.

[0035] In one example, the outside angle to the horizontal of the bottom portion of the cone **22** is in the range of about 60° to 75°. The inside diameter of the support ring or ledge **25** is in the range of about 55 mm to 65 mm. In one example, the inside diameter is about 60 mm.

[0036] **FIG. 6** illustrates an alternative example of a filter basket **40** where the bottom end portion **45** defines a more flat cone than that shown in **FIGS. 2-5**. This filter basket **40** is merely an alternative example that demonstrates that different cones and different funnel shapes may be used in accordance with the teachings herein.

[0037] **FIGS. 7-10** illustrate a further example of a filter basket **60** displaying a still further different geometry from the cones shown in **FIGS. 1-6**. Referring first to **FIG. 7**, the coffee maker **50** includes the filter basket **60** that is placed into the coffee maker from the top of the coffee maker. A lid **54** is rotated open. The hot water showerhead **56** is rotatably connected to the lid **54** and raises when the lid is opened. This allows the filter basket **60** to be placed into and out of the coffee maker **50** from above. The filter basket **60** is placed inside the housing **52** of the coffee maker **50** so that the filter basket is suspended above the serving surface **58** where a coffee cup may rest and receive the infused beverage from the filter basket **60**.

[0038] Turning now to **FIGS. 8-10**, the filter basket **60** includes a flange **62** that supports the filter basket inside the coffee maker **50**. The flange **62** has a tab **61** extending upwardly therefrom to allow user to lift up out of and insert the brew basket into the coffee maker **50**. The top edge **64** of the top of the filter basket **60** defines the upper opening into which the hot water is passed into the filter basket. The conical shape of the filter basket **60** is comprised of the three parts—the upper end **66**, middle portion **68**, and lower end **70**. There is shown a ledge **67** that is the transition between the upper end **66** and middle portion **68**. The ledge **67** is a type of stepped support ring and has a relatively wide diameter to accommodate different size pod filters that may be placed into the filter basket **60**. Also, the ledge **67** is shown as being sloped between the upper portion **66** and middle portion **68**. This allows for the wetted pod to flow into or be drawn into, at least in part, the smaller cone shape that makes up the middle portion **68**. The low end **70** of the filter basket **60** is a relatively narrow funnel having an opening defined by the bottom edge **72** of the low end **70**. As shown, the low end **70** is configured off-center in the filter basket **60**. In other words, the low end **70** is offset to one side of the middle portion **68** cone shape. This off centering of the low end **70** is for the sole purpose of centering the low end **70** and opening **72** above a coffee cup that would be placed on the flat portion **58** of the coffee maker **50**.

[0039] Finally, this example of a filter basket **60** includes an overflow aperture **75** near the top edge **64** of the filter basket. The overflow aperture **75** prevents the unwanted leakage of water all around the top of the filter basket **60**. The aperture **75** guides the overflow, by way of surface tension, down the outside of the brew basket and guides it into the cup where the brewed beverage is deposited.

EXAMPLE

[0040] The performance of existing brew basket constructions was compared to a brew basket as shown in **FIGS.**

7-10 (referred to in the test as the POD Basket). The other constructions were a Black and Decker “Cup at a Time” basket, a Hamilton Beach CV-1 basket, and a regular funnel. In each case, a filter pod was simply placed into the brew basket.

[0041] Quantitative Test Methodology:

[0042] For each experiment the same coffee maker (Hamilton Beach CV1) was used. The coffee weight for each was at 9 grams. The same coffee pod was used as was 7 oz. distilled water for each test. After coffee was brewed it was allowed to cool to 70 deg. F. At this temperature the conductivity was measured to determine the coffee strength (extraction). The conductivity was measured using an Oakton Instruments TDS Tester model 35661-11, calibrated with a 1000 ppm solution before testing.

[0043] The following Table 1 contains the results of five trial tests.

TRIAL	PPM measured with Conductivity meter			
	POD Basket	Black and Decker Basket	CV-1 Basket	Actual Funnel without pressing in POD
1	1230	1000	820	1140
2	1180	1190	870	1160
3	1150	1100	760	830
4	1220	950	810	1230
5	1250	560	850	760
Avg.	1206	960	822	1024
Standard Deviation	36	216	37	190

[0044] As is evident from the test results, the average PPM (amount of extraction) is higher and standard deviation (consistent brew) lower for the example of the invention versus prior art brew baskets. This means that use of the improved brew basket yields a better extraction and more consistent results than the prior brew baskets.

[0045] **FIGS. 1-10** all illustrate the present invention when used in connection with single brewed beverage filter pod. However, it is possible to use two or more filter pods by modifying the apparatus shown. **FIGS. 11-13** show the brew basket of **FIGS. 8-10** further including an adaptor. The example shown in **FIGS. 11-13** illustrates the use of two pods. Different configurations are possible to use three or more pods in accordance with the teachings herein. The filter basket including the adaptor shown in **FIGS. 11-13** may be used in connection with hot beverage makers including, for instance, the coffee makers shown in **FIGS. 1 and 7**. The filter basket **60** of **FIG. 7** most closely resembles the filter basket **160** in **FIGS. 11-13**.

[0046] Referring now to **FIGS. 11-13**, the filter basket **160** includes a flange **162** that supports the filter basket inside a coffee maker such as, for instance, coffee maker **50** in **FIG. 7**. The flange **162** has a tab **161** extending upwardly therefrom to allow a user to lift up the brewed beverage filter basket **160** out of and insert it into a coffee maker. The top edge **164** of the top of the filter basket **160** defines the upper opening into which the hot water is passed into the filter basket. The conical shape of the filter basket **160** is comprised of three parts—the upper end **166**, the middle portion

168, and lower end **70**. There is shown a ledge **167** that is the transition between the upper and **166** and middle portion **168**. The ledge **167** is a type of stepped support ring and has a relatively wide diameter to accommodate different size pod filters that may be placed into the filter basket **160**. Also, the ledge **167** is shown as being sloped between the upper portion **166** and middle portion **168**. This allows for a wetted pod to flow into or be drawn into, at least in part, the smaller cone shape that makes up the middle portion **168**. The low end **170** of the filter basket **160** is a relatively narrow funnel having an opening defined by the bottom edge **172** of the low end **170**. As shown, the low end **170** is configured off center in the filter basket **160**. In other words, the low end **170** is offset to one side of the middle portion **168** cone shape. This off centering of the low end **170** is for the sole purpose of centering the low end **170** and opening **172** above a coffee cup that would be placed on the flat portion **58** of the coffee maker **50** shown in **FIG. 7**.

[0047] The filter basket **160** includes an overflow aperture **175** near the top edge **164** of the filter basket. The overflow aperture **175** prevents the unwanted leakage of water all around the top of the filter basket **160**. The aperture **175** guides the overflow, by way of surface tension, down the outside of the brew basket **160** and guides it into a cup where the brewed beverage is ultimately deposited.

[0048] Also disclosed in **FIGS. 11-13** is an adaptor **180** that is connected to the filter basket **160** via a hinge tab **190**. The hinge tab is inserted into the aperture **175** and allows the adaptor **180** to be hingedly connected to the filter basket **160**. The filter basket includes an upper end **182** and lower end **184**. There is also a ledge **186** that is the transition between the upper end **186** and lower end **184**. The ledge **186** is similar to the ledge **167** and the filter basket **160**. The ledge **186** is a stepped support ring and has a relatively wide diameter to accommodate different size pod filters that may be placed into the adaptor **180**. The inside diameter **188** of the ledge **186** is wide enough to allow a wetted pod to flow into or be drawn into, at least in part, the smaller cone shape that makes up the lower end **184**. The lower edge **185** of the low end **184** defines the bottom edge of the adaptor **180**. As best shown in **FIG. 13**, the bottom edge **185** of the lower end **184** is suspended above the filter basket **160**. A tab **194** and flange portions **192** abut against the flange **162** of the filter basket **160**. In this way, a filter pod **196** may be placed in the adaptor **180** at the same time that a second filter pod **195** is placed in the filter basket **160**.

[0049] An alternative adaptor not shown is like adaptor **180** except that the adaptor is itself the support ring. The alternative adaptor has a top edge and a bottom edge, however the walls of the adaptor would connect the top edge to the bottom edge by a substantially straight line. A simple support ring would be defined by the adaptor. The top edge could rest against a top edge of a filter basket like top edge **164** of filter basket **160**. The top edge could abut a bump in the top end of a filter basket. Also, tabs and/or a flange could be added to the top of the adaptor similar to tab **194** and flanges **192**.

[0050] Referring still to **FIGS. 11-13**, in operation a user may select one or two filter pods to use to make a brewed beverage. If using a single pod, the pod may be placed either in the adaptor **180** or in the filter basket **160**. Either way, the pod is supported by a support ring **186** or **167** in the adaptor

180 or filter basket **160** respectively. After hot water has been filtered through the filter pod and the brew cycle is complete, a user can either dump the used pod in the trash or remove the pod by hand and dispose of it. It is advantageous for the adaptor **180** to be connected to the filter basket **160** by a hinge **190** to facilitate disposal of a spent pod and retain the adaptor on the basket. The hinge **190** also allows simple access to the filter basket **160** for brewing or cleaning up after use.

[0051] While the invention has been described with reference to specific embodiments thereof, it will be understood that numerous variations, modifications and additional embodiments are possible, and all such variations, modifications, and embodiments are to be regarded as being within the spirit and scope of the invention.

What is claimed is:

1. A hot beverage maker brew basket comprising:
 - a hollow, funnel-shaped brew basket having a relatively wide top end and a relatively narrow bottom end, with both the top and bottom ends being open to allow the flow of liquid through the basket;
 - a stepped support ring integral in and defining a ledge around a circumference of the brew basket, wherein the circumference is above the bottom end;
 - a brew basket adaptor comprising a hollow funnel having a relatively wide top end and a relatively narrow bottom end, with both top and bottom ends being open to allow the flow of liquid through the adaptor,
 - the adaptor further comprising a second stepped support ring integral in and defining a ledge around a circumference of the adaptor, wherein the circumference is above the bottom end of the adaptor; and
 - wherein the adaptor is mounted in the brew basket above the first stepped support ring;
 - whereby a first filter pod may be supported on its periphery by the first support ring, and a second filter pod may be supported on its periphery by the second support ring.
2. A hot beverage maker brew basket as described in claim 1, wherein the brew basket and the adaptor each have a substantially conical shape that defines a substantially circular cross-section.
3. A hot beverage maker brew basket as described in claim 2, wherein the inside diameter of each of the first and second support rings is in the range of about 55 mm to 65 mm.
4. A hot beverage maker brew basket as described in claim 2, wherein the inside diameter of each of the first and second support rings is about 60 mm.
5. A hot beverage maker brew basket as described in claim 2, wherein the outside angle to the horizontal of the conical bottom end of the brew basket and the adaptor is each in the range of about 60 degrees-75 degrees.
6. A hot beverage maker brew basket as described in claim 1, wherein the top end of the brew basket defines an upper edge having a diameter, and the top end of the adaptor comprises a flange; and
 - further wherein the adaptor flange has a diameter greater than the diameter of the upper edge of the brew basket;

whereby the adaptor is mounted in the top end of the brew basket as a result of the engagement of the adaptor flange with the upper edge of the brew basket.

7. A hot beverage maker brew basket as described in claim 1, wherein the bottom end of the adaptor defines a bottom edge, and the bottom edge does not contact the brew basket.
8. A hot beverage maker brew basket as described in claim 1, wherein the adaptor comprises a hinge connected to the brew basket.
9. A hot beverage maker brew basket as described in claim 1, wherein the brew basket further comprises an overflow aperture proximate the top end of the brew basket.
10. A hot beverage maker brew basket as described in claim 1, wherein the inside diameter of each of the support rings is adapted to be approximately the same as the diameter of a filter pod.
11. A hot beverage maker brew basket comprising:
 - a hollow, funnel-shaped brew basket having a relatively wide top end and a relatively narrow bottom end, with both the top and bottom ends being open to allow the flow of liquid through the basket;
 - a first stepped support ring integral in and defining a ledge around a circumference of the brew basket, wherein the circumference is above the bottom end;
 - a brew basket adaptor comprising a hollow funnel having a top edge and a bottom edge, wherein the adaptor funnel is a second support ring;
 - and wherein the adaptor is mounted in the brew basket above the first stepped support ring;
 - whereby a first filter pod may be supported on its periphery by the first support ring, and a second filter pod may be supported on its periphery by the second support ring.
12. A hot beverage maker brew basket as described in claim 11, wherein the brew basket and the adaptor each have a substantially conical shape that defines a substantially circular cross-section.
13. A hot beverage maker brew basket as described in claim 12, wherein the inside diameter of each of the first and second support rings is in the range of about 55 mm to 65 mm.
14. A hot beverage maker brew basket as described in claim 12, wherein the inside diameter of each of the first and second support rings is about 60 mm.
15. A hot beverage maker brew basket as described in claim 11, wherein the top end of the brew basket defines an upper edge having a diameter, and the top end of the adaptor comprises a flange; and
 - further wherein the adaptor flange has a diameter greater than the diameter of the upper edge;
 - whereby the adaptor is mounted in the top end of the brew basket as a result of the engagement of the adaptor flange with the upper edge of the brew basket.
16. A hot beverage maker brew basket as described in claim 11, wherein the bottom end of the adaptor defines a bottom edge, and the bottom edge does not contact the brew basket.
17. A hot beverage maker brew basket as described in claim 11, wherein the adaptor comprises a hinge connected to the brew basket.

18. A hot beverage maker brew basket as described in claim 11, wherein the brew basket further comprises an overflow aperture proximate the top end of the brew basket.

19. A hot beverage maker brew basket as described in claim 11, wherein the inside diameter of each of the support rings is adapted to be approximately the same as the diameter of a filter pod.

20. A hot beverage maker for use with a pod comprising an amount of coffee material packaged within at least first and second sheets of filter web material, wherein the sheets of filter web material are fixed to each other about their periphery and form a hollow space in between for placement of the coffee material, and the pod including a flange around the periphery where the first filter material is fixed to the second filter material;

a brew basket having a relatively wide top end and a relatively narrow bottom end, with both the top and bottom ends being open to allow the flow of liquid through the basket;

a first stepped support ring integral in and defining a ledge around a circumference of the brew basket, wherein the circumference is above the bottom end;

a brew basket adaptor comprising a hollow funnel having a relatively wide top end and a relatively narrow bottom end, with both top and bottom ends being open to allow the flow of liquid through the adaptor,

the adaptor further comprising a second stepped support ring integral in and defining a ledge around a circumference of the adaptor, wherein the circumference is above the bottom end of the adaptor; and

wherein the adaptor is mounted in the brew basket above the first stepped support ring;

whereby a first filter pod may be supported on its periphery by the first support ring, and a second filter pod may be supported on its periphery by the second support ring.

21. A hot beverage maker as described in claim 20, wherein the brew basket and the adaptor each have a substantially conical shape that defines a substantially circular cross-section.

22. A hot beverage maker as described in claim 21, wherein the inside diameter of each of the first and second support rings is in the range of about 55 mm to 65 mm.

23. A hot beverage maker as described in claim 21, wherein the inside diameter of each of the first and second support rings is about 60 mm.

24. A hot beverage maker as described in claim 21, wherein the outside angle to the horizontal of the conical bottom end of the brew basket and adaptor is each is in the range of about 60°-75°.

25. A hot beverage maker as described in claim 20, wherein the diameter of the pod is in the range of from about 55 mm to 65 mm.

26. A hot beverage maker as described in claim 20, wherein the diameter of the pod is about 60 mm.

27. A hot beverage maker as described in claim 20, wherein the pod flange has a width in the range of about 5 to 15 mm.

28. A hot beverage maker as described in claim 20, wherein the amount of coffee material is in the range of about 6 to 12 grams.

29. A hot beverage maker as described in claim 20, wherein the brew basket further comprises an overflow aperture proximate the top end of the brew basket.

30. A hot beverage maker as described in claim 20, wherein the inside diameter of each of the first and second support rings is adapted to be approximately the same as the diameter of a filter pod.

* * * * *