



(19) **United States**

(12) **Patent Application Publication**
Du

(10) **Pub. No.: US 2006/0199469 A1**

(43) **Pub. Date: Sep. 7, 2006**

(54) **LAUNCHING DEVICE AND DISPOSABLE CARTRIDGE CONTAINING CONFETTI, PAPER DISCS OR FLUID**

(76) Inventor: **John (aka. Xiaoqiang) Du**, La Puente, CA (US)

Correspondence Address:
John (aka. Xiaoqiang) Du
2149 S. Joan Dr.
La Puente, CA 91745 (US)

(21) Appl. No.: **10/726,908**

(22) Filed: **Dec. 4, 2003**

Publication Classification

(51) **Int. Cl.**
A63H 37/00 (2006.01)

(52) **U.S. Cl.** **446/475**

(57) **ABSTRACT**

A multi-purpose launching device for propelling and disseminating confetti, paper disks or fluid contained in a

disposable cartridge. Contents of the cartridge as well as the outside surface of the launching tube may be covered with a fluorescent material. The top part of the launching tube may serve as a flagpole to supplement its primary function at large social gatherings such as sporting or music events, wedding ceremonies, holiday celebrations, presidential campaigns, etc. The device consists of a cylindrical launching apparatus and a cylindrical cartridge that may contain confetti, paper disks, fluid, or other soft materials such as fiber, string, fabric, etc. The bottom end of the upper section of the launching tube inserts into the lower section of the launching tube. After the cartridge is loaded on the top of the launcher, the lower section of the launching tube is pulled down at first, then pushed up by the user's hands, compress air within the tube, propelling contents of the cartridge to be ejected. A disabled cartridge is used for each shot. The cartridge is economical, its contents are flexible, and it is convenient and fast to change cartridges after each shot. The cartridge's top end has a foam cover, which may be made in various interesting or funny shapes, including rocket, fruit, or even men's sexual organ.

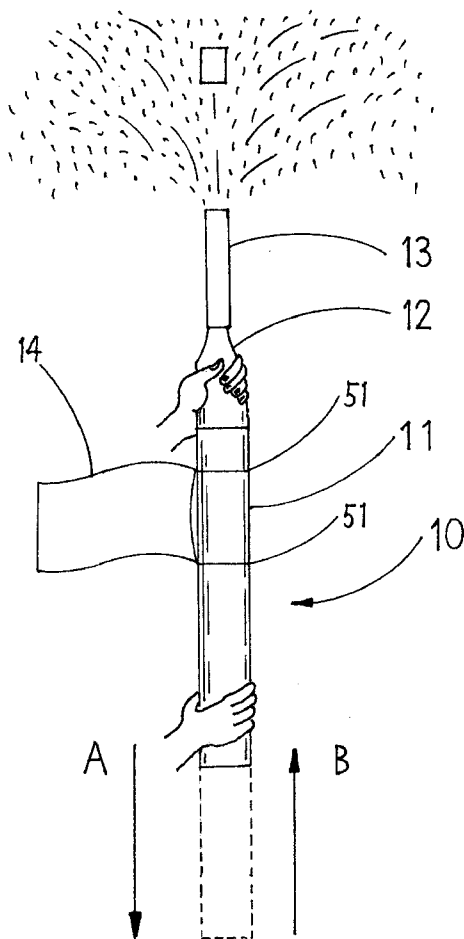

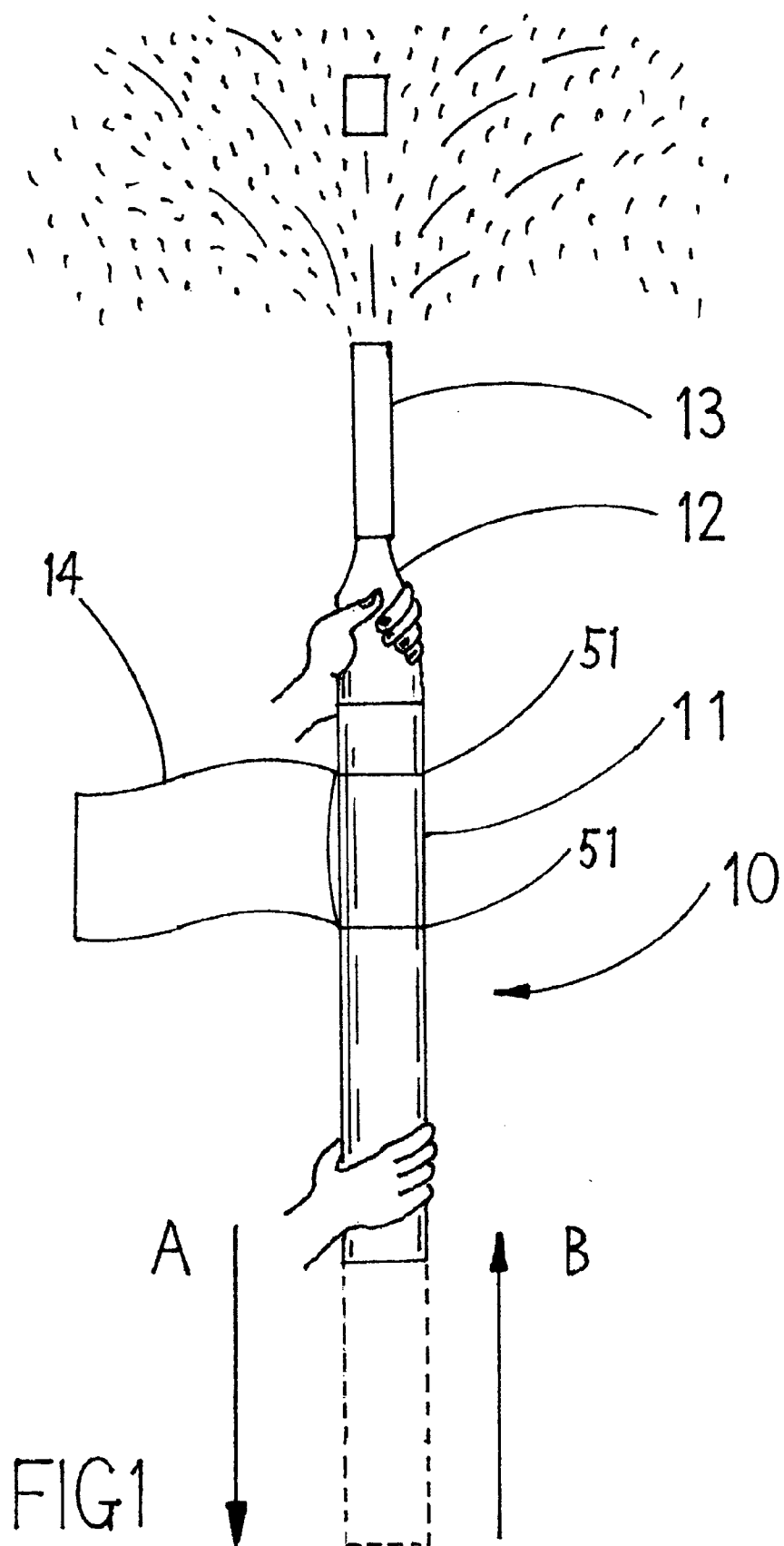

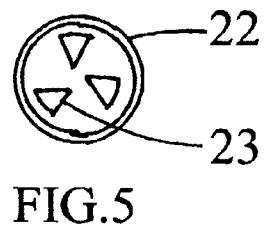
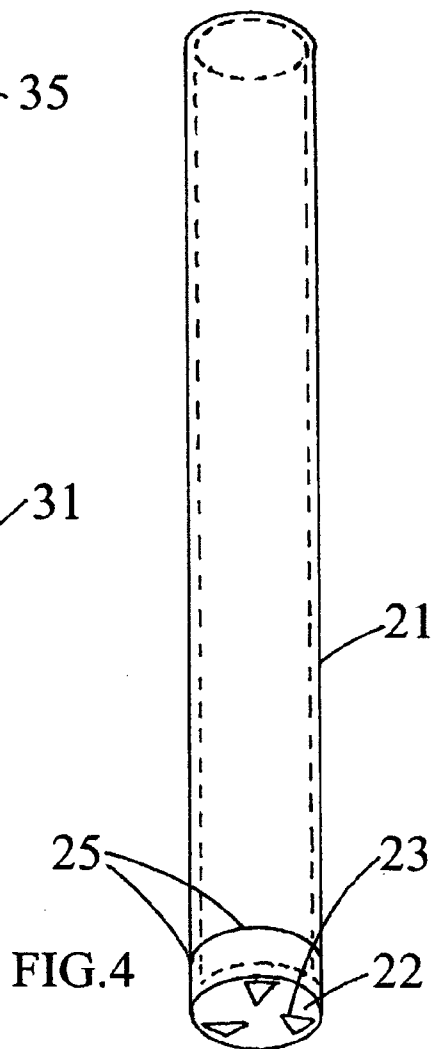
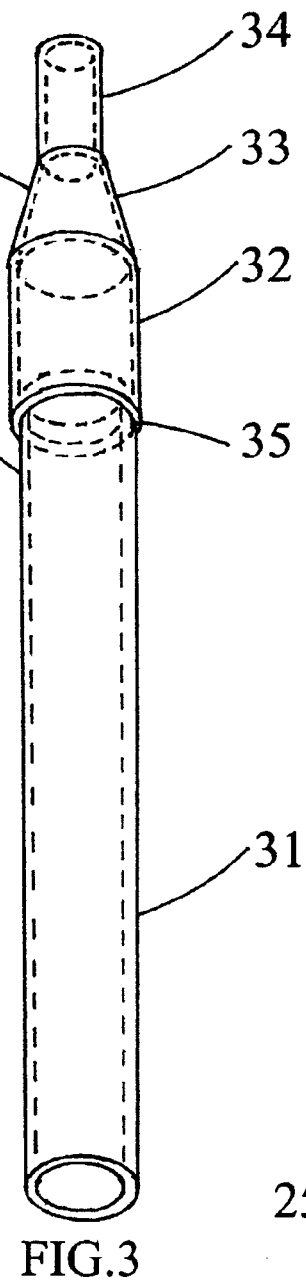
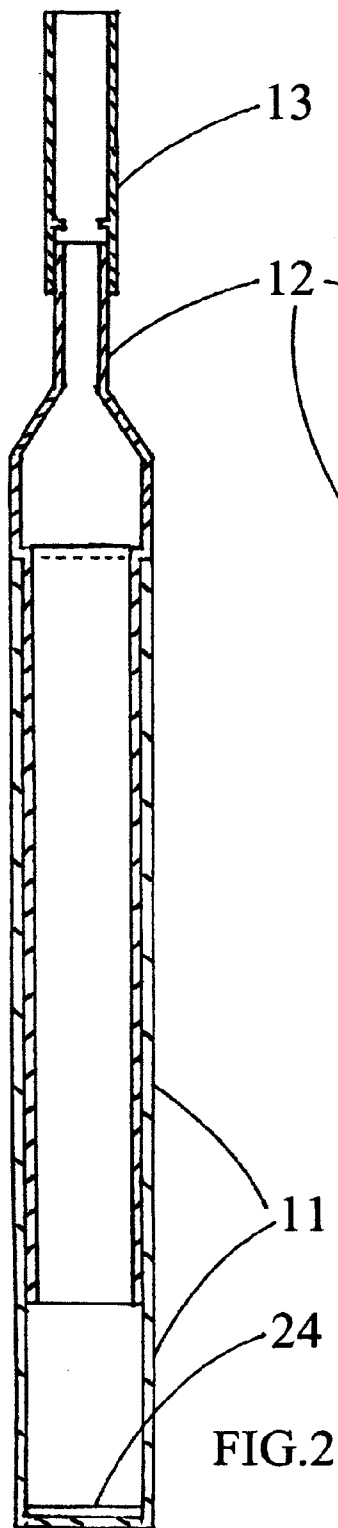

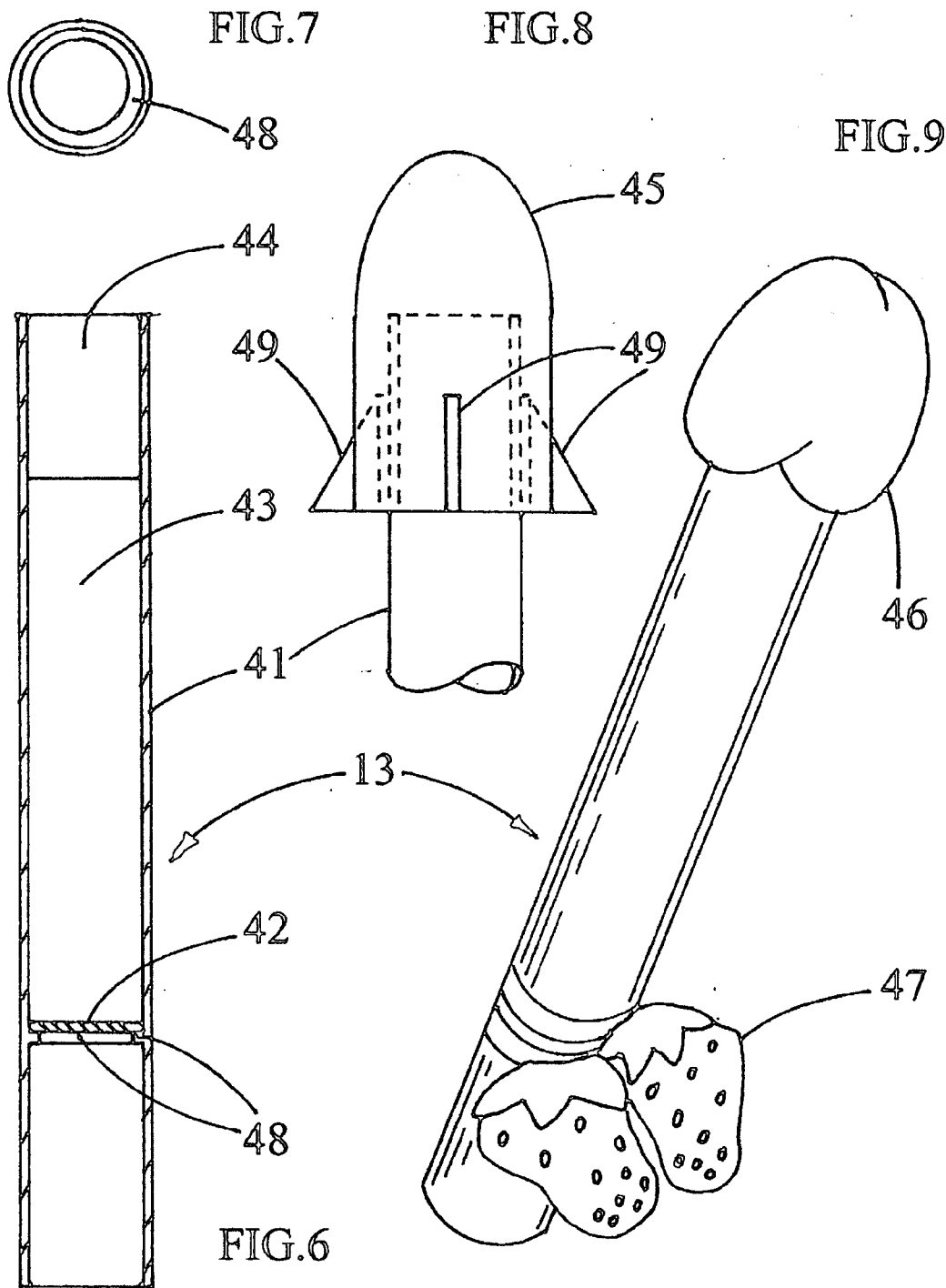

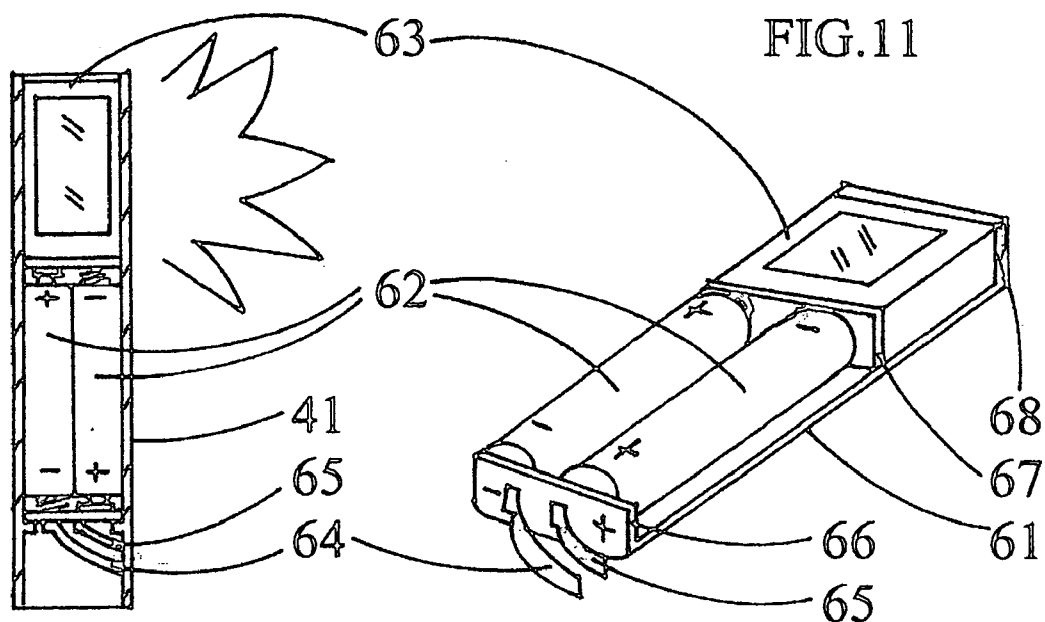

FIG. 10

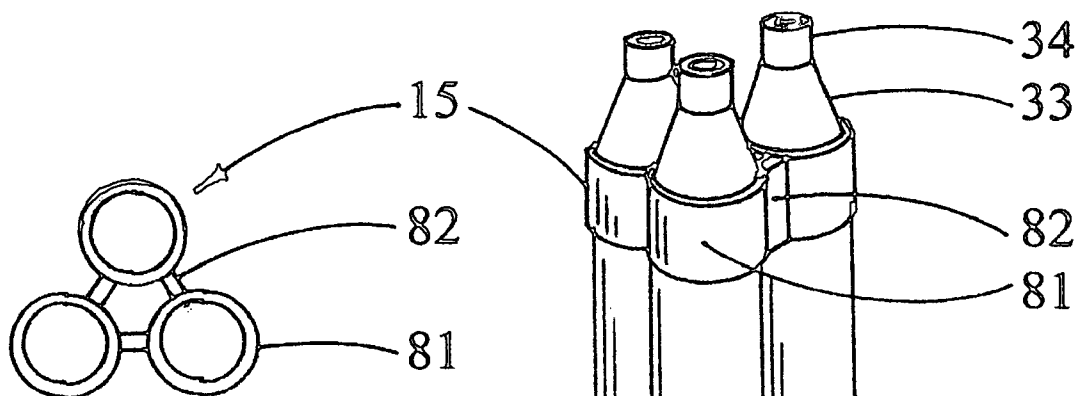

FIG. 12

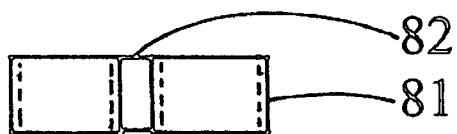

FIG. 13

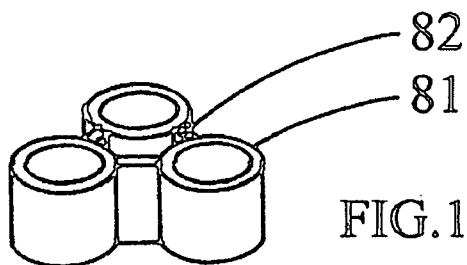

FIG. 14

FIG. 15

LAUNCHING DEVICE AND DISPOSABLE CARTRIDGE CONTAINING CONFETTI, PAPER DISCS OR FLUID

BACKGROUND OF THE INVENTION

[0001] The present invention relates to toy guns in general and more particularly to those that utilize compressed air to project confetti, paper, fiber, or fluid.

[0002] In recent years party confetti launchers with different types of launching power have been popular. Compressed air powered confetti launchers are among the most common types. Among the projectiles available are confetti and paper in different shapes.

[0003] The prior art involved confetti launchers driven by compressed air, springs, explosives, or the human mouth. Each of the following launchers projects confetti with explosives: U.S. Pat. No. 825,843 (Kliemandt); U.S. Pat. No. 1,324,092 (Worswick); U.S. Pat. No. 1,663,679 (Carpenter); U.S. Pat. No. 5,954,563. The following are confetti launchers that use compressed air contained cartridges as source of power: U.S. Pat. No. 5,015,211 (Reveen); U.S. Pat. No. 5,634,840 (Watkins); U.S. Pat. No. 5,722,491 (Watkins); U.S. Pat. No. 6,447,364 B1 (Song). U.S. Pat. No. 6,572,435 B1 (Wong) discloses a confetti launcher with springs as source of power. U.S. Pat. No. 1,153,207 (Eisenberg) and U.S. Pat. No. 1,491,809 (Macchia) use the user's mouth to blow out confetti.

[0004] The following two patents emphasize the visual effects of projectiles in dark surroundings. U.S. Pat. No. 5,415,151 (Fusi) involves a bullet-shaped phosphor-containing projectile that creates clear visual effects in darkness. The invention discloses a round capsule containing a phosphor-containing fluid. U.S. Pat. No. 6,048,280 (Palmer/Palmer) discloses a toy gun that projects a dart using as an agent compressed air generated by a drawn rod and a released spring. The gun contains a flash lamp to create the fluorescent effects of the propelled projectile. However, neither of these inventions projects confetti or it's like.

[0005] None of the above-mentioned launching devices has all 5 of following features, which differentiate them from the present invention: 1) none of them is powered by compressed air produced by the user's hands; 2) none of them has a separate, easily exchangeable cartridge for one-time use, containing various contents inside, including confetti, various soft materials or even fluid; 3) none of them has a foam top cover in various shapes for the cartridge, which will be launched simultaneously with content of the cartridge; 4) none of them uses fluid as projectile; 5) none of them uses fluorescent materials for creating special visual effects in the dark.

[0006] The present invention is entirely dissimilar from above-mentioned apparatuses. The present launching device is created for many time use, while the cartridge is designed for one time use. The combination makes this launcher cheaper, more interesting, easier for projecting various contents. The present invention uses the user's hands as the only power source, which makes it safer, easier to use than prior art, which use explosives, high pressure air container as the power source. The present apparatus uses different diameters between the upper end and the main body of the launching tube to increase air pressure within the launching tube, which makes the present apparatus more powerful than prior art involving the user's mouth or springs as power source. Additionally, the outside surface of the present invention

may be covered with fluorescent materials for decorative purposes. A flag may also be attached to the lower section of the launching tube. These and other features could be appropriate at sporting or music events, wedding ceremonies, holiday celebrations, parties, presidential campaigns, or other large social gatherings.

SUMMARY OF THE INVENTION

[0007] In consideration of disadvantages of known types of confetti launching devices, whose driving power is high pressure air contained in cylinder, explosive, the human mouth or springs, the present invention uses compressed air produced by the user's hands as driving power, which makes it safer, cheaper, easier to use and powerful enough for launching and disseminating projectiles. The separate, cheap, easily exchangeable cartridge, the foam top cover and the piece of cardboard or plastic disc at the bottom of the cartridge enable the present invention to easily contain, launch and disseminate soft projectiles such as confetti, paper disks, or even fluid.

[0008] The general purpose of the present invention is to provide a new, simply constructed device that uses compressed air as power source, produced by the user's hands for launching various projectiles from the cartridge. None of its advantages and new features have been shown or suggested in the prior art for confetti launching devices.

[0009] For this purpose, the present invention consists of two sections of a launching tube, a cartridge, a foam top cover and a piece of cardboard or plastic disc for containing the projectiles in the cartridge, and various types of projectiles, which will be described with all details later.

[0010] A primary object of the present invention is to provide a simple, cheap and easy to use projecting device capable of launching soft projectiles such as confetti, paper disks, or fluid for visual pleasure.

[0011] Another object is to provide a cartridge with a variety of possible contents, including but not limited to confetti paper disks, and fluid, which may be treated with fluorescent materials in order to create pleasant visual effects in the dark. Letters or words could also be printed on paper disks. The disks could also display messages such as proverbs and fortunes. Alternatively, they could show numbers and be used for drawing lots. Heart-shaped paper scraps may be used as projectile at wedding ceremonies for instance. To create a cheerful atmosphere, the substances being projected may also be scented.

[0012] A further object is to provide a projecting device in the form of a long stick, the cross section of which may be circular, triangular, rectangular, or any other shape. The advantage of a stick-like structure is that additional adaptations are possible. For instance, the device may be used as a flagpole.

[0013] Another object is to provide a simply-constructed and inexpensive projecting device. The simplicity of the structure makes this device affordable and easy to use.

[0014] Still another object is to provide a light-weight, simply-operated, safe and easy-to-carry projecting device able to be held in hands.

[0015] A further object is to provide a projecting device for repeated use and various cartridges with many different contents for one time use, which may be quickly and easily loaded and changed after each shot.

[0016] An additional object is to provide a projecting device at a much larger scale with the same structure as formerly described, in order to meet various demands on different occasions.

[0017] Another object is to provide a horizontal complex of projecting devices for ejecting projectiles from more than one device sequentially or simultaneously.

[0018] The device is further described using accompanying illustrated drawings.

BRIEF DESCRIPTION OF DRAWINGS

[0019] FIG. 1 is a side view of the present invention.

[0020] FIG. 2 is a sectional view of the present invention after the projectile is ejected.

[0021] FIG. 3 is a perspective view of the upper section 12 of the launching tube of the present invention shown in FIG. 2.

[0022] FIG. 4 is a perspective view of the lower section of the launching tube of the present invention shown in FIG. 2.

[0023] FIG. 5 is a plan view from the top of the lower section of the launching tube without the piece of circular foam plate 24 shown in FIG. 4.

[0024] FIG. 6 is a sectional view of the cartridge with the inside top cover shown in FIG. 2.

[0025] FIG. 7 is a plan view from the top of the cartridge after the projectile has been ejected.

[0026] FIG. 8 is a perspective view of the outside foam cover of the cartridge.

[0027] FIG. 9 is a side view of the cartridge with the outside foam cover in the shape of a peach and two foam decorations in the shape of strawberries.

DESCRIPTION OF THE PREFERRED EMBODIMENT

[0028] FIG. 1-2 show the present invention 10 completely. As shown in FIG. 2, the present projecting device 10 consists of a lower section 11 of the launching tube, an upper section 12 of the launching tube, a cartridge 13, and a flag 14. The flag 14 is fixed to lower section 11 of the launching tube by 2 elastic string rings 51.

[0029] As shown in FIG. 2-4, the inside diameter of the lower section 11 is a little larger than the outside diameter of the lower part 31 of the upper section 12 of the launching tube. The lower part 31 of the upper section 12 may easily insert into the lower section 11 of the launching tube and freely slide and reciprocate therein.

[0030] As shown in FIG. 2-3, the upper section 12 of the launching tube consists of 4 inseparable parts: the lower part 31 and the middle part 32 of cylindrical shape; the joint 33 of circular platform shape; and upper part 34 of cylindrical shape. There is an outside flange 35 at the conjunction between the lower part 31 and the middle part 32 formed by the wider diameter of part 32. The flange 35 stops the upward movement of the lower section 11 of the launching tube when the user pushes up the lower section of the launching tube to eject the projectiles.

[0031] As shown in FIG. 4-5, the lower section 11 has an open top end, the main body 21 and an enclosed bottom end 22. There are 3 fan-shaped holes 23 on the bottom end 22,

which is covered by a piece of circular foam plate 24 fixed with glue to the center of the bottom 22.

[0032] As shown in FIG. 6-7, the cartridge 13 consists of a container 41, a piece of cardboard or plastic disc 42, contents 43 and an inside top foam cover 44 or outside top foam cover 45 or 46. In the lower part and close to the bottom end of the said container 41, there is an inner collar flange 48, which holds a piece of cardboard or a plastic tape 42 for keeping the contents of the cartridge within the said container 41. If the contents of the cartridge 13 are confetti or paper disks, a piece of cardboard 42 is used on the bottom of the cartridge 13, and fluorescent materials may be added to contents of the cartridge for creating pleasing visual effects in the dark. If the contents of the cartridge 13 are paper discs, possibly in the shape of hearts (symbol of love) or just circular, lucky phrases or numbers for drawing lots may be printed on the paper disks. The solidity of the piece of cardboard should be such that the contents may leave the container 41 freely once compressed air hits the bottom of the cartridge 13. If the content is a fluid, waterproof plastic adhesive tape should be fixed on the collar flange 48 of the cartridge 13, and the bottom of said inside top foam cover 44 should also be covered with waterproof plastic tape in order to keep the fluid within the container 41 without leaking. The solidity of the waterproof plastic tape should be such that allows the expulsion of the fluid when compressed air hits the bottom of the cartridge 13.

[0033] As shown in FIG. 8, the said inside top foam cover 44 may be exchanged with outside top foam cover 45, which may in the shape of a bullet or of a rocket when three wings 49 are added.

[0034] As shown in FIG. 9, the outside top foam cover may be in interesting shapes of fruits, such as a peach shape, with decorations of two foam strawberries 47, fixed with plastic tape or glue on the outside of the lower part of the cartridge 13.

[0035] As shown in FIGS. 1, 2, 3, 4, and 6, before ejection, the user must put the bottom end of the cartridge 13 onto the open end of the upper part 34 of the upper section 12 of the launching tube. After that, as shown in FIG. 1, the user pulls the lower section 11 of the launching tube downwards in direction A, letting outside air into the launching tube through the holes 23 on the bottom 22. Because the foam plate 24 is fixed to the bottom 22 of the lower section 11 only in the center, it will not obstruct air inflow. The user then forces the lower section 11 of the launching tube upwards in direction B until the top end of the lower section 11 of the launching tube is stopped by the outside collar flange 35 of the upper section 12 of the launching tube. The air inside the launching tube can not flow out from the bottom end 22 of the lower section 11 of the launching tube because it is blocked by the foam plate 24 and is thereby rapidly compressed. The compressed air therein has to flow out through the top, hitting the piece of cardboard 42 and propelling the contents 43 of the cartridge 13 upwards into the air. The frictional force between top foam covers 44, 45, 46 and the wall of the container 41 of the cartridge 13 adds more force to the ejection process by increasing air pressure within the cartridge 13 upon ejection. The top foam covers 44, 45 and 46 may fly higher than contents of the cartridge, when the contents make more beautiful and pleasing view. The user may easily and quickly switch to a new cartridge, which makes present invention easy to use, cheap and fun.

[0036] As shown in FIG. 2-4, the upper section 12 and the lower section 11 of the launching tube may use plastic as the

raw material for injection processing. However, if the main body 21 of the lower section 11 of the launching tube is made of cardboard for lower cost, the bottom part 22 of the lower section 11 of the launching tube should be made by plastic and should have a side wall 25 surrounding the lower end of main body 21 of the launching tube. Glue may be used at the conjunction between the lower end of the main body 21 and the side wall 25 of the bottom part 22 of the lower section 11 of the launching tube for fixing the 2 parts together and to prevent air from leaking at ejection. The foam plate 24 may be made of plastic foam.

[0037] As shown in FIG. 6-9, the container 41 of the cartridge 13 may be made of some type of cheap plastic, since the cartridge is for one time use only. The foam top covers 44, 45 and 46, as well as the decorations 47 should be made by plastic foam.

[0038] Although the above description of the present invention includes illustrations and detailed explanations, it does not limit the present invention within the illustrations and descriptions. Some changes and modifications may take place within the scope of the present invention without modifying its basic principles.

1. A multi-purpose projecting device for propelling and disseminating confetti, paper disks, or fluid contained in a cartridge, comprising:

a launching tube having a circular cross section, comprising a lower section of cylindrical shape and an upper section with 3 parts—cylindrical upper and a lower parts, and a middle part of circular platform shape. The lower part of the upper section with smaller diameter may easily insert into the lower section of the launching tube for free slide and reciprocation therein to compress the air, propel and disseminate projectiles from the cartridge.

2. A plurality of cylindrical one time use cartridges, having an inner diameter equal to the outer diameter of the upper launching tube's upper end. The upper end of the launching tube's upper section inserts into the lower end of the cartridge, which consists of a container, a top foam cover, a piece of cardboard or plastic film for sealing the bottom of the cartridge and a plurality of contents, including confetti, paper disks, or fluid.

3. A flag, having 2-3 elastic string rings on one side for easily fixing said flag to the upper end of the launching tube or to the cartridge.

4. The invention as defined in claim 1 wherein said lower section of the launching tube having an open upper end and an enclosed lower end, the bottom of which has 3 fan-shaped holes around the center of the bottom, which is covered by a soft plastic disc, fixed to the center of the bottom with a dab of glue.

5. The invention as defined in claim 1 wherein said lower section of the launching tube may be made by plastic as one body, or by cardboard and plastic for its different parts: cardboard for the cylindrical main body and plastic for its bottom cover.

6. The invention as defined in claim 1 wherein the said upper section of the launching tube has 4 parts with different shapes and diameters: cylindrical shape for the upper,

middle and the lower parts and the circular platform shape for joining the upper and the middle parts. The diameter of the lower end of the middle part is bigger than the diameter of the lower part, forming where the two parts join, an outside collar for stopping the mutual movement between the upper and the lower sections of the launching tube, when the user pushes lower section up to compress air inside the tube and propel contents of the cartridge. The said upper section of the launching tube is made entirely by plastics.

7. The invention as defined in claim 2 wherein said contents of the cartridge include confetti paper disks, shaped papers, fluid, or other soft materials such as fiber, string, fabric, etc.

8. The invention as defined in claim 2 wherein said container of the cartridge is a hollow cylinder with an inner collar flange in the lower part and close to the lower end of the cartridge for holding said piece of cardboard or plastic tape and the contents of the cartridge within the container.

9. The invention as defined in claim 2 wherein the said cardboard may be changed to an adhesive piece of waterproof plastic tape for holding fluid within the tube, when fluid is loaded as the content of the cartridge.

10. The invention as defined in claim 2 wherein the said top foam cover at the top of the cartridge keeps contents within the container. It may have various shapes such as a cylinder, that can be inserted into the top end of the cartridge, a rocket shape surrounding and covering the top end of the cartridge, or other shapes such as fruit or even men's sexual organ.

11. The invention as defined in claim 10 wherein the said top foam cover may be waterproof if necessary by covering it with thin plastic film in order to keep contents from leaking when fluid is used as the content of the cartridge.

12. The invention as defined in claim 2 wherein said non-fluid contents may be covered with fluorescent materials for creating special visual effects in the dark.

13. The invention as defined in claim 2 wherein said paper disks may have lucky phrases and numbers for drawing lots printed on them when paper disks are used as contents of the cartridge.

14. The invention as defined in claim 2 wherein said fluid may have perfume to be added to it when fluid is used as the content of the cartridge.

15. The invention as defined in claim 2 wherein said cartridge may be made by transparent plastics with very bright flash-producing device or other flash-producing device inside the tube, such as a flash-producing device used for cameras. In this case, the flash device may have a switch on the bottom of the cartridge, which may trigger the flash to work when the user puts the cartridge's bottom end on top of the upper section of the launching tube.

16. The invention as defined in claim 2 wherein said cartridge is made for one time use. However, the user may easily refill the cartridge after each shot with new contents if so desired.

17. The invention as defined in claim 1 wherein said launching tube may have fluorescent materials covering its surface in order to create special visual effects in the dark.

* * * * *