

C. E. WHITEHEAD.
 ROAD GRADER.
 APPLICATION FILED DEC. 8, 1910.

999,934.

Patented Aug. 8, 1911.

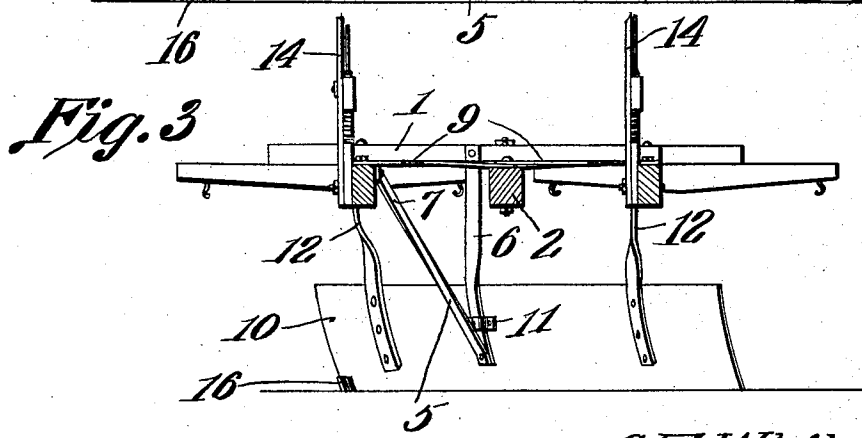
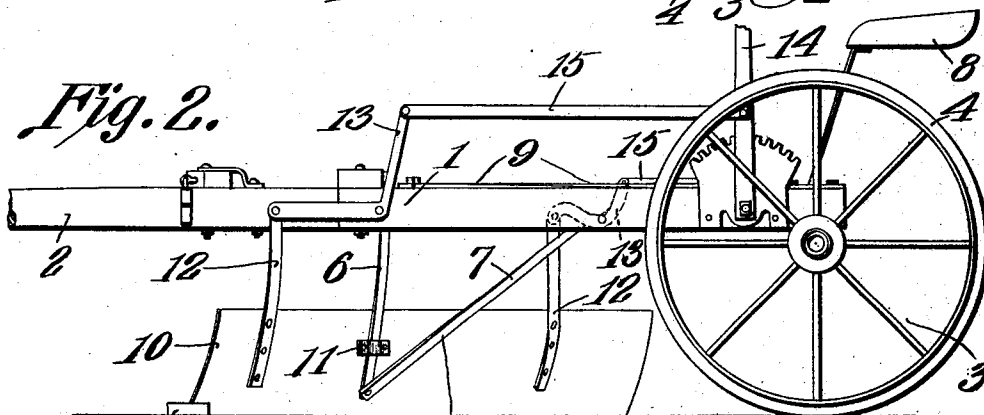
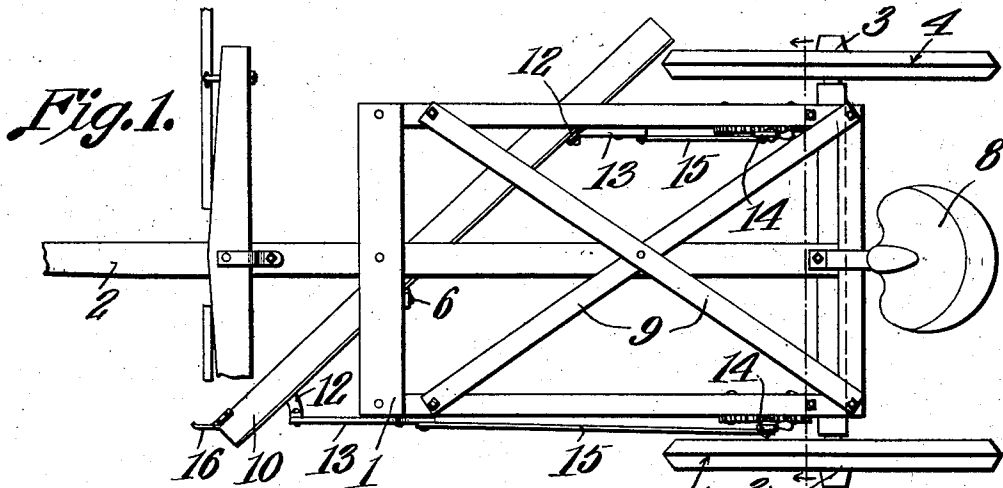

Witnesses

J. P. ...
J. Willow.

C. E. Whitehead,
 Inventor

by *C. A. Snow & Co.*
 Attorneys

UNITED STATES PATENT OFFICE.

CORNELIUS E. WHITEHEAD, OF OLLA, LOUISIANA.

ROAD-GRADER.

999,934.

Specification of Letters Patent.

Patented Aug. 8, 1911.

Application filed December 8, 1910. Serial No. 596,287.

To all whom it may concern:

Be it known that I, CORNELIUS E. WHITEHEAD, a citizen of the United States, residing at Olla, in the parish of La Salle and State of Louisiana, have invented a new and useful Road-Grader, of which the following is a specification.

This invention has relation to a road grader and consists in the novel construction and arrangement of its parts as hereinafter shown, described and claimed.

The object of the invention is to provide a road grader of simple structure and of durable nature which is especially adapted to withstand the strains and rough uses to which it is subjected.

With this object in view the grader includes a frame which is mounted at its rear portions upon supporting wheels. A scraper blade is supported at the forward end of the frame and lever mechanisms are provided for raising and lowering the end portions of the scraper blade independently of each other. A standard is attached to the frame and a clip is mounted upon the intermediate portion of the scraper blades and slidably receives the forward portion of the said standard. The standard is designed to brace the blade in position against the work that it has to do. A gage point is attached to the forward end of the blade and is adapted to prevent the same from entering too deeply into a bank of earth or other material to be operated upon.

In the accompanying drawing:—Figure 1 is a top plan view of the road grader. Fig. 2 is a side elevation of the same. Fig. 3 is a rear elevation of the scraper blade of the road grader and attached parts in section.

The road grader includes a rectangular frame 1 to which is attached a draft tongue 2. The rear portion of the frame 1 is supported upon the wheels 3 the rims 4 of which are approximately V-shaped in transverse section in order that the said wheels may engage the ground and be held against slipping sidewise. A standard 5 is secured to the intermediate portion of the frame 1 and the said standard consists of an approximately vertical portion 6 and a brace portion 7 which is connected at its forward end to the lower edge of the portion 6 and at its rear end to the intermediate portion of the said frame 1. An operator's seat 8 is mounted upon the rear portion of the frame 1, cross braces 9 are diagonally dis-

posed upon the frame 1 and serve as means for bracing the structure of the frame.

A scraper blade 10 is provided at its rear side with a clip 11 which slidably receives the approximately vertical portion 6 of the standard 5. Bars 12 are secured to end portion of the blade 10 and project above the upper edge of the same. Bell crank levers 13 are fulcrumed at the sides of the frame 1 and each of the said levers 13 is operatively connected with one of the end bars 12 mounted upon the said blade 10. Levers 14 are fulcrumed upon the frame 1 at the opposite side of the operator's seat 8 and links 15 operatively connect the levers 14 with the bell crank levers 13. A gage point or bar 16 is attached to the lower forward edge portion of the scraper blade and is adapted to govern the depth at which the scraper blade 10 will cut into banks of earth or other material.

From the above description it will be seen that an operator occupying the seat may operate one or the other of the lever mechanisms whereby one or the other of the end portions of the scraper blade 10 may be raised or lowered, or the said levers 14 may be swung both at the same time whereby both end portions of the said scraper blade will be raised or lowered. When the said scraper blade 10 is raised or lowered, the clip 11 may slide along the approximately vertical portion 6 of the standard 5 and wherever the said clip 11 may be upon the said portion 6 of the standard 5, the portion 6 will support the intermediate portion of the blade 10 in the work that it has to perform.

Having described the invention what I claim as new and desire to secure by Letters Patent is:

1. A road grader comprising a frame, wheels supporting the same, a standard depending from the frame and having an approximately vertical portion with a brace portion connected to the lower end of the vertical portion and also connected with the said frame, a scraper blade, a clip mounted upon the rear side of the scraper blade, said clip slidably receiving the approximately vertical portion of the standard, and lever mechanisms mounted upon the frame and operatively connected to the end portions of the said scraper blade.

2. A road grader comprising a wheel mounted frame, a standard depending from

said frame and having an approximately vertical portion with a brace portion connected to the said vertical and with the said frame, a scraper blade, a clip mounted upon
5 the rear side of the said blade, said clip slidably receiving the approximately vertical portion of the standard, lever mechanisms mounted upon the frame and operatively connected with the end portions of the
10 scraper blade, and a gage point connected to the lower forward edge of the said scraper

blade and adapted to limit the extent to which the said blade may enter a pile of material.

In testimony that I claim the foregoing as 15 my own, I have hereto affixed my signature in the presence of two witnesses.

CORNELIUS E. WHITEHEAD.

Witnesses:

C. F. WHITEHEAD,
F. BROWN.

Copies of this patent may be obtained for five cents each, by addressing the "Commissioner of Patents, Washington, D. C."
