

EUROPEAN PATENT APPLICATION

Application number: 82107916.7

Int. Cl.³: **C 14 B 1/26**

Date of filing: 28.08.82

Priority: 11.09.81 IT 3523

Date of publication of application:
23.03.83 Bulletin 83/12

Designated Contracting States:
AT CH DE FR GB LI NL

Applicant: Bonfiglioli, Sergio
Via Raibolini, 9
I-40069 Zola Predosa (Bologna)(IT)

Inventor: Bonfiglioli, Sergio
Via Raibolini, 9
I-40069 Zola Predosa (Bologna)(IT)

Representative: Modiano, Guido
MODIANO & ASSOCIATI S.A.S. Via Meravigli, 16
I-20123 Milan(IT)

Device for stretching hides from fur animals, such as minks, martens, sables, foxes.

The device comprises a support body (5) of elongate shape on which a hide (23), still in the tubular condition, is effective to be laid and secured at one end. The opposite end is gripped in gripping jaws (20d, 21d) and stretched as desired. Then, that end is secured on the support body (5) and the gripping jaws (20d, 21d) are removed. Thus, the hide will be held in the stretched condition on the support body (5), which may be replaced with another for putting a fresh hide under tension.

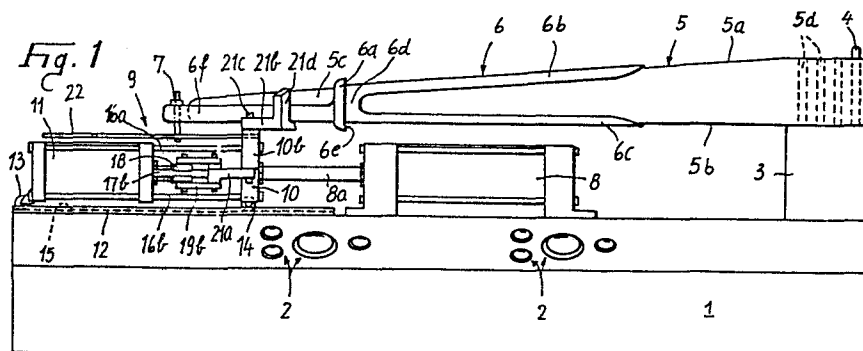

EP 0 074 546 A2

This invention relates to a device for stretching hides from fur animals, such as minks, martens, sables, and foxes. Obviously, though, the invention may be used for processing hides from other animals, which
5 require to be stretched.

As is known, the hides from fur animals of the above varieties must be subjected to stretching treatments to enhance the value of the furred side. It is current practice to perform such stretching
10 operations manually. For this purpose, an operator will first soften the hide by wetting it and then lay it onto a surface while stretching it mainly in a longitudinal direction. The hide is secured by nailing
15 it along its periphery; it is then allowed to stay in this condition until dry, and subsequently cut into strips for the following sewing operations.

It will be appreciated from the foregoing that traditional stretching methods are somewhat uneconomical. In particular, they have very heavy skilled labor
20 requirements, while the working times are excessively long.

Another negative aspect of conventional methods is that they require the availability of large size workbenches which take up considerable space.

25 Accordingly the task of this invention is to provide a device whereby the operations listed herein above can be fully automated.

Within this task it is an object of the invention to provide such a device which is simple in construction, reliable

in operation, and can afford a significant reduction of its space requirements.

According to one aspect of the present invention, the aforesaid task and object as well as yet other objects which will become more apparent hereinafter are achieved
5 by a device for stretching hides from fur animals, such as minks, martens, sables, and foxes, characterized in that it comprises a base, a hide holder or support body of elongate shape and articulated barndoor-
10 like to said base in a detachable way, a hide being effective to be laid on said holder or support body and secured to said base with the end closest to the articulation point, a backing or biasing element adapted to be superimposed on the free portion of said support
15 body and being slidable with respect thereto between a position near said articulation point, wherein said backing element underlies that end of said hide opposite to the end thereof secured prior to the stretching operation, and a position spaced apart from said
20 articulation point, a carriage arranged to be movable in a parallel direction to said support body, actuator means for reciprocating said carriage between said two positions, gripping members mounted on said carriage and driven to grip said hide end tightly against said
25 backing element at said near position and release said end at said spaced apart position after the last-mentioned end has been secured onto the terminating portion of said support body in the stretched condition of said hide.

30 Further advantages and features of this invention will be more clearly apparent from the following descrip-

tion of a preferred embodiment thereof, with reference to the accompanying drawings, where:

Figure 1 is a longitudinal elevation view of a hide stretching device according to the invention;

5 Figure 2 is a plan view of the device of Figure 1;

Figures 3,4 and 5 illustrate three successive steps in the operation of the device.

10 Making reference to Figures 1 and 2, this device comprises a base 1 of box-like design and being elongated horizontally, on the front whereof are arranged control pushbuttons, generally indicated at 2.

To the base 1, there is affixed a baseboard 3 from which a pin 4 extends vertically upwards. To the pin 4 is articulated a horizontally elongated body 5 which tapers towards its free end. The body 5 is flattened and has its top 5a and bottom 5b edges rounded off. Whereas the bottom edge is horizontal, the top edge slopes down from the articulation point towards the free end. The body 5 constitutes the support or holder on which the hide, after it has been stretched, will stay attached. On the body or support 5 a backing or biasing element 6 is superimposable which comprises a collar 6a having a complementary shape to that of the support and from which there extend two extensions 6b and 6c adapted to cover the edges 5a and 5b of the support 5 over a certain length. In the proximity of the collar 6a, the extensions 6b and 6c are interconnected together by an annular portion 6d which, along with the collar 6a, defines a shoulder 6e.

30 At the opposite side to that of the extensions

6b and 6c, the backing or biasing element 6 is provided with an additional extension 6f which covers the bottom edge of the support 6 and has one end formed with a through hole for the insertion of a vertical pin 7 which, in the inserted position thereof, protrudes beneath the extension 6f. Figure 4 shows a sectional view through the end of the extension 6f.

As may be seen in Figure 1, with the backing element superimposed on the support, the terminating portion 5c of the latter is inserted through the extension 6f. Between the top surface of the base 1 and bottom edge 5b of the support 5, there is defined a space wherein the active means of the device are accommodated. Such means comprise a pneumatic or air-operated cylinder 8 which is mounted on the base 1 such that its longitudinal axis is parallel to the support 5. The rod of the cylinder 8, indicated at 8a, is connected to a carriage or slider, generally indicated at 9. The carriage 9 is composed of a plate 10 therewith, by means of four tie rods arranged in cruciform configuration, is made rigid a further pneumatic or air-operated cylinder 11, aligned with the cylinder 8. The carriage 9, upon actuation of the cylinder 8, is reciprocated along a rail 12, on which the carriage can roll by means of a pair of wheels 13, 14 mounted idle on the plate 10 and in the base of the cylinder 11. Expediently, the wheels are caused to run in a longitudinal groove 15 of the rail 12 to avoid lateral deflections of the carriage. Of the four tie rods whereby the cylinder 11 is secured to the plate

10, two tie rods, 16a and 16b, extend in a vertical plane, whereas the other two, 17a and 17b, extend in a horizontal plane. On the latter is guided slidably a shoe 18 attached to the rod 11a of the cylinder 11.

5 Above the shoe 18, there is articulated a slightly angled link 19a, while a similar link 19b is articulated below the shoe about the same vertical axis. The links 19a,19b are swivel connected with two-arm levers 20,21, said levers being pivoted

10 at side wings 10a,10b of the plate 10. The arms 20a, 21a of the levers 20,21 are articulated under the wings 10a,10b and connected to the links 19a,19b, the other two arms 20b,21b being articulated above said wings. Said other or upper arms 20b,21b are rotatively coupled to the

15 lower ones 20a,21a by means of pivot pins 20c,21c which are set rotatable in the wings 10a,10b, to which pins the arms are keyed.

It should be noted that the lower arms 20a,21a are articulated respectively below the link 19a and

20 above the link 19b, so that they extend in one and the same horizontal plane. To the free ends of the upper arms 20b,21b, there are connected respective jaws 20d,21d whose faces are facing toward the backing element 6 and mate the shape of the annular portion 6d.

25 The device is completed with a strap 22 formed with aligned holes 22a, which is affixed to the plate 10 and projects cantilever-like above the carriage 9 and parallel to the running direction of the latter.

The operation of the device just described will

30 be apparent from Figures 3-5. A hide 23 to be stretched,

while still in a tubular form and indicated in dash lines in Figures 3-5, is superimposed on the support 5 and backing element 6 and secured at one end by nailing or stapling. This operation may be carried out
5 separately, before the support is engaged with the pivot pin 4. After placing the support on the base, the cylinder 8 is actuated in the direction to bring the carriage 9 to its right travel limit, as viewed in Figure 1. Then, the cylinder 11 is actuated which,
10 up to now, had been in its retracted condition with the jaws 20d,21d in the opened condition. The actuation of cylinder 11 controls the closing of the jaws onto the annular portion 6d of the backing element 6. Thus, the yet free end of the hide is caused to be clamped
15 against said portion 6d. This situation, illustrated in Figure 3, is followed by the extension of the cylinder 8, which causes the carriage 9 to move to the left. At the same time, the engagement of the jaws with the portion 6d and the abutment against the shoulder 6e
20 produce an entrainment of the element 6 with respect to the support 5, and accordingly the stretching of the hide (Figure 4). Upon completion of the cylinder 8 stroke, the hide is secured in the stretched condition by means of nails or staples 25 driven into the support near
25 the annular portion 6d between the extensions 6b and 6c. The entraining action of the backing element by the jaws 20d,21d may be aided by the pin 7 engaging in a corresponding hole 22a in the strip 22. Lastly, the element 6 is drawn out, after opening the jaws 20d,21d.
30 This drawing action may be accomplished by causing the



carriage 9 to complete an additional travel or by repeatedly actuating the cylinder 8 and simultaneously shifting the pin 7 into the holes 22a. As is apparent from Figure 5, the hide stays in the elongated
5 condition on the support, which may be removed to allow the installation of another support and the processing of another hide.

As may be seen from the foregoing, the inventive device fully achieves its objects. The hide stretching
10 operations are greatly speeded up. The hide itself does not get damaged. In particular, the extensions 6b, 6c ensure an evenly applied tension and contribute to holding the element 6 guided.

In practicing the invention, many modifications
15 and variations become possible without departing from the protection scope of this application. Thus, as an example, the hides may be secured to the support by providing clamps incorporated to the support itself. The device may be adapted to fit different
20 hide lengths by providing linearly offset holes 5d for engagement by the pin 4. The articulation of the support in one of said holes also allows the amount of stretching to be changed while keeping the stroke length of the cylinder 8 constant. Of course, the
25 amount of stretching may be determined by adjusting the stroke length of the cylinder 8.

In practicing the invention, the technical details may be replaced with other full equivalents.

CLAIMS

1 1. A device for stretching hides from fur animals,
2 such as minks, martens, sables, and foxes, characterized
3 in that it comprises a base (1), a hide holder or
4 support body (5) of elongate shape and articulated
5 barndoor-like to said base (1) in a detachable way, a
6 hide (23) being effective to be laid on said holder
7 or support body (5) and secured to said base (1) with
8 the end closest to the articulation point, a backing
9 or biasing element (6) adapted to be superimposed on
10 the free portion of said support body (5) and being
11 slidable with respect thereto between a position near
12 said articulation point, wherein said backing element
13 (6) underlies that end of said hide opposite to the
14 end thereof secured prior to the stretching operation
15 and a position spaced apart from said articulation
16 point, a carriage (9) arranged to be movable in a
17 parallel direction to said support body (5), actuator
18 means (8) for reciprocating said carriage (9) between
19 said two positions, gripping members (20d, 21d)
20 mounted on said carriage (9) and driven to grip said
21 hide end tightly against said backing element (6)
22 at said near position and release said end at said
23 spaced apart position after the last-mentioned end
24 has been secured onto the terminating portion of
25 said support body (5) in the stretched condition of
26 said hide (23).

1 2. A device according to Claim 1, characterized
2 in that said support body (5) is flattened and tapers
3 toward the free end thereof.

1 3. A device according to Claim 2, characterized
2 in that said backing or biasing element (6) comprises
3 a collar (6a) of complementary shape with the shape of
4 said support body (5), wherefrom there extend two
5 extensions (6b, 6c) adapted to cover, at least in part,
6 the top and bottom edges of said support body (5), and
7 being connected, near said collar (6a), to each other
8 by an annular portion (6d) effective to define a
9 shoulder (6e), said backing element (6) having, on the
10 opposite side to said extensions (6b, 6c), an addi-
11 tional extension (6f) the end whereof is formed with
12 a through hole for the insertion of a pin (7) therein
13 adapted to be coupled to a strap (22) attached to
14 said carriage (9) for the entrainment thereof.

1 4. A device according to Claim 1, characterized
2 in that said gripping members comprise a pair of
3 jaws (20d, 21d) associated with levers (20b, 21b)
4 actuated by a jack, said jaws (20d, 21d) being
5 operative to clamp around the annular portion (6d) of
6 said backing element (6).

1 5. A device according to Claim 4, characterized
2 in that said carriage (9) is movable by means of
3 an air operated cylinder or jack (8) aligned with
4 the jaw actuating air operated cylinder or jack (11).

1 6. A device for stretching hides from fur
2 animals, such as minks, martens, sables, and foxes,
3 according to the preceding claims, and substantially
4 as herein described and illustrated.

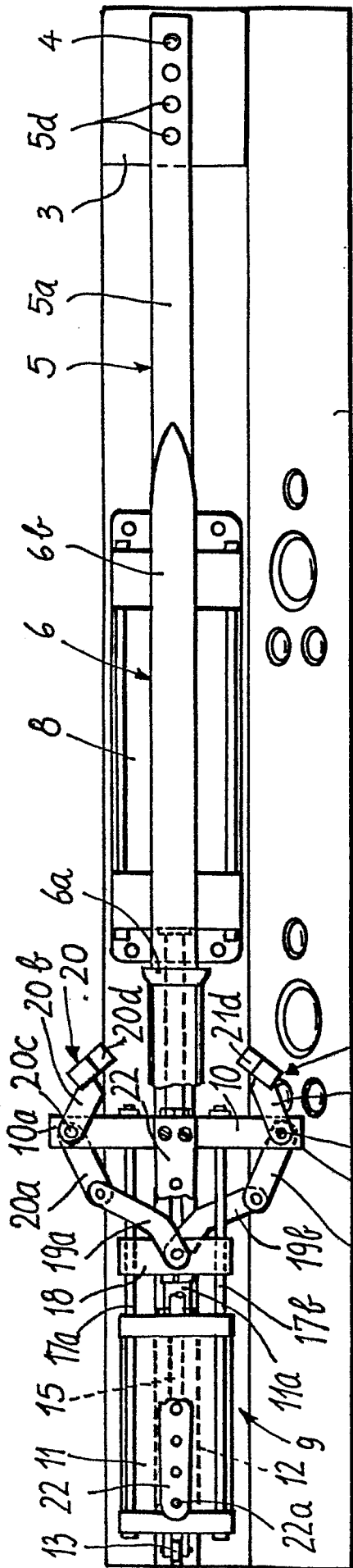

Fig. 2

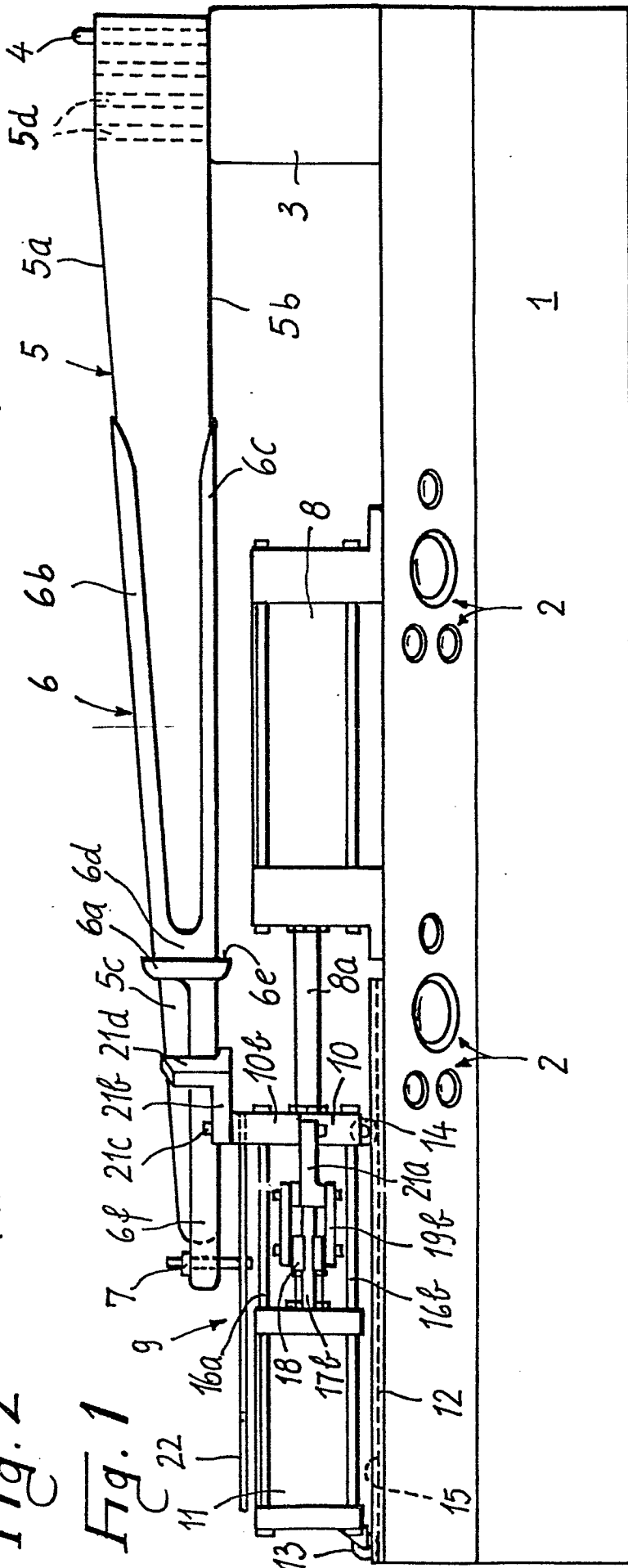

Fig. 1

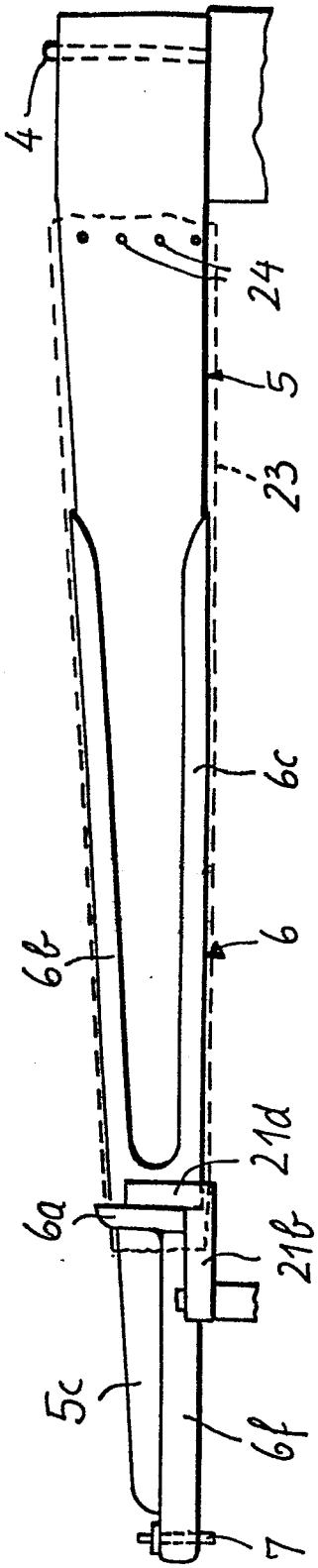

Fig. 3

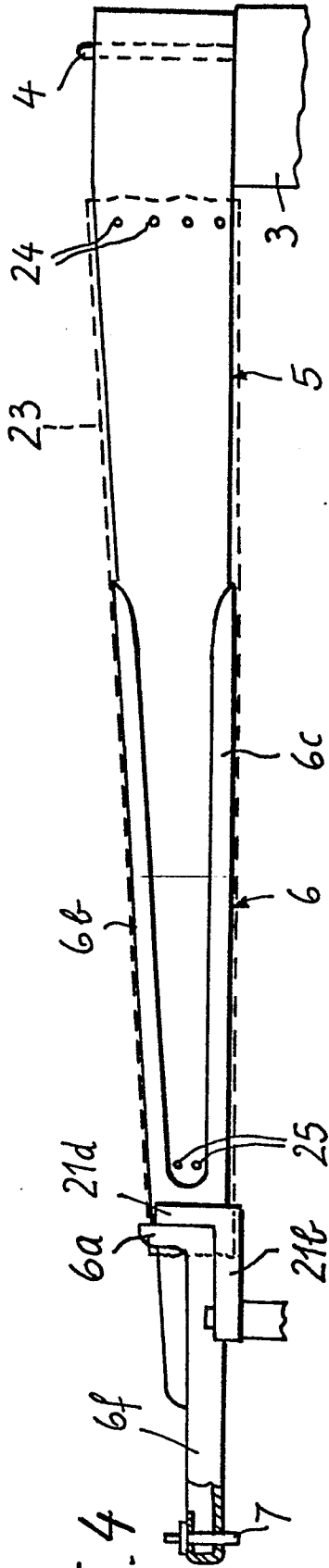

Fig. 4

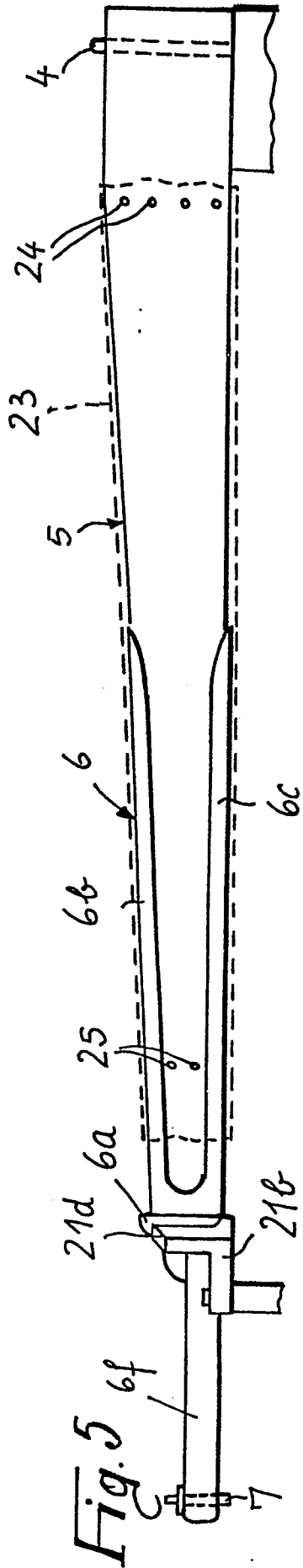

Fig. 5