

(No Model.)

3 Sheets—Sheet 1.

J. J. & G. J. DALEY.

MACHINE FOR MAKING LEATHER EDGINGS, &c.

No. 386,187.

Patented July 17, 1888.

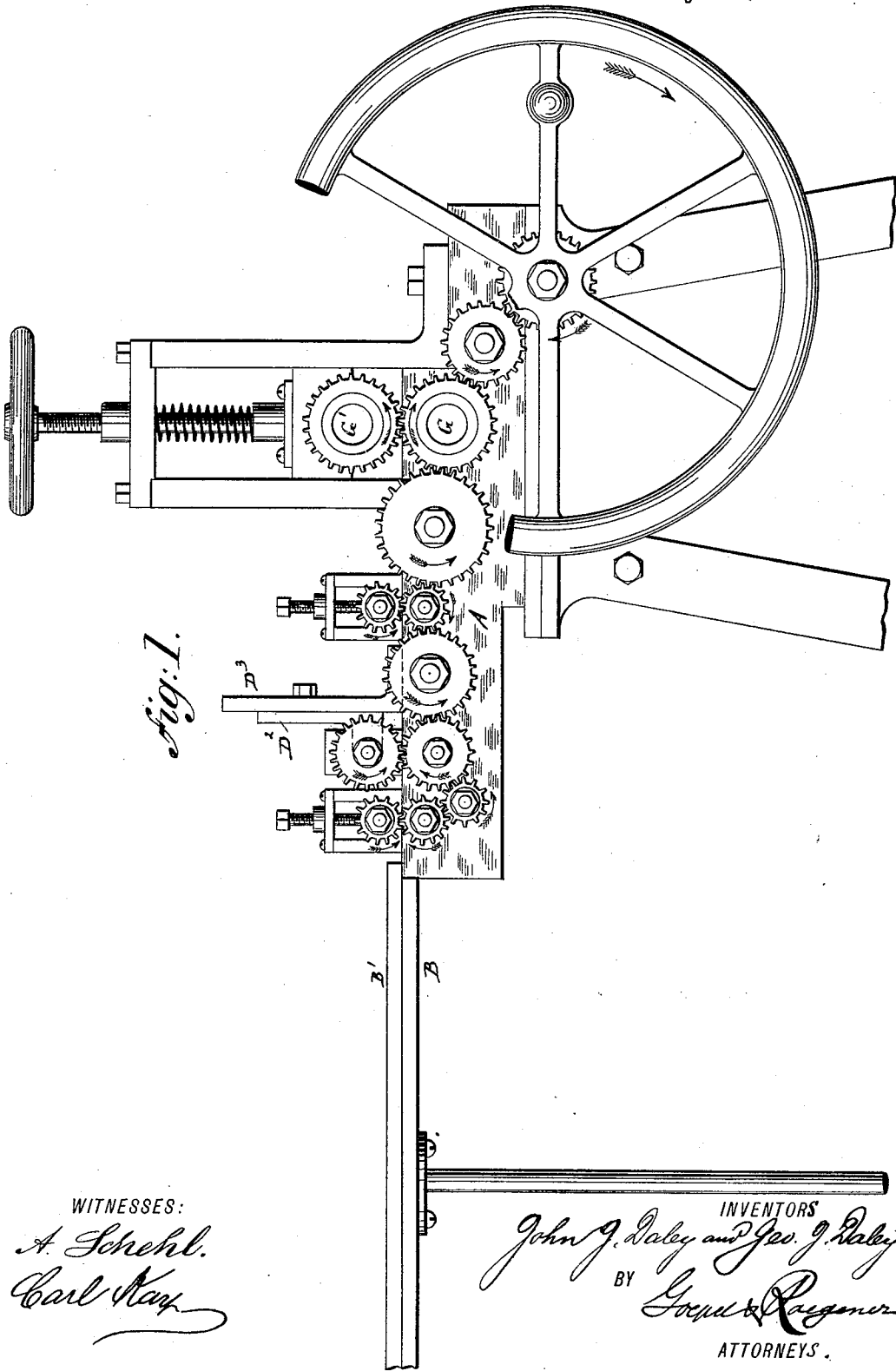

Fig. 1.

WITNESSES:

A. Schehl.
Carl Kay

INVENTORS

John J. Daley and Geo. J. Daley

BY

Good & Reasoner

ATTORNEYS.

(No Model.)

3 Sheets—Sheet 2

J. J. & G. J. DALEY.

MACHINE FOR MAKING LEATHER EDGINGS, &c.

No. 386,187.

Patented July 17, 1888.

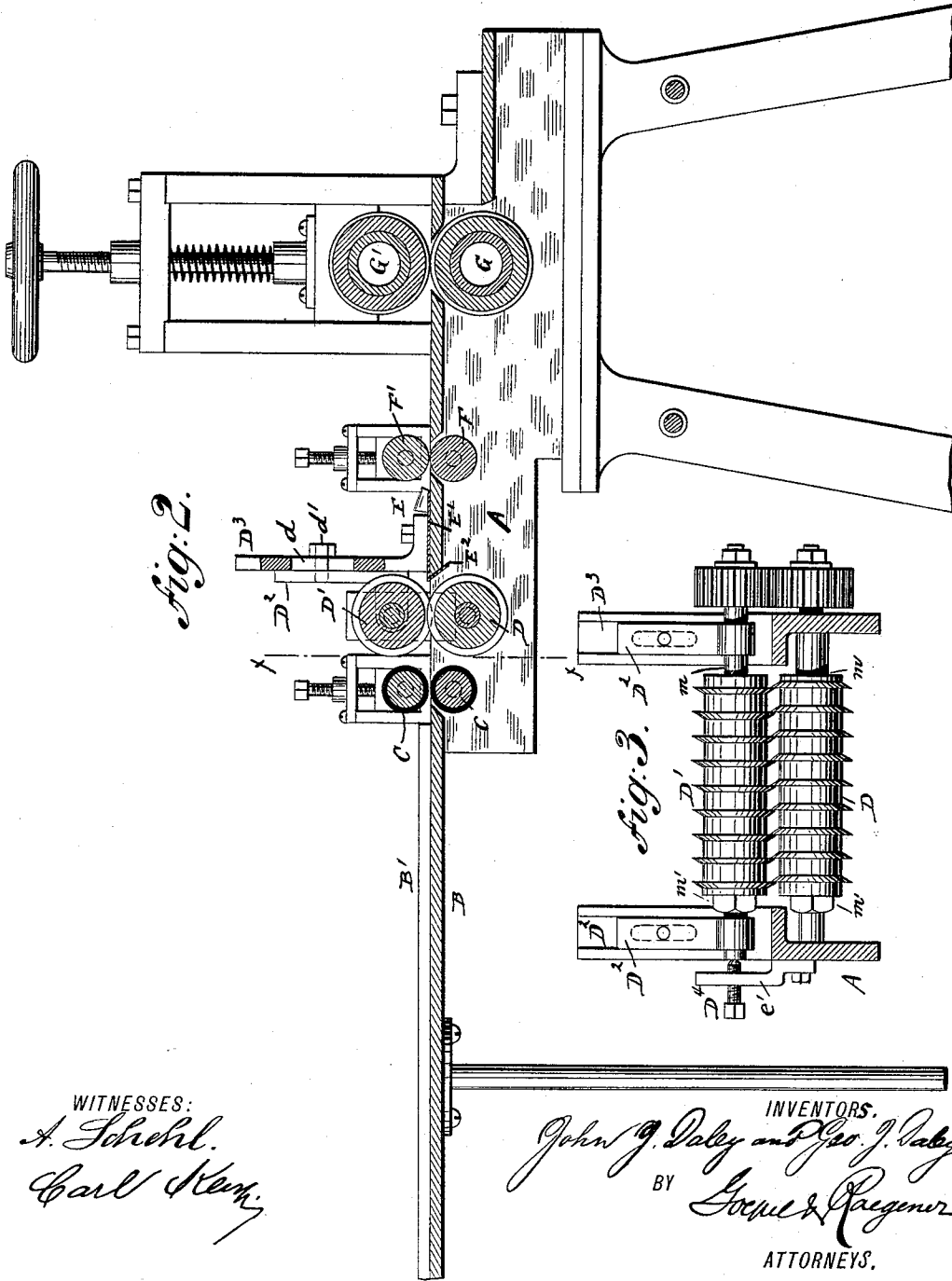

WITNESSES:
A. Schehl.
Carl Kern.

INVENTORS.
John J. Daley and Geo. J. Daley
 BY *Looney & Regener*
 ATTORNEYS.

UNITED STATES PATENT OFFICE.

JOHN J. DALEY AND GEORGE J. DALEY, OF BROOKLYN, ASSIGNORS, BY
MESNE ASSIGNMENTS, TO JOHN H. SEED, OF NEW YORK, N. Y.

MACHINE FOR MAKING LEATHER EDGINGS, &c.

SPECIFICATION forming part of Letters Patent No. 386,187, dated July 17, 1888.

Application filed December 9, 1887. Serial No. 257,420. (No model.)

To all whom it may concern:

Be it known that we, JOHN J. DALEY and GEORGE J. DALEY, both of Brooklyn, in the county of Kings and State of New York, have
5 invented certain new and useful Improvements in Machines for Making Leather Edgings and Gimps, of which the following is a specification.

This invention relates to an improved machine for making creased and ornamented leather edgings, bindings, and the like in a quick, uniform, and regular manner.

The invention consists of a machine for making leather edgings which is composed of a
15 pair of feed-rolls, a pair of cutter-rolls having circular knives, a series of rollers in line with the cutting-knives, an intermediate pair of feed-rolls, and a pair of creasing or ornamenting rolls, which are arranged in connection
20 with the feed-table, and a suitable driving mechanism, by which motion is imparted to all the rolls from a driving-shaft. The upper cutter-roll is vertically adjustable toward the lower roll by making its bearings vertically
25 adjustable in slotted upright standards and laterally adjustable in said bearings by a set-screw bearing on one end of its shaft, as will appear more fully hereinafter, and finally be pointed out in the claims.

In the accompanying drawings, Figure 1 is a side elevation of our improved machine for making creased or ornamented leather edgings and the like, parts being broken out. Fig. 2 is a vertical longitudinal section of the same;
35 Fig. 3, a vertical transverse section on line *x x*, Fig. 2; and Fig. 4, a plan view of the same.

Similar letters of reference indicate corresponding parts.

Referring to the drawings, A represents a
40 supporting-frame on which the different rolls composing our improved machine for making leather edgings are supported.

At the front end of the frame A is arranged a feed-table, B, which is provided with ways B',
45 for guiding the leather that is to be transformed into edgings toward a pair of feed-rolls, C C, by which the leather is fed to a pair of cutting-rolls, D D', which are constructed of a number of circular cutting-knives and intermediate ring-shaped sleeves or collars of suitable width, according to the width of the ed-

gings to be made. When narrow edgings have to be made, a larger number of cutting-knives are arranged on the shaft of the cutting-rolls and intermediate sleeves or collars of smaller
55 width are provided, while when wider edgings are to be made a smaller number of cutting-knives and wider sleeves or collars are employed. The circular cutting-knives and intermediate sleeves are tightly secured between a shoulder, *m*, on one end of the shaft
60 of each roll and a screw-nut, *m'*, at the other end, whereby the circular knives and intermediate sleeves are firmly pressed together. The lower roll, D, is supported in stationary bearings of the supporting-frame A, while the
65 upper cutter-roll, D', is supported in vertical adjustable bearings D², that are guided on ways of the vertical standards D³, which are provided with slots *d* for the clamping-screws
70 *d'*, by which the bearings D² can be set higher or lower on the standards D³, as shown clearly in Fig. 2. The shaft of the upper cutter-roll, D', is also laterally adjustable in its bearings,
75 so that its cutting-knives press tightly against the cutting-knives of the lower roll, the lateral adjustment being accomplished by a set-screw, D⁴, that bears against one end of the shaft of the upper cutter-roll, the set-screw
80 turning in a short side standard, *e'*, attached to the frame *a*. The lateral and vertical adjustment of the upper cutter-roll, D', is required for the purpose of providing for the wearing off of the cutting-knives, as well as of
85 the tight contact of the cutting-knives of the upper and lower rolls, so that the proper shearing action is exerted on the leather passed through between the cutter-rolls. The leather is cut by the cutter-rolls D D' in a series of
90 strips, which are conveyed through a series of folders, E, that are applied to a detachable plate, E', having a downwardly-bent front edge, E², said folders being interchangeable, according to the different widths of the strips cut by the cutter-rolls. Back of the folders E
95 is arranged a pair of feed-rolls, F F', and back of the feed-rolls the creasing or embossing rolls G G', of which one turns in stationary bearings of the supporting-frame A, while the other turns in vertical adjustable and spring-
100 pressed bearings guided in suitable upright standards attached to the main frame A. The

creasing-rolls are, like the cutter-rolls, composed of a number of circular creasing-knives and a series of intermediate sleeves, which are mounted on shafts of the creasing-rolls and secured by a screw-nut at one end of the same in the same manner as the cutter-rolls, the distance of the creasing-knives being determined by the width of the folded strips and the distance of the creases to be pressed into said strips. If the folded leather strips or edgings are to be embossed or otherwise ornamented, embossing-rolls are used in place of the creasing-rolls, said embossing-rolls imparting the required ornamental design to the faces of the edging. The feed-rolls C C' and F F', as well as the cutter-rolls DD' and the creasing or embossing rolls G G', receive rotary motion by a train of gearing from a driving-shaft having a fly-wheel and a crank, (shown clearly in Fig. 1,) whereby a forward motion in the same direction is imparted first to the leather, then to the folding-strips, and finally to the folded edgings, so that the same pass in longitudinal direction through the machine and are properly cut, folded, and ornamented by the same.

Having thus described our invention, we claim as new and desire to secure by Letters Patent—

1. The combination, substantially as herein described, of a pair of feed-rolls, a pair of cutter-rolls provided with circular cutting-

knives, a series of folders, a second pair of feed-rolls, and a pair of creasing or ornamenting rolls.

2. The combination, substantially as herein described, with a feed-table, of a pair of feed-rolls, a pair of cutter-rolls, a series of folders arranged beyond said cutter-rolls, a second pair of feed-rolls beyond the folders, and a pair of creasing or ornamenting rolls.

3. In a machine for making leather edgings, the combination of the lower cutter-roll having circular cutting-knives, the upper cutter-roll having circular cutting-knives arranged in contact with the cutting-knives of the lower roll, vertically-adjustable bearings for said upper roll, slotted supporting-standards for adjusting said bearings, clamp-screws for said bearings, and a stationary set-screw bearing against the end of the upper cutter-roll for adjusting the knives of the same laterally toward the knives of the lower cutter-roll, substantially as herein shown and described.

In testimony that we claim the foregoing as our invention we have signed our names in presence of two subscribing witnesses.

JOHN J. DALEY.
GEO. J. DALEY.

Witnesses:

M. PIANKO,
JOHN A. STRALEY.