



INTERNATIONAL APPLICATION PUBLISHED UNDER THE PATENT COOPERATION TREATY (PCT)

<p>(51) International Patent Classification ⁷ : G06F 17/60</p>	<p>A2</p>	<p>(11) International Publication Number: WO 00/46718 (43) International Publication Date: 10 August 2000 (10.08.00)</p>
--------------------------------------------------------------------------------------	------------------	-------------------------------------------------------------------------------------------------------------------------------------

<p>(21) International Application Number: PCT/US00/02888 (22) International Filing Date: 2 February 2000 (02.02.00) (30) Priority Data: 60/118,477 3 February 1999 (03.02.99) US 09/493,823 28 January 2000 (28.01.00) US (71) Applicant: FREIGHTMART.COM CORPORATION [US/US]; Suite 636, 100 North Brand Boulevard, Glendale, CA 91203 (US). (72) Inventor: TANGKILISAN, Christopher, Y.; Freightmart.com Corporation, P.O. Box 91338, Los Angeles, CA 90009-1338 (US). (74) Agents: FAR-HADIAN, F., Jason et al.; Loeb & Loeb LLP, Suite 2200, 10100 Santa Monica Boulevard, Los Angeles, CA 90067 (US).</p>	<p>(81) Designated States: AE, AL, AM, AT, AU, AZ, BA, BB, BG, BR, BY, CA, CH, CN, CR, CU, CZ, DE, DK, DM, EE, ES, FI, GB, GD, GE, GH, GM, HR, HU, ID, IL, IN, IS, JP, KE, KG, KP, KR, KZ, LC, LK, LR, LS, LT, LU, LV, MA, MD, MG, MK, MN, MW, MX, NO, NZ, PL, PT, RO, RU, SD, SE, SG, SI, SK, SL, TJ, TM, TR, TT, TZ, UA, UG, UZ, VN, YU, ZA, ZW, ARIPO patent (GH, GM, KE, LS, MW, SD, SL, SZ, TZ, UG, ZW), Eurasian patent (AM, AZ, BY, KG, KZ, MD, RU, TJ, TM), European patent (AT, BE, CH, CY, DE, DK, ES, FI, FR, GB, GR, IE, IT, LU, MC, NL, PT, SE), OAPI patent (BF, BJ, CF, CG, CI, CM, GA, GN, GW, ML, MR, NE, SN, TD, TG). Published <i>Without international search report and to be republished upon receipt of that report.</i></p>
------------------------------------------------------------------------------------------------------------------------------------------------------------------------------------------------------------------------------------------------------------------------------------------------------------------------------------------------------------------------------------------------------------------------------------------------------------------------------------------------------------------------------------------------------------------------------------------------------------------------------------------------	-------------------------------------------------------------------------------------------------------------------------------------------------------------------------------------------------------------------------------------------------------------------------------------------------------------------------------------------------------------------------------------------------------------------------------------------------------------------------------------------------------------------------------------------------------------------------------------------------------------------------------------------------------------------------------------------------------------------------------------------------------------------------

(54) Title: A METHOD AND APPARATUS FOR HANDLING SHIPPING REQUESTS VIA THE INTERNET

(57) Abstract

The invention is directed to a method of handling shipping orders over the Internet. In one or more embodiments of the invention, a shipper provides the necessary shipment information to numerous forwarders by providing the information only once to a service provider. The provided information is then maintained in the service provider's information storage system. The information is provided to a plurality of forwarders. The forwarders are invited to place their bids by a certain deadline. The system queries forwarders to place their bids and enter all relevant information that may be useful to the shipper in making a selection. The placed bids and information are then collected, stored, and arranged by the system for submission to the shipper. Certain information, such as survey results, news articles, or other publications including detailed information about the background of various forwarders that have participated in the bidding process, can also be made available to a shipper, if requested. Once the collected information is submitted to a shipper, he or she has the opportunity to select from the multiple bids provided by the system. Once the shipper accepts a bid, the transaction is completed and a confirmation is forwarded to the forwarder who has won the bid.

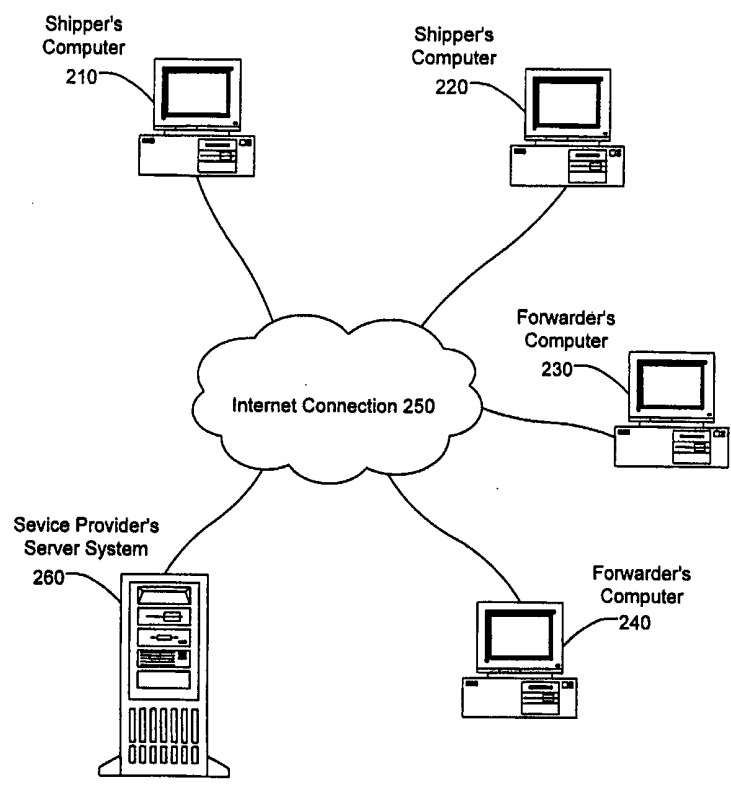

FOR THE PURPOSES OF INFORMATION ONLY

Codes used to identify States party to the PCT on the front pages of pamphlets publishing international applications under the PCT.

AL	Albania	ES	Spain	LS	Lesotho	SI	Slovenia
AM	Armenia	FI	Finland	LT	Lithuania	SK	Slovakia
AT	Austria	FR	France	LU	Luxembourg	SN	Senegal
AU	Australia	GA	Gabon	LV	Latvia	SZ	Swaziland
AZ	Azerbaijan	GB	United Kingdom	MC	Monaco	TD	Chad
BA	Bosnia and Herzegovina	GE	Georgia	MD	Republic of Moldova	TG	Togo
BB	Barbados	GH	Ghana	MG	Madagascar	TJ	Tajikistan
BE	Belgium	GN	Guinea	MK	The former Yugoslav Republic of Macedonia	TM	Turkmenistan
BF	Burkina Faso	GR	Greece			TR	Turkey
BG	Bulgaria	HU	Hungary	ML	Mali	TT	Trinidad and Tobago
BJ	Benin	IE	Ireland	MN	Mongolia	UA	Ukraine
BR	Brazil	IL	Israel	MR	Mauritania	UG	Uganda
BY	Belarus	IS	Iceland	MW	Malawi	US	United States of America
CA	Canada	IT	Italy	MX	Mexico	UZ	Uzbekistan
CF	Central African Republic	JP	Japan	NE	Niger	VN	Viet Nam
CG	Congo	KE	Kenya	NL	Netherlands	YU	Yugoslavia
CH	Switzerland	KG	Kyrgyzstan	NO	Norway	ZW	Zimbabwe
CI	Côte d'Ivoire	KP	Democratic People's Republic of Korea	NZ	New Zealand		
CM	Cameroon			PL	Poland		
CN	China	KR	Republic of Korea	PT	Portugal		
CU	Cuba	KZ	Kazakstan	RO	Romania		
CZ	Czech Republic	LC	Saint Lucia	RU	Russian Federation		
DE	Germany	LI	Liechtenstein	SD	Sudan		
DK	Denmark	LK	Sri Lanka	SE	Sweden		
EE	Estonia	LR	Liberia	SG	Singapore		

A METHOD AND APPARATUS FOR HANDLING SHIPPING REQUESTS VIA THE INTERNET

BACKGROUND OF THE INVENTION

1. FIELD OF THE INVENTION

5 This invention relates to the field of interactive computer software and, more specifically, to a business model for handling shipping orders placed via the Internet.

Portions of this patent document contain material that is subject to copyright protection. These copyrights are hereby reserved to the applicant or assignees thereof. However, the applicant has no objection to the reproduction of the patent document or the content of the
10 disclosure provided below, as it is necessary for the purposes of filing, prosecuting, or publishing this application in the United States Patent and Trademark Office.

2. BACKGROUND ART

Shipping of goods traditionally requires contacting a delivery service to pick up and deliver the goods. Due to the time constraints associated with the timelines for the pickup and
15 delivery of goods, however, the process for arranging the shipping and handling of goods can be a tedious and time-consuming task. For example, time and energy will have to be spent to find and select the most reliable and competitive shipping companies in the locality. Thereafter, multiple telephone calls and conversations will be necessary to inquire about the availability of a specific shipping service (e.g., next-day, two-day, air, ground, express, or other type of delivery).
20 Further, the shipping rates, timelines, and other related factors such as minimum and maximum weight requirements and delivery distance will have to be considered. Once all the necessary information is gathered, then a shipping company will have to be selected and the parties will have to agree on the time and location of pickup and delivery and negotiate over the cost of service.

With the ever-increasing influence of computers and the Internet in our daily lives, some of the mechanics involved in the shipping and delivery of goods have been automated. Many shipping companies, such as Federal Express and United Postal Service, provide their clients with an automated way of routing or tracking the shipment of goods. Among other information, these courier services also provide rate and service information as well as means for scheduling dates and times for pickup and delivery on their web sites. Unfortunately, though, there are no services available that can provide a consumer with a plurality of delivery options and a method to select the least expensive or the most valuable service from among many service providers.

A model is needed that allows a consumer to choose the price and delivery options from among a group of providers. The currently available models are not fully capable of providing the consumer with multiple choices; neither are they capable of analyzing the needs of the consumer and providing the consumer with the most suitable option. This invention and its advantages and improvements over the prior art schemes will be better understood and appreciated by reviewing the following discussion of computer networks, the Internet, and traditional shipping models.

Computer Networks and the Internet

The Internet is a global computer network that provides the infrastructure for the World Wide Web or the WWW. The World Wide Web is a communication system that is composed of millions of files that contain links to other files stored on various connected computers networks. A computer network includes a group of computers or other devices linked together in a manner that promotes communication between them. A computer network may include resources such as printers, modems, and file servers. It may also include services such as electronic mail or file transfer. A computer network can be a small system that is physically connected by cables (a

local area network, or "LAN") or several separate networks that are connected together to form a larger network (a wide area network, or "WAN"), such as the Internet. Other types of networks include tel-com networks, intranets, extranets, wireless networks, or other networks over which electronic, digital, or analog data may be communicated.

5 FIG. 1 illustrates a computer network, wherein a client computer 110 communicates with a server system 130 via an Internet connection 150. A server system (also known as a host computer) provides information to requesting computers (also known as clients) on a network. When there are large numbers of clients, such as it is the case with the Internet, it becomes necessary to have more than one server computer system to handle the requests. An Internet
10 client accesses a host computer on the worldwide network via an Internet service provider. An Internet service provider is an organization that provides a client with access to the Internet via analog telephone lines, Integrated Services Digital Network (ISDN) lines, or other communication means. Various protocols, services, and tools have been implemented to allow a client to retrieve information from or communicate with another computer on the Internet.
15 Hypertext Transport Protocol (HTTP) is the standard protocol for communicating with an information server on the Internet. A protocol refers to a formal set of rules that must be followed in order for network computers to communicate. The HTTP protocol provides for communication methods that allow clients to request data from a server and send information to the server (e.g., downloading files or sending electronic mail).

20 One of the most valuable and commonly used tools for communication over the Internet is a software application known as the browser. Examples of the most popular browsers currently available include Netscape Navigator, Microsoft Internet Explorer, Mosaic and Cello. As illustrated in FIG. 1, a browser 120 is a software application that runs on a client computer

110 and provides a user-friendly environment in which a user can interact with computer 110 via a graphical user interface (GUI). A GUI allows the user to submit various requests or responses without having to learn or type complicated or unmemorable text commands. A browser requests, transfers, and displays information that is stored as files on the Internet.

5 Requests submitted by a client computer are processed by computer systems known as hosts or servers. A server that responds to a request over the Internet is generally known as an HTTP server. In a typical client-server communication, client computer 110 transmits a request to HTTP server 130 (e.g., GET an object from the server or POST data to an object on the server). The HTTP server 130 responds to the client computer 110's request by forwarding a
10 request status and the requested information.

 A client request is, typically, a request for access to a resource on the host computer. One of the most commonly accessed resources are web sites, or web pages. Web pages are interactive resources that provide a user with a graphical interface for either viewing or downloading information. An addressing scheme is employed to identify Internet web sites and
15 other available resources. This addressing scheme is called Uniform Resource Locator (URL). A URL is a string of characters that includes information about the location of a resource on the Internet, the type of service requested, and the method (i.e., protocol) of communicating with that resource. In the case of a web site, the URL includes the address of the server on the
Internet (i.e., the IP address), the port on which the server application is connected (i.e., the port
20 number), and the location of the web site in the file structure of the server (i.e., the domain name and HTML file name).

 A web site may include a number of graphically displayable pages of information (e.g., web pages) that are linked together. A concept known as hypertext or hyperlinks is used for

maneuvering and linking the multiple pages of a web site. A hypertext or a hyperlink provides the ability to move directly from one web page to another web page or to other information within the same page. To activate the link, it is only necessary to click on the hyperlink (e.g., a word or an icon on the web page). A URL associated with the link identifies the location of the additional information and the browser submits the URL information in a request to the server to access the data at the site specified in the URL.

When a server receives a URL request, it first locates the web page referenced in the URL and then forwards the content of the web page to the requesting client. Referring to FIG. 1, the contents of a web site can be created by using a computer language called the Hypertext Markup Language (HTML). This content are saved as HTML files 140 on the server. Other languages such as Extensible Markup Language (XML) and the like can be also used for creating web pages. An HTML document is a text file coded with predefined keywords (i.e., tags) and regions defined within those tags that allow a browser to identify and display different text or graphical information at a certain location on a web page. An example of the partial content of an HTML file is provided below.

```
<HTML>
  <HEAD>
    <TITLE>freightmart.com</TITLE>
    <SCRIPT LANGUAGE="JavaScript">
    <META NAME="keywords" CONTENT="shipping freight"
    function dosomething() {
      }
    ...
  </HEAD>
  <BODY>
    text and graphic information
    ...
  </BODY>
</HTML>
```

The words enclosed in between the "<" and ">" constitute a tag that identifies a region of

the HTML file. In the "HEAD" region, the title of the web page, java applets (for performing various functions), and other information about the web page may be defined. In the "BODY" region, all the text and other displayable information and the manner and location of their display on the web page are defined. A browser application that is executing on a client computer upon receiving an HTML file parses its content and graphically displays the page on the client's computer screen, based on the information in the HTML document. Once the client has viewed the web page, the client can submit another request to view another web page on the Internet, or may interact with the web page by entering information in a dialog box or clicking on a button, for example.

10 Traditional Shipping Models

Traditionally, computer networks have not been utilized to handle shipping orders over the Internet. Current shipping models for transferring freight from one point to another are demanding, time-consuming, and expensive, both for the shipping company and the shipper (i.e., the person who uses the services of a shipping company). Typically, a shipper who intends to ship a package from point A to point B wants to secure a competitive shipping rate. Thus, the shipper needs to contact several shipping companies and analyze their services based on their reputation, shipping rates, geographical coverage, and other related factors. Once the shipper has educated himself about all the particulars of the shipping service, then he can select the most feasible shipping service that fits his needs.

20 Similarly, shipping companies also need to spend valuable time and money on various methods of advertising and marketing to attract customers. In addition to their marketing overhead, each company needs to maintain a staff for taking customer orders and responding to customer telephone calls. Quality of customer service and the financial well-being of the

company are highly dependent on the successful and effective training of well-mannered customer service representatives. The cost of training competent customer service representatives can be very expensive.

5 Aside from the overhead costs, a shipping company's profit margin is highly dependent on the amount of shipping surplus. Shipping surplus is an effect that is created by shipping goods in less-than-full capacity cargo space. For example, the cost of shipping cargo in a cargo bin is the same whether the cargo bin is full or partially full. A shipping company has a higher profit margin if it can minimize its shipping surplus.

10 Unfortunately, the current shipping models do not provide the means for either the shipper or the shipping company to interact in such a way to minimize the above-mentioned losses in time and money. Traditionally, it has been easier for a shipper to establish a business relationship with a few shipping companies that provide him with reasonable shipping rates. However, this business model promotes dependency on a few shipping companies and does not provide the shipper with the most competitive bids that may be available in the market.

15 A shipping model is needed that can effectively deal with the above shortcomings so that the shipper would not have to waste time, money, and energy in researching and selecting a shipping company that most adequately satisfies his needs. It would be beneficial to both the shipper and the shipping company if means are available to efficiently handle shipping orders in a way to reduce the cost and overhead associated with the shipping process.

SUMMARY OF THE INVENTION

The invention is directed, in one or more embodiments, to a method of accepting, handling, and placing shipping orders and a shipping system that is available to a multitude of forwarders (i.e., shipping companies) and shippers (i.e., consumers with shipping needs) around the world. The objective of this invention is to provide a bidding environment for the forwarders so that a shipping company can view the specific details of a shipping order and place a bid for the specific order at the time. In one or more embodiments of the invention, the bids are to be placed by a certain deadline, as provided by the shipper.

In one or more embodiments of the invention, a shipper provides the necessary shipment information (e.g., origination location, destination, size of shipment, etc.) to numerous forwarders by providing the information only once to a service provider. A specific query site, such as a web site or a toll-free telephone line, is made available to the shipper by the service provider, where all the particulars and relevant information for a shipping order are collected. For example, a shipper can access a web page on the World Wide Web, wherein the shipper is queried for the needed information via specially designed dialogue and text boxes. The provided information is then maintained in the service provider's information storage system such as a relational data base, where the information can be reorganized and speedily retrieved and manipulated, based on various criteria such as the time the information was received, the urgency of shipment, and the identity of the shipper.

Once the information is appropriately organized and sorted, the shipping order including other relevant information are provided to available forwarders. Forwarders are shipping companies that have subscribed to the service to receive information about the shipping orders. In one or more embodiments of the invention, the forwarders are categorically selected. For

example, a shipping order may be provided only to a certain number of forwarders as elected by the shipper. Alternatively, forwarders may be selected based on other criteria, such as their geographical area, their business reputation, or their marketing arrangement with the service provider. For example, in one or more embodiments of the invention, forwarders can pay a premium subscription fee to the service provider so that they are notified earlier than the other forwarders, who pay lower or no subscription fees.

In some embodiments of the invention, forwarders after receiving a proposed shipping order are invited to place their bids by a certain deadline. The system queries forwarders to place their bids and enter all relevant information that may be useful to the shipper in making a selection. The placed bids and information are then collected, stored, and arranged by the system for submission to the shipper. Certain information, such as survey results, news articles, or other publications including detailed information about the background of various forwarders that have participated in the bidding process, can also be made available to a shipper, if requested. Once the collected information is submitted to a shipper, he or she has the opportunity to select from the multiple bids provided by the system. Before making a selection, a shipper can reference additional information available on the system to evaluate and identify a forwarder that best suits his or her shipping needs.

Embodiments of the invention help the shipper to save time and money by providing the shipper with multiple bids in a short window of time. The system also provides the shipper with helpful information about forwarders. Using the system, a shipper can be assured of getting a competitive shipping rate and has the opportunity to study the background of various forwarders before making a choice. Once the shipper accepts a bid, the transaction is completed and a confirmation is forwarded to the forwarder who has won the bid. Embodiments of the invention

also assist forwarders to be more efficient in running their business. Using the system, a forwarder can reduce its overhead costs associated with hiring and training customer service and operations staff. The system can be also used to potentially reduce the cost of marketing and advertising by allowing the forwarder to target groups of shippers who are categorically more suitable to use the services of the specific forwarder. The system can also be utilized to reduce shipping surplus and maximize revenue per shipment.

BRIEF DESCRIPTION OF THE DRAWINGS

FIG. 1 illustrates a computer network environment including a web server and a web client.

FIG. 2 illustrates a computer network environment, according to one or more
5 embodiments of the invention, where shippers and forwarders communicate with the service provider's server system via the Internet.

FIG. 3A is a block diagram of one embodiment of a computer system capable of providing a suitable execution environment for one or more embodiments of the invention.

FIG. 3B is a block diagram of one embodiment of system software that directs the
10 operation of the computer system illustrated in FIG. 3A.

FIG. 4 is a flow diagram of a method of handling shipping orders placed over the Internet using the system of this invention, according to one or more embodiments.

FIG. 5 is a flow diagram of a method of collecting shipping information, according to one or more embodiments of the invention.

15 FIG. 6 is a flow diagram of a method of processing shipping orders, according to one or more embodiments of the invention.

DETAILED DESCRIPTION OF THE INVENTION

The invention is directed to a method and apparatus for handling shipping orders on the Internet and a system that provides a shipper with the best possible bid from among a number of bids submitted by forwarders. In a certain preferred embodiment of the invention, the shipping system and their services provided by the system are managed, maintained, and operated by a service provider.

The service provider is an entity to which both the shippers and the forwarders subscribe. A shipper is a person or an entity who places a shipping order. A forwarder is a person or an entity such as a shipping company or courier service that submits a bid for providing the shipping service.

In the following description, numerous specific details are set forth to provide a more thorough description of embodiments of the invention. It is apparent, however, to one skilled in the art that the invention may be practiced without these specific details. In some instances, well-known features have not been described in detail so as not to obscure the invention.

System Architecture

In one or more embodiments of the invention, a computer system architecture is utilized to accept and process shipping orders and bids submitted by multiple shippers and forwarders, and to handle the communication of all information among the shippers, forwarders, and other parties involved in the process. Typically, a computer system architecture is composed of two distinct environments, a software environment and a hardware environment. The hardware environment, as it is discussed in further detail below, includes the machinery and equipment (e.g., CPU, disks, tapes, modem, cables, etc.) that provide an execution environment for the

software. On the other hand, the software environment provides the execution instructions for the hardware environment.

In operation, a computer needs both the hardware and the software environments to function. One is useless without the other. The software environment can be divided into two major categories, including system software and application software. As it is further discussed below, system software is made up of control programs, such as the operating system (OS) and information management systems, that instruct the hardware how to function and process information. Application software is a program that more directly interact with a user and processes specific information for a user (e.g., word-processing applications). In short, the hardware environment specifies the commands it can follow and the software environment instructs it what to do.

FIG. 2 illustrates the system architecture according to one or more embodiments of the current invention, where shippers and forwarders communicate with a service provider via the Internet using client computers. The service provider is the entity that provides the shippers and forwarders with the on-line services that are the subject matter of the current invention. In one or more embodiments of the invention, the system software and the application software that implement the on-line shipping services are at least partially installed on one or more server systems, such as service provider's server system 260.

The services are available via Internet connection 250 to shippers or forwarders who have established an account with the service provider. Internet connection 250 connects client computers utilized by the shippers and forwarders (e.g., computers 210 through 240) to service provider's server system 260. Computers 210, 220, 230 and 240 are utilized by the shippers or the forwarders to post or receive shipping orders and bidding information from server system

260. The client and server computer systems, in one or more embodiments of the invention, include hardware and software components and system architectures that are suitable for the operation of the application software of this invention.

The various hardware and software components of the above client and server architectures are illustrated in FIGS. 3A and 3B. This invention, including the application software for handling shipping orders on the Internet, in one or more embodiments, can be implemented in association with hardware system 310 (FIG. 3A) and software system 320 (FIG. 3B) as described in further detail below. The following hardware and software systems, however, are provided for the purpose of example only. The invention may be practiced either individually or in combination with other suitable hardware or software architectures or environments.

System Hardware Environment

An embodiment of the invention that includes the system and application software can be implemented as computer software in the form of computer readable code executed on a general purpose system such as system 310, illustrated in FIG. 3A. System 310 comprises a central processor unit 301, a main memory 302, an input/output controller 303, cache memory 304, user interface devices 305 (e.g., keyboard, mouse, microphone, camera, etc.), storage media 306 (e.g., hard drive, flash memory, floppy, optical, or magneto-optical disks, etc.), a display screen 307, and a communication interface 308 (e.g., a network card, a modem, or an integrated services digital network (ISDN) card, etc.), and a system clock (not shown in FIG. 3A).

Processor 301 may or may not include cache memory 304 that is utilized for storing frequently accessed information. One or more input/output devices such as a printing or a scanning device may be included in system 310. A communication means, such as a bi-

directional system bus 300, is utilized to provide a mechanism for communication between the system components. The system itself is capable of communicating with other systems through communication interface 308.

For example, system 310 can send messages and receive data, including program code
5 through the communication interface 308. Wireless links are also possible. In any such implementation, communication interface 308 can send and receive electrical, electromagnetic or optical signals which carry digital data streams representing various types of information. If communication is established via the Internet, a remote server system might transmit the requested code for an application program through an Internet connection to the communication
10 interface 308. The received code is executed by central processor unit 301 as it is received or is stored in storage media 306 or other non-volatile storage for later execution.

System 310 may obtain program code in any form, for example in the form of code transmitted via any type of carrier wave. Program code may be embodied in any form of computer program product. A computer program product comprises a medium configured to
15 store or transport computer readable code, or a medium in which computer readable code may be embedded. Some examples of computer program products are CD-ROM disks, ROM cards, floppy disks, magnetic tapes, computer hard drives, servers on a network, and carrier waves.

In one or more embodiments of the invention, processor 301 is a microprocessor manufactured by Motorola or a microprocessor manufactured by Intel, such as a Pentium
20 processor, or a SPARC microprocessor from Sun Microsystems, Inc. The named processors are for the purpose of example only. Any other suitable microprocessor or microcomputer may be utilized. The system hardware environment may be embodied in the form of a computer system, a set-top box, or other similar hardware environments that have information processing and data

storage capabilities.

System Software Environment

FIG. 3B illustrates a computer software system 320 suited for managing and directing the operation of system 310, for example. System software 320 is, typically, stored in storage media 5 306 and is loaded into memory 302 prior to execution. It includes an operating system (OS) 321 that controls the low level operations of system 310. Low level operations include the management of the system's resources such as memory allocation, file swapping, and other core computing tasks. In one or more embodiments of the invention, operating system 321 is Microsoft Windows 98, or Microsoft Windows NT, or Macintosh OS, or IBM OS/2. However, 10 any other suitable operating system may be utilized.

One or more computer programs, such as client software application 322, are executed on top of the operating system 321 after they are loaded from storage media 306 into memory 302. Client software application 322 may include a web browser software 323 for communicating with the Internet. Software system 320 includes a user interface 324 (e.g., a Graphical User 15 Interface (GUI)) for receiving user commands and data. The commands and data received are processed by the software applications that are running on the computer system 310.

The system architectures and environments described above are for purposes of example only. Embodiments of the invention may be implemented in any type of system architecture or processing environment. For example, in some embodiments of the invention the system 20 software may be hardwired into the hardware environment or implemented within non-volatile memory devices.

Application Software for a Shipping Business Model

One or more embodiments of the invention are directed to a method and apparatus for

collecting and processing shipping information via the Internet. Referring to FIG. 2, shippers may place shipping orders using computer equipment, such as computers 210 and 220.

Forwarders, in turn, can view the shipping orders placed by the shippers using computer equipment, such as computers 230 and 240. Computers 210, 220, 230, and 240 may be located
5 at any location, whether at home or business premises.

As illustrated in FIG. 2, one or more of the computers used for the purposes of placing or viewing a shipping order are connected via Internet connection 250 in a worldwide network. A server system, such as service provider's server system 260, is utilized to provide the hardware and software execution environment for the application software of the current invention. The
10 application software is executed partly or fully on server system 260 or client computers 210 through 240, for example.

Server system 260 is the unit that controls, manages, and directs data communication between the shippers and the forwarders. Server system 260 may include one or more server computers and other resources that are necessary to provide communication and data
15 management services for the entire shipping system. A shipper who desires to ship a package or cargo using the system of this invention will use a computer connected to the Internet to locate the registration web site for the service provider. Once at the site, the shipper registers as a member by providing certain identifying information. In exchange he receives a login ID and password, for example. In some embodiments of the invention, the registration process can be
20 completed via other means, for example, by calling into a registration center.

Once the shipper has completed registration, the shipper can place a shipping order by logging on to the service provider's shipping site and entering the necessary information, such as size and weight of the shipment or the pickup and delivery dates and times. FIG. 4 is a flow

diagram of a method of handling shipping orders placed over the Internet using the system of this invention, according to one or more embodiments. At step 410, a shipping order is received from the shipper. At step 420, the shipping order is processed by the system. The information submitted by the shipper is stored, analyzed, and manipulated to determine or solicit the most competitive shipping bids available for a particular shipping order. The results are provided to the shipper, at step 430, in the form of one or more possible bids. At step 440, the shipper selects a bid from among the available options. At step 450, the forwarder who has won the bid is notified. The detailed account of the steps involved in placing an order and the method of processing the order are described in FIGS. 5 and 6 and are discussed in further detail below.

Collecting Shipping Orders

In a particularly preferred embodiment of the invention, shipping orders are collected in a series of steps. Referring to FIGS. 1 and 2, in order for the shipper to input the necessary information, the shipper first establishes an Internet connection 250 with the service provider's server system 260 using a client computer (e.g., shipper's computer 210). Connection 250 is established via a socket, which is a mechanism for establishing a virtual connection between software applications running on a server computer and the client computer in a network.

Once the connection is established the shipper can view the service provider's Internet site using browser 120. Browser 120 is a software application that runs on client computer 210. To display a web site, the browser issues an HTTP GET request referencing a URL for the web site the consumer desires to view (e.g., www.freightmart.com). Server system (HTTP server) 260 receives the request transmitted over the Internet connection 250 and searches its file system for the HTML files referenced in the submitted URL. If HTML files are located, server 260 responds to the client 210's request by forwarding one or more of the HTML files. Upon receipt

the browser parses HTML files and displays the host's web page on the client computer 210's screen.

In a preferred embodiment of the invention, the system requests a shipper to enter a verifiable user ID and a password before allowing access to the content of the web page. FIG. 5 is a flow diagram of a method of collecting shipping information, wherein a shipper can log on to the service provider's web site at step 510 by entering his or her user ID and password. The service provider's web site contains a graphic user interface or other interface means, such as voice-activated interface, for example, that allows the shipper to provide the necessary shipping information. The web site may solicit from the shipper various kinds of shipping information, such as inquiries related to the size and weight of the shipment, or pickup and delivery hours or methods.

In an embodiment of the invention, the shipper provides the requested information to the system in steps 520 through 550, either by typing them within specifically provided text boxes, for example, or other suitable interface methods. At step 520, the shipper provides shipping information regarding the size, weight, or other configurations of the shipment. Other shipping configuration can relate to or define the class, kind, content, or the number of pieces included in a shipment. For example, the shipper can provide the number of pallets being shipped, the class defining the density of goods (e.g., foam is class 250), the content characteristics (e.g., electrical, frozen foods, fragile, etc.), or the kind of goods defining whether the goods are dangerous, flammable, or general commodity.

At step 530, the shipper provides the pickup date and time for the shipment. The shipper may also provide alternate dates and times to broaden the pickup possibilities as permissible. For example, the shipper may provide either an exact date and time (e.g., January 1, 2000 at 2:00

p.m.), more than one exact date and time, or a pickup time period (e.g., January 1, 2000, between 2:00 and 3:00 p.m.). The information can be either entered in text format or by selecting various graphical user interface methods, such as drop-down menus, radio buttons, or other interface mechanisms that allow a user to select from a range of items. In one or more embodiments of the invention, the shipper can set a deadline before which the forwarder can submit bids for consideration. For example, a shipper that wants to have a shipment forward on January 1, 2000 may want to have a bid closing date of December 30, 1999 at 12:00 p.m.

At step 540, the shipper provides a preferred method of delivery, including one or more alternatives. For example, a shipper may elect for the cargo to be transported by ocean container, truck loads, or train. Additionally, a shipper can also select the type of service, such as overnight delivery, two-day delivery, or other methods of delivery (e.g., air, ocean, ground, etc.). Once the shipper has entered all the necessary information, he may be prompted to review the information and confirm it by clicking on a submit button, for example. At step 560, the shipper requests that the result of the inquiry to be selected automatically by the system or based on a specific selection criteria as provided by the shipper. For example, the shipper may elect for the system to automatically provide the shipper with the name and information of the forwarder that can least expensively handle the shipment. Alternatively, the shipper may elect to receive information about two or more forwarders that have submitted the most competitive bids.

In a certain preferred embodiment of the invention, the shipper can select one or more specific forwarders and invite them to bid on a specific order. Alternatively, the shipper can specifically request the system to select only certain forwarders' bids, rather than automatically selecting the most competitive bids. This feature of the invention allows a shipper to promote his or her business with those forwarders with whom he or she has previously established a

relationship. This feature is also useful when the shipper wants to select only those forwarders who are more attractive to the shipper than the others, for example, because of the forwarder's good business reputation or specialty services. Thus, a shipper can select a single forwarder or a group of forwarders to be notified of a specific bid in exclusion of other forwarders.

5 Alternatively, the bid can be submitted to all forwarders, but a group of forwarders can be selected to be solicited for their bids by additional means such as direct e-mail messaging.

In an embodiment of the invention, for example, a shipper can place a shipping order with a specific request for a certain closing deadline (e.g., January 1, 2000 at 1:00 p.m.). The shipper may then elect to invite one or more specific shippers to submit a bid for that specific
10 order by notifying them via an e-mail message or other methods of the bid's identification number. In some embodiments, the shipper can provide specific forwarders with an extended bidding deadline, so that they can enter a more competitive bid than the ones already submitted. In embodiments of the invention, the bidding can be either closed or open. In an open bidding system, all bidders are able to see the bids submitted by others. In a closed bidding system, the
15 bidders cannot view the bids submitted by others and are therefore required to submit blind bids. Thus, in a preferred embodiment of the invention where an open bidding system is used, an invited forwarder can view the bids of other forwarders after the general bidding period is over and submit a more competitive bid during the extended bidding deadline.

Once all the necessary information for the shipping order is provided by the shipper, in a
20 specific embodiment of the invention, at step 570 the shipper is prompted to select a method of payment (e.g., credit card, check, COD, etc.). The shipper then selects a payment method. At step 580, the shipper reviews and confirms the shipping order and submits the order by clicking on a submit button, for example. The collected information is stored temporarily in shipper's

computer 210 and later transmitted to service provider's server system for processing and analysis via Internet connection 250.

The shipping information is collected by means of various input interfaces that appear on the system's web page. Navigation from one page to the next page of the web site is made possible by clicking on the hyperlinks on each web page, for example. A hyperlink is associated with a URL that references the location of the HTML file that includes information about the next page of the web site. Once that HTML file is obtained and parsed by the browser, the next web page is displayed. Each web page contains various interactive graphical user interface mechanisms, such as text boxes, checkboxes, and radio buttons, that are used in various ways to gather input information and to provide interactivity between a user and the system. The interactive graphical user interfaces described here are by way of example only. Other suitable interface designs or methods may be utilized for collection of information from a shipper or forwarder.

Processing Shipping Orders

In one or more embodiments of the invention, information submitted by a shipper is collected by computer 210 and transmitted via Internet connection 250 to service provider's server system 260 for processing. The collected information is disseminated in the form of encapsulated packets of data over the Internet. Data is packetized according to a set of standards (i.e., protocols) and is sent to server system 260 based on special addressing schemes, as described earlier. Once data packets are received at server system 260, the data is reassembled (i.e., depacketized) and stored in a storage medium.

Referring to FIG. 6, the collected information is analyzed at step 610 for various purposes. For example, the data is verified to ensure authenticity of information (e.g., credit card

numbers, User ID, password, etc.). The submitted order information may also be analyzed for accuracy. For example, the system will verify submitted information to ensure that all proper and necessary fields (e.g., pickup time and date, bid closing date, delivery pickup and destination addresses, etc.) are accurately and completely provided. The data may also be analyzed for other
5 purposes, such as for collecting and maintaining a consumer profile data base.

In one or more embodiments of the invention, at step 620 the system selects one or more forwarders that can manage the submitted shipping order by taking one or both of the following steps. At step 630, the collected shipping information is sent to all or a selected group of forwarders, based on the information provided by the shipper. The information is, in one or
10 more embodiments, either partially or fully accessible by all forwarders who have access to the on-line shipping system of the invention. To access the system, a forwarder needs to register as a member by providing certain identifying information and receiving a login ID and password, for example. In some embodiments of the invention, a forwarder may be given an option to subscribe to a type of service by paying a subscription fee.

15 Once the forwarder has completed the registration process, the forwarder can view the shipping orders submitted by various shippers, for example, by referencing an order ID. Depending on the options selected by the shipper and other factors (e.g., the subscription policy of the service), all or only a few of the submitted orders may be available for viewing by a certain forwarder. For example, in a specific embodiment of the invention, a forwarder that pays
20 a premium membership fee may be able to view certain bids earlier than other forwarders, or in some embodiments a forwarder may be limited to view shipping orders in a certain geographic area only, based on the type of his or her subscription agreement or location of the forwarder's or the shipper's business. Other related factors may also be considered to implement various

viewing capabilities for a forwarder.

After viewing a shipping order, a forwarder has the option to submit a bid using a computer terminal such as forwarder's computer 230. The bid and all other relevant information submitted with the bid (e.g., forwarders requirements for pickup and delivery, or other shipping particulars) are received at step 640 by service provider's server system 260 via Internet connection 250. In addition to the above methods, bidding information can also be collected by accessing bid information stored in a database, at step 635. In embodiments of the invention, instead of soliciting a forwarder to submit a bid for each shipping order, the system can be configured to automatically examine previously submitted bids or shipping rates for a shipment category that matches that of the submitted order.

In one or more embodiments of the invention, for example, forwarders provide a price schedule for various shipping options in advance. This information is stored in a database and is accessible by the service provider's server system 260. Thus, when a shipping order is submitted by a shipper, the system can automatically retrieve the stored bid information from the data base, at step 645. Once the bidding information for a specific shipping order is received from the forwarders or is retrieved from the database, then the system provides the shipper who placed that order with one or more bids, depending on system configurations.

In a certain preferred embodiment of the invention, at step 650 the system analyzes the submitted bids and determines one or more of the lowest bids. Depending on system configurations and the terms of the shipper's or the forwarder's subscription agreement, bid information is formatted for delivery to the shipper, at step 660. In certain embodiments of the invention, only the lowest bid is provided to a shipper. In other embodiments, the system may be configured to provide a shipper with the top five most competitive bids, for example. Yet in

other embodiments of the invention, the system may be configured to provide bids from a specific group of forwarders in exclusion of all others. For example, a shipper may have elected to accept bids only from a specific group of forwarders, as earlier discussed.

In other embodiments of the invention, bid information or the order in which bids are displayed to a shipper may be influenced by the terms of a forwarder's subscription agreement. For example, the bid information of a forwarder who pays a premium for his subscription may be displayed at a special place on the display (e.g., the very first line in the list of displayed bids). In some embodiments, only the bid prices are displayed and the identity of the forwarder is not revealed unless the shipper accepts the forwarder's bid. In other embodiments, the identity of the forwarder may be displayed so that the shipper can research the background of the forwarder before accepting its bid.

Once the bid is accepted by the shipper, the forwarder who has won the bid is notified and the necessary information about the identity of the shipper and other shipping information are provided to the forwarder for the transaction to be completed. In one or more embodiments of the invention, the shipper may submit a price along with the order information to reverse auction his shipping order. In this embodiment, a forwarder who accepts to handle the order for the submitted price will be notified that he has won the bid.

Thus, an on-line shipping model wherein both forwarders and shippers can easily and efficiently place their orders and bids is described in conjunction with one or more specific embodiments. The invention is defined by the claims and their full scope of equivalents.

CLAIMS

What is claimed is:

1. A method for handling shipping orders between shippers and forwarder, said method comprising:
 - a shipper placing a shipping order;
 - providing one or more forwarders with the shipping order;
 - one or more forwarders placing a bid for the shipping order;
 - providing the shipper with one or more bids submitted by said one or more forwarders;and
the shipper selecting one of the bids placed by a forwarder.
2. The method of claim 1, further comprising the step of notifying the forwarder whose bid the shipper has selected.
3. The method of claim 2, wherein the shipping order includes information regarding physical characteristics of an item being shipped.
4. The method of claim 3, wherein the shipping order includes information regarding a time for picking up the item.
5. The method of claim 4, wherein the shipping order includes information regarding a time for delivering the item.
6. The method of claim 5, wherein the shipping order includes information regarding

a preferred method of delivery of the item.

7. A method for handling shipping orders between shippers and forwarder, said method comprising:

a shipper placing a shipping order including shipping information;
processing the shipping information; and
selecting one or more forwarders based on the result produced by the processing step.

8. The method of claim 7, further comprising:
providing one or more of the selected forwarders with the shipping information;
one or more forwarders placing a bid for the shipping order; and
providing the shipper with one or more bids submitted by said one or more forwarders.

9. The method of claim 7, further comprising:
retrieving shipment price information for the selected forwarders from a pre-existing data base; and
providing the shipper with one or more bids based on the retrieved price information.

10. The method of claims 8 or 9, wherein the shipper is provided with one or more of the most competitive bids placed for the shipping order.

11. A method for handling shipping orders between shippers and forwarder, said method comprising:

a shipper placing a shipping order including shipping information;
providing one or more forwarders with the shipping information and a first bidding deadline; and
inviting one or more specific forwarders to bid on the shipping order before a second bidding deadline.

12. The method of claim 11, wherein the second bidding deadline is later than the first bidding deadline.

13. The method of claim 12 further comprising:
providing the shipper with one or more bids submitted by said one or more specific forwarders;
providing the shipper with one or more bids submitted by forwarders other than the specific forwarders, if no bids are submitted by the specific forwarders.

14. A shipping system, comprising:
a first system for placing a shipping order by a shipper;
a second system connected to said first system for receiving the shipping order from the first system and for displaying the shipping order to one or more forwarders; said second system capable of accepting and forwarding bids placed by said one or more forwarders to said first system for viewing and selection by the shipper.

15. The shipping system of claim 14, wherein said first and second systems

communicate via the internet.

16. The shipping system of claim 15 further comprising a server system connected to the internet for processing information communicated between the first and second systems.

17. The shipping system of claim 16, wherein the shipping order is provided to a selected group of forwarders based on information included in the shipping order.

18. The shipping system of claim 17, wherein one or more selected forwarders place a bid for the shipping order; said shipping bids being provided to the shipper for selection.

19. The shipping system of claim 17, wherein one or more bids are provided to the shipper based on pre-existing price information stored in a data base.

20. The shipping system of claims 18 or 19, wherein the shipper is provided with one or more of the most competitive bids available for the placed shipping order.

21. The shipping system of claim 17, wherein the information included in the shipping order sets a first bidding deadline.

22. The shipping system of claim 21, wherein one or more specific forwarders are invited to bid on the shipping order before a second bidding deadline.

23. The shipping system of claim 22, wherein the second bidding deadline is later than the first bidding deadline.

24. A computer program product comprising:
a computer usable medium having computer readable program code embodied therein configured to handle shipping orders between shippers and forwarders comprising:
computer readable code configured to cause a computer to accept a shipping order placed by a shipper;
computer readable code configured to cause a computer to provide one or more forwarders with the shipping order;
computer readable code configured to cause a computer to accept a bid from said one or more forwarders for the shipping order; and
computer readable code configured to cause a computer to provide a shipper with one or more bids submitted by said one or more forwarder.

25. The computer program product of claim 24 further comprising computer readable code configured to cause a computer to select one of the bids placed by a forwarder as requested by the shipper.

26. The computer program product of claim 25 further comprising computer readable code configured to cause a computer to notify the forwarder whose bid the shipper has selected.

27. The computer program product of claim 24, wherein the computer readable code is configured to provide the shipper with the most competitive bid.

28. The computer program product of claim 24, wherein the computer readable code is configured to provide the shipper with one or more bids based on pre-existing shipping price information stored in a database.

29. The computer program product of claim 24, wherein the shipping order includes a first bidding deadline; said computer readable code configured to accept bids submitted by said one or more forwarders before the expiration of the first deadline.

30. The computer program product of claim 29 further comprising computer readable code configured to invite a selected group of forwarders to bid on the shipping order before a second shipping deadline expires.

31. A business shipping model for placing shipping orders between shippers and forwarder, comprising the steps of:

- a shipper inputting into a computer a conditional purchase offer which includes an offer price;
- outputting the conditional purchase offer to a plurality of forwarders; and
- inputting into the computer an acceptance from a forwarder, the acceptance being responsive to the conditional purchase offer.

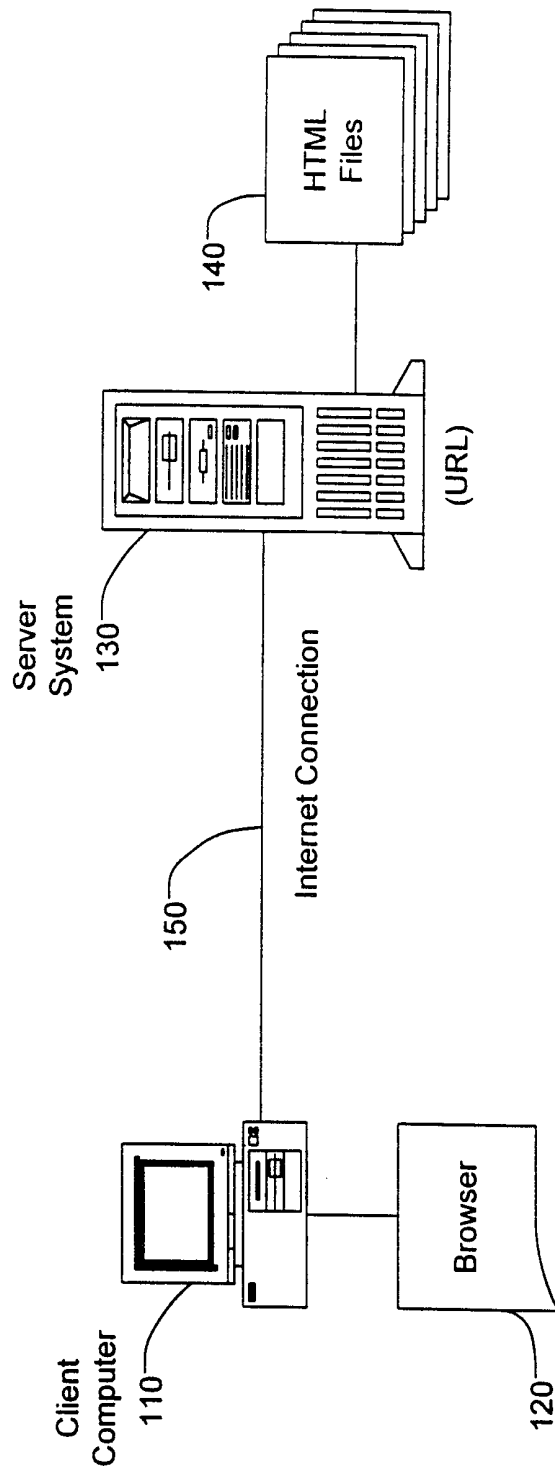

FIG. 1

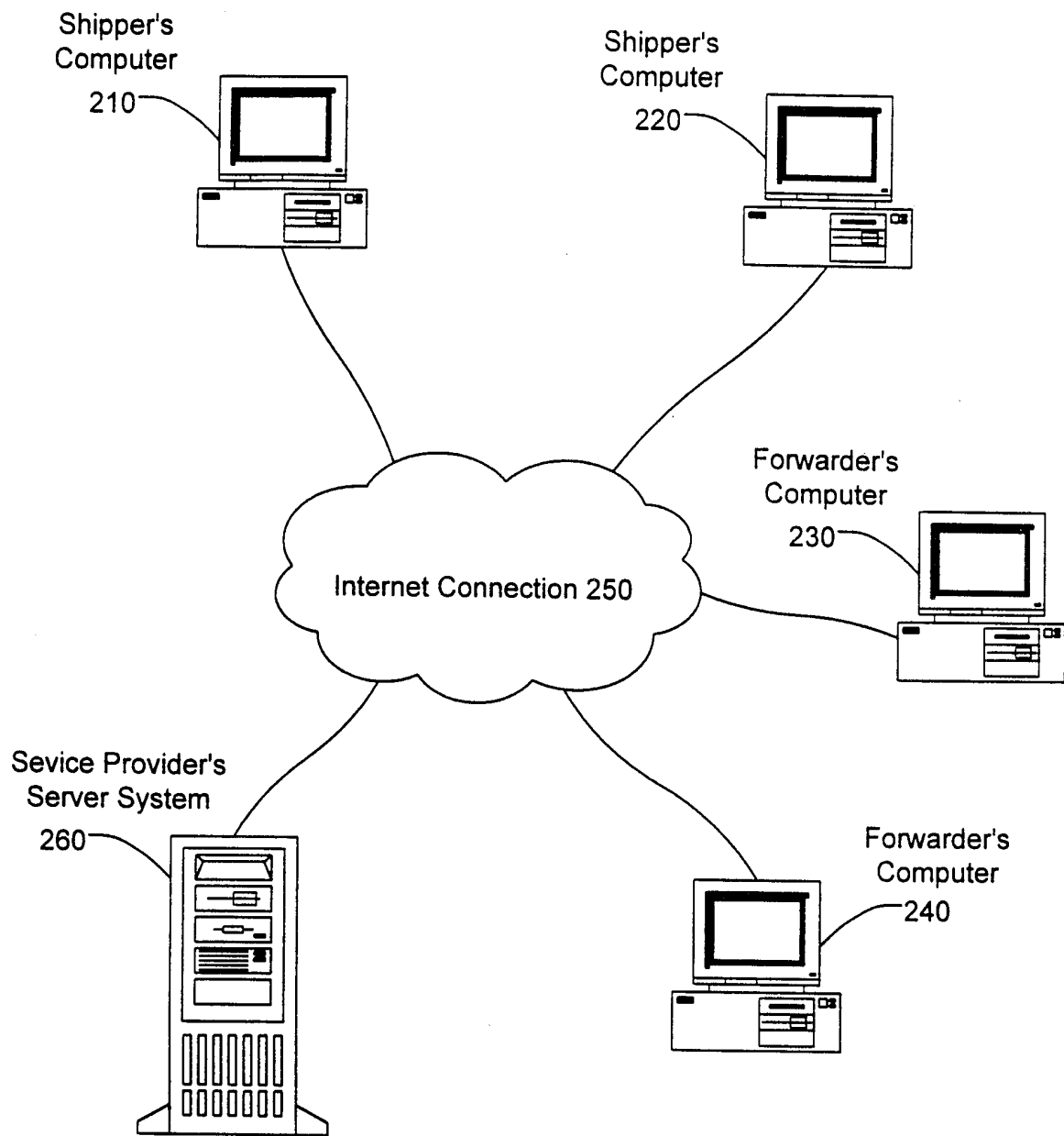

FIG. 2

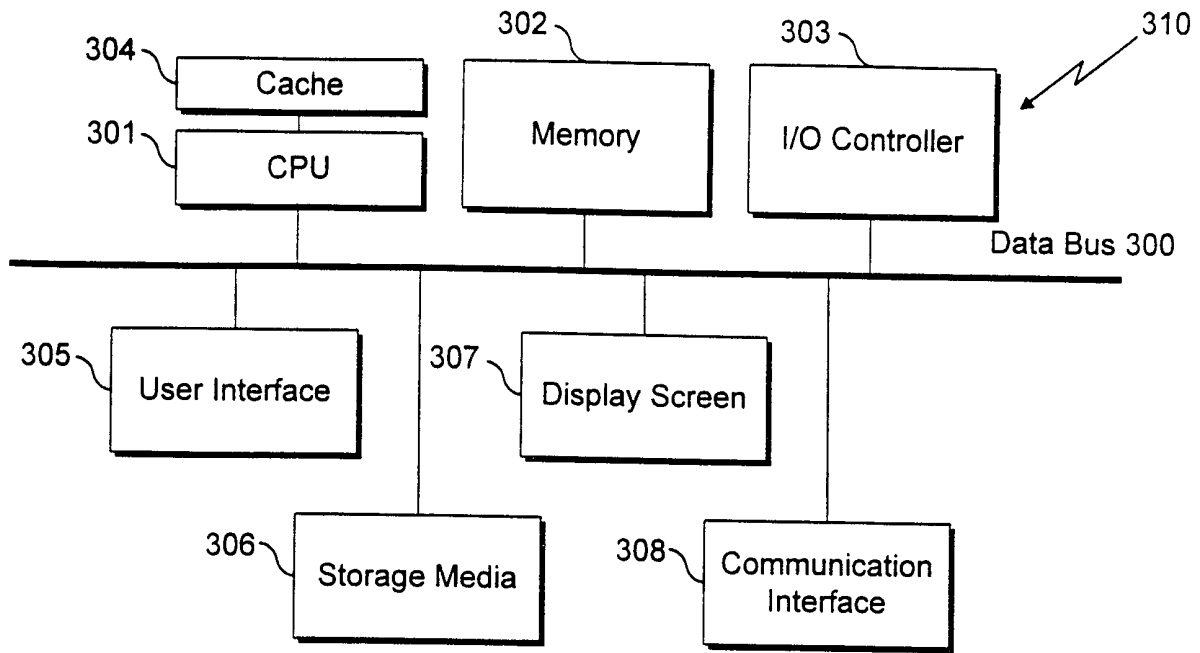

FIG. 3A

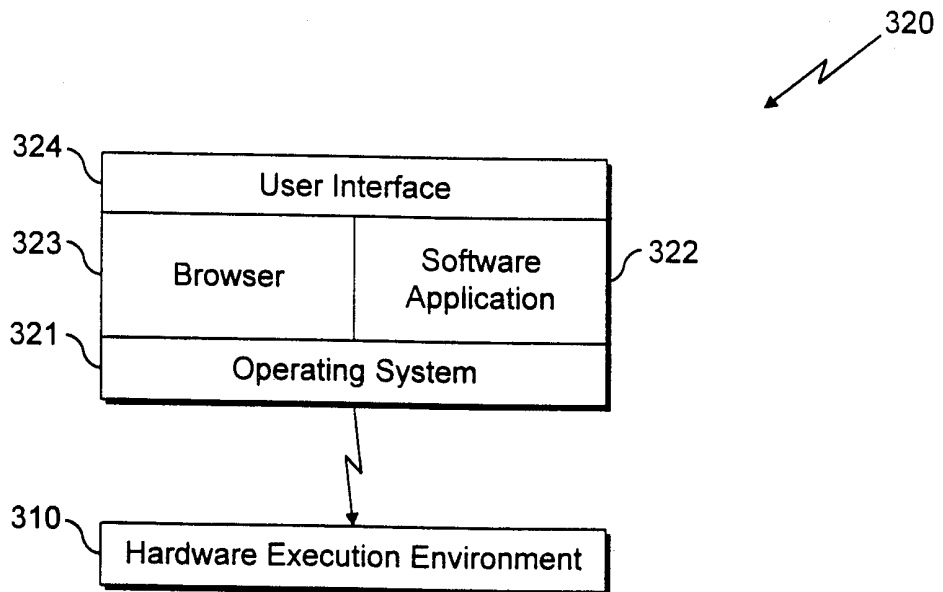

FIG. 3B

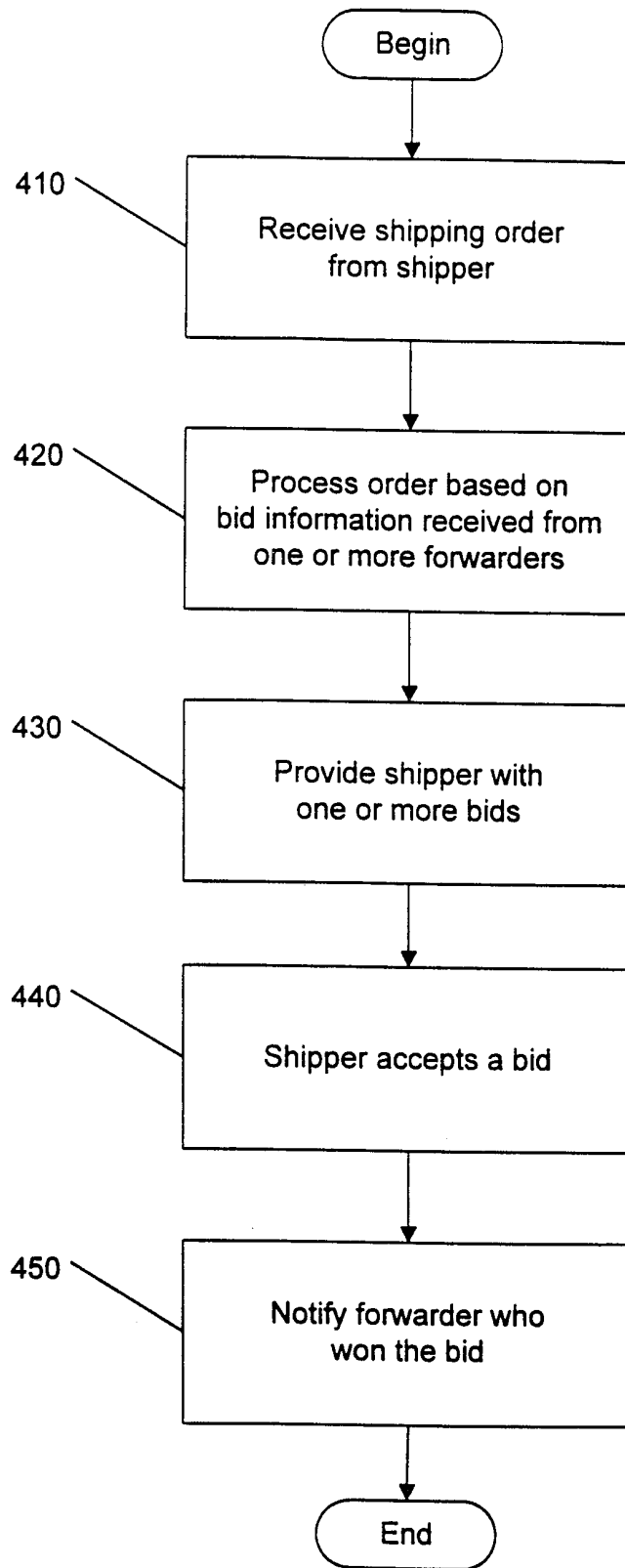

FIG. 4

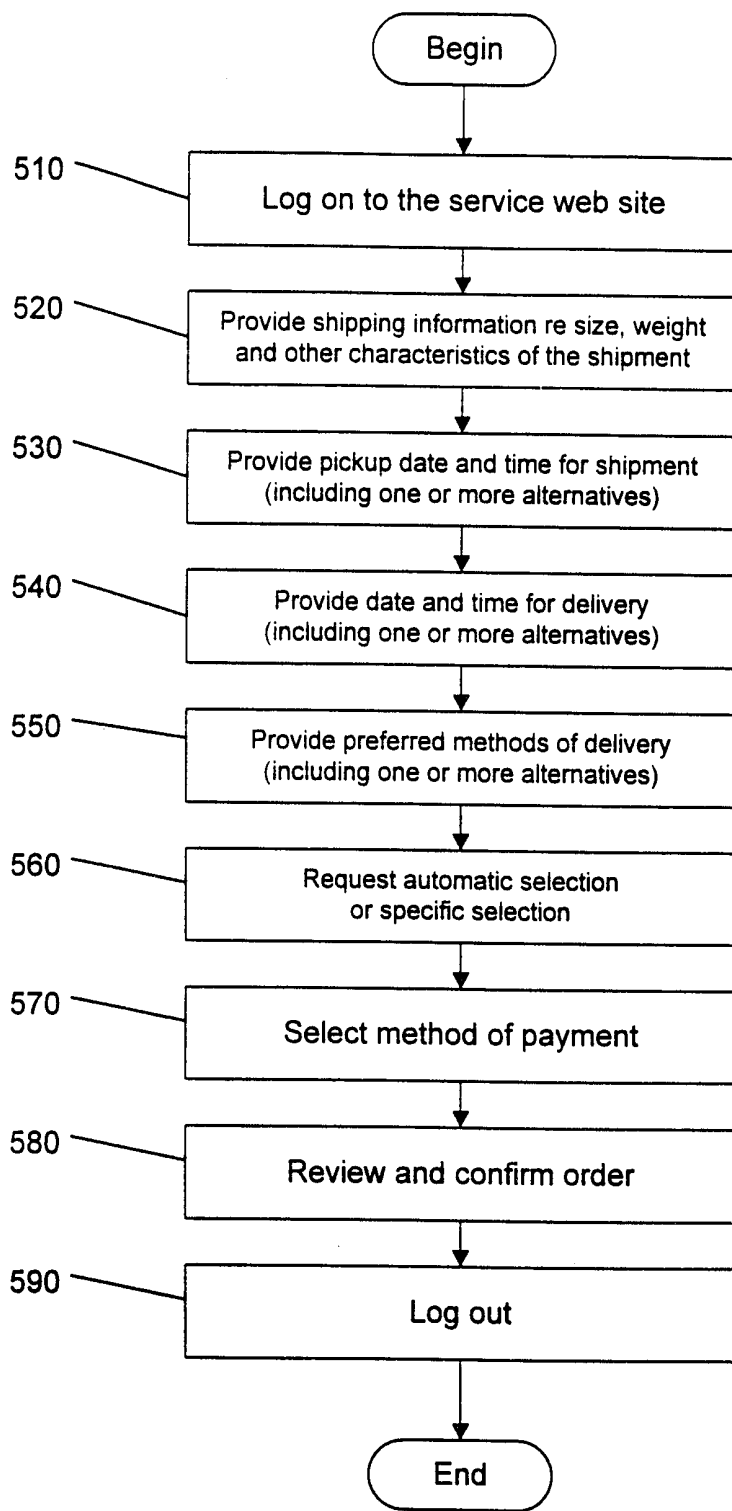

FIG. 5

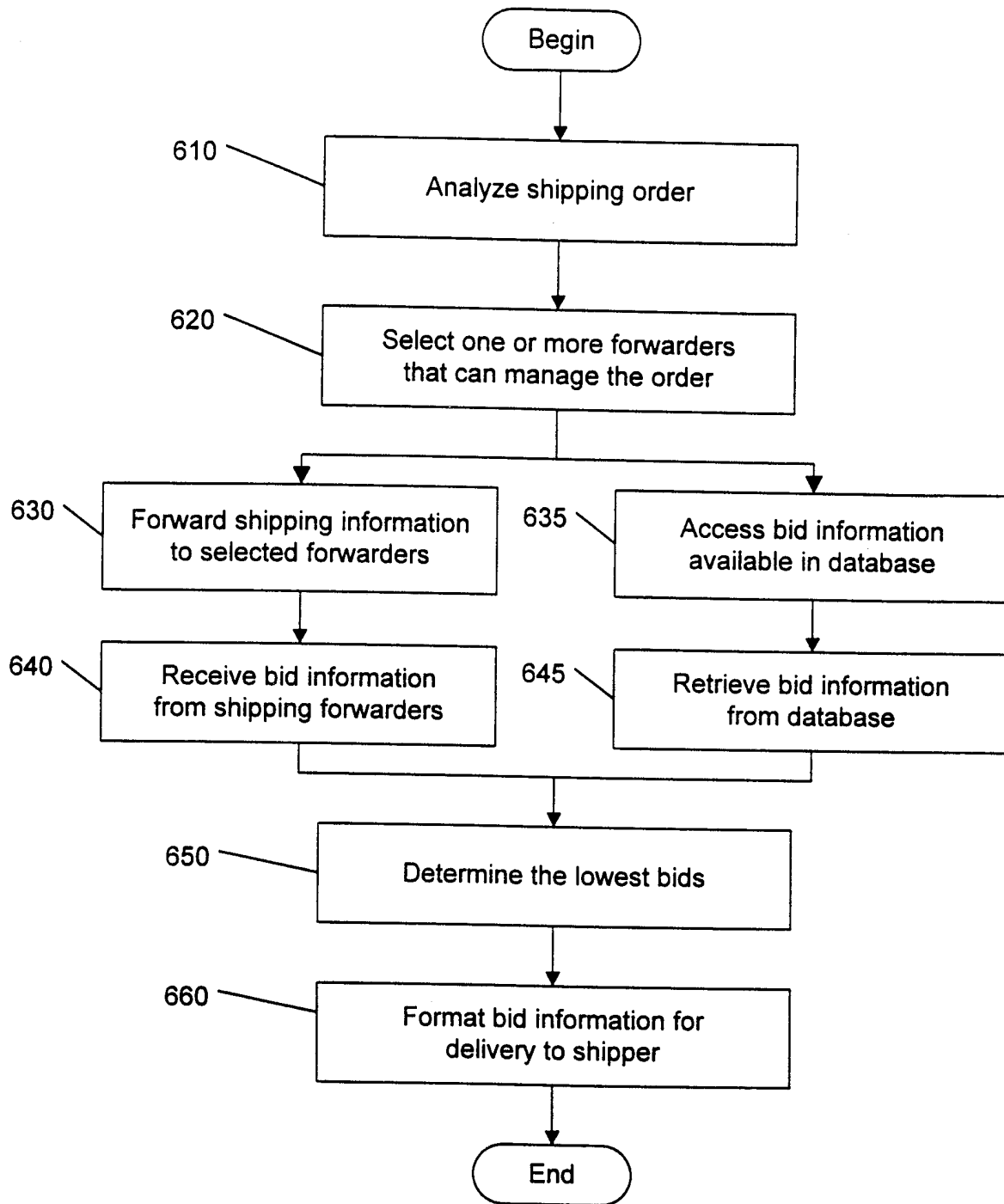

FIG. 6