



US00D714877S

(12) **United States Design Patent**  
**Kneitel**

(10) **Patent No.:** **US D714,877 S**

(45) **Date of Patent:** **\*\* Oct. 7, 2014**

(54) **GAMING CHIP RACK**

D692,067 S \* 10/2013 Miller et al. .... D21/392  
D692,068 S \* 10/2013 Miller et al. .... D21/392

(71) Applicant: **Ashford Kneitel**, Las Vegas, NV (US)

\* cited by examiner

(72) Inventor: **Ashford Kneitel**, Las Vegas, NV (US)

*Primary Examiner* — George D Kirschbaum

(73) Assignee: **Ashford Gaming LLC**, Las Vegas, NV (US)

(74) *Attorney, Agent, or Firm* — Jennifer Riel; Riel Law

(\*\*) Term: **14 Years**

(57) **CLAIM**

The ornamental design for a gaming chip rack, as shown and described.

(21) Appl. No.: **29/460,273**

**DESCRIPTION**

(22) Filed: **Jul. 9, 2013**

(51) **LOC (10) Cl.** ..... **21-01**

(52) **U.S. Cl.** ..... **D21/392**  
USPC .....

(58) **Field of Classification Search**  
USPC ..... D21/307-308, 334-368, 376-397;  
273/236-287, 288-291  
See application file for complete search history.

FIG. 1 is a perspective view of a gaming chip rack;  
FIG. 2 is a perspective view thereof;  
FIG. 3 is a front elevational view thereof;  
FIG. 4 is a rear elevational view thereof;  
FIG. 5 is a right side elevational view thereof;  
FIG. 6 is a left side elevational view thereof;  
FIG. 7 is a top plan view thereof; and,  
FIG. 8 is a bottom plan view thereof.

In the drawing figures, the broken lines in FIGS. 1, 3, 4, 7 and 8 depict apertures for a locking system while the broken lines in FIG. 2 show gaming chips and apertures for a locking system for illustrative purposes only and form no part of the claimed design.

(56) **References Cited**

**U.S. PATENT DOCUMENTS**

7,815,048 B2 \* 10/2010 Bean ..... 206/445  
D692,066 S \* 10/2013 Miller et al. .... D21/392

**1 Claim, 6 Drawing Sheets**

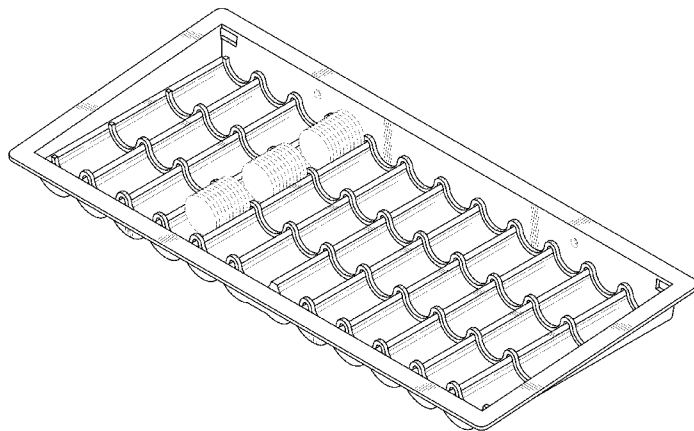
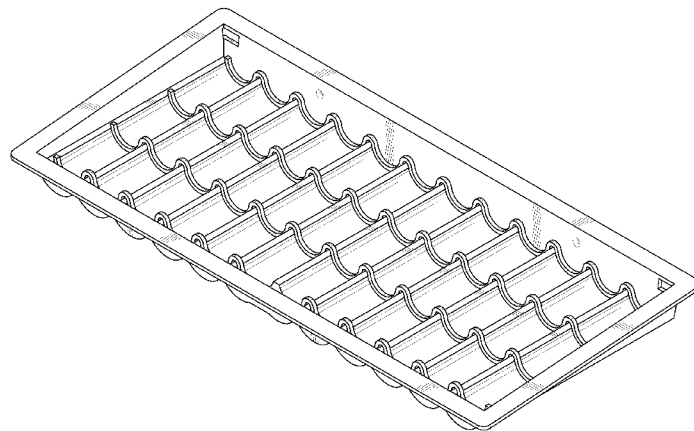

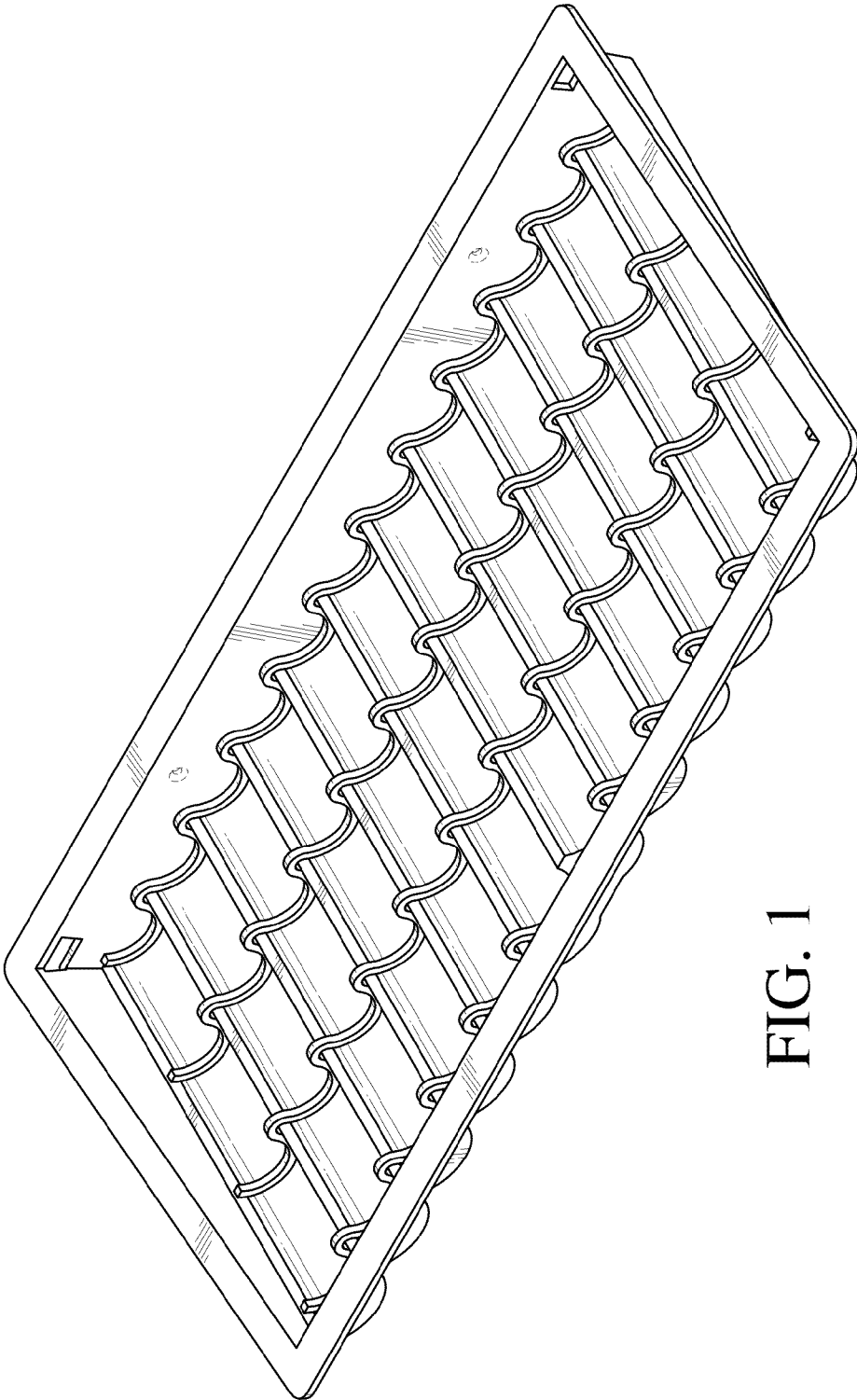

FIG. 1

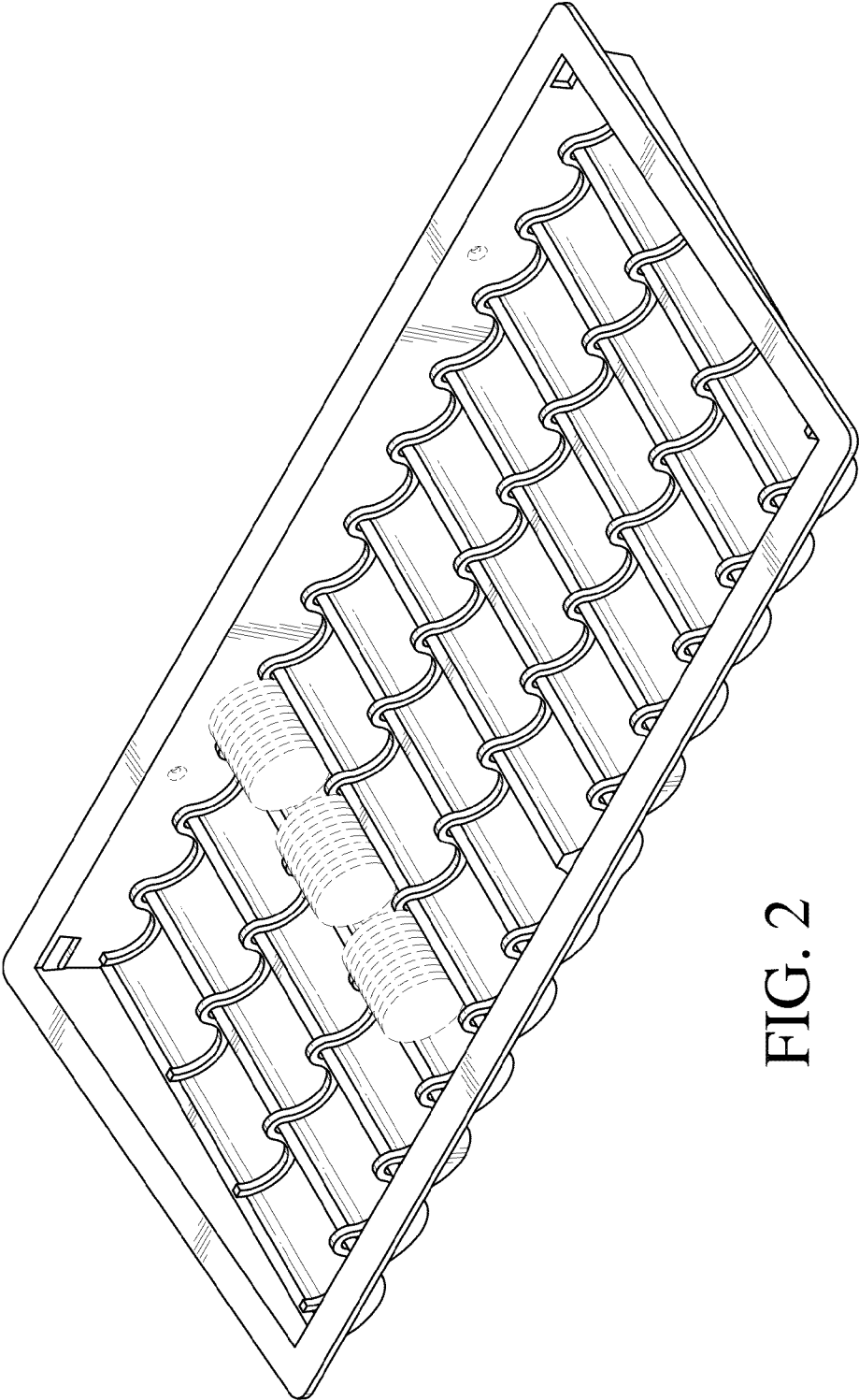

FIG. 2

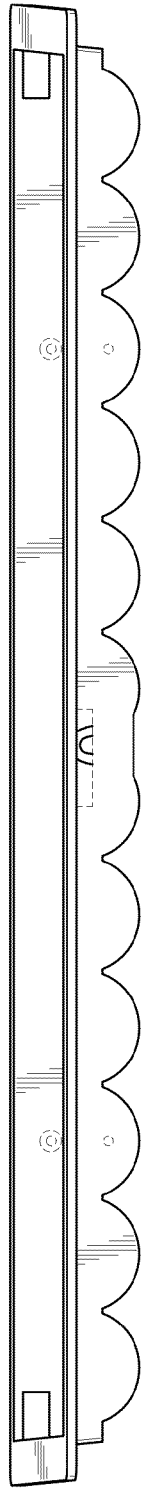

FIG. 3

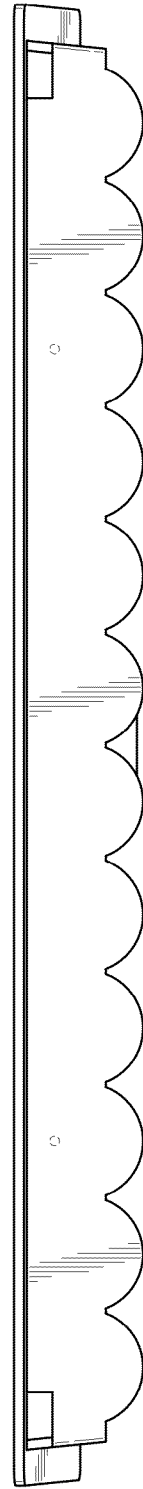

FIG. 4

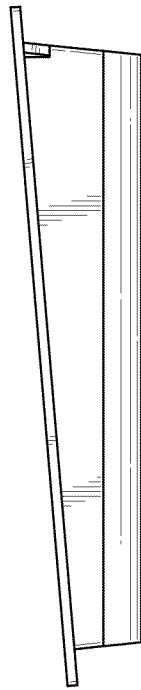

FIG. 5

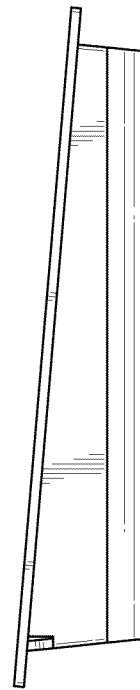

FIG. 6

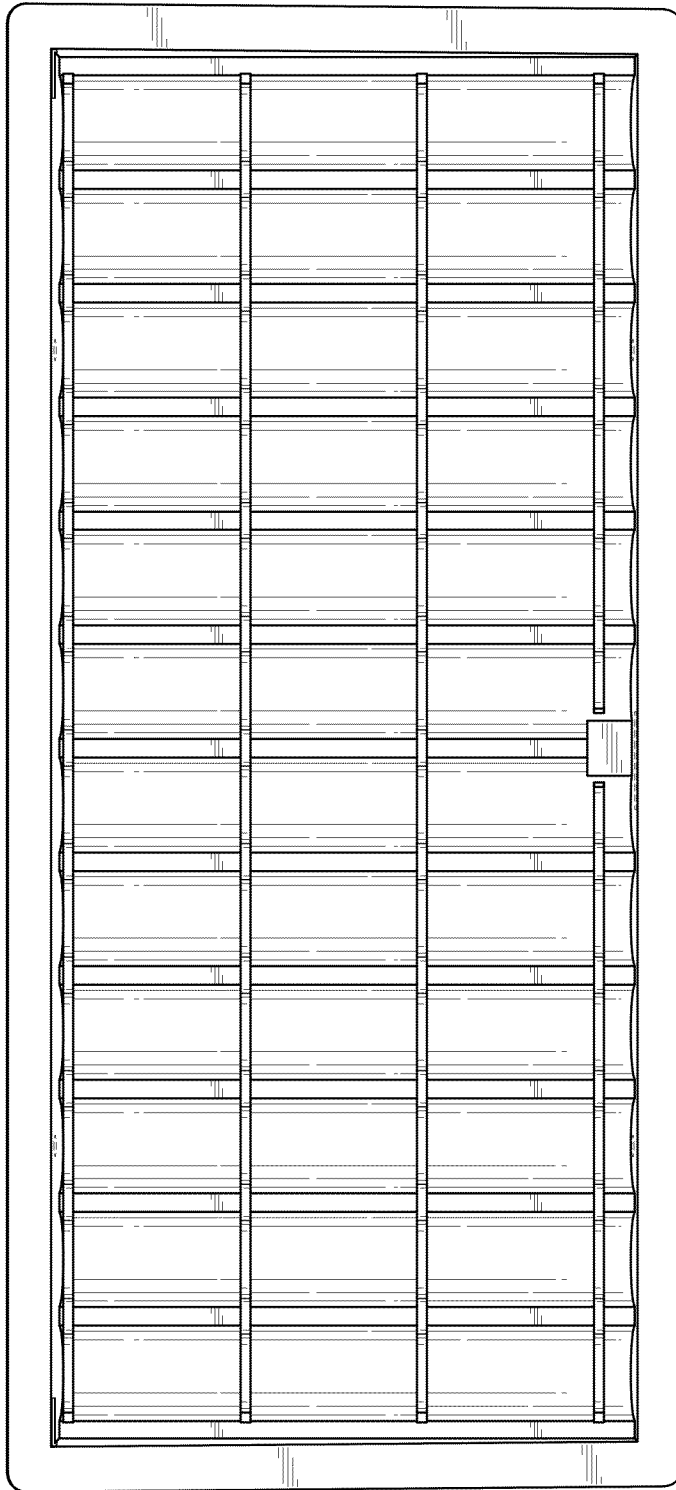

FIG. 7

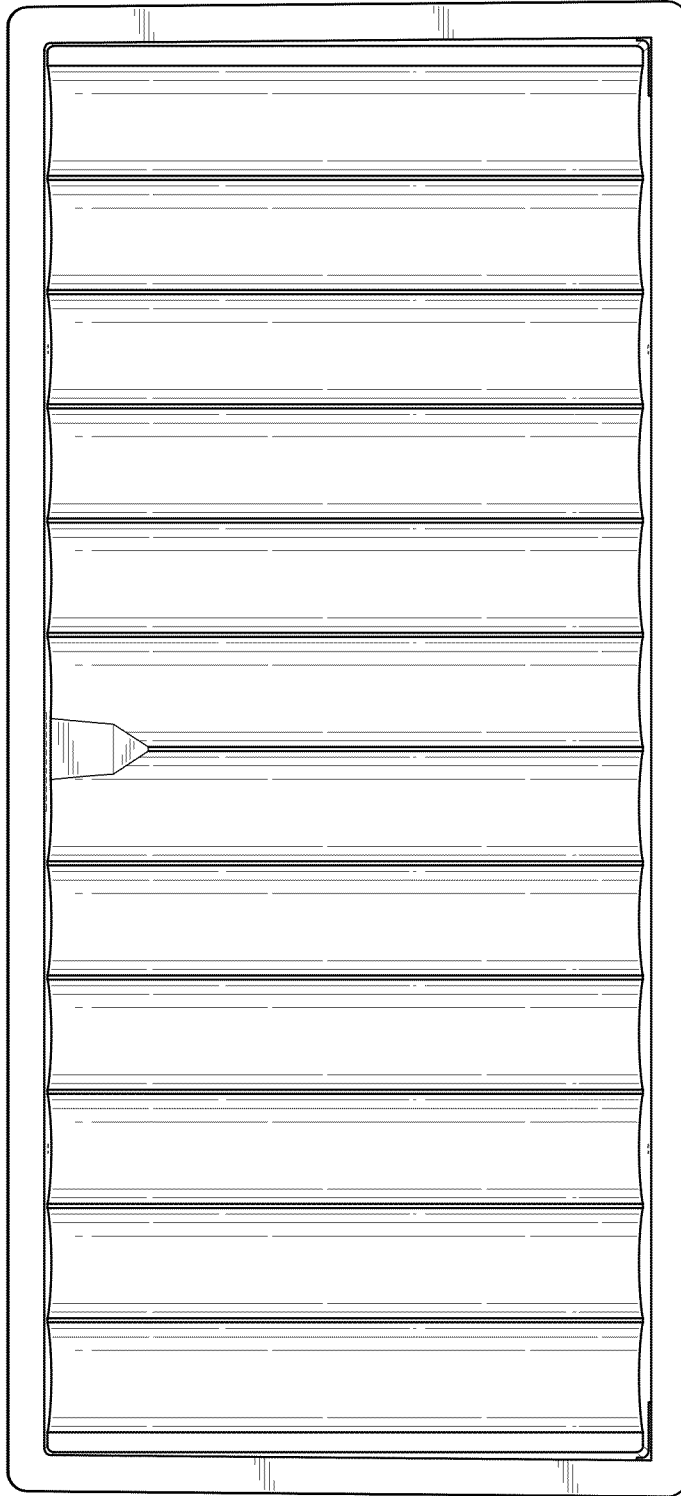

FIG. 8