

G. M. ADAMS.  
 OIL BURNER.  
 APPLICATION FILED FEB. 2, 1911.

996,824.

Patented July 4, 1911.

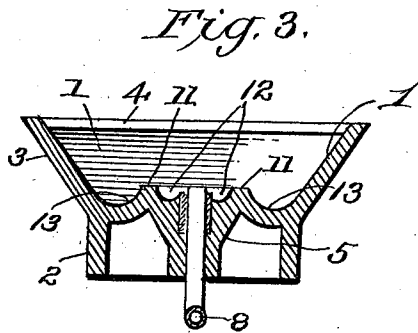
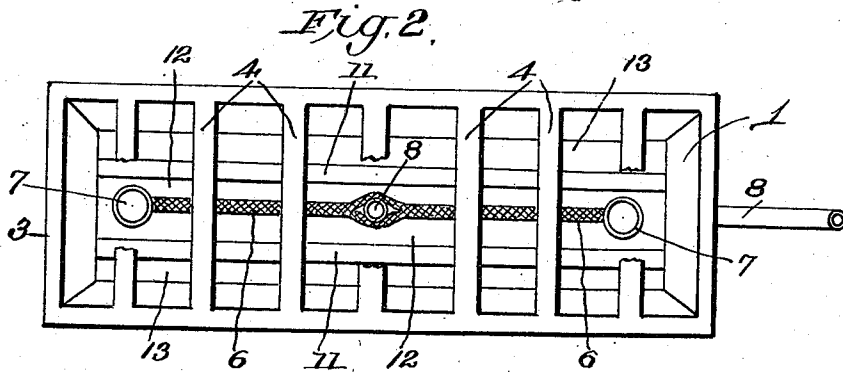
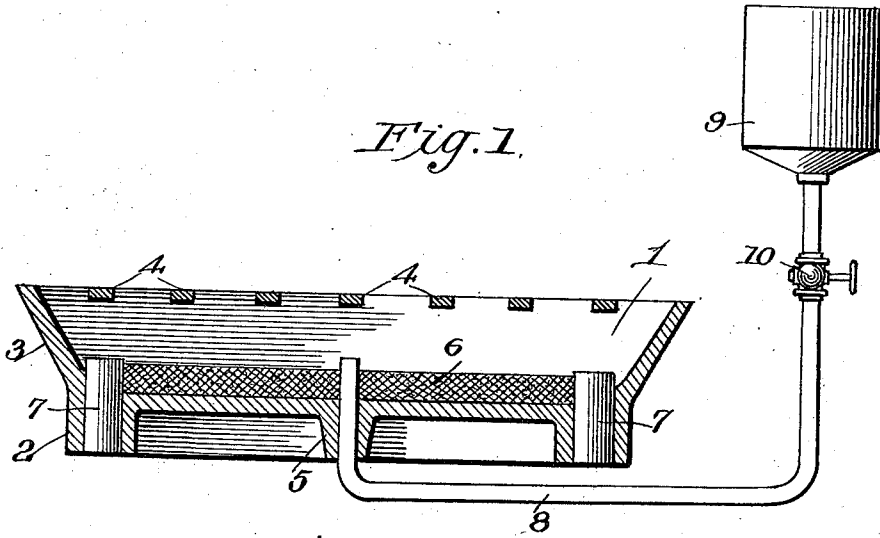

Inventor  
 G. M. Adams

Witnesses  
 Edna H. Thomas  
 Almon L. Thomas

By *Wm. C. W. Feltre*

Attorney

# UNITED STATES PATENT OFFICE.

GEORGE M. ADAMS, OF WANETTE, OKLAHOMA.

OIL-BURNER.

996,824.

Specification of Letters Patent.

Patented July 4, 1911.

Application filed February 2, 1911. Serial No. 606,236.

To all whom it may concern:

Be it known that I, GEORGE M. ADAMS, a citizen of the United States, residing at Wanette, in the county of Pottawatomie and State of Oklahoma, have invented certain new and useful Improvements in Oil-Burners; and I do hereby declare the following to be a full, clear, and exact description of the invention, such as will enable others skilled in the art to which it appertains to make and use the same.

This invention relates to improvements in oil burners, and particularly to the portable kind in which any form of cheap oil may be satisfactorily burned.

The object of the device is to provide a cheap, simple and reliable burner that will use any grade of oil and require little or no attention. The frame or casing is made in one piece, and can therefore be readily and easily cast, making a cheap and inexpensive form of burner.

With the above and other objects in view, the novelty of the invention resides in the peculiar formation, combinations and arrangement of parts to be hereinafter more particularly described, claimed and illustrated in the accompanying drawing, in which—

Figure 1 is a longitudinal vertical sectional view of the device; Fig. 2 is a top elevation with parts broken away and Fig. 3 is a transverse vertical sectional view.

Referring to the drawing by characters of reference, the numeral 1, represents a frame or casing having the downwardly extending sides or legs 2, and outwardly flanged upper sides 3. The upper flanged portion provides a rack or surface across which may be placed guides or bars 4 suitable for supporting cooking utensils, or any article which one desires to heat. A channel or groove is formed through the transverse upper surface of the bottom 5, of the frame 1, and provides a receptacle in which may be inserted the asbestos wick 6. This wick is set within the channel so as to extend a slight distance above the surrounding metal, and the bottom 5 is provided at each end of the wick 6 with air supply pipes 7, necessary to proper combustion. The center of the wick 6 is split and curved outwardly to provide a hole through its center, in which is inserted a fuel supply pipe 8. This pipe extends upward a short distance above the surface of the wick, the lower end extending down-

ward through the bottom 5, of the frame 1, and terminating in an oil reservoir 9, a suitable valve 10 being interposed in this pipe to provide means for regulating the supply of oil to the burner. The upward extensions 11 are formed on the bottom 5 of the casing 1, and extend on each side of the wick 6, being spaced a short distance outward so as to provide grooves 12 in which any surplus oil may accumulate and continue to feed to the wick. A second channel or groove 13 extends along the outer side of each upward extension 11, to provide a further overflow channel to retain any surplus oil that may run over in case the flame was extinguished and the valve not closed.

In operation the valve 10 is opened and oil allowed to flow out of the open end of the fuel supply pipe 8, thus running down and out on the asbestos wick 6, and will quickly follow along its entire length due to the capillary action. A match is then touched to the top of the wick, and the flame will then travel along its entire length, the air furnished by the pipes 7, being sufficient to cause the proper combustion.

Having thus fully described my invention what I claim as new and desire to secure by Letters Patent is:

1. The combination of an oil burner, an oil reservoir, and a feed pipe leading from the reservoir to the burner, said burner consisting of a casing, a longitudinal slot formed in the bottom of said casing, an asbestos wick inserted in said slot, said wick being split at its center and curved outwardly to form an opening, and air pipes extending up through the bottom of the casing at the ends of said wick, said feed pipe extending through the opening formed by said wick.

2. The combination of an oil burner, an oil reservoir, and a feed pipe leading from the reservoir to the burner, said burner consisting of a casing, a longitudinal slot formed in the bottom of said casing, an asbestos wick inserted in said slot, said wick being split at its center and curved outwardly to form an opening, said feed pipe extending through said opening, an upward projection formed in the bottom of said casing, and spaced a slight distance away from the wick, substantially as described.

3. The combination of an oil burner, an oil reservoir, and a feed pipe leading from

the reservoir to the burner, said burner consisting of a casing, a longitudinal slot formed in the bottom of said casing, an asbestos wick inserted in said slot, said wick  
5 being split at its center and curved outwardly to form an opening, said feed pipe extending through said opening, air pipes extending up through the bottom of the casing at the ends of the wick, an upward pro-  
10 jection formed in the bottom of the casing and slightly spaced away from the wick, and

a channel formed in the bottom of the casing extending around the outside of said upper projection, substantially as and for the purposes described. 15

In testimony whereof I affix my signature in presence of two witnesses.

GEORGE M. ADAMS.

Witnesses:

WM. BEATTY,  
NORMA BEATTY.

---

Copies of this patent may be obtained for five cents each, by addressing the "Commissioner of Patents, Washington, D. C."

---