



(86) Date de dépôt PCT/PCT Filing Date: 2006/12/11  
 (87) Date publication PCT/PCT Publication Date: 2007/07/05  
 (45) Date de délivrance/Issue Date: 2010/10/19  
 (85) Entrée phase nationale/National Entry: 2008/05/12  
 (86) N° demande PCT/PCT Application No.: US 2006/047181  
 (87) N° publication PCT/PCT Publication No.: 2007/075319  
 (30) Priorité/Priority: 2005/12/27 (US11/317,255)

(51) Cl.Int./Int.Cl. *E06B 3/00* (2006.01)  
 (72) Inventeur/Inventor:  
THEIOS, JASON, US  
 (73) Propriétaire/Owner:  
GUARDIAN INDUSTRIES CORP., US  
 (74) Agent: MACPHERSON LESLIE & TYERMAN LLP

(54) Titre : FENETRE A VALEUR R ELEVEE MUNIE D'UN VITRAGE ISOLANT SOUS VIDE ET ENCADREMENT ISOLANT

(54) Title: HIGH R-VALUE WINDOW UNIT WITH VACUUM IG UNIT AND INSULATING FRAME

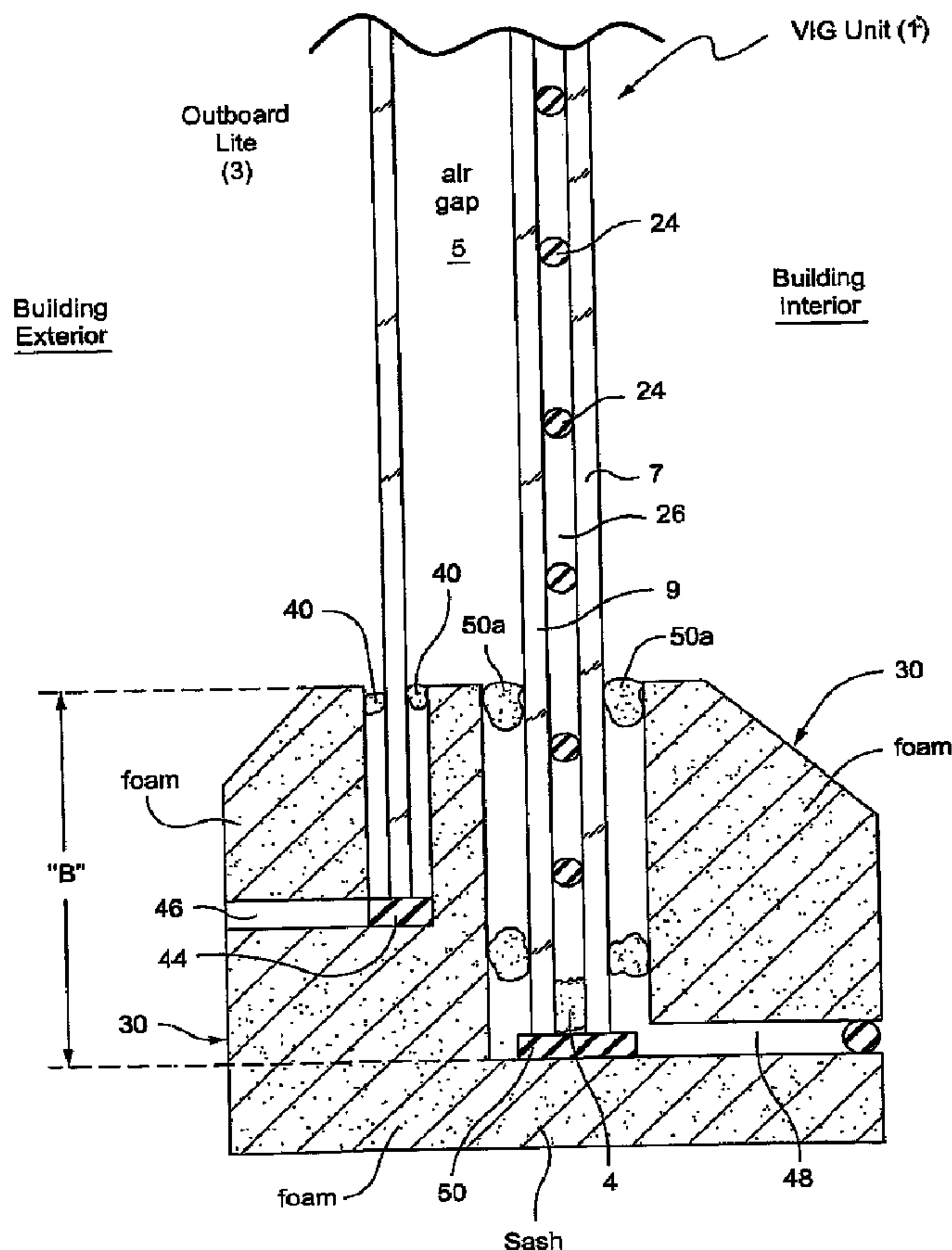

(57) Abrégé/Abstract:

In certain example embodiments of this invention, a window unit may include a vacuum IG (ViG) unit as an inboard lite and a monolithic lite (e.g., with an optional low-E coating; thereon) as an outboard lite. A dead air space may separate the inboard and

(57) **Abrégé(suite)/Abstract(continued):**

outboard lites. A highly insulated frame may be used to support the inner and outer lites. The VIG unit may be partially embedded or supported in the insulative frame, so that the insulating frame separates the VIG unit inboard lite from the outboard lite thereby reducing conductivity around the edges of the window unit so that R-value can be increased (and U-value decreased). In certain example embodiments, the total R-value of the window unit is at least about R-8, and more preferably at least about R-10 (compared to the much lower R-values of conventional IG units).

(12) INTERNATIONAL APPLICATION PUBLISHED UNDER THE PATENT COOPERATION TREATY (PCT)

(19) World Intellectual Property Organization  
International Bureau



(43) International Publication Date  
5 July 2007 (05.07.2007)

PCT

(10) International Publication Number  
**WO 2007/075319 A3**

(51) International Patent Classification:  
*E06B 3/00* (2006.01)

(74) Agent: **RHOA, Joseph, A.**; NIXON & VANDERHYE P.C., 901 NORTH GLEBE ROAD, 11TH FLOOR, Arlington, VA 22203-1808 (US).

(21) International Application Number:  
PCT/US2006/047181

(81) Designated States (unless otherwise indicated, for every kind of national protection available): AE, AG, AL, AM, AT, AU, AZ, BA, BB, BG, BR, BW, BY, BZ, CA, CH, CN, CO, CR, CU, CZ, DE, DK, DM, DZ, EC, EE, EG, ES, FI, GB, GD, GE, GH, GM, GT, HN, HR, HU, ID, IL, IN, IS, JP, KE, KG, KM, KN, KP, KR, KZ, LA, LC, LK, LR, LS, LT, LU, LV, LY, MA, MD, MG, MK, MN, MW, MX, MY, MZ, NA, NG, NI, NO, NZ, OM, PG, PH, PL, PT, RO, RS, RU, SC, SD, SE, SG, SK, SL, SM, SV, SY, TJ, TM, TN, TR, TT, TZ, UA, UG, US, UZ, VC, VN, ZA, ZM, ZW.

(22) International Filing Date:  
11 December 2006 (11.12.2006)

(25) Filing Language: English

(26) Publication Language: English

(30) Priority Data:  
11/317,255 27 December 2005 (27.12.2005) US

(71) Applicant (for all designated States except US):  
**GUARDIAN INDUSTRIES CORP.** [US/US]; 2300 HARMON ROAD, Auburn Hills, MI 48326-1714 (US).

(84) Designated States (unless otherwise indicated, for every kind of regional protection available): ARIPO (BW, GH, GM, KE, LS, MW, MZ, NA, SD, SL, SZ, TZ, UG, ZM, ZW), Eurasian (AM, AZ, BY, KG, KZ, MD, RU, TJ, TM), European (AT, BE, BG, CH, CY, CZ, DE, DK, EE, ES, FI, FR, GB, GR, HU, IE, IS, IT, LT, LU, LV, MC, NL, PL, PT, RO, SE, SI, SK, TR), OAPI (BF, BJ, CF, CG, CI, CM, GA, GN, GQ, GW, ML, MR, NE, SN, TD, TG).

(72) Inventor; and  
(75) Inventor/Applicant (for US only): **THEIOS, Jason** [US/US]; 6303 NORTHBROOK LANE, Toledo, OH 43612 (US).

[Continued on next page]

(54) Title: HIGH R-VALUE WINDOW UNIT WITH VACUUM IG UNIT AND INSULATING FRAME

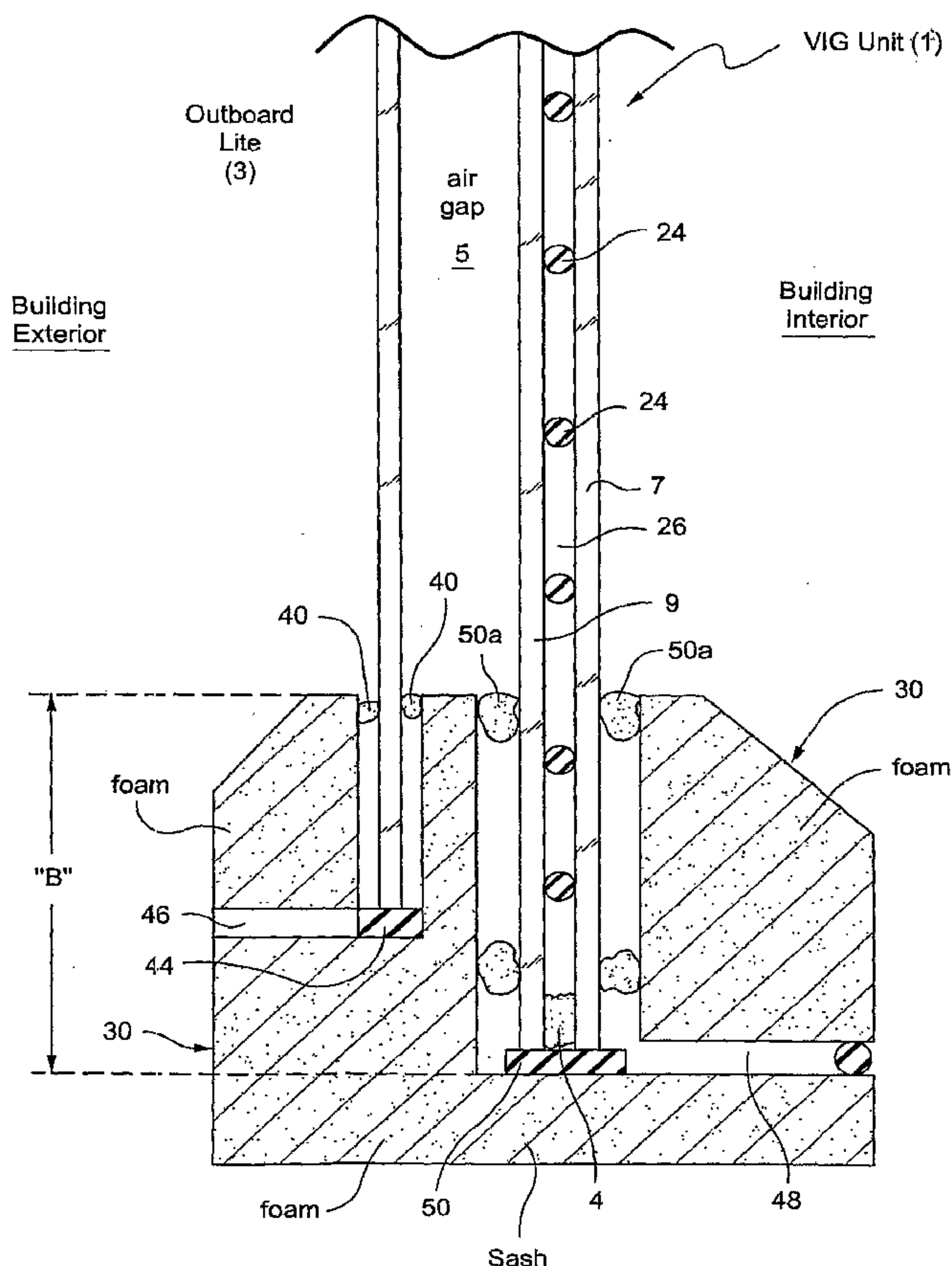

(57) Abstract: In certain example embodiments of this invention, a window unit may include a vacuum IG (VIG) unit as an inboard lite and a monolithic lite (e.g., with an optional low-E coating; thereon) as an outboard lite. A dead air space may separate the inboard and outboard lites. A highly insulated frame may be used to support the inner and outer lites. The VIG unit may be partially embedded or supported in the insulative frame, so that the insulating frame separates the VIG unit inboard lite from the outboard lite thereby reducing conductivity around the edges of the window unit so that R-value can be increased (and U-value decreased). In certain example embodiments, the total R-value of the window unit is at least about R-8, and more preferably at least about R-10 (compared to the much lower R-values of conventional IG units).

WO 2007/075319 A3

**WO 2007/075319 A3**



**Published:**

- *with international search report*
- *before the expiration of the time limit for amending the claims and to be republished in the event of receipt of amendments*

*For two-letter codes and other abbreviations, refer to the "Guidance Notes on Codes and Abbreviations" appearing at the beginning of each regular issue of the PCT Gazette.*

**(88) Date of publication of the international search report:**

31 January 2008

## TITLE OF THE INVENTION

HIGH R-VALUE WINDOW UNIT WITH VACUUM IG UNIT AND  
INSULATING FRAME

**[0001]** This application relates to a window unit designed so as to have a high R-value. In certain example embodiments, the window unit includes a vacuum IG (VIG) unit as an inboard lite and a monolithic lite (e.g., with a low-E coating thereon, optionally) as an outboard lite; where a dead air space separates the two lites which are both supported by an insulating frame such as a sash. The design may result in a higher and thus improved R-value for the window unit.

## BACKGROUND AND SUMMARY OF THE INVENTION

**[0002]** It is known in the art that R-value is a measure of the insulating characteristics of a window. In particular, R-value is the reciprocal of U-value. In other words,  $U \text{ value} = 1/R\text{-value}$ . The term U-value or U-factor (synonymous with thermal transmittance) is well understood in the art and is used herein according to this well known meaning. U-value herein is reported in terms of BTU/hr/ft<sup>2</sup>/degrees F, and may be determined according to the guarded hot box method as reported in and according to ASTM designation C1199-91.

Similarly, R-value is the reciprocal of U-value as explained above.

**[0003]** The R-value for a monolithic glass sheet (one sheet of glass) is typically around 1.0. Moreover, the R-value for an insulating glass (IG) unit with two sheets of uncoated glass spaced apart from each other is typically about 2.0 (i.e., U value of about 0.5). When one of the glass sheets of an IG unit is coated with a low-E (low emissivity) coating, the R value can be increased (e.g., to about 3 or 4). Argon gas between the glass sheets of an IG unit can also increase R-value (and thus decrease U-value).

**[0004]** Conventional IG units often use metal spacer(s) as the edge of the units to space the glass sheets from one another. However, this causes U values to be higher (and thus R values to be lower) at the edges of such IG units due to the conductivity of the metal spacer(s). It would be advantageous to avoid the use of

metal spacers at edges of a glass-based window unit, thereby reducing conductivity of the spacing structure. Plastic spacers have been used previously to address this problem, but have resulted in gas (e.g., Ar) leakage through the plastic thereby leading to durability and insulating problems.

[0005] In certain example embodiments of this invention, a window unit may be provided which does not necessarily need a metal spacer in an IG unit. In certain example embodiments, a window sash has a spacer function/structure which may be of plastic or the like; e.g., vinyl or some other polymer based material. Thus, in certain example embodiments, part of the sash may separate two glass sheets of the window from one another.

[0006] In certain example embodiments of this invention, a window unit may include a vacuum IG (VIG) unit as an inboard lite and a monolithic lite (e.g., with a low-E coating thereon) as an outboard lite. A dead air space may separate the inboard and outboard lites. Moreover, in certain example embodiments, a highly insulated frame may be used to support the inner and outer lites. The VIG unit may be partially embedded or supported (e.g., by from about 1-6 inches, more preferably from about 1 to 3 inches, with an example being about 2 inches) in the insulating frame, so that the insulating frame separates the VIG unit inboard lite from the outboard lite thereby reducing conductivity around the edges of the window unit so that R-value can be increased (and U-value increased). In certain example embodiments, the edges of the inboard and outboard lites may be vertically offset from one another, to further reduce conductivity at edges portions. In certain example embodiments, the total R-value of the window unit is at least about R-8, and more preferably at least about R-10 (compared to the much lower R-values of conventional IG units).

[0007] In certain example embodiments, there is provided a window unit comprising: an insulating frame in which a vacuum IG unit and a monolithic lite are provided, the vacuum IG unit including first and second spaced apart glass sheets that are separated from one another via a gap that is a pressure less than atmospheric, and the monolithic lite being spaced apart from the vacuum IG unit; wherein the frame comprises insulating material that separates the vacuum IG unit from the monolithic lite.

**[0008]** In other example embodiments of this invention, there is provided a window unit comprising: an insulating frame in which both an inboard glass lite and an outboard glass lite are partially embedded, the inboard lite comprising a vacuum IG unit including first and second spaced apart glass sheets that are separated from one another via a gap that is a pressure less than atmospheric, and the outboard lite comprising a monolithic glass sheet spaced apart from the vacuum IG unit; wherein the frame comprises insulating material that separates the outer surface of the vacuum IG unit from the inner surface of the monolithic glass sheet; and wherein along at least one of a top edge, a bottom edge, and/or a side edge of the window unit, the outer edge of the monolithic glass sheet is vertically offset from the outer edge of the vacuum IG unit so that the outer edge of the vacuum IG unit is closer to a periphery of the window unit than is the outer edge of the monolithic glass sheet.

#### BRIEF DESCRIPTION OF THE DRAWINGS

**[0009]** FIGURE 1 is a cross sectional view of a window unit according to an example embodiment of this invention.

#### DETAILED DESCRIPTION OF EXAMPLE EMBODIMENTS OF THE INVENTION

**[0010]** Fig. 1 is a cross sectional view of a window unit according to an example embodiment of this invention. Fig. 1 illustrates that the window unit includes a vacuum IG (VIG) unit 1 as an inboard lite and a monolithic lite 3 as an outboard lite. A dead air space 5 separates the inboard and outboard lites. Space 5 may be at atmospheric pressure in certain example embodiments, although it may instead be filled with gas and/or at a pressure lower than atmospheric in different example embodiments. In certain example embodiments, a low-E coating for reflecting IR radiation may be provided on the surface of monolithic lite 3 facing the air gap 5, although such a low-E coating is optional in certain example embodiments of this invention. Example low-E coatings are described in U.S. Patent Nos. 6,936,347, 5,688,585, 5,557,462, 5,425,861, 4,413,877 and 3,682,528.

[0011] The vacuum IG unit 1, which is the inboard lite in Fig. 1, includes an inner glass substrate 7 and an outer glass substrate 9. Edges of opposing vacuum IG substrates 7 and 9 are hermetically sealed by at least one edge or peripheral seal 4. "Peripheral" and "edge" seals herein do not mean that the seal(s) are located at the absolute periphery or edge of the unit, but instead mean that the seal is at least partially located at or near (e.g., within about two inches of) an edge of at least one substrate of the VIG unit. In certain example embodiments, a vacuum IG unit includes first and second opposing glass substrates 7 and 9 (tempered or non-tempered) which are spaced from one another by spacers or pillars 24 which maintain low pressure space 26 between the substrates. In certain example embodiments, substrates 7 and 9 are soda-lime-silica float glass. Hermetic peripheral or edge seal 4, provided between the substrates 7 and 9, seals off low pressure space 26 from surrounding atmospheric pressure. The peripheral/edge seal 4 may be located entirely between the opposing substrates, as shown in Figure 1. However, the peripheral/edge seal 4 may instead be located partially between substrates 7 and 9, and partially in an L-shaped step area (not shown) at the periphery of the unit in non-illustrated instances where the glass sheets 7 and 9 are of different sizes. The evacuation of space 26 eliminates or reduces heat transport between glass substrates 7 and 9 due to gaseous conduction and convection. In addition, radiative heat transport between substrates 7 and 9 can be reduced to a low level by providing an optional low-E coating(s) on a surface of one or both of sheets 7, 9. High levels of thermal insulation can thus be achieved. Low gaseous thermal conduction may be achieved when the pressure in space 26 is reduced to a level e.g., equal to or below about  $0.5 \times 10^{-3}$  Torr, more preferably below about 0.1 mTorr, or  $10^{-4}$  Torr, and most preferably below about  $10^{-6}$  Torr of atmospheric pressure. The hermetic sealing system 4, including one or more edge seals, substantially eliminates any ingress or outgress of gas or air to/from low pressure space 26. An array of spacers or pillars 24 is provided between substrates 7 and 9 in order to maintain separation of the two approximately parallel glass sheets 7, 9 against atmospheric pressure. In certain embodiments, all spacers 24 are of approximately the same size and/or material. However, in other embodiments, there may be different sizes of spacers 24 in the same vacuum IG unit. In certain embodiments, the density of spacers (i.e., the number of spacers per unit area) may be

greater in certain areas than in other areas, or alternatively, the density of the spacers may be approximately uniform throughout the entire unit. For purposes of example only, and without limitation, example VIG units which may be used for VIG unit 1 in the Fig. 1 embodiment are illustrated and/or described in U.S. Patents Nos. 6,372,312, 6,365,242, 6,399,169, 6,336,984, 6,497,931, and/or 6,692,600.

**[0012]** In certain example embodiments, a highly insulated foam core insulating frame 30 may be used to support the inner and outer lites 1, 3. In certain example embodiments, the foam functions as insulating so as to provide an insulating function and structure for supporting the lites 1, 3. The insulating frame 30 may be a window sash in certain example embodiments of this invention, and may have a polymer based cover (e.g., vinyl) surrounding a foam core in certain example instances. The VIG unit 1 may be partially embedded or supported (e.g., by from about 1-6 inches, more preferably from about 1 to 3 inches, with an example being about 2 inches) in the foam frame 30, so that the foam inclusive insulating frame 30 separates the VIG unit inboard lite 1 from the monolithic outboard lite 3 thereby reducing conductivity around the edges of the window unit so that R-value can be increased (and U-value increased).

**[0013]** In certain example embodiments, as shown in Fig. 1, the edges of the inboard and outboard lites 1 and 3 may be vertically offset from one another, to further reduce conductivity at edges portions. VIG units tend to have some conductivity between the two glass sheets thereof at the edge area near seal 4. However, the vertical offset between the bottom edge (and possible the upper and/or side edges also) of the VIG unit 1 and that of the monolithic lite 3 helps reduce conductivity between the edges of lites 1 and 3 for the overall window unit thereby improving the R-value thereof. The VIG lite 1 is located on the inboard side in certain example embodiments, so as to avoid temperature swings on the inner side of the window unit and to protect the VIG unit from potential damage from the exterior of the building on which the window unit is located. It is also noted that the fairly long bite "B" between the bottom edge of the VIG unit and the upper edge of the bottom frame portion advantageously makes it more difficult for heat and/or cold to

makes its way around the edge of the VIG unit 1 thru the possible solder edge seal 4. The distance of bite "B" is from about 1 to 5 inches, more preferably from about 1-3 inches (e.g., 2 inches) in certain example embodiments of this invention.

[0014] In certain example embodiments, the total R-value of the window unit is at least about R-8, and more preferably at least about R-10 (compared to the much lower R-values of conventional IG units).

[0015] In the Fig. 1 embodiment, the outer monolithic lite 3 may be glued to the sash/frame 30 via adhesive at area 40 which may also function as a seal. Bottom stop 44 upon which outboard lite 3 rests in first L-shaped channel 46 is optional. L-shaped channel 46 is defined in the frame/sash 30, with the vertical portion of the channel 46 receiving the lite 3 and the horizontal portion of the channel permitting the optional stop 44 to be inserted and/or removed. Glue may also be put in the channel 46 to hold the lite 3 in place. A second L-shaped channel 48 is also provided in the sash or frame 30. Second L-shaped channel 48 is also defined in the frame/sash 30, with the vertical portion of the channel 48 receiving the VIG lite 1 and the horizontal portion of the channel permitting the optional stop 50 to be inserted and/or removed in the frame. Glue may also be put in the channel 48 to hold the VIG lite 1 in place. Again, the VIG lite 1 is held in place via glue at areas 50a in certain example instances.

[0016] In order to achieve a high R-value for the overall window unit, one typically has good insulating properties in three primary areas of the window; namely the center of the window (e.g., the daylight opening minus about a 2.5 inches perimeter near the siteline), the edge of the glass (e.g., the 2.5 inch perimeter of the daylight opening near the siteline, and the frame (e.g., the opaque structural component surrounding the glass that holds the glass in place). These three areas act in parallel for heat flow, and one area with very high thermal conductivity will allow undesirable large amounts of heat to flow through that channel. Typically, multiple layers of glass have been used to reduce heat flow through the center of the glass, although low-E coatings and gas such as Ar have also been used. Low conductivity spacers at the perimeter are typically used to reduce conductivity at the edge.

Framing is typically designed to hold a glazing unit with an approximately one-half inch bite on the edge of the unit.

[0017] The VIG unit 1 uses two sheets of glass 7 and 9 with an optional low-E coating on one of the glass sheets to reach a center-of-glass R-value of about 10 or more. However, the VIG unit 1 may have a solder glass edge seal 4 at or near the perimeter to seal the two glass sheets together, which allows for an easy path for heat to flow from one glass sheet to the other. The window of Fig. 1 however overcomes this problem with the VIG unit by embedding the edge of the VIG unit 1 in the insulating frame/sash 30 with a fairly long bite B. The combination of the insulating properties of glass along the path length around the edge of the VIG unit (two times the bite length) acts as a thermal barrier. The larger bite B results in a larger R-value for the window unit. In certain example embodiments, the frame 30 has a core of highly insulating foam such as polyisocyanurate (e.g., R-6.5 per inch) – two inches of this would provide an R-value of about 13. A protective layer of fiberglass reinforced plastic or wood veneer could also be used as the covering of the foam core, with the structure L-channels 46 and 48 designed to follow the isothermals of the heat flow in the framing system. The outside surface of the framing system could be expected to reach temperature extremes of -50 degrees F to plus 150 degrees F, such that the outer skin of the framing may be designed to flex to absorb such temperature extremes without causing significant warping for limited time periods. The outboard monolithic lite 3 helps shield the VIG unit 1 from certain temperature extremes.

[0018] In certain example embodiments, the overall window unit of example Fig. 1 may be characterized by the following R-values. First, center of glass: VIG = 10, outboard low-E lite = 2; total center of glass is about R-12 or more. Second, edge of glass (2.5" perimeter): 4 inch heat path on 4 mm glass is approximately R-6. Third, frame of window: R-13 for foam minus thermal bridging losses of structure R-10. Thus, the combined total thermal resistance of the overall window is approximately R-8 or higher, more preferably about R-10 or higher. The final R-value of the overall window is dependent on the height and width of the window, the thickness of the glass, the depth of the bite "B" on the VIG unit, and the extent of thermal bridging in the frame 30.

[0019] It is noted that large edge bites on a VIG unit can reduce high stresses imposed on a glazing due to extreme temperature differences between indoor and outdoor temperatures. This would reduce the likelihood of glass fracturing in extreme climates. Moreover, the outboard monolithic lite (3) may be used also to reduce the indoor to outdoor temperature difference. In addition, large edge bites on a VIG can reduce the relative area of the very cold glass (outer VIG pane) to the much warmer glass (indoor VIG pane). Furthermore, the stresses may be distributed more uniformly across the large edge area of the window unit.

[0020] While the invention has been described in connection with what is presently considered to be the most practical and preferred embodiment, it is to be understood that the invention is not to be limited to the disclosed embodiment, but on the contrary, is intended to cover various modifications and equivalent arrangements included within the spirit and scope of the appended claims.

**CLAIMS**

1. A window unit comprising:

an insulating frame in which both an inboard glass lite and an outboard glass lite are partially embedded, the inboard lite comprising a vacuum IG unit including first and second spaced apart glass sheets that are separated from one another via a gap that is a pressure less than atmospheric, and the outboard lite comprising a monolithic glass sheet spaced apart from the vacuum IG unit;

wherein the frame comprises insulating material that separates the outer surface of the vacuum IG unit from an inner surface of the monolithic glass sheet;

wherein along at least one of a top edge, a bottom edge, and/or a side edge of the window unit, the outer edge of the monolithic glass sheet is vertically offset from the outer edge of the vacuum IG unit so that the outer edge of the vacuum IG unit is closer to a periphery of the window unit than is the outer edge of the monolithic glass sheet;

wherein the first and second glass sheets have substantially the same height, the insulating material separates the surface of the vacuum IG unit closest to the monolithic glass sheet from the inner surface of the monolithic glass sheet, and wherein a gap between the inboard lite and the outboard lite is substantially at atmospheric pressure, so that the gap on one side of the second glass sheet provided between the first and second glass sheets is at a pressure less than atmospheric pressure, but the gap on the other side of the second glass sheet provided between the second glass sheet and the outboard lite is substantially at atmospheric pressure; and

wherein a total R-value of the window unit is above about R-8.

2. The window unit of claim 1, wherein a low-E coating is provided on the inner surface of the monolithic glass sheet.

3. The window unit of claim 1, wherein the frame comprises an outer portion which at least partially surrounds an insulating foam core, wherein at least part of the foam core is located between the vacuum IG unit and the monolithic glass sheet.

4. The window unit of claim 1, wherein a substantially L-shaped channel is defined in the frame, wherein a vertical channel portion of the substantially L-shaped channel receives part of the vacuum IG unit.
5. The window unit of claim 4, wherein a support member is provided at a bottom of the vertical channel portion, and a bottom of the vacuum IG unit rests on the support member.
6. The window unit of claim 1, wherein a substantially L-shaped channel is defined in the frame which receives part of the monolithic glass sheet.
7. The window unit of claim 1, wherein the frame has a bite (B) of from about one to three inches.
8. A window unit comprising:
  - an insulating frame in which a vacuum IG unit and a monolithic lite are provided, the vacuum IG unit including first and second spaced apart glass sheets that are separated from one another via a gap that is a pressure less than atmospheric, and the monolithic lite being spaced apart from the vacuum IG unit;
  - wherein the frame comprises insulating material that separates the vacuum IG unit from the monolithic lite
  - wherein a gap between the vacuum IG unit and the monolithic lite is substantially at atmospheric pressure, so that a gap immediately adjacent one side of an outer glass sheet of the vacuum IG unit is at a pressure less than atmospheric pressure, but another gap on the other side of the outer glass sheet of the vacuum IG unit is substantially at atmospheric pressure; and
  - wherein a total R-value of the window unit is above about R-8.
9. The window unit of claim 8, wherein along at least one of a top edge, a bottom edge, and/or a side edge of the window unit, the outer edge of the monolithic lite is vertically offset from the outer edge of the vacuum IG unit so that the outer edge of the vacuum IG unit is closer to a periphery of the window unit than is the outer edge of the monolithic lite.

10. The window unit of claim 9, wherein a low-E coating is provided on an interior surface of the monolithic lite, and wherein the monolithic lite is provided closer to an exterior of a building in which the window unit is located than is the vacuum IG unit.

11. The window unit of claim 8, wherein the frame comprises an outer portion which at least partially surrounds an insulating foam core, wherein at least part of the foam core is located between the vacuum IG unit and the monolithic lite.

12. The window unit of claim 8, wherein a substantially L-shaped channel is defined in the frame, wherein a vertical channel portion of the substantially L-shaped channel receives part of the vacuum IG unit.

13. The window unit of claim 12, wherein a support member is provided at a bottom of the vertical channel portion, and a bottom of the vacuum IG unit rests on the support member.

14. The window unit of claim 8, wherein a substantially L-shaped channel is defined in the frame which receives part of the monolithic lite.



