

(19) World Intellectual Property Organization  
International Bureau



(43) International Publication Date  
30 August 2001 (30.08.2001)

PCT

(10) International Publication Number  
**WO 01/63308 A1**

(51) International Patent Classification<sup>7</sup>: G01R 31/02

(21) International Application Number: PCT/US01/05430

(22) International Filing Date: 20 February 2001 (20.02.2001)

(25) Filing Language: English

(26) Publication Language: English

(30) Priority Data:  
60/184,851 25 February 2000 (25.02.2000) US  
09/637,527 10 August 2000 (10.08.2000) US

(71) Applicant (for all designated States except US): **CASCADE MICROTECH, INC.** [US/US]; 2430 N.W. 206th Avenue, Beaverton, OR 97006 (US).

(72) Inventors; and

(75) Inventors/Applicants (for US only): **TERVO, Paul, A.** [US/US]; 10000 N.E. 116th Circle, Vancouver, WA 98662 (US). **SMITH, Kenneth, R.** [US/US]; 7245 S.W. Ashdale Drive, Portland, OR 97223 (US). **COWAN, Clarence,**

E. [US/US]; 13710 N.E. Chehalem Drive, Newberg, OR 97132 (US). **DAUPHINAIS, Mike, P.** [US/US]; 17175 S.W. Blanton Street, Beaverton, OR 97007 (US). **KOXXY, Martin, J.** [US/US]; 3663 S.E. Roanoke Court, Hillsboro, OR 97123 (US).

(74) Agents: **RUSSELL, Kevin, L.** et al.; Chernoff, Vilhauer, McClung & Stenzel, LLP, 1600 ODS Tower, 601 S.W. Second Street, Portland, OR 97204-3157 (US).

(81) Designated States (national): AL, AM, AT, AU, AZ, BA, BB, BG, BR, BY, CA, CH, CN, CU, CZ, DE, DE (utility model), DK, EE, ES, FI, GB, GD, GE, GH, GM, HR, HU, ID, IL, IN, IS, JP, KE, KG, KP, KR, KZ, LC, LK, LR, LS, LT, LU, LV, MD, MG, MK, MN, MW, MX, NO, NZ, PL, PT, RO, RU, SD, SE, SG, SI, SK, SL, TJ, TM, TR, TT, UA, UG, US, UZ, VN, YU, ZW.

(84) Designated States (regional): ARIPO patent (GH, GM, KE, LS, MW, MZ, SD, SL, SZ, TZ, UG, ZW), Eurasian patent (AM, AZ, BY, KG, KZ, MD, RU, TJ, TM), European patent (AT, BE, CH, CY, DE, DK, ES, FI, FR, GB, GR, IE, IT, LU, MC, NL, PT, SE, TR), OAPI patent (BF, BJ, CF, CG, CI, CM, GA, GN, GW, ML, MR, NE, SN, TD, TG).

[Continued on next page]

(54) Title: MEMBRANE PROBING SYSTEM

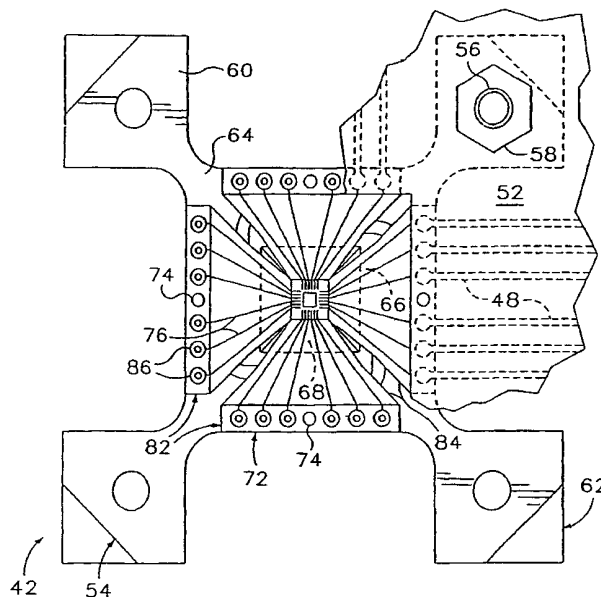

(57) Abstract: A membrane probing assembly (40) includes a probe card (52) with conductors supported thereon, wherein the conductors include at least a signal conductor located between a pair of spaced apart guard conductors. A membrane assembly (72) includes a membrane with contacts thereon, and supporting at least a signal conductor (280, 282) located between a pair of spaced apart guard conductors (284, 286). The guard conductors of the probe card (52) are electrically interconnected proximate the interconnection between the probe card (52) and the membrane assembly (72). The guard conductors of the membrane assembly are electrically interconnected proximate the interconnection between the probe card and the membrane assembly.



WO 01/63308 A1



**Published:**

- with international search report
- with amended claims

*For two-letter codes and other abbreviations, refer to the "Guidance Notes on Codes and Abbreviations" appearing at the beginning of each regular issue of the PCT Gazette.*

## MEMBRANE PROBING SYSTEM

## BACKGROUND OF THE INVENTION

The present invention relates to probe  
5 assemblies of the type commonly used for testing  
integrated circuits (IC).

The trend in electronic production has been  
toward increasingly smaller geometries particularly in  
integrated circuit technology wherein a very large number  
10 of discrete circuit elements are fabricated on a single  
substrate or "wafer." After fabrication, this wafer is  
divided into a number of rectangular-shaped chips or  
"dice" where each die presents a rectangular or other  
regular arrangement of metallized contact pads through  
15 which input/output connections are made. Although each  
die is eventually packaged separately, for efficiency  
sake, testing of the circuit formed on each die is pref-  
erably performed while the dies are still joined together  
on the wafer. One typical procedure is to support the  
20 wafer on a flat stage or "chuck" and to move the wafer in  
X, Y and Z directions relative to the head of the probing  
assembly so that the contacts on the probing assembly  
move from die to die for consecutive engagement with each  
die. Respective signal, power and ground lines are run  
25 to the probing assembly from the test instrumentation  
thus enabling each circuit to be sequentially connected  
to the test instrumentation.

One conventional type of probing assembly used  
for testing integrated circuits provides contacts that  
30 are configured as needle-like tips. These tips are  
mounted about a central opening formed in a probe card so  
as to radially converge inwardly and downwardly through  
the opening. When the wafer is raised beyond that point  
where the pads on the wafer first come into contact with  
35 these tips, the tips flex upwardly so as to skate for-  
wardly across their respective pads thereby removing  
oxide buildup on the pads.

The problem with this type of probing assembly is that the needle-like tips, due to their narrow geometry, exhibit high inductance so that signal distortion is large in high frequency measurements made through these tips. Also, these tips can act in the manner of a planing tool as they wipe across their respective pads, thereby leading to excessive pad damage. This problem is magnified to the extent that the probe tips bend out of shape during use or otherwise fail to terminate in a common plane which causes the more forward ones of the tips to bear down too heavily on their respective pads. Also, it is impractical to mount these tips at less than 100 micron center-to-center spacing or in a multi-row grid-like pattern so as to accommodate the pad arrangement of more modern, higher density dies. Also, this type of probing assembly has a scrub length of the needle tips of 25 microns or more, which increases the difficulty of staying within the allowed probing area.

In order to reduce inductive losses, decrease pad wear, and accommodate smaller device geometries, a second type of probing assembly has been developed that uses a flexible membrane structure for supporting the probing contacts. In this assembly, lead lines of well-defined geometry are formed on one or more plies of flexible insulative film, such as polyimide or MYLAR™. If separate plies are used, these plies are bonded together to form, for example, a multilayered transmission line structure. In the central portion of this flexible structure or membrane, each conductive line is terminated by a respective probing contact which is formed on, and projects outwardly from, an outer face of the membrane. These probing contacts are arranged in a predetermined pattern that matches the pattern of the device pads and typically are formed as upraised bumps for probing the flat surfaces conventionally defined by the pads. The inner face of the membrane is supported on a supporting

structure. This structure can take the form, for example, of a truncated pyramid, in which case the inner face of the center portion of the membrane is supported on the truncated end of the support while the marginal portions of the membrane are drawn away from the center portion at an angle thereto so as to clear any upright components that may surround the pads on the device.

With respect to the membrane probing assembly just described, excessive line inductance is eliminated by carefully selecting the geometry of the lead lines, and a photolithographic process is preferably used to enable some control over the size, spacing, and arrangement, of the probing contacts so as to accommodate higher density configurations. However, although several different forms of this probing assembly have been proposed, difficulties have been encountered in connection with this type of assembly in reducing pad wear and in achieving reliable clearing of the oxide layer from each of the device pads so as to ensure adequate electrical connection between the assembly and the device-under-test.

One conventional form of membrane probing assembly, for example, is exemplified by the device shown in Rath European Patent Pub. No. 259,163A2. This device has the central portion of the sheet-like membrane mounted directly against a rigid support. This rigid support, in turn, is connected by a resilient member comprising an elastomeric or rubber block to the main body of the assembly so that the membrane can tilt to match the tilt of the device. Huff U.S. Patent No. 4,918,383 shows a closely related device wherein radially extending leaf springs permit vertical axis movement of the rigid support while preventing it from tilting so that there is no slippage or "misalignment" of the contact bumps on the pads and further so that the entire membrane will shift slightly in the horizontal plane to

allow the contacts to "scrub" across their respective pads in order to clear surface oxides from these pads.

In respect to both of these devices, however, because of manufacturing tolerances, certain of the  
5 contact bumps are likely to be in a recessed position relative to their neighbors and these recessed bumps will not have a satisfactory opportunity to engage their pads since they will be drawn away from their pads by the action of their neighbors on the rigid support. Further-  
10 more, even when "scrub" movement is provided in the manner of Huff, the contacts will tend to frictionally cling to the device as they perform the scrubbing movement, that is, there will be a tendency for the pads of the device to move in unison with the contacts so as to  
15 negate the effect of the contact movement. Whether any scrubbing action actually occurs depends on how far the pads can move, which depends, in turn, on the degree of lateral play that exists as a result of normal tolerance between the respective bearing surfaces of the probe head  
20 and chuck. Hence this form of membrane probing assembly does not ensure reliable electrical connection between each contact and pad.

A second conventional form of membrane probing assembly is exemplified by the device shown in Barsotti  
25 European Patent Pub. No. 304,868A2. This device provides a flexible backing for the central or contact-carrying portion of the flexible membrane. In Barsotti, the membrane is directly backed by an elastomeric member and this member, in turn, is backed by a rigid support so  
30 that minor height variations between the contacts or pads can be accommodated. It is also possible to use positive-pressure air, negative-pressure air, liquid or an unbacked elastomer to provide flexible backing for the membrane, as shown in Gangroth U.S. Patent No. 4,649,339,  
35 Ardezzone U.S. Patent No. 4,636,772, Reed, Jr. et al. U.S. Patent No. 3,596,228 and Okubo et al. U.S. Patent No. 5,134,365, respectively. These alternative devices,

however, do not afford sufficient pressure between the probing contacts and the device pads to reliably penetrate the oxides that form on the pad surfaces.

In this second form of membrane probing assembly, as indicated in Okubo, the contacts may be limited to movement along the Z-axis in order to prevent slippage and resulting misalignment between the contacts and pads during engagement. Thus, in Barsotti, the rigid support underlying the elastomeric member is fixed in position although it is also possible to mount the support for Z-axis movement in the manner shown in Huff U.S. Patent No. 4,980,637. Pad damage is likely to occur with this type of design, however, because a certain amount of tilt is typically present between the contacts and the device, and those contacts angled closest to the device will ordinarily develop much higher contact pressures than those which are angled away. The same problem arises with the related assembly shown in European Patent Pub. No. 230,348A2 to Garretson, even though in the Garretson device the characteristic of the elastomeric member is such as to urge the contacts into lateral movement when those contacts are placed into pressing engagement with their pads. Yet another related assembly is shown in Evans U.S. Patent No. 4,975,638 which uses a pivotably mounted support for backing the elastomeric member so as to accommodate tilt between the contacts and the device. However, the Evans device is subject to the friction clinging problem already described insofar as the pads of the device are likely to cling to the contacts as the support pivots and causes the contacts to shift laterally.

Yet other forms of conventional membrane probing assemblies are shown in Crumly U.S. Patent No. 5,395,253, Barsotti et al. U.S. Patent No. 5,059,898 and Evans et al. U.S. Patent No. 4,975,638. In Crumly, the center portion of a stretchable membrane is resiliently biased to a fully stretched condition using a spring.

When the contacts engage their respective pads, the stretched center portion retracts against the spring to a partially relaxed condition so as to draw the contacts in radial scrub directions toward the center of the membrane. In Barsotti, each row of contacts is supported by the end of a respective L-shaped arm so that when the contacts in a row engage their respective pads, the corresponding arm flexes upwardly and causes the row of contacts to laterally scrub simultaneously across their respective pads. In both Crumly and Barsotti, however, if any tilt is present between the contacts and the device at the time of engagement, this tilt will cause the contacts angled closest to the device to scrub further than those angled further away. Moreover, the shorter contacts will be forced to move in their scrub directions before they have had the opportunity to engage their respective pads due to the controlling scrub action of their neighboring contacts. A further disadvantage of the Crumly device, in particular, is that the contacts nearer to the center of the membrane will scrub less than those nearer to the periphery so that scrub effectiveness will vary with contact position.

In Evans et al. U.S. Patent No. 5,355,079 each contact constitutes a spring metal finger, and each finger is mounted so as to extend in a cantilevered manner away from the underlying membrane at a predetermined angle relative to the membrane. A similar configuration is shown in Higgins U.S. Patent No. 5,521,518. It is difficult, however, to originally position these fingers so that they all terminate in a common plane, particularly if a high density pattern is required. Moreover, these fingers are easily bent out of position during use and cannot easily be rebent back to their original position. Hence, certain ones of the fingers are likely to touch down before other ones of the fingers, and scrub pressures and distances are likely to be different for different fingers. Nor, in Evans at



least, is there an adequate mechanism for tolerating a minor degree of tilt between the fingers and pads. Although Evans suggests roughening the surface of each finger to improve the quality of electrical connection, this roughening can cause undue abrasion and damage to the pad surfaces. Yet a further disadvantage of the contact fingers shown in both Evans and Higgins is that such fingers are subject to fatigue and failure after a relatively low number of "touchdowns" or duty cycles due to repeated bending and stressing.

Referring to FIG. 1, Cascade Microtech, Inc. of Beaverton, Oregon has developed a probe head 40 for mounting a membrane probing assembly 42. In order to measure the electrical performance of a particular die area 44 included on the silicon wafer 46, the high-speed digital lines 48 and/or shielded transmission lines 50 of the probe head are connected to the input/output ports of the test instrumentation by a suitable cable assembly, and the chuck 51 which supports the wafer is moved in mutually perpendicular X,Y,Z directions in order to bring the pads of the die area into pressing engagement with the contacts included on the lower contacting portion of the membrane probing assembly.

The probe head 40 includes a probe card 52 on which the data/signal lines 48 and 50 are arranged. Referring to FIGS. 2-3, the membrane probing assembly 42 includes a support element 54 formed of incompressible material such as a hard polymer. This element is detachably connected to the upper side of the probe card by four Allen screws 56 and corresponding nuts 58 (each screw passes through a respective attachment arm 60 of the support element, and a separate backing element 62 evenly distributes the clamping pressure of the screws over the entire back side of the supporting element). In accordance with this detachable connection, different probing assemblies having different contact arrangements

can be quickly substituted for each other as needed for probing different devices.

Referring to FIGS. 3-4, the support element 54 includes a rearward base portion 64 to which the attachment arms 60 are integrally joined. Also included on the support element 54 is a forward support or plunger 66 that projects outwardly from the flat base portion. This forward support has angled sides 68 that converge toward a flat support surface 70 so as to give the forward support the shape of a truncated pyramid. Referring also to FIG. 2, a flexible membrane assembly 72 is attached to the support after being aligned by means of alignment pins 74 included on the base portion. This flexible membrane assembly is formed by one or more plies of insulative sheeting such as KAPTON™ sold by E.I. Du Pont de Nemours or other polyimide film, and flexible conductive layers or strips are provided between or on these plies to form the data/signal lines 76.

When the support element 54 is mounted on the upper side of the probe card 52 as shown in FIG. 3, the forward support 66 protrudes through a central opening 78 in the probe card so as to present the contacts which are arranged on a central region 80 of the flexible membrane assembly in suitable position for pressing engagement with the pads of the device under test. Referring to FIG. 2, the membrane assembly includes radially extending arm segments 82 that are separated by inwardly curving edges 84 that give the assembly the shape of a formee cross, and these segments extend in an inclined manner along the angled sides 68 thereby clearing any upright components surrounding the pads. A series of contact pads 86 terminate the data/signal lines 76 so that when the support element is mounted, these pads electrically engage corresponding termination pads provided on the upper side of the probe card so that the data/signal lines 48 on the probe card are electrically connected to the contacts on the central region.

A feature of the probing assembly 42 is its capability for probing a somewhat dense arrangement of contact pads over a large number of contact cycles in a manner that provides generally reliable electrical  
5 connection between the contacts and pads in each cycle despite oxide buildup on the pads. This capability is a function of the construction of the support element 54, the flexible membrane assembly 72 and their manner of interconnection. In particular, the membrane assembly is  
10 so constructed and connected to the support element that the contacts on the membrane assembly preferably wipe or scrub, in a locally controlled manner, laterally across the pads when brought into pressing engagement with these pads. The preferred mechanism for producing this scrub-  
15 bing action is described in connection with the construction and interconnection of a preferred membrane assembly 72a as best depicted in FIGS. 6 and 7a-7b.

FIG. 6 shows an enlarged view of the central region 80a of the membrane assembly 72a. In this embodi-  
20 ment, the contacts 88 are arranged in a square-like pattern suitable for engagement with a square-like arrangement of pads. Referring also to FIG. 7a, which represents a sectional view taken along lines 7a-7a in FIG. 6, each contact comprises a relatively thick rigid  
25 beam 90 at one end of which is formed a rigid contact bump 92. The contact bump includes thereon a contacting portion 93 which comprises a nub of rhodium fused to the contact bump. Using electroplating, each beam is formed in an overlapping connection with the end of a flexible  
30 conductive trace 76a to form a joint therewith. This conductive trace in conjunction with a back-plane conductive layer 94 effectively provides a controlled impedance data/signal line to the contact because its dimensions are established using a photolithographic process. The  
35 backplane layer preferably includes openings therein to assist, for example, with gas venting during fabrication.

The membrane assembly is interconnected to the flat support surface 70 by an interposed elastomeric layer 98, which layer is coextensive with the support surface and can be formed by a silicone rubber compound such as ELMER'S STICK-ALL™ made by the Borden Company or Sylgard 182 by Dow Corning Corporation. This compound can be conveniently applied in a paste-like phase which hardens as it sets. The flat support surface, as previously mentioned, is made of incompressible material and is preferably a hard dielectric such as polysulfone or glass.

In accordance with the above-described construction, when one of the contacts 88 is brought into pressing engagement with a respective pad 100, as indicated in FIG. 7b, the resulting off-center force on the rigid beam 90 and bump 92 structure causes the beam to pivot or tilt against the elastic recovery force provided by the elastomeric pad 98. This tilting motion is localized in the sense that a forward portion 102 of the beam moves a greater distance toward the flat support surface 70 than a rearward portion 104 of the same beam. The effect is such as to drive the contact into lateral scrubbing movement across the pad as is indicated in FIG. 7b with a dashed-line and solid-line representation showing the beginning and ending positions, respectively, of the contact on the pad. In this fashion, the insulative oxide buildup on each pad is removed so as to ensure adequate contact-to-pad electrical connections.

FIG. 8 shows, in dashed line view, the relative positions of the contact 88 and pad 100 at the moment of initial engagement or touchdown and, in solid-line view, these same elements after "overtravel" of the pad by a distance 106 in a vertical direction directly toward the flat support surface 70. As indicated, the distance 108 of lateral scrubbing movement is directly dependent on the vertical deflection of the contact 88 or, equivalently, on the overtravel distance 106 moved by the pad

100. Hence, since the overtravel distance for each contact on the central region 80a will be substantially the same (with differences arising from variations in contact height), the distance of lateral scrubbing movement by each contact on the central region will be substantially uniform and will not, in particular, be affected by the relative position of each contact on the central region.

Because the elastomeric layer 98 is backed by the incompressible support surface 70, the elastomeric layer exerts a recovery force on each tilting beam 90 and thus each contact 93 to maintain contact-to-pad pressure during scrubbing. At the same time, the elastomeric layer accommodates some height variations between the respective contacts. Thus, referring to FIG 9a, when a relatively shorter contact 88a is situated between an immediately adjacent pair of relatively taller contacts 88b and these taller contacts are brought into engagement with their respective pads, then, as indicated in FIG. 9b, deformation by the elastomeric layer allows the smaller contact to be brought into engagement with its pad after some further overtravel by the pads. It will be noted, in this example, that the tilting action of each contact is locally controlled, and the larger contacts are able, in particular, to tilt independently of the smaller contact so that the smaller contact is not urged into lateral movement until it has actually touched down on its pad.

Referring to FIGS. 10 and 11, the electroplating process to construct such a beam structure, as schematically shown in FIG. 8, includes the incompressible material 68 defining the support surface 70 and the substrate material attached thereon, such as the elastomeric layer 98. Using a flex circuit construction technique, the flexible conductive trace 76a is then patterned on a sacrificial substrate. Next, a polyimide layer 77 is patterned to cover the entire surface of the

sacrificial substrate and of the traces 76a, except for the desired location of the beams 90 on a portion of the traces 76a. The beams 90 are then electroplated within the openings in the polyimide layer 77. Thereafter, a layer of photoresist 79 is patterned on both the surface of the polyimide 77 and beams 90 to leave openings for the desired location of the contact bumps 92. The contact bumps 92 are then electroplated within the openings in the photoresist layer 79. The photoresist layer 79 is removed and a thicker photoresist layer 81 is patterned to cover the exposed surfaces, except for the desired locations for the contacting portions 93. The contacting portions 93 are then electroplated within the openings in the photoresist layer 81. The photoresist layer 81 is then removed. The sacrificial substrate layer is removed and the remaining layers are attached to the elastomeric layer 98. The resulting beams 90, contact bumps 92, and contacting portions 93, as more accurately illustrated in FIG. 12, provides the independent tilting and scrubbing functions of the device.

Another suitable technique of the construction of a membrane probe is disclosed in co-pending U.S. Patent Application, Serial Number 09/115,571, incorporated by reference herein. However, for the inventions described herein, the present inventors have no preference as to the particular construction of the contacting portion of the membrane assembly nor the general structure of the membrane or membrane assembly itself.

While providing an improved technique for effective scrubbing action is significant, the present inventors determined that excessive noise still remains in the signals sensed by the measurement device.

## SUMMARY OF THE INVENTION

The present invention overcomes the  
aforementioned drawbacks of the prior art by providing a  
membrane probing assembly with a probe card that includes  
5 conductors supported thereon, wherein the conductors  
include at least a signal conductor located between a  
pair of spaced apart guard conductors. A membrane  
assembly includes a membrane with contacts thereon, and  
supporting at least a signal conductor located between a  
10 pair of spaced apart guard conductors. The guard  
conductors of the probe card are electrically  
interconnected proximate the interconnection between the  
probe card and the membrane assembly. The guard  
conductors of the membrane assembly are electrically  
15 interconnected proximate the interconnection between the  
probe card and the membrane assembly.

The foregoing and other objectives, features,  
and advantages of the invention will be more readily  
understood upon consideration of the following detailed  
20 description of the invention, taken in conjunction with  
the accompanying drawings.

## BRIEF DESCRIPTION OF THE SEVERAL VIEWS OF THE DRAWINGS

FIG. 1 is a perspective view of a membrane  
25 probing assembly bolted to a probe head and a wafer  
supported on a chuck in suitable position for probing by  
this assembly.

FIG. 2 is a bottom elevational view showing  
various parts of the probing assembly of FIG. 1, includ-  
30 ing a support element and flexible membrane assembly, and  
a fragmentary view of a probe card having data/signal  
lines connected with corresponding lines on the membrane  
assembly.

FIG. 3 is a side elevational view of the  
35 membrane probing assembly of FIG. 1 where a portion of  
the membrane assembly has been cut away to expose hidden  
portions of the support element.

FIG. 4 is a top elevational view of an exemplary support element.

FIGS. 5a-5b are schematic side elevational views illustrating how the support element and membrane assembly are capable of tilting to match the orientation of the device under test.

FIG. 6 is an enlarged top elevational view of the central region of the construction of the membrane assembly of FIG. 2.

FIGS. 7a-7b are sectional views taken along lines 7a-7a in FIG. 6 first showing a contact before touchdown and then showing the same contact after touchdown and scrub movement across its respective pad.

FIG. 8 is a schematic side view showing, in dashed-line representation, the contact of FIGS. 7a-7b at the moment of initial touchdown and, in solid-line representation, the same contact after further vertical overtravel by the pad.

FIGS. 9a and 9b illustrate the deformation of the elastomeric layer to bring the contacts into contact with its pad.

FIG. 10 is a longitudinal sectional view of the device of FIG. 8.

FIG. 11 is a cross sectional view of the device of FIG. 8.

FIG. 12 is a more accurate pictorial view of the device shown in FIGS. 10 and 11.

FIG. 13 is partial plan view of a membrane assembly and a probe card.

FIG. 14A is a partial pictorial view of the traces of a membrane assembly.

FIG. 14B is a partial plan view of the interconnection between a membrane assembly and a probe card.

FIG. 14C is a partial sectional side view of the interconnection between the membrane assembly and the probe card of FIG. 14B.



FIG. 15 is a partial sectional view of a probe card illustrating the leakage currents from the end portions of the signal and guard conductors.

FIG. 16 is a partial sectional view of a probe card illustrating the interconnecting of a pair of guard conductors together with a signal conductor therebetween.

FIG. 17 is a partial plan view of a portion of a probe card illustrating power conductors, signal conductors, force conductors, sense conductors, removed interconnecting portions, and interconnected guard conductors.

FIG. 18 is a partial plan view of a portion of a membrane assembly illustrating signal conductors, force conductors, sense conductors, and interconnected guard conductors.

FIG. 19 is a partial plan view of a probe card and a membrane assembly suitable for a Kelvin connection.

FIG. 20 is a partial plan view of a probe card illustrating different geometries for the interconnection to a membrane assembly.

FIG. 21 is a partial plan view of a membrane assembly illustrating a guard conductor looping around a respective probing device.

FIG. 22 is a plan view of a "pogo-pin" probe card constructed in accordance with aspects of the present invention, where the connections to the probe card are normally electrical contacts from a probe ahead positioned above the probe card.

### 30 DETAILED DESCRIPTION OF THE PREFERRED EMBODIMENT

With particular regard to probe cards that are specially adapted for use in measuring ultra-low currents, probe card designers have been concerned with developing techniques for controlling (e.g., minimizing) leakage currents. Unwanted currents that flow into a particular cable (or conductor) from surrounding cables (or conductors) may distort the current measured in that

particular cable (or conductor). For a given potential difference between two spaced apart conductors, the amount of leakage current that will flow between them will vary depending upon the volume resistivity of the insulating material that separates the conductors. In other words, if a relatively lower-resistance insulator is used, this will result in a relatively higher leakage current. Thus, a designer of low-current probe cards will normally avoid the use of rubber-insulated single-core wires on a glass-epoxy board since rubber and glass-epoxy materials are known to be relatively low-resistance insulators through which relatively large leakage currents can flow.

One technique that has been used for suppressing inter-channel leakage currents is positioning the signal conductor between a pair of guard conductors, where each guard conductor is maintained at the same potential as the signal conductor by a feedback circuit in the output channel of the test instrument. Because the voltage potentials of the guard conductors and the respective signal conductor are made to substantially track each other, negligible leakage current will flow from the signal conductor to the corresponding guard conductors. Although leakage current can still flow between different sets of guard conductors, this is typically not a problem because the guard conductors, unlike the signal conductors, are at low impedance. By using this guarding technique, significant improvements may be realized in the low-level current measuring capability of certain probe card designs by reducing the capacitance between signal and guard, and increasing the resistance between signal and guard.

To further improve low-current measurement capability, the membrane assembly is constructed so as to likewise minimize leakage currents between the individual probing devices. Typically, this minimization involves the selection of membrane materials and likewise

providing limited guarding of the signal conductor by a pair of guard conductors to a location proximate the probing device. Referring to FIG. 13, to provide the guarded path to a location proximate the probing devices each respective signal conductor 200 is located between a pair of respective guard conductors 202, 204 on the probe card 52, and the membrane assembly 72 likewise has a matching set of signal conductors 206 and guard conductors 208, 210. It is thought that this arrangement provides continuous sets of signal conductor/guard conductors to a location proximate the probing devices in a manner to achieve low leakage along nearly its entire length. However, even with the guarding of the signal conductors on the probe card 52 and the membrane assembly 72, the leakage current levels remain unacceptable for low-current low-noise measurements.

In other probe card designs, efforts have been directed toward systematically eliminating low-resistance leakage paths within the probe card and toward designing extensive and elaborate guarding structures to surround the signal conductors along the signal path. For example, in one design, the entire glass-epoxy main board is replaced with a board of ceramic material which presents a relatively high resistance to leakage currents. However, the ceramic material used in these newer designs is relatively more expensive than the glass-epoxy material it replaces. Another problem with ceramic materials is that they are relatively susceptible to the absorption of surface contaminants such as can be deposited by the skin during handling of the probe card. These contaminants can decrease the surface resistivity of the ceramic material to a sufficient extent as to produce a substantial increase in the leakage current levels. In addition, the more extensive and elaborate guarding structures that are used in these newer designs has contributed to a large increase in design and assembly costs.

It should be noted that there are other factors unrelated to design that can influence whether or not the potential of a particular probe card for measuring low-level currents will be fully realized. For example, if less special care is taken in assembling the probe card, it is possible for surface contaminants, such as oils and salts from the skin or residues left by solder flux, to contaminate the surface of the card and to degrade its performance (due to their ionic character, such contaminants can produce undesirable characteristics). Furthermore, even assuming that the card is designed and assembled properly, the card may not be suitably connected to the test instrument or the instrument may not be properly calibrated so as to completely null out, for example, the effects of voltage and current offsets. The probe card or the interconnecting lines can serve as pickup sites for ac fields, which ac fields can be rectified by the input circuit of the test instrument so as to cause errors in the indicated dc values. Thus, it is necessary to employ proper shielding procedures for (1) the probe card, (2) the interconnecting lines, and (3) the test instrument in order to shield out these field disturbances. Due to these factors, when a new probe card design is being tested, it can be extremely difficult to isolate the causes of undesirable background current in the new design due to numerous and possibly interacting factors that may be responsible.

The present inventors reconsidered a seemingly improbable source of noise, namely, the interconnection between the probe card 52 and the membrane assembly 72, which from initial considerations would appear to be effective at providing a guarded signal path to the probe device because of the "continuous" signal path upon interconnection. However, upon further consideration the present inventors determined that there is in fact significant unguarded and/or unshielded leakage paths existing in the region proximate the interconnection.

Referring to FIG. 14A, each conductive path of the membrane is normally encapsulated within at least one layer of material (FIG. 14A illustrates multiple conductive paths without additional membrane materials).

5 This provides a structure for routing conductive paths, such as the signal and guard conductors, to a location proximate the probing device without being on the exterior (lower surface) of the membrane assembly which may result in inadvertent contact with the device under

10 test. Referring to FIGS. 14B-14C, the signal and guard lines are actually interconnected between the probe card 52 and the membrane assembly 72 by conductive structures 220 that pass through the outer layer 222 of the membrane assembly 72 to the interior conductive paths 206, 208,

15 210 of the membrane assembly 72. To form the electrical connection, the probe card 52 and membrane assembly 72 are mechanically aligned, and accordingly respective conductive structures 220 of the membrane assembly 72 are interconnected with the conductors 200, 202, 204 of the

20 probe card 52. It is normally undesirable for the membrane assembly 72 interconnection to electrically connect at the absolute end of the conductors 200, 202, 204 (e.g., signal conductor and guard conductors) of the probe card 52 because then the tolerances for the

25 interconnection would be extremely small, requiring nearly perfect alignment and extremely accurate fabrication. Accordingly, normally the signal and guard conductors supported by the probe card 52 extend beyond the region of electrical interconnection.

30 After further consideration, the present inventors came the realization that this extension of the signal and/or guard conductors beyond the location of electrical connection results in significant additional leakage paths. Referring to FIG. 15, the region 216

35 beyond the end of the guard conductors provides for surface leakage paths 218, which are primarily DC in nature with the characteristic of an added resistance

between the respective conductive paths. This surface leakage path from a signal conductor around the end of the adjacent guard conductors reduces the accuracy of measurements by increasing the leakage currents. Also, 5 the present inventors likewise realized that the region 216 beyond the end of the guard conductors provides for a bulk leakage path, which is primarily AC (e.g., not DC) in nature with the characteristic of an added capacitance, between the signal conductor and the 10 conductors beyond the adjacent guard conductors. This bulk leakage path from the signal conductor around the end of the adjacent guard conductors reduces the accuracy of measurements by increasing the leakage currents. It is to be noted that the guard conductors, in effect, 15 impose a guard voltage into the bulk of the probe card in a region generally underneath the respective guard conductor. This reduces the bulk capacitive leakage currents from the interposed signal conductor in regions with an adjacent guard conductor.

20 In many embodiments, the opening 230 into which the membrane assembly 72 is supported includes a conductive surface 232 therein (e.g., guard, shield, ground) to further isolate the membrane assembly 72 from the probe card 52. Unfortunately, the conductive surface 25 232 results in significant fringe fields 234 (on the surface and in the bulk of the probe card 52) at the end of the signal conductors 200 and guard conductors 202, 204. These fringe fields 234 appear to the measuring device as an additional parallel capacitance and 30 resistance. This fringe leakage path at the end of the guard and signal conductors 200, 202, 204 reduces the accuracy of measurements by increasing the leakage currents. The cumulative result of the additional bulk leakage currents, additional surface leakage currents, 35 and additional fringe capacitance and resistance (leakage currents), appears to the measuring device as a capacitance and resistance lumped together with the

measurements of the actual device under test. It is difficult, if not nearly impossible, to calibrate such additional leakage currents out of any measurements so that the true measurement of the device under test is  
5 obtained. Further, the additional capacitance results in an increase in the settling time of signals thereby increasing the time required to obtain a set of accurate measurements.

It is desirable to maximize the number of  
10 interconnections available between the probe card 52 and the membrane assembly 72 in order to provide the capability of probing an increasingly greater number of devices under test. While increasing the size of the membrane assembly 72 to provide a greater circumferential  
15 edge may be employed, it remains desirable to limit the size of the membrane assembly 72 to minimize the length of the conductive paths to reduce leakage currents.

To increase the number of interconnections available between the membrane assembly 72 and the probe  
20 card 52, the width of the conductors of the membrane assembly 72 and the probe card 52 may be decreased together with the spacing between the conductors. While decreasing the size of the conductor increases the number of interconnections for a given circumferential edge,  
25 this unfortunately results in an increased difficulty of aligning the respective conductive traces together. Further, the greater density increases the manufacturing expense of the device.

In general, the membrane assembly 72 is  
30 suitable for a higher density of conductive paths than the probe card 52. Accordingly, the initial limit to the number of interconnects is the ability to fabricate an increasingly greater number of conductive traces on the probe card 52.

35 Referring to FIG. 16 the present inventors came to the realization that the preferred solution to overcome the aforementioned drawbacks of the presently

accepted techniques is to interconnect the guard  
conductors around the end of the signal conductor, in  
contrast to the apparent solution of merely decreasing  
the feature size of the interconnects. The  
5 interconnecting portion 240 for each respective pair of  
guard conductors (effectively one electrical conductor)  
is preferably on the same plane, such as the top surface  
of the probe card 52, together with the guard conductors  
and signal conductors. The interconnecting portion 240  
10 reduces the surface leakage path from the signal  
conductor by interposing a guarded path around the end of  
the signal conductor. In addition, the interconnecting  
portion 240 likewise decreases the bulk leakage path from  
a signal conductor by imposing a guard voltage in a  
15 region of the bulk of the probe card completely enclosing  
the end of the signal conductor. Also, the fringe  
leakage path to the central conductive surface 232 from  
the end of the signal conductor is substantially reduced,  
or otherwise eliminated, by providing the guarded  
20 interconnecting portion 240 around the end of the signal  
conductor. Reducing the leakage currents by including  
the additional interconnecting guard portion 240 results  
in the measurements made from the measuring device to be  
more accurate because less leakage currents are  
25 erroneously included in the measurements. In addition, a  
decrease in the settling time of the signals is achieved  
which reduces the time required to obtain a set of  
accurate measurements. One or more of the aforementioned  
drawbacks and/or advantages may be present and/or  
30 achieved depending upon the particular device and  
implementation.

With the interconnecting portion 240  
electrically interconnecting together a pair of guard  
conductors 202, 204 another benefit is more achievable,  
35 namely, increasing the number of potential  
interconnections, without necessarily changing the size  
of the membrane assembly 72, without necessarily changing



the geometry of the individual conductors, and without necessarily decreasing the spacing between adjacent conductors. Referring to FIG. 17, the contacting region 250 for the contacts 220 of the membrane assembly 72 on the probe card 52 are provided on at least one side of the interconnected guard conductor 202, 204, 240. This permits easier alignment of the membrane assembly 72 and the probe card 52. The width of the guard conductor on the side generally opposite the contacting region may be considerably thinner because there is no contact by the membrane assembly 72 with that portion of the guard conductor. The different widths of the guard conductors proximate the end of the signal conductor permits a greater density of conductors to be achieved, if desired, without decreasing the mechanical tolerances required. A pair of contacts (one on either side of the signal conductor) may be used, if desired. As a result, the density of the interconnect between the probe card 52 and the membrane assembly 72 is closer to the capability of the membrane assembly 72.

Referring to FIG. 18, to provide a single contact between the pair of guard conductors on the probe card 52 and a respective pair of guard conductors of the membrane assembly 72, the guard conductors of the membrane assembly 72 preferably include an interconnecting guard portion 260 with the interdisposed signal conductor, in a manner similar to the interconnecting guard portion 240. The interconnecting membrane guard portion 260 provides many of the same advantages as described above with respect to the interconnecting probe guard portion 240. By including the interconnecting membrane guard portion 260, only a single conductive structure 220 needs to be provided between the membrane assembly 72 and the probe card 52 for each set of guard conductors.

Ideally in a two lead conductor system a "true Kelvin" connection is constructed. This involves using

what is generally referred to as a force signal and a sense signal. The signal conductor from one of the two conductors is considered the force conductor, while the signal conductor from the other of the two conductors is considered the sense conductor. The force conductor is brought into contact with a test pad on the wafer. The force conductor is a low impedance connection, so a current is forced through the force conductor for testing purposes. The sense conductor is a high impedance connection and is also brought into contact with the same test pad (or a different test pad) on the wafer, preferably in close proximity to the sense conductor, in order to sense the voltage. As such the current versus voltage characteristics of the test device can be obtained using the force and sense conductors.

Referring to FIG. 19, one potential technique to achieve a Kelvin connection with the membrane probing system is to design the probe card 52 to include multiple sets of a force conductor, a sense conductor, and a corresponding pair of guard connectors on opposing sides of the force/sense conductors (preferably with the interconnection portion). The membrane assembly 72 likewise includes corresponding sets of a force conductor, a sense conductor, and guard conductors (preferably with the interconnecting portion). This provides a potential technique for achieving a Kelvin connection but unfortunately this wastes interconnection space on the probe card 52 in the event that a Kelvin connection for any particular device under test is not necessary. Alternatively, the probe card 52 may be redesigned for each membrane probing assembly, which is typically unique for each application. However, redesigning the probe card 52 for each application is expensive and not generally an acceptable solution.

While considering how to maintain one or more standard probe cards 52, together with providing Kelvin connections for each line, the present inventors

initially observed that the probe card 52 has more available surface area for routing the conductors further from the interconnection between the probe card 52 and the membrane assembly 72. With the additional surface area at regions not proximate the interconnection between the probe card 52 and the membrane assembly 72, a pair of conductive traces 280, 282 are easily routed, the pair being located between a pair of guard conductors 284, 286, to a location generally proximate the interconnection (see FIG. 17). For non-Kelvin measurements, one of the conductors may be used as the signal line with the remaining interconnected conductor not used. If desired, the interconnection 270 between the two interconnected signal conductors may be removed (open-circuited) for low noise measurements. However, with the two signal conductors (e.g. force and sense) normally interconnected it is a simple matter to break the interconnection 270 by removing a portion of conductors at region 290. In the event of "quasi-Kelvin" connections, the interconnection portion may be maintained and one of the pair of conductors 280, 282 would be used as a force conductor and the other conductor of the pair would be used as a sense conductor. Quasi-Kelvin connections are generally formed by the interconnection of a sense conductor and a force conductor at a point before the device under test.

To accomplish effective probing with the membrane assembly 72, typically low impedance power conductors 300 are provided on the probe card 52 to supply power to the probing devices of the membrane assembly 72. The present inventors determined that the interconnection 270 between the pair of conductors may be removed and the force conductor 280 may be jumpered with a wire bond 302 (or any other suitable technique) to an unused power conductor on the probe card 52. Each of the power conductors 300 on the probe card 52 are preferably conductive members within the bulk of the probe card 52,

electrically connected to the surface of the probe card 52 by using a set of vias 304, 306. Each power conductor is routed to a location proximate the interconnection between the probe card 52 and the membrane assembly 72.

5 The power conductor is normally a low impedance conductor. Because the force conductor is a low-impedance connection designed to carry significant current it is preferable to locate the force conductor outside of the guards 284, 286 of its corresponding sense  
10 conductor. In addition, because the force conductor is a low-impedance path carrying significant (non-negligible) current levels it does not necessarily require the guarding provided by the guard conductors 284, 286 on opposing sides of the sense conductor 282.

15 The power conductors, to which force conductors may be interconnected with, are preferably routed within the bulk of the probe card 52 in a region directly underneath the corresponding sense conductor. The  
20 conductive power conductor provides additional protection for the sense conductor to minimize leakage currents. Alternatively, the power conductor may be routed on the top surface (or bottom surface) of the probe card, if desired.

The power conductor is preferably routed to a  
25 point "interior" to the end of the corresponding signal conductor using a "via" 306 to the upper surface of the probe card 52. Accordingly, the power conductor is available at a location suitable for interconnection to the membrane assembly 72, if desired, while likewise  
30 being available for interconnection as a force conductor. In this manner, the same power conductor may be used to provide power to the device under test, while likewise providing a force connection, both of which in a manner that maintains the density of the interconnection of the  
35 interface between the probe card 52 and the membrane assembly 72. The actual use of the power conductors

depends on the application and the particular design of the membrane assembly 72.

Another technique suitable to provide a greater density of interconnects, and their corresponding  
5 interconnecting regions (normally having a greater surface area for contact to the membrane assembly 72) is to align the interconnects of the probe card 52 in a non-linear fashion (e.g., some closer and some farther from the edge of the probe card 52) around the circumference  
10 of the membrane assembly 72, as shown in FIG. 20. A further technique suitable to provide a greater density of interconnects, is to align the interconnecting regions in an overlapping manner with respect to a direction perpendicular to the adjacent membrane assembly 72. The  
15 membrane assembly 72 would likewise have corresponding structures suitable to interconnect to the two-dimensional structure of the conductors of the probe card 52.

The present inventors came to the realization  
20 that the membrane assembly is susceptible to absorption of moisture which increases the leakage currents within the membrane assembly. Referring to FIG. 21, another structure suitable to reduce leakage currents for the probing devices is shown. Preferably, the guarded  
25 conductors 310 of the membrane assembly 72 encircle the end of the probing device 312, with the signal conductor connected thereto 314. Preferably, the guarded conductors 310 are within the bulk of the membrane assembly 72 to prevent their inadvertent contact with the  
30 device under test. Providing the guarded probing devices significantly reduces the effects of leakage currents between the probing devices, especially due to the effects of humidity. However, the present inventors determined that the surface leakage currents between  
35 adjacent probing devices may be reduced by removing at least a portion of the membrane material (dielectric) 316 in a location proximate a portion of the guard conductors

310 and between the probing devices 312. In this manner, a portion of the guard conductor 310 will be exposed to the surface, albeit somewhat recessed from the surface of the membrane assembly 72, thereby impeding the passage of surface leakage between probing devices 312.

Referring to FIG. 22, in one embodiment of the present invention a pogo pin probe card includes guarded signal paths and is suitable for receiving a pogo pin probe head for connection thereto.

The terms and expressions which have been employed in the foregoing specification are used therein as terms of description and not of limitation, and there is no intention, in the use of such terms and expressions, of excluding equivalents of the features shown and described or portions thereof, it being recognized that the scope of the invention is defined and limited only by the claims which follow.

## CLAIM

- 5
- 10
- 15
- 20
1. A membrane probing assembly comprising:
    - (a) a probe card with conductors supported thereon, wherein said conductors include at least a signal conductor located between a pair of spaced apart guard conductors;
    - (b) a membrane assembly including a membrane with contacts thereon, and supporting at least a signal conductor located between a pair of spaced apart guard conductors;
    - (c) said guard conductors of said probe card are electrically interconnected proximate the interconnection between said probe card and said membrane assembly; and
    - (d) said guard conductors of said membrane assembly are electrically interconnected proximate the interconnection between said probe card and said membrane assembly.

## AMENDED CLAIMS

[received by the International Bureau on 6 June 2001 (06.06.01);  
original claim 1 replaced by new claims 1-37 (6 pages)]

1. A probing device for probing an electrical device comprising:
  - (a) a first support;
  - (b) a membrane in overlying relationship to said first support;
  - (c) a plurality of first elongate conductors supported by said membrane;
  - (d) a plurality of contacts supported by said membrane, each of said contacts electrically connected to at least a respective one of said first conductors;
  - (e) a second support suitable to support said first support thereon for probing said electrical device;
  - (f) a second elongate conductor having a first end supported by said second support;
  - (g) a third elongate conductor spaced apart from said second elongate conductor;
  - (h) a fourth elongate conductor spaced apart from said second elongate conductor, wherein said second conductor is located between said third conductor and said fourth conductor; and
  - (i) an interconnecting conductor electrically interconnecting said third conductor and said fourth conductor at a location proximate said first end of said second elongate conductor.
  
2. A probing device for probing an electrical device comprising:
  - (a) a first support;
  - (b) a membrane in overlying relationship to said first support;
  - (c) a plurality of first elongate conductors supported by said membrane;
  - (d) a plurality of contacts supported by said membrane, each of said contacts electrically connected to at least a respective one of said first conductors;
  - (e) a second support suitable to support said first support thereon for probing said electrical device;
  - (f) a second elongate conductor having a first end supported by said second support;
  - (g) a third elongate conductor spaced apart from said second elongate conductor;
  - (h) a fourth elongate conductor spaced apart from said second elongate conductor, wherein said second conductor is located between said third conductor and said fourth conductor; and
  - (i) an interconnecting conductor electrically interconnecting said third conductor and said fourth conductor at a location beyond said first end of said second elongate conductor.
  
3. The probing device of claim 2 wherein said interconnecting conductor is substantially coplanar with said third conductor and said fourth conductor.



4. The probing device of claim 2 wherein said interconnecting conductor is substantially coplanar with said second conductor.
5. The probing device of claim 2 wherein said second conductor provides a test signal.
6. The probing device of claim 5 wherein said third conductor provides a guard signal.
7. The probing device of claim 1 wherein said fourth elongate conductor has a first surface area in a region proximate to said first end of said second elongate conductor greater than a second surface area of said third elongate conductor in a region proximate to said first end of said second elongate conductor.
8. A probing device for probing an electrical device comprising:
  - (a) a first support;
  - (b) a membrane in overlying relationship to said first support;
  - (c) a plurality of first elongate conductors supported by said membrane;
  - (d) a plurality of contacts supported by said membrane, each of said contacts electrically connected to at least a respective one of said first conductors;
  - (e) a second support suitable to support said first support thereon for probing said electrical device;
  - (f) a second elongate conductor having a first end supported by said second support;
  - (g) a third elongate conductor spaced apart from said second elongate conductor, wherein said second conductor is located between said third conductor and said fourth conductor;
  - (h) a fourth elongate conductor spaced apart from said second elongate conductor, said fourth elongate conductor having a first surface area in a region proximate to said first end of said second elongate conductor greater than a second surface area of said third elongate conductor in a region proximate to said first end of said second elongate conductor.
9. The probing device of claim 8 wherein said first surface area has a maximum width greater than a maximum width of said second surface area.
10. The probing device of claim 8 further comprising an interconnecting conductor electrically interconnecting said third conductor and said fourth conductor at a location beyond said first end of said second elongate conductor.

11. The probing device of claim 10 wherein said interconnecting conductor is substantially coplanar with said third conductor and said fourth conductor.
12. The probing device of claim 11 wherein said interconnecting conductor is substantially coplanar with said second conductor.
13. The probing device of claim 8 wherein said second conductor provides a test signal.
14. The probing device of claim 8 wherein said third conductor provides a guard signal.
15. A probing device for probing an electrical device comprising:
  - (a) a first support;
  - (b) a membrane in overlying relationship to said first support;
  - (c) a plurality of first elongate conductors supported by said membrane;
  - (d) a plurality of contacts supported by said membrane, each of said contacts electrically connected to at least a respective one of said first conductors;
  - (e) a first one of said first elongate conductors having a first end;
  - (f) a second one of said first elongate conductors spaced apart from said first one;
  - (g) a third one of said first elongate conductors spaced apart from said first one, wherein said first one is located between said second one and said third one; and
  - (h) a first interconnecting conductor electrically interconnecting said second one and said third one at a location beyond said first end of said first one.
16. The probing device of claim 15 further comprising:
  - (a) a second support suitable to support said first support thereon for probing said electrical device;
  - (b) a second elongate conductor having a first end supported by said second support;
  - (c) a third elongate conductor spaced apart from said second elongate conductor;
  - (d) a fourth elongate conductor spaced apart from said second elongate conductor, wherein said second conductor is located between said third conductor and said fourth conductor; and
  - (e) a second interconnecting conductor electrically interconnecting said third conductor and said fourth conductor at a location beyond said first end of said second elongate conductor.

17. The probing device of claim 16 wherein said second interconnecting conductor is substantially coplanar with said third conductor and said fourth conductor.
18. The probing device of claim 16 wherein said second interconnecting conductor is substantially coplanar with said second conductor.
19. The probing device of claim 16 wherein said second conductor provides a test signal.
20. The probing device of claim 19 wherein said third conductor provides a guard signal.
21. The probing device of claim 16 wherein said fourth elongate conductor has a first surface area in a region proximate to said first end of said second elongate conductor greater than a second surface area of said third elongate conductor in a region proximate to said first end of said second elongate conductor.
22. The probing device of claim 15 wherein said first interconnecting conductor is substantially coplanar with said second one and said third one.
23. The probing device of claim 15 wherein said second interconnecting conductor is substantially coplanar with said first one.
24. The probing device of claim 15 wherein said first one provides a test signal.
25. The probing device of claim 24 wherein said second one provides a guard signal.
26. A probing device for probing an electrical device comprising:
  - (a) a first support:
  - (b) a membrane in overlying relationship to said first support:
  - (c) a plurality of first elongate conductors supported by said membrane:
  - (d) a plurality of contacts supported by said membrane, each of said contacts electrically connected to at least a respective one of said first conductors:
  - (e) a second support suitable to support said first support thereon for probing said electrical device:
  - (f) a second elongate conductor having a first end supported by said second support:
  - (g) a fifth elongate conductor having a first end supported by said second support:

- (h) a third elongate conductor spaced apart from said second elongate conductor;
  - (i) a fourth elongate conductor spaced apart from said second elongate conductor, wherein said second conductor and said fifth conductor are located between said third conductor and fourth conductor; and
  - (j) a first interconnecting conductor electrically interconnecting said third conductor and said fourth conductor at a location beyond said first end of said second elongate conductor and said first end of said fifth conductor.
27. The probing device of claim 26 for probing an electrical device comprising:
- (a) a first one of said first elongate conductors having a first end;
  - (b) a second one of said first elongate conductors having a first end;
  - (c) a fourth one of said first elongate conductors spaced apart from said first one;
  - (d) a third one of said first elongate conductors spaced apart from said first one, wherein said first third and said fourth one are located between said second one and said first one; and
  - (e) a second interconnecting conductor electrically interconnecting said third one and said fourth one at a location beyond said first end of said first one and said first end of said second one.
28. The probing device of claim 26 wherein said second conductor and said fifth conductor are substantially coplanar with said third conductor and said fourth conductor.
29. The probing device of claim 26 wherein said first interconnecting conductor is substantially coplanar with said second conductor.
30. The probing device of claim 26 wherein said second conductor provides a force signal.
31. The probing device of claim 30 wherein said fifth conductor provides a sense signal.
32. The probing device of claim 30 wherein said third conductor provides a guard signal.
33. The probing device of claim 27 wherein said second interconnecting conductor is substantially coplanar with said second one and said first one.
34. The probing device of claim 27 wherein said second interconnecting conductor is substantially coplanar with said third one.

35. The probing device of claim 27 wherein said first one provides a force signal.
36. The probing device of claim 35 wherein said second one provides a sense signal.
37. The probing device of claim 35 wherein said fourth one provides a guard signal.

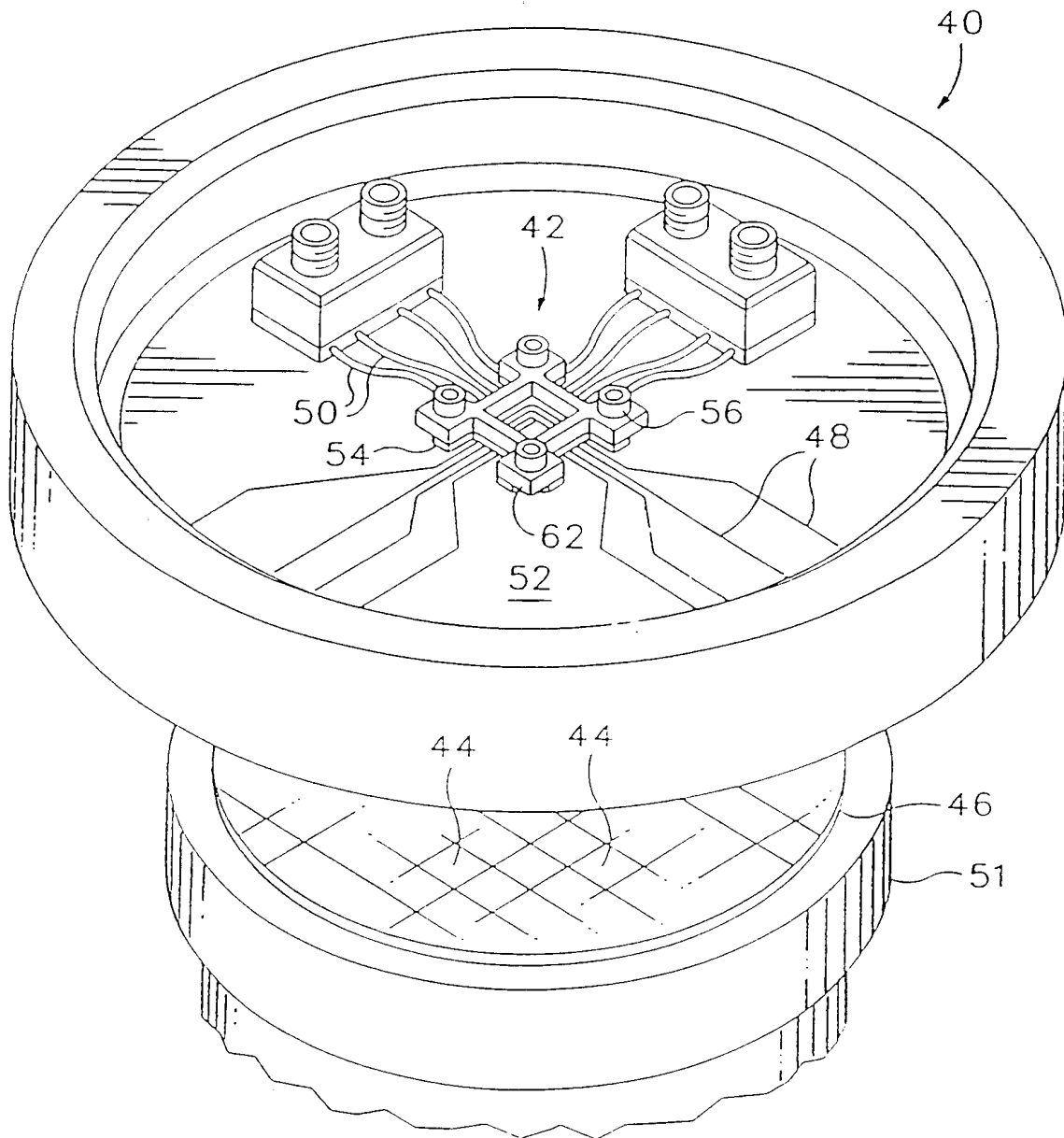
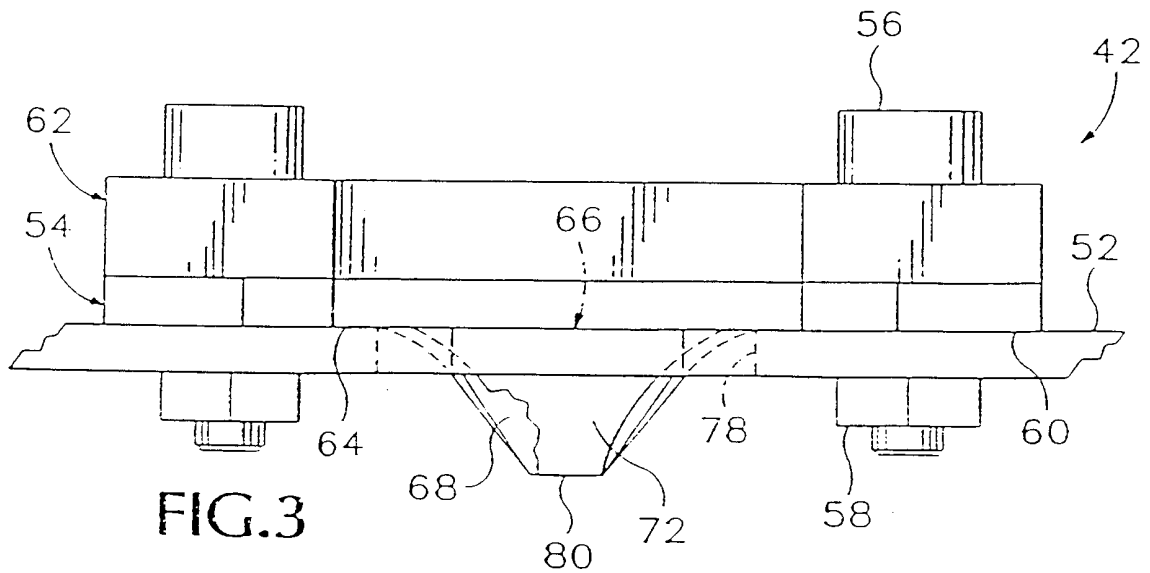
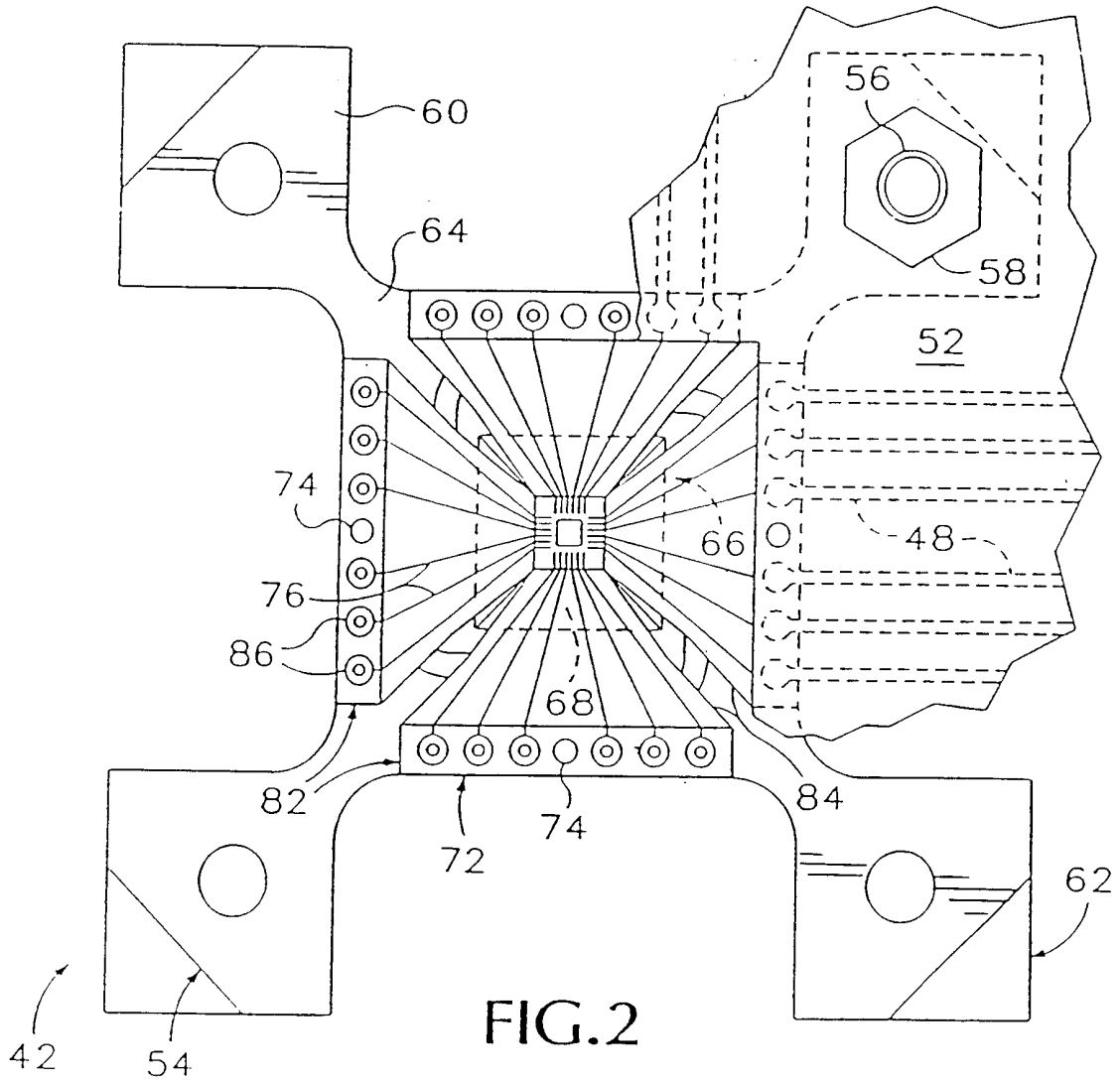
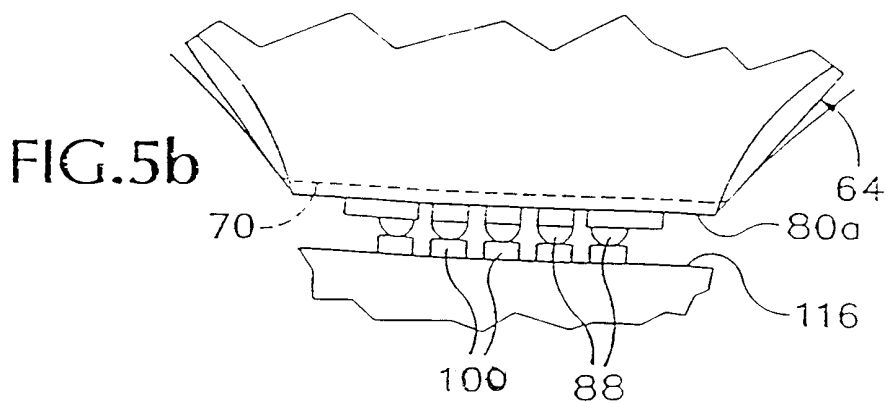
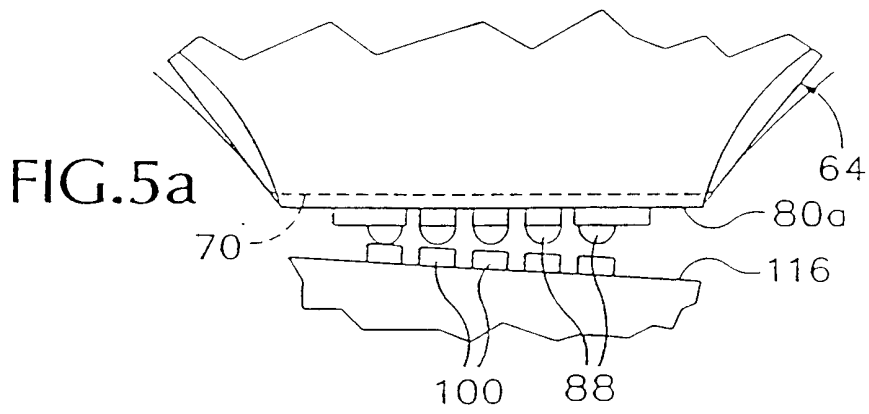
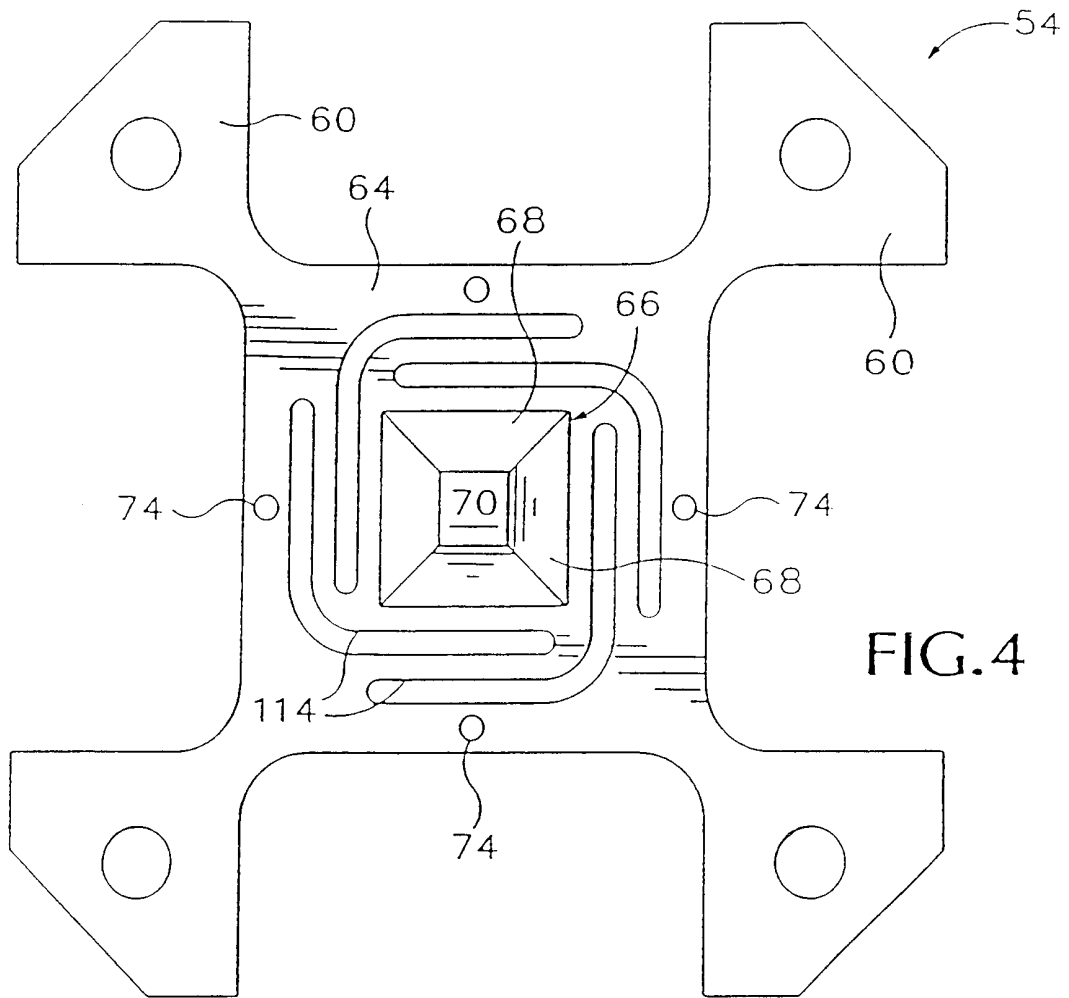

FIG.1







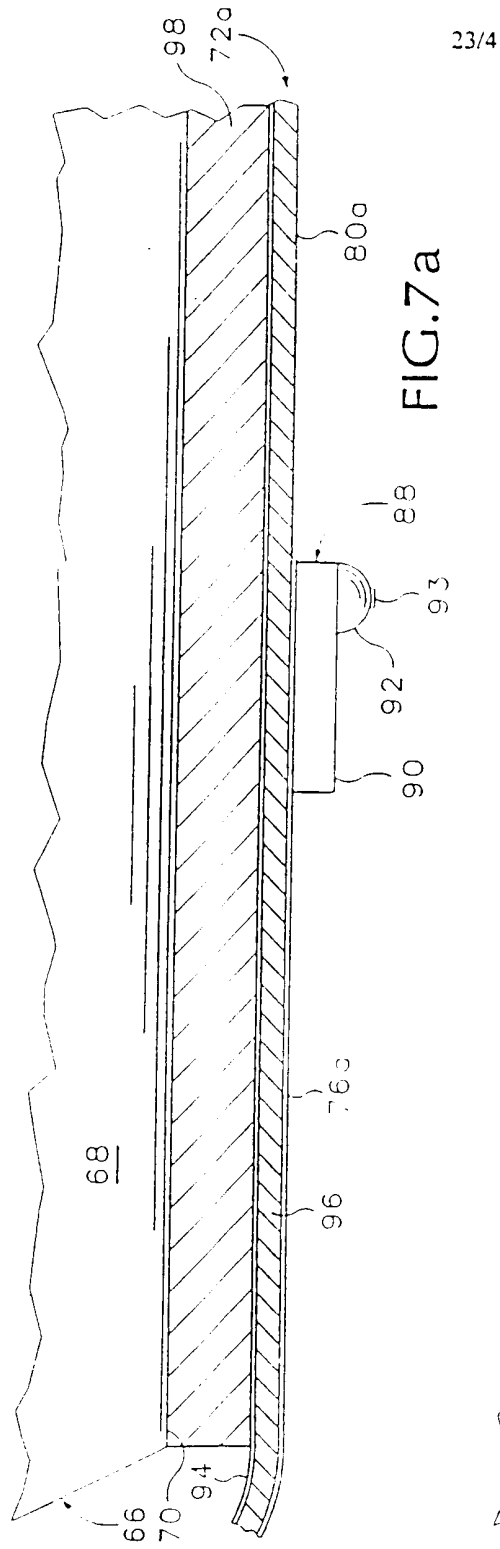

FIG. 7a

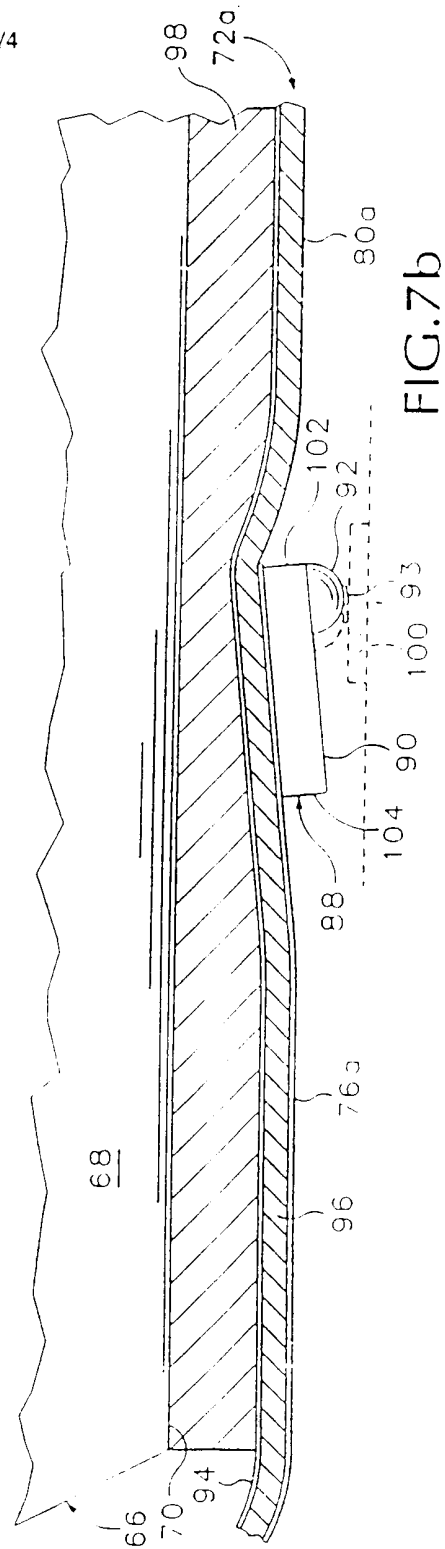
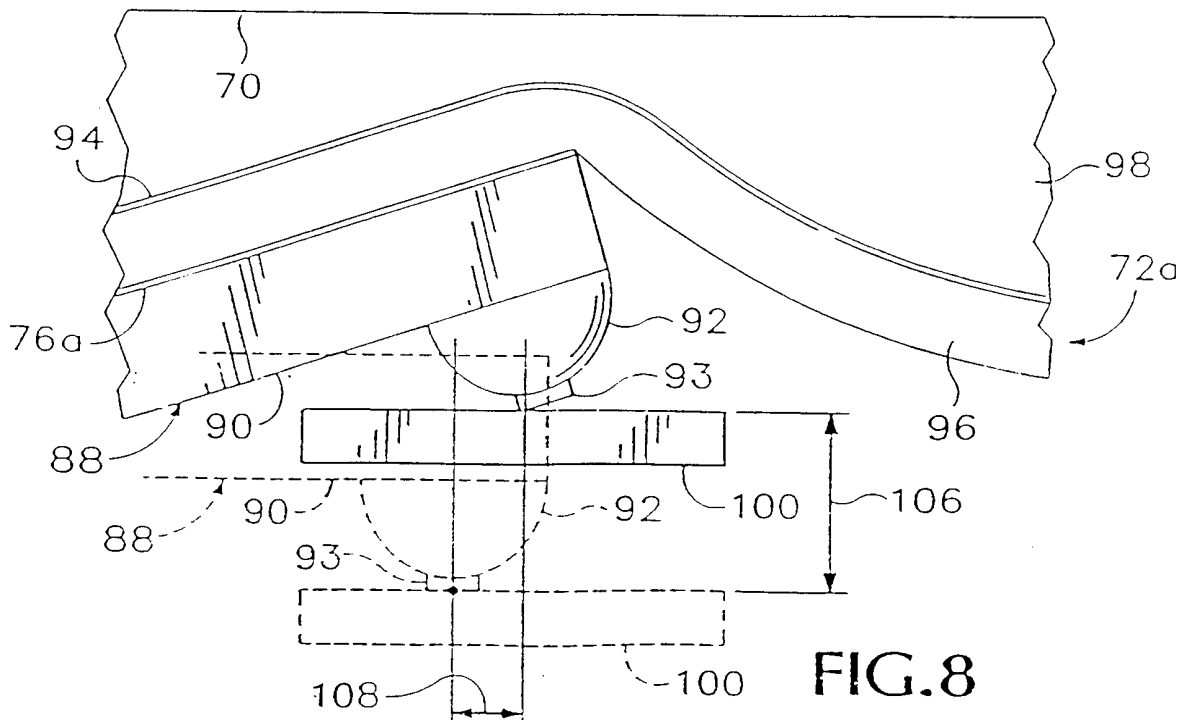
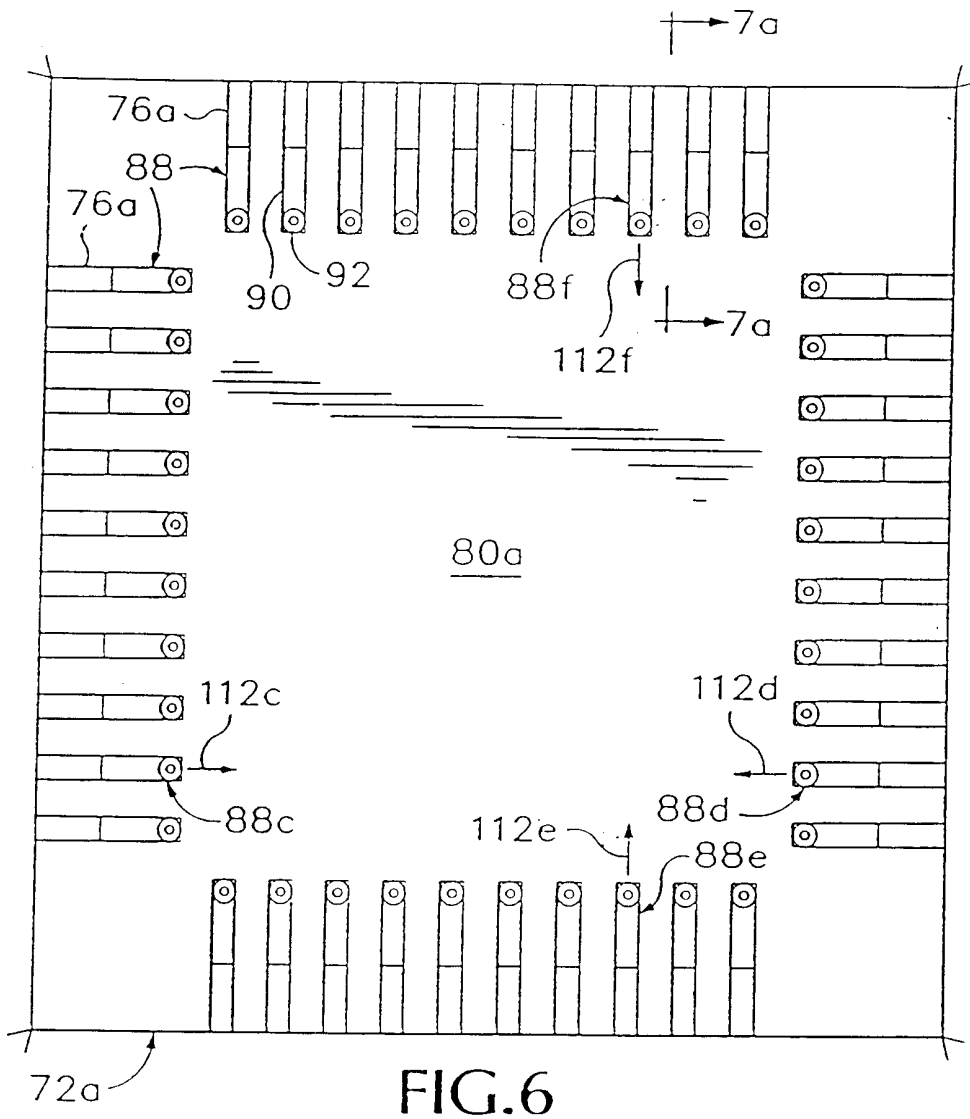

FIG. 7b



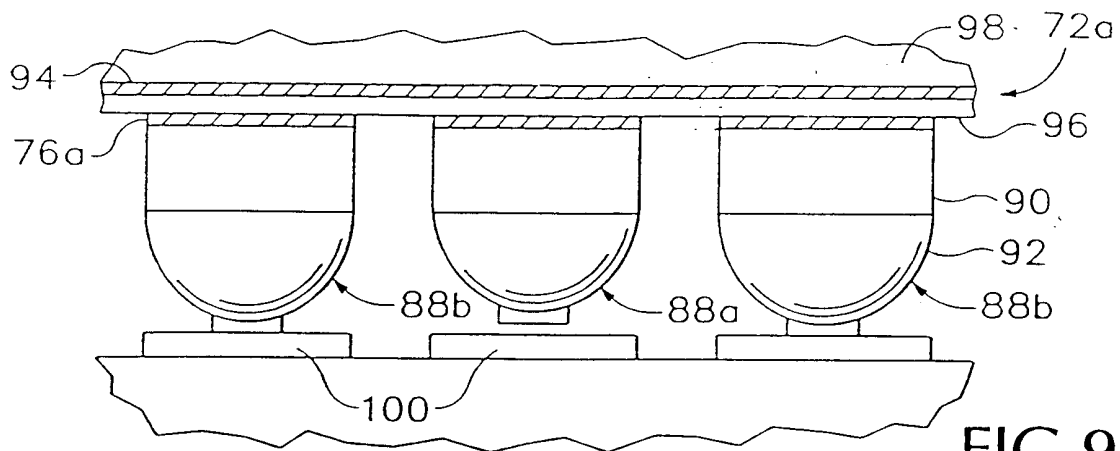

FIG. 9a

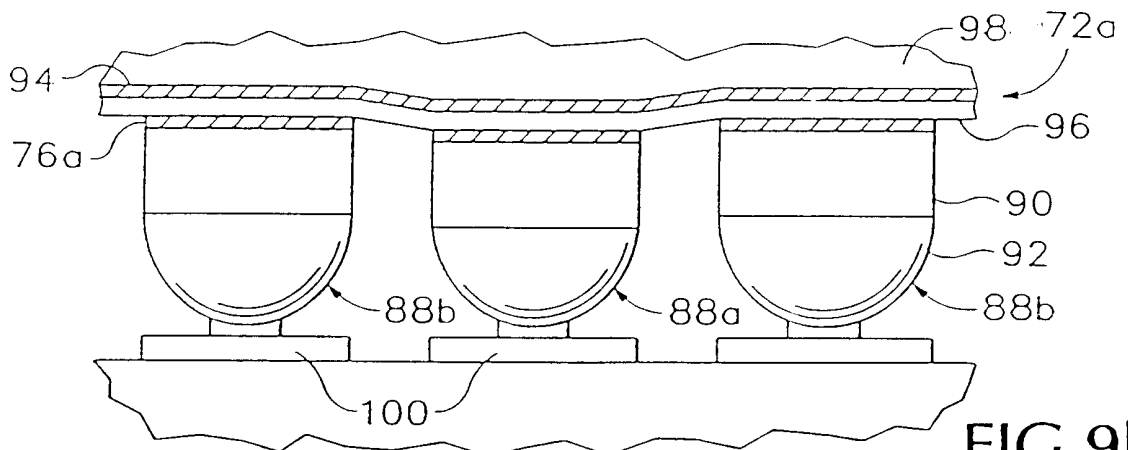

FIG. 9b

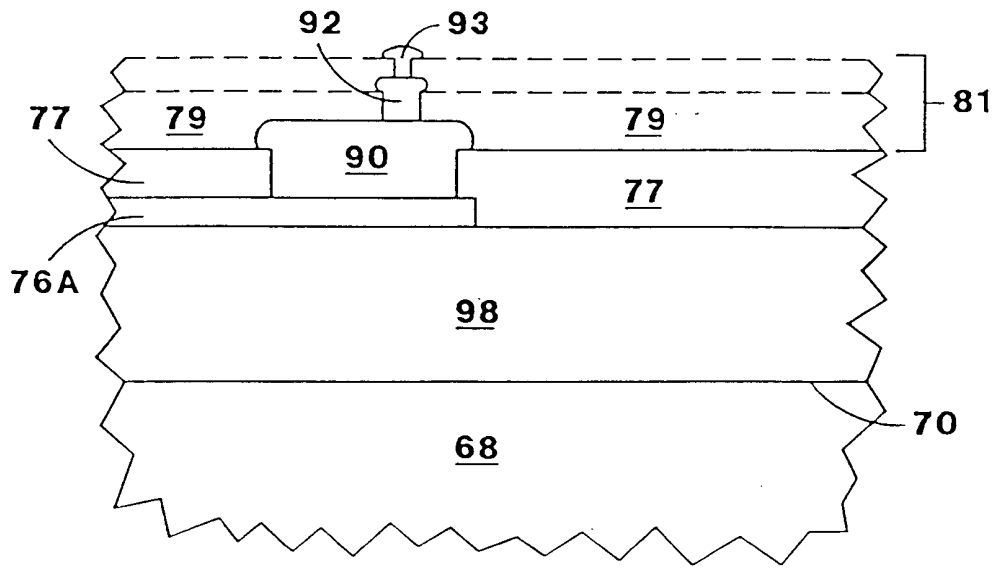

FIG. 10

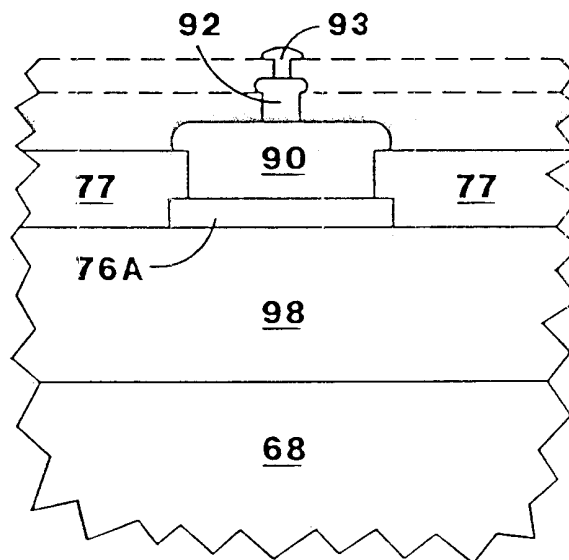

FIG. 11

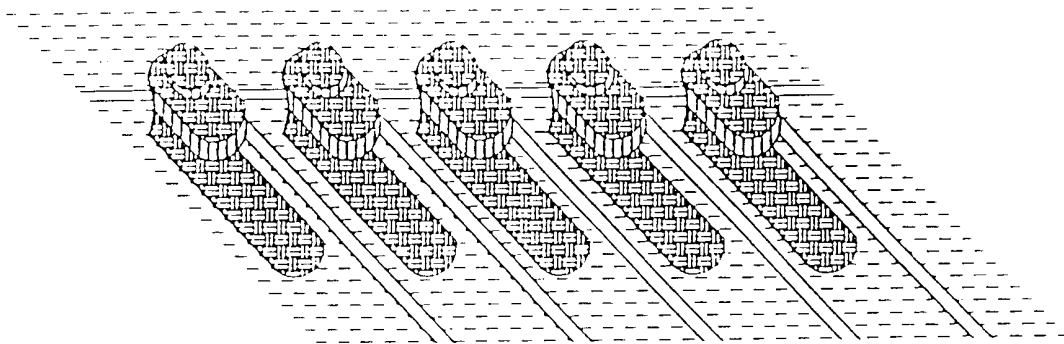

FIG. 12

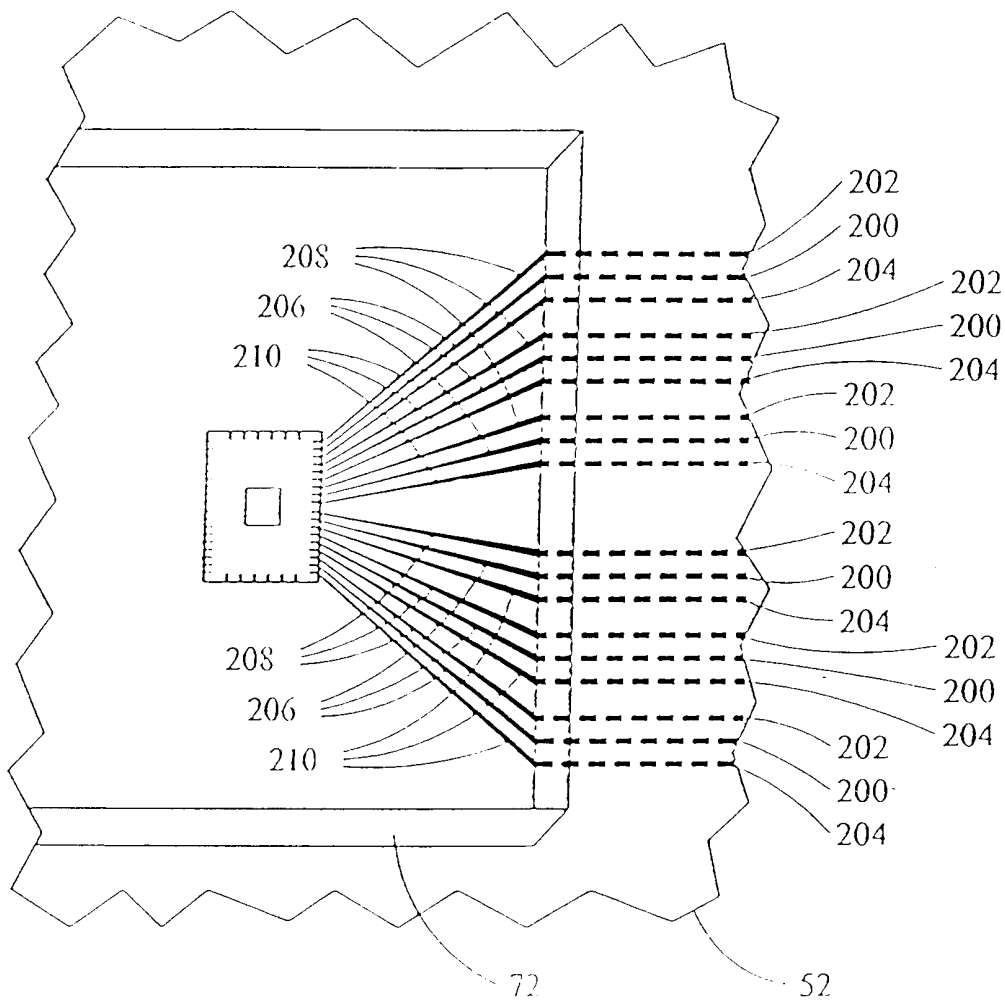

FIG. 13

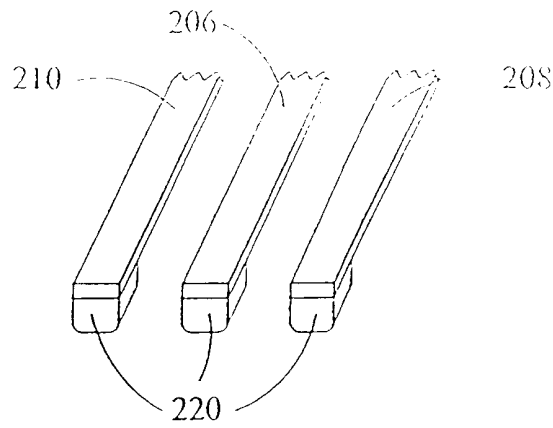

FIG. 14A

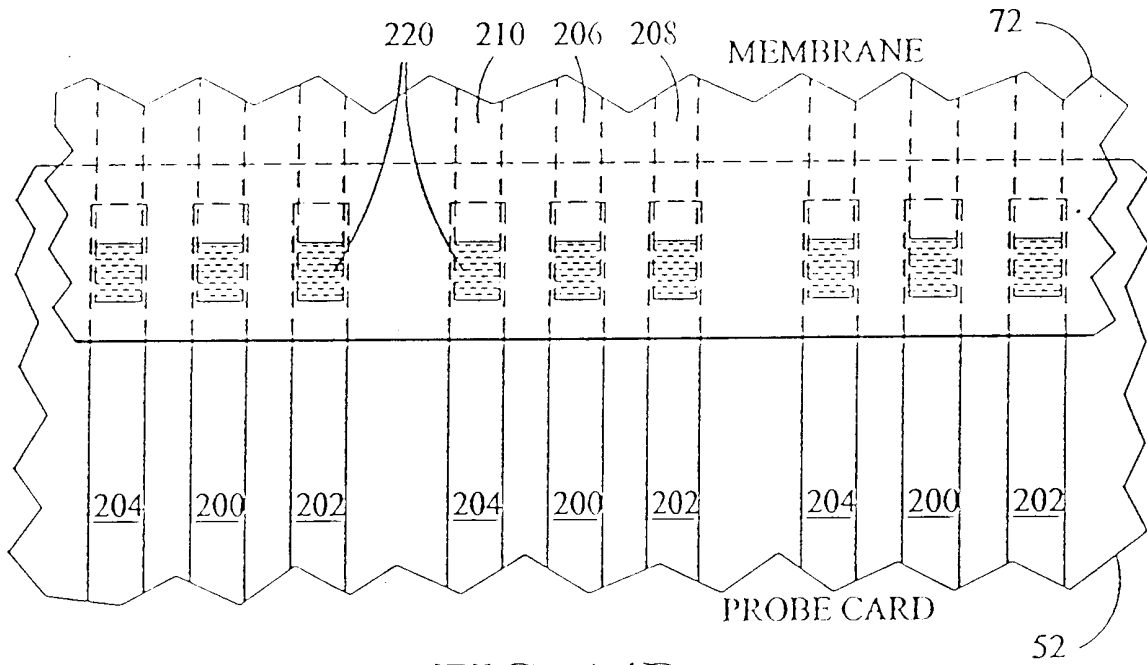

FIG. 14B

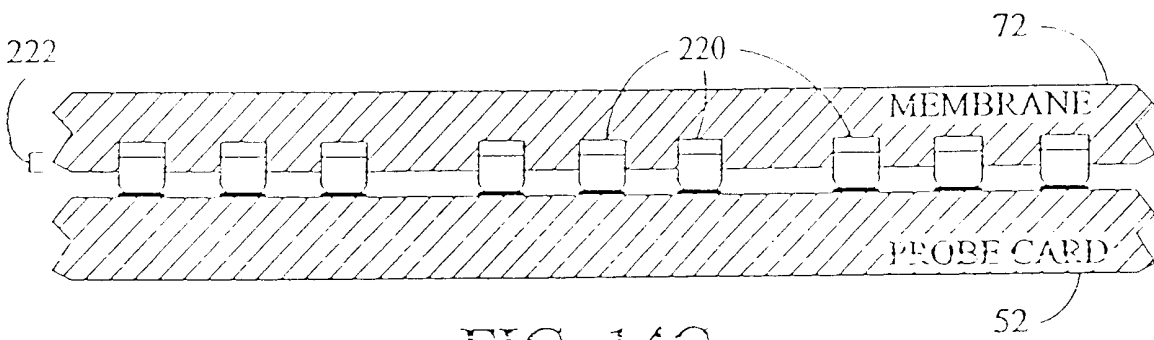

FIG. 14C

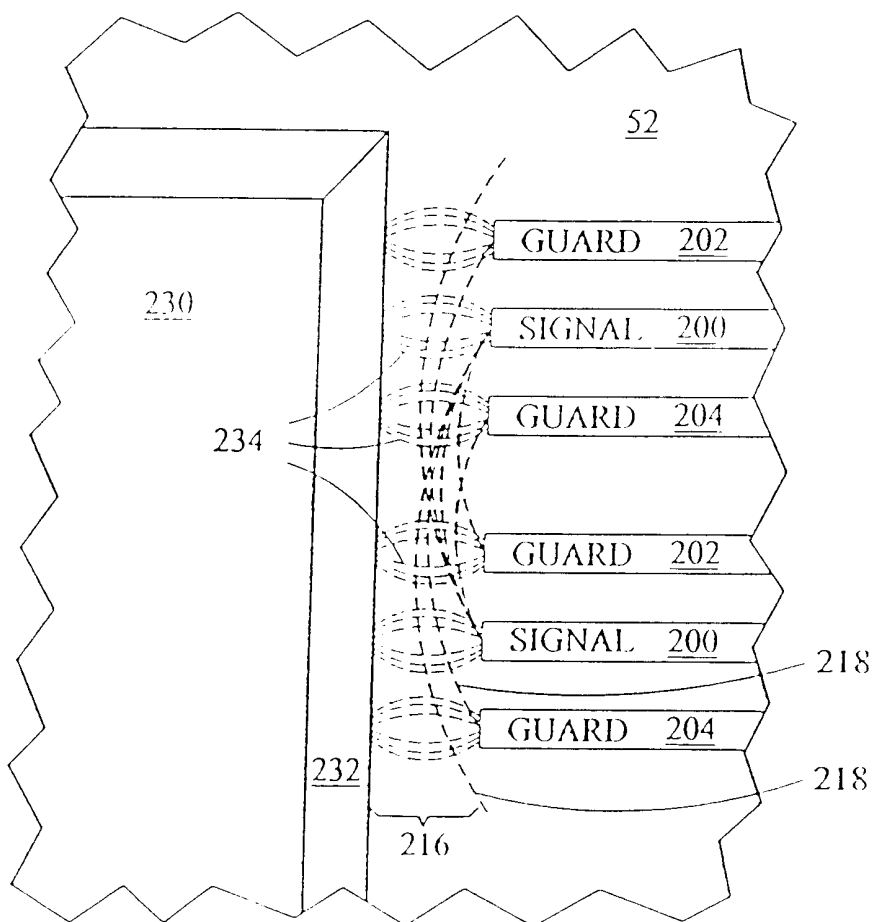

FIG. 15



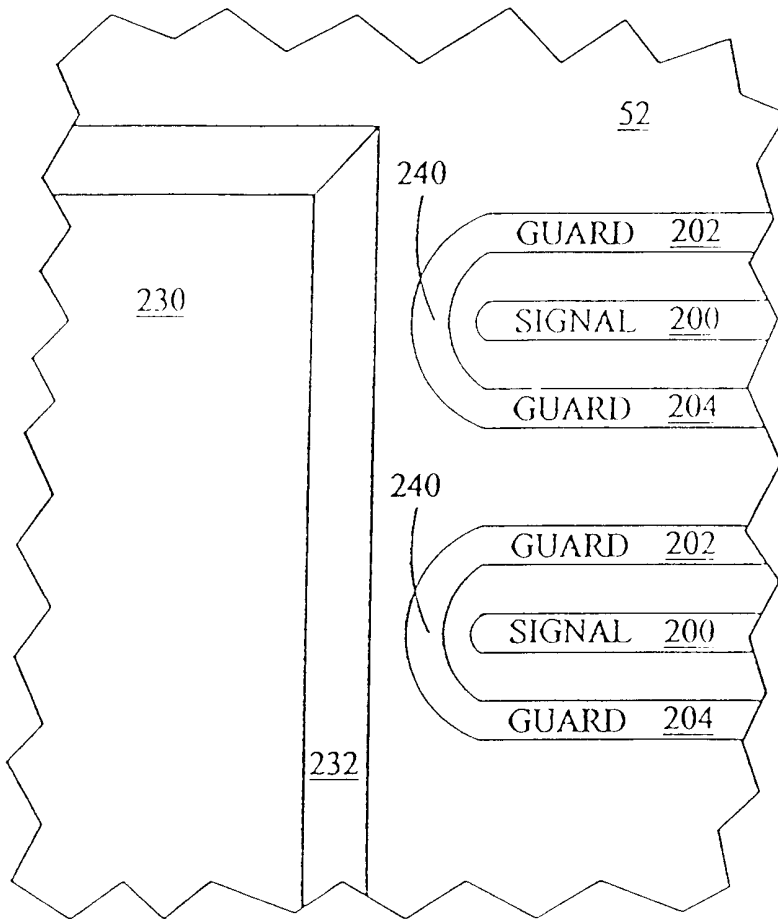

FIG. 16

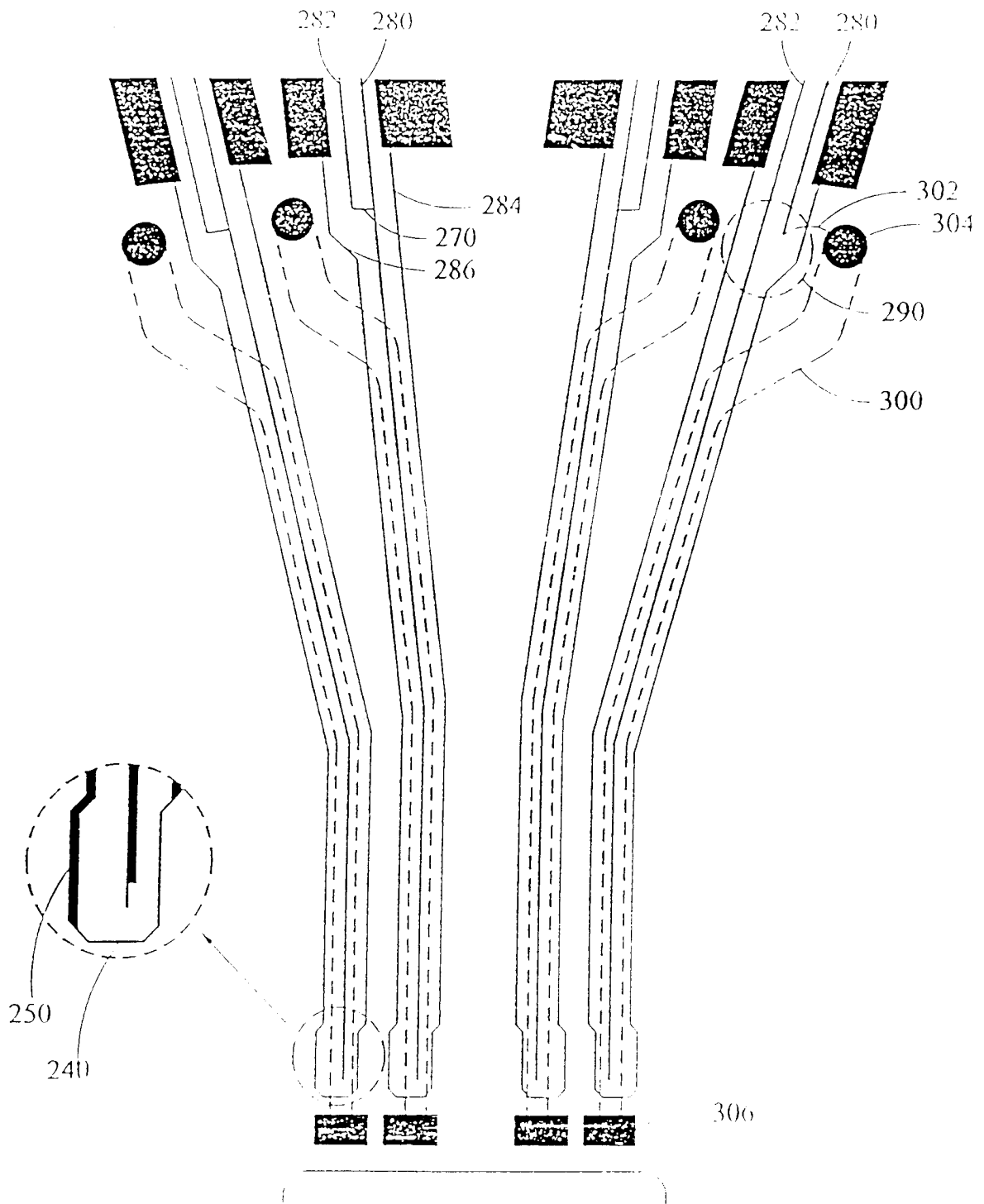
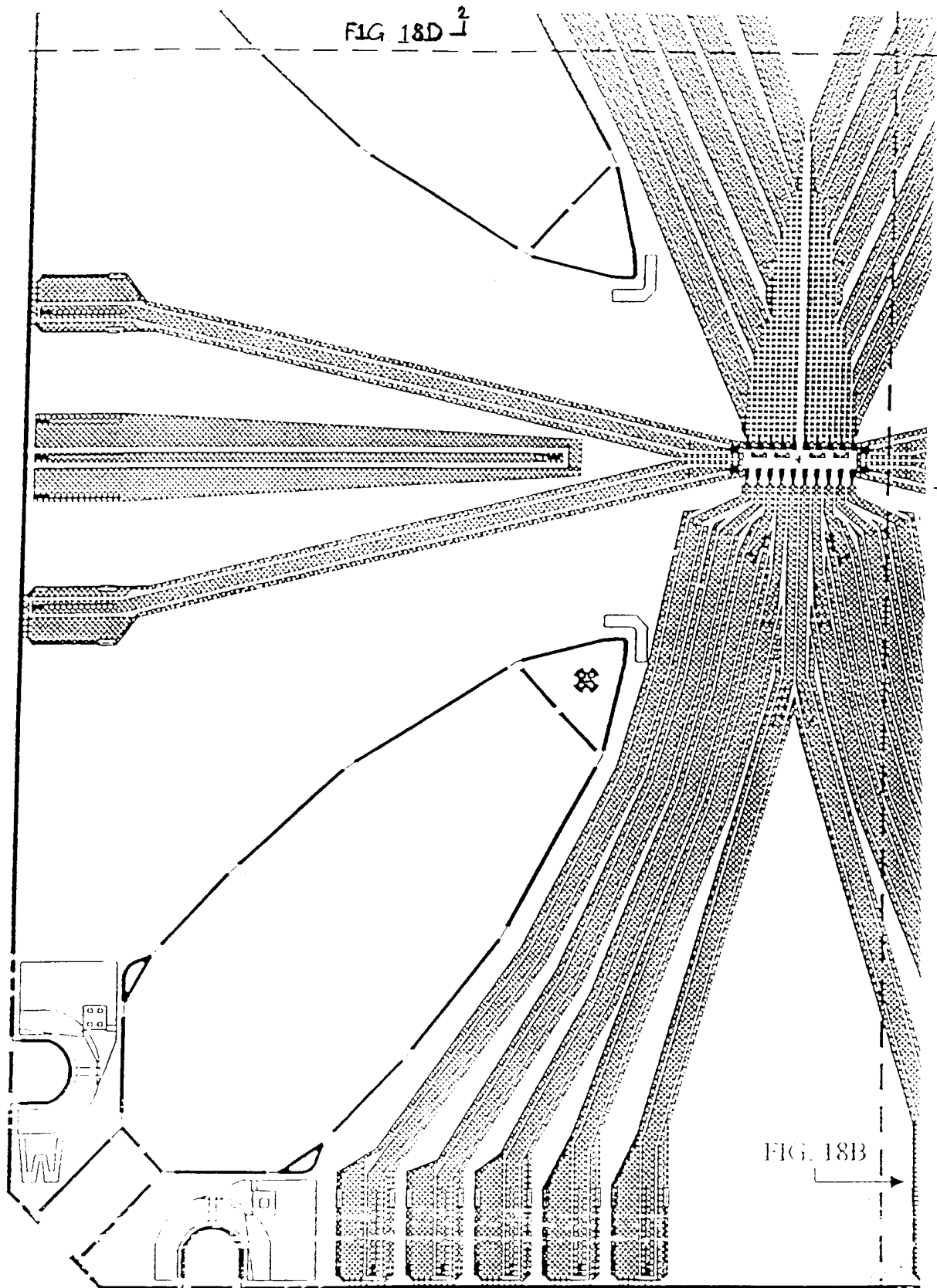

FIG. 17



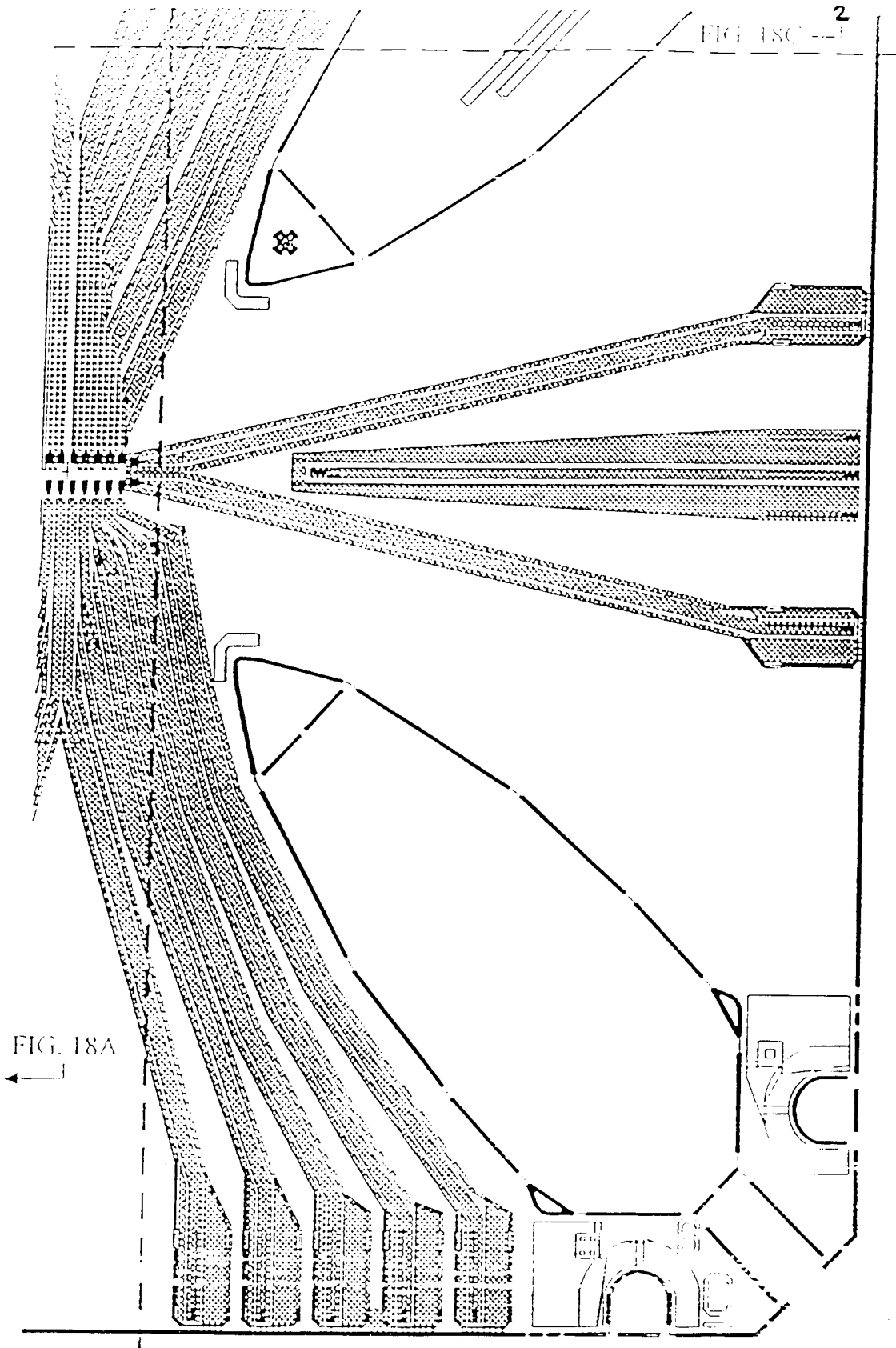

FIG. 18A

FIG. 18B

FIG. 18C

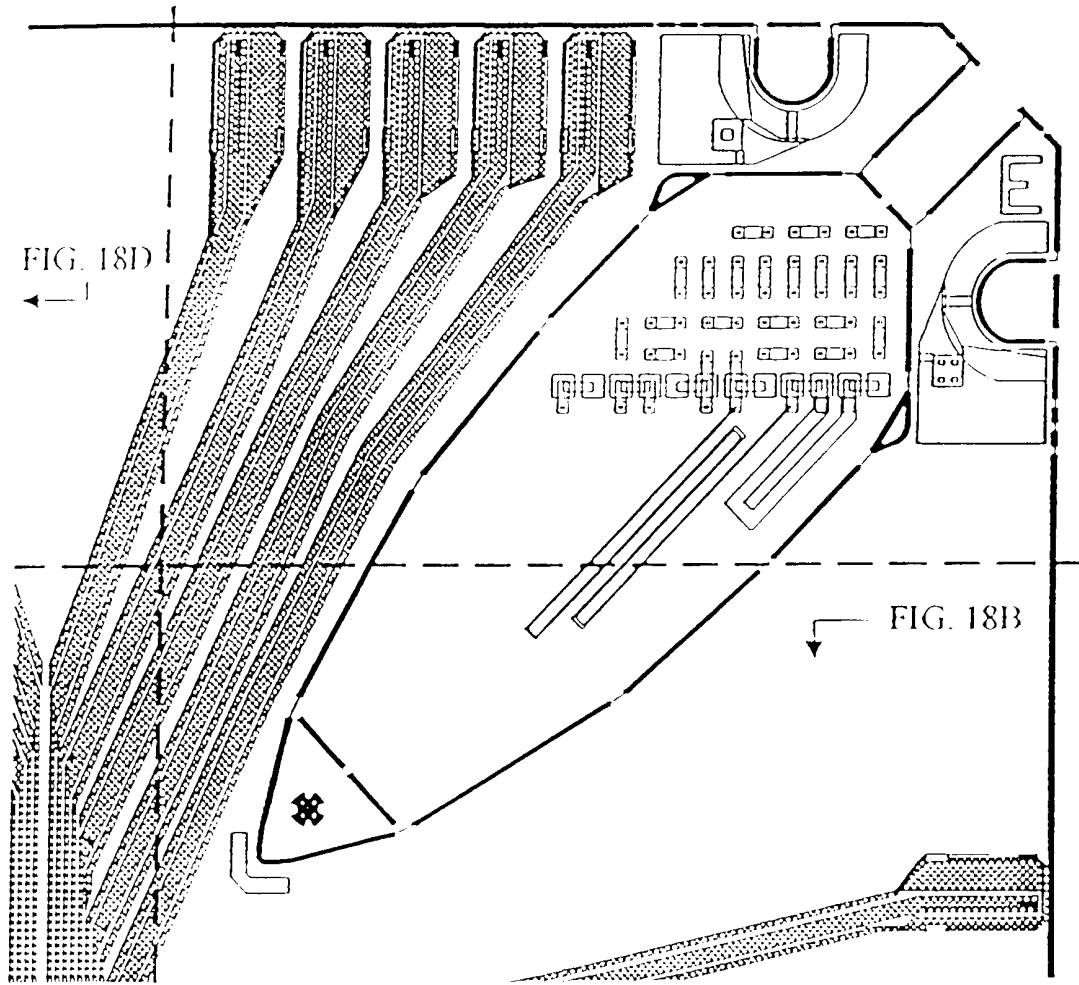

FIG. 18C

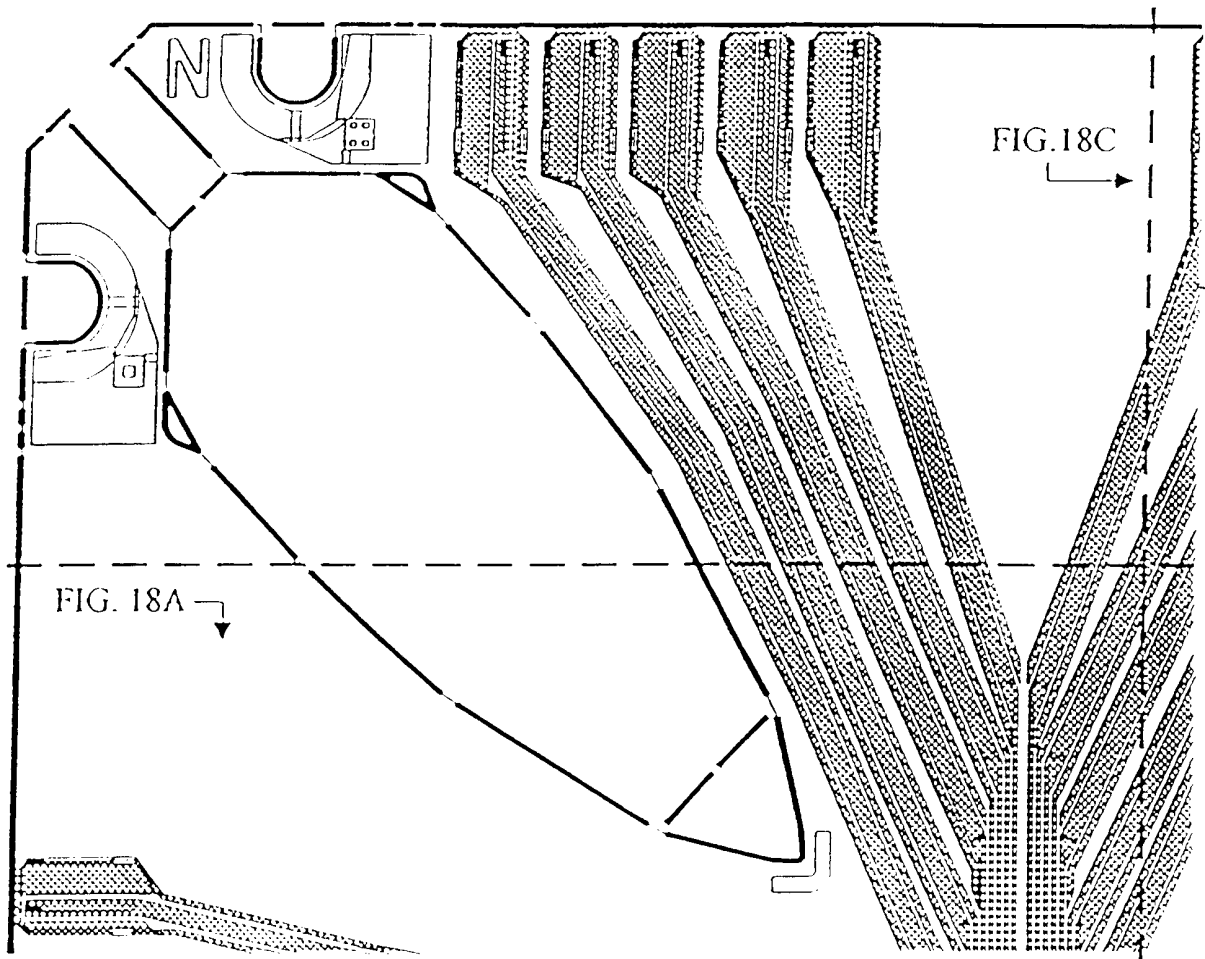

FIG. 18D

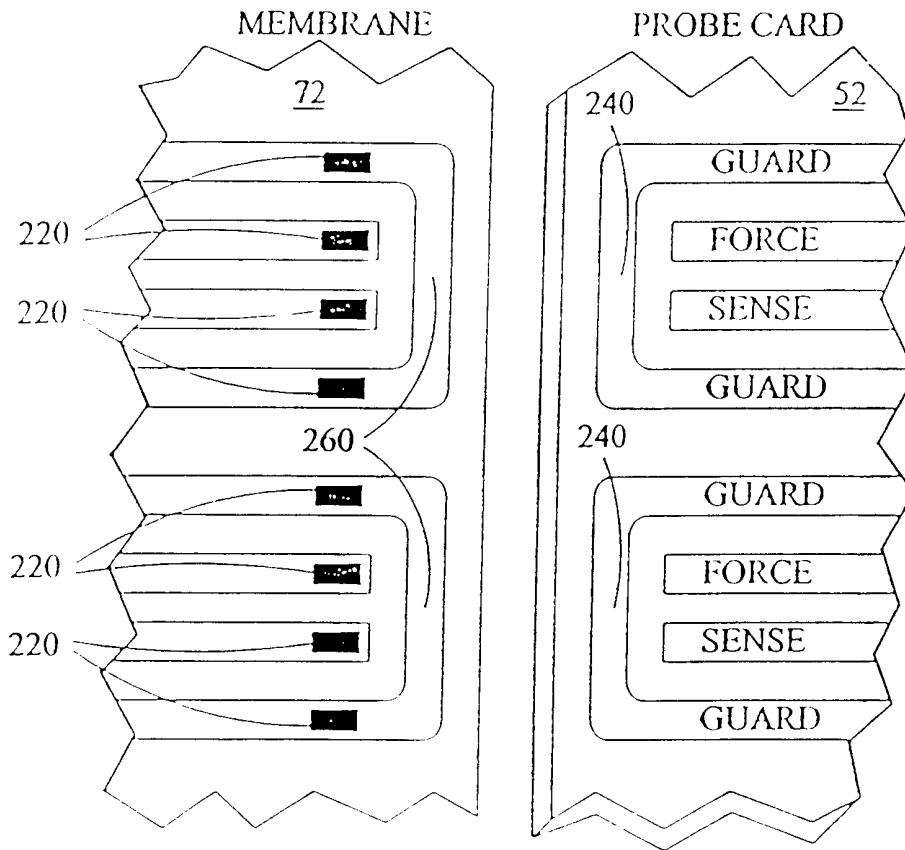

FIG. 19

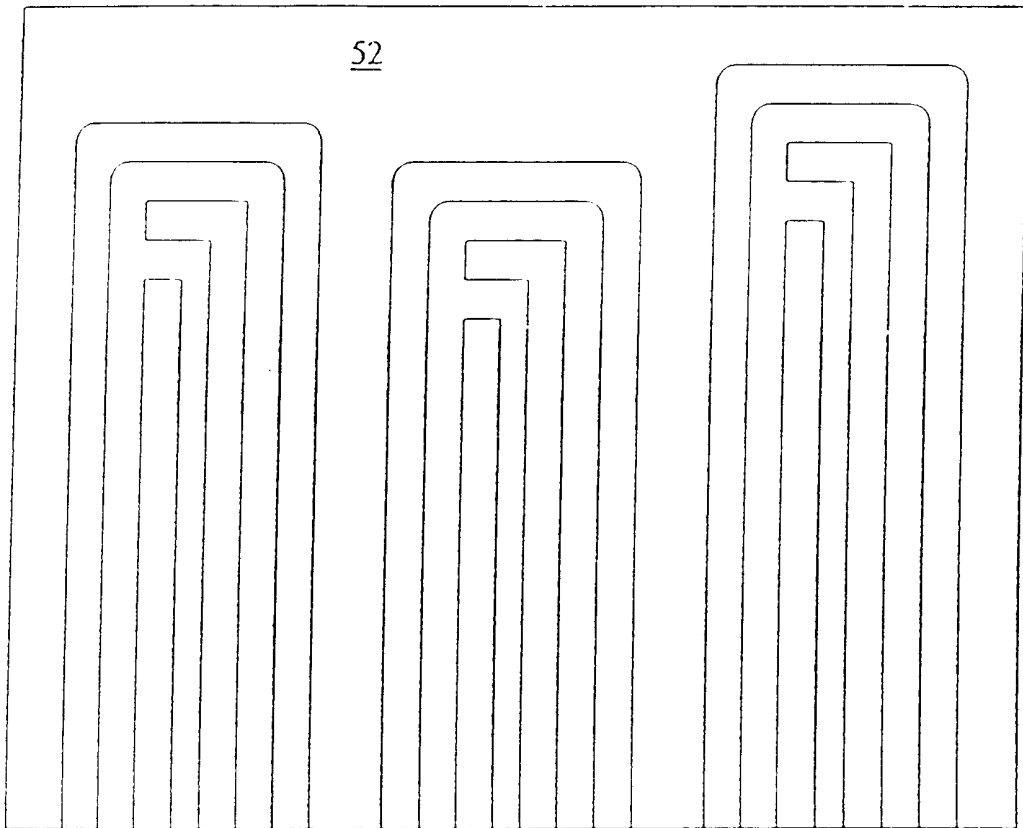

FIG. 20



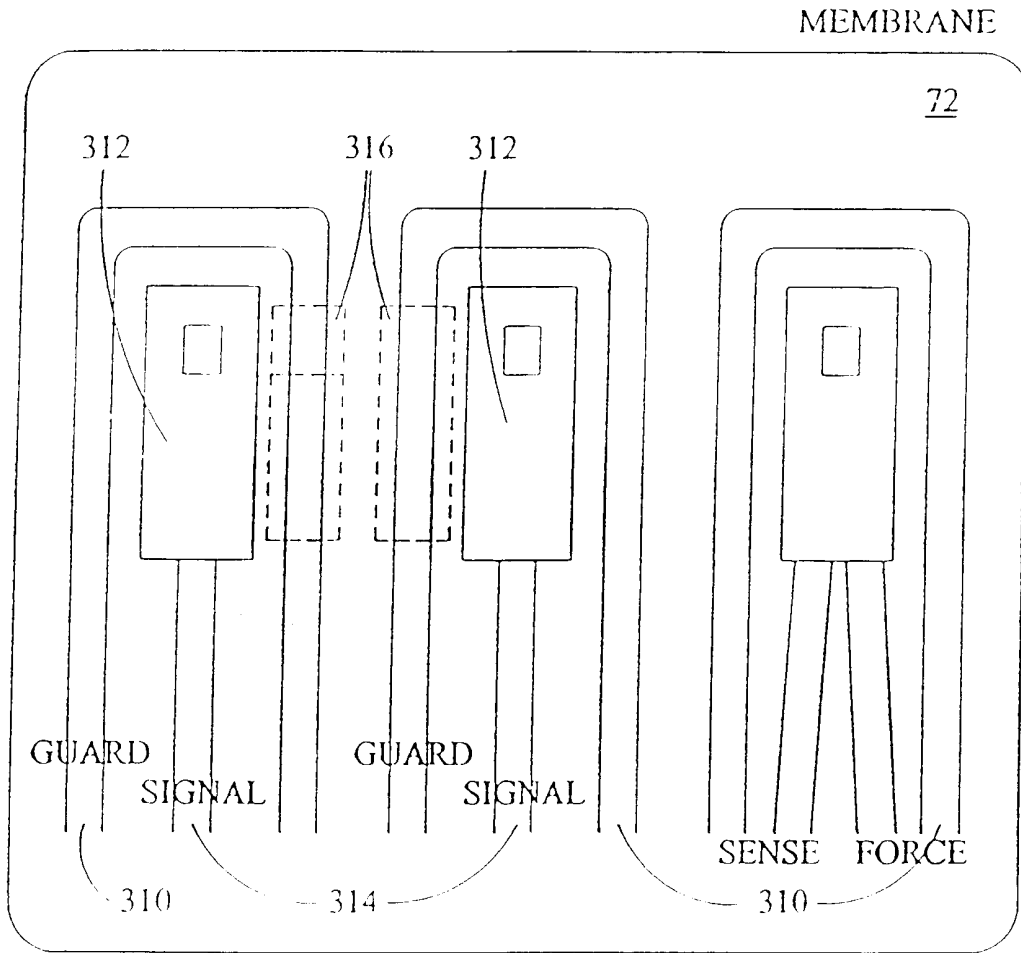

FIG. 21

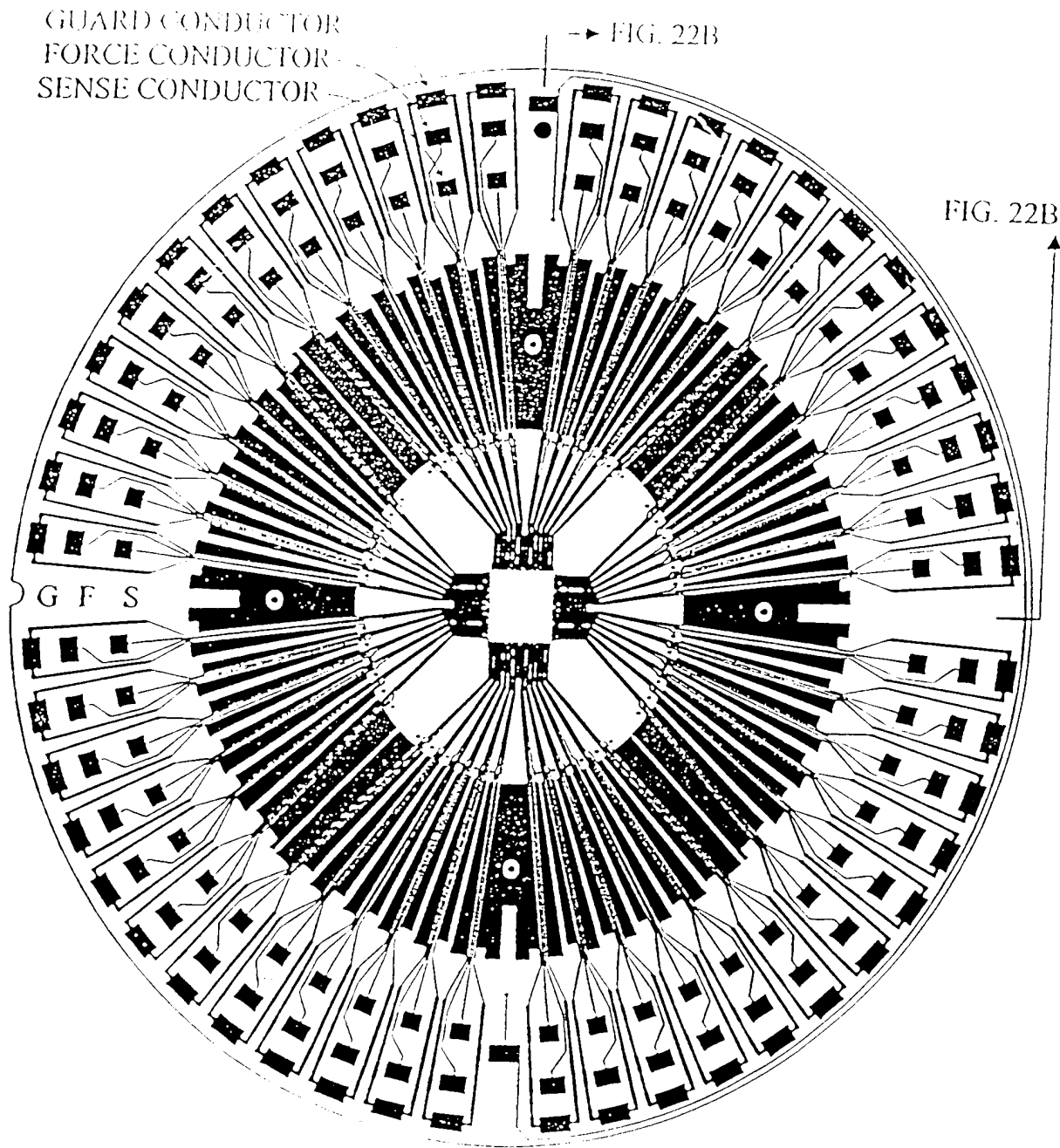

FIG. 22A

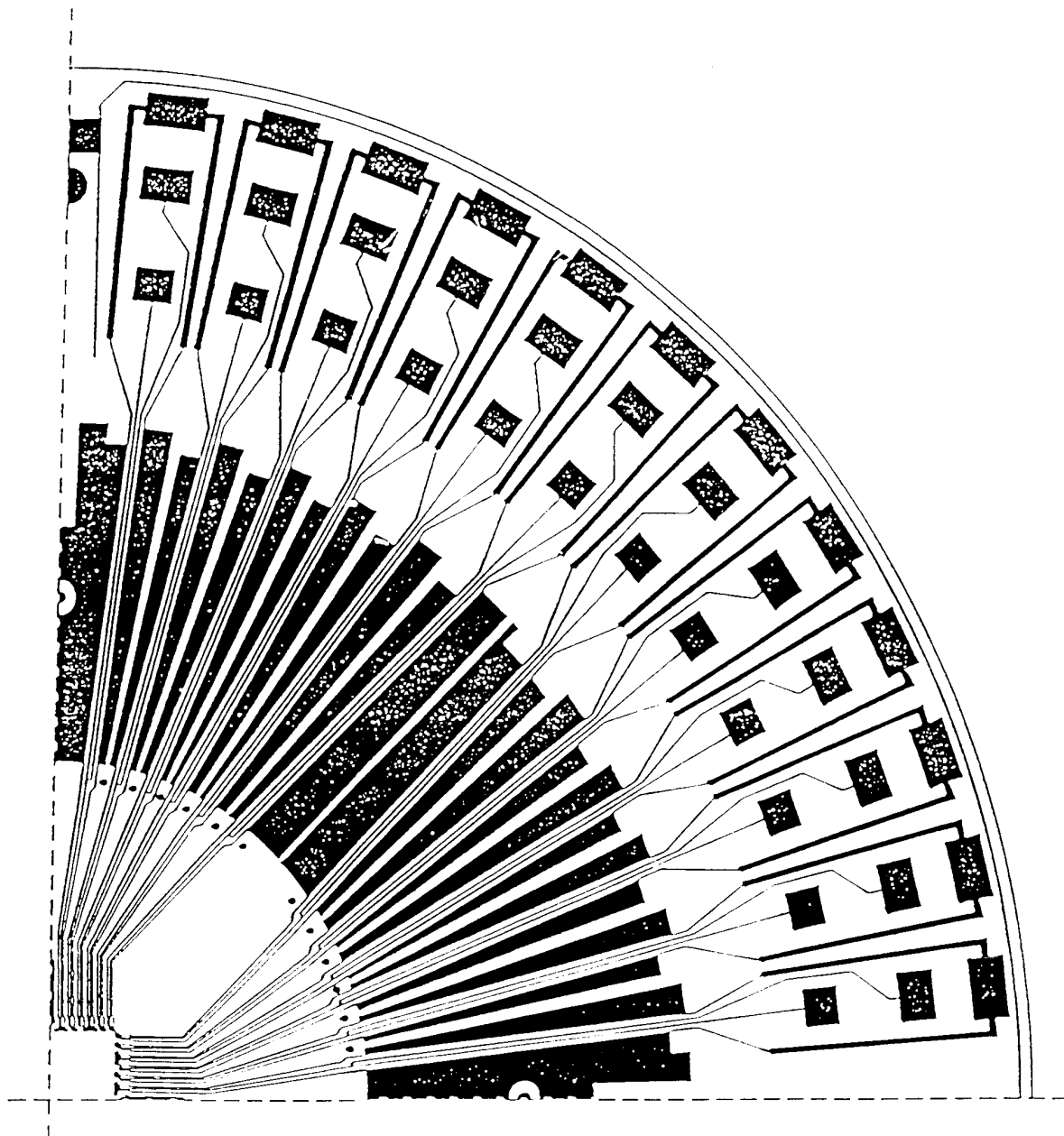

FIG. 22B

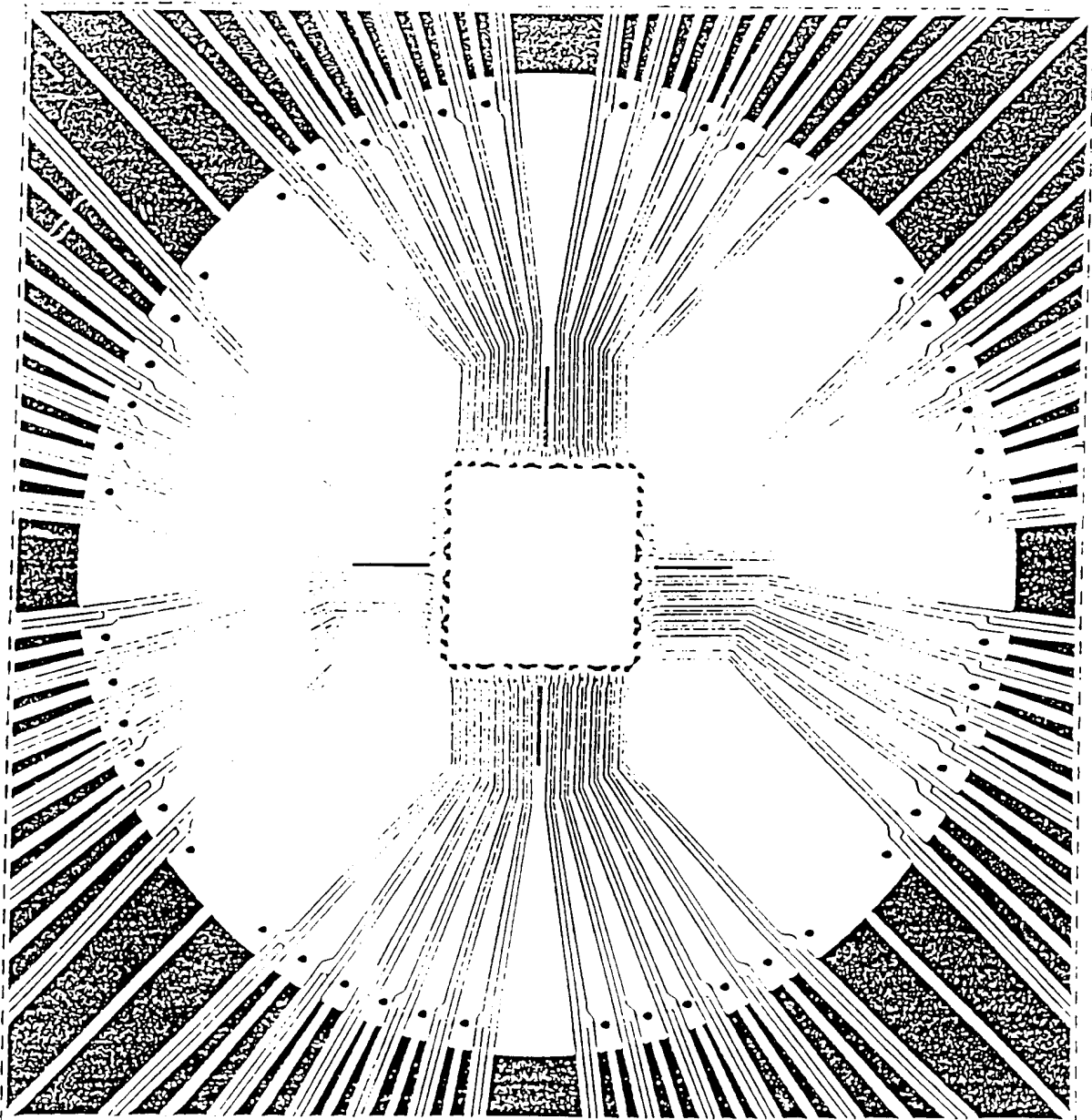

FIG. 22C

# INTERNATIONAL SEARCH REPORT

International application No.

PCT/US01/05430

**A. CLASSIFICATION OF SUBJECT MATTER**  
 IPC(7) : G01R 31/02  
 US CL : 324/754  
 According to International Patent Classification (IPC) or to both national classification and IPC

**B. FIELDS SEARCHED**  
 Minimum documentation searched (classification system followed by classification symbols)  
 U.S. : 324/755, 761, 763, 765;

Documentation searched other than minimum documentation to the extent that such documents are included in the fields searched

Electronic data base consulted during the international search (name of data base and, where practicable, search terms used)

**C. DOCUMENTS CONSIDERED TO BE RELEVANT**

Category *	Citation of document, with indication, where appropriate, of the relevant passages	Relevant to claim No.
A	US 5,589,781 A (HIGGINS et al) 31 December 1996 (31.12.1996), entire document.	1
A	US 5,914,613 A (GLEASON et al) 22 June 1999 (22.06.1990), entire document.	1

Further documents are listed in the continuation of Box C.  See patent family annex.

* Special categories of cited documents:	"T"
"A" document defining the general state of the art which is not considered to be of particular relevance	later document published after the international filing date or priority date and not in conflict with the application but cited to understand the principle or theory underlying the invention
"E" earlier application or patent published on or after the international filing date	"X" document of particular relevance; the claimed invention cannot be considered novel or cannot be considered to involve an inventive step when the document is taken alone
"L" document which may throw doubts on priority claim(s) or which is cited to establish the publication date of another citation or other special reason (as specified)	"Y" document of particular relevance; the claimed invention cannot be considered to involve an inventive step when the document is combined with one or more other such documents, such combination being obvious to a person skilled in the art
"O" document referring to an oral disclosure, use, exhibition or other means	"&" document member of the same patent family
"P" document published prior to the international filing date but later than the priority date claimed	

Date of the actual completion of the international search: \_\_\_\_\_ Date of mailing of the international search report: **24 APR 2001**

Name and mailing address of the ISA/US: Commissioner of Patents and Trademarks, Box PCT, Washington, D.C. 20231, Facsimile No. (703)305-3230  
 Authorized officer: SAFET METJAHIC (with signature), Telephone No. (703) 305-4900 (with signature)