

Nov. 25, 1952

P. MUELLER

2,619,082

FORCED AIR FLOW AIR HEATING FURNACE

Filed May 13, 1950

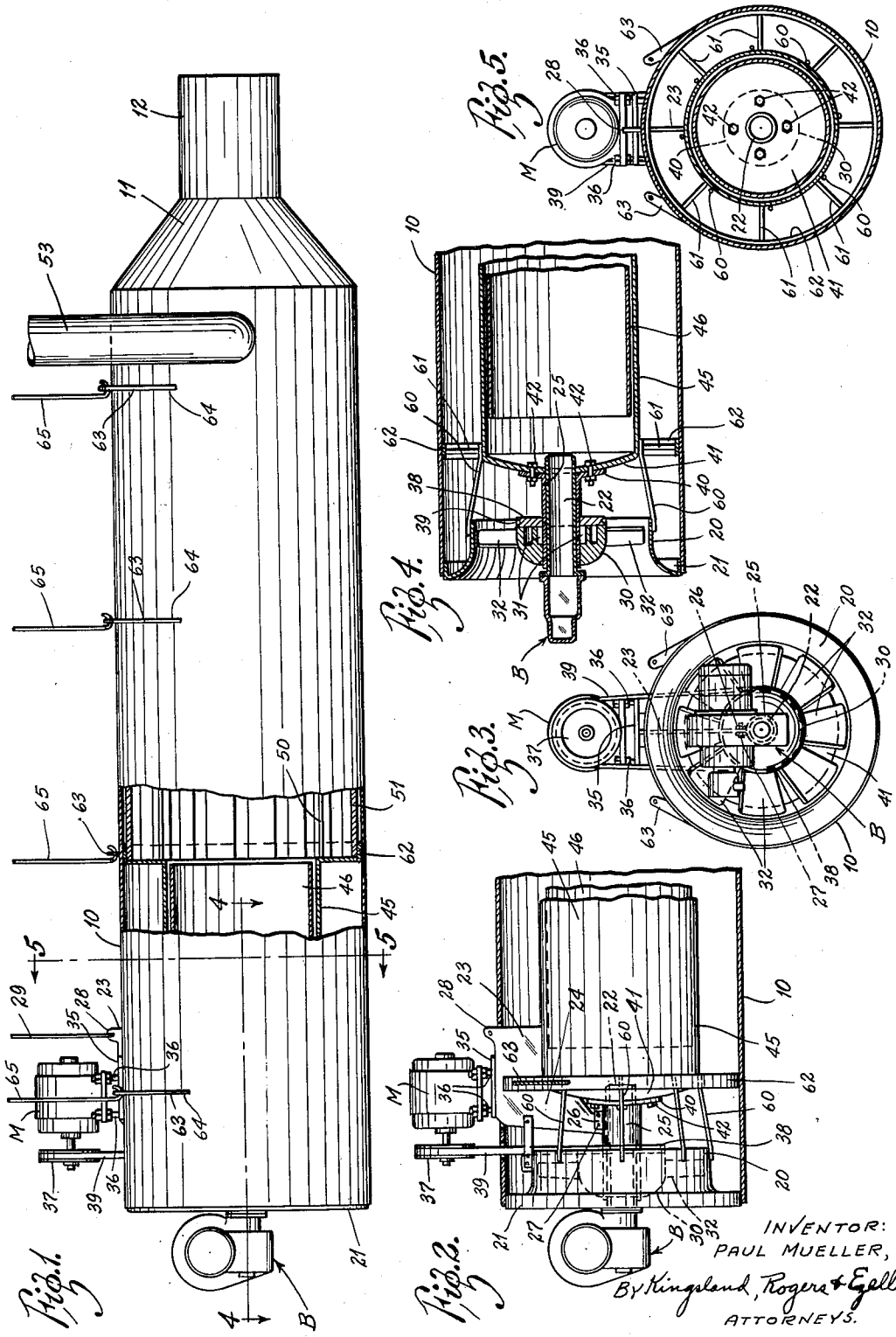

INVENTOR:
PAUL MUELLER,
By Kingland, Rogers & Egan
ATTORNEYS.

UNITED STATES PATENT OFFICE

2,619,082

FORCED AIR FLOW AIR HEATING FURNACE

Paul Mueller, Springfield, Mo., assignor to Paul Mueller Company, Springfield, Mo., a corporation of Missouri

Application May 13, 1950, Serial No. 161,757

11 Claims. (Cl. 126—110)

1

This invention relates to space heaters and more particularly to that type of unit heaters which may be mounted in a suspended position in such enclosed spaces as factories, warehouses, garages or the like.

An object of the invention is to provide a unit type heater which may be fired by gas or oil and so arranged as to be compact in design, economically manufactured and efficient in heat transfer so that it may be operated with a relatively low fuel consumption, for a relatively high heat output.

Another object of the invention is to provide a heater of the type mentioned in which the burner element discharges through the hub or axially of an axial flow fan arranged to move the air stream lineally along the outer wall of the combustion chamber, and through the heat exchanger, which is formed as an extension of the combustion chamber. There is thus provided a heating apparatus which has a high heating efficiency, and in which there is substantial uniformity and distribution of the heated gas throughout the length of the unit.

More particularly, the invention provides a heater which includes at one end a burner fired by gas or oil, the nozzle of which discharges into a combustion chamber in axial alignment with the burner nozzle, and with the axis of a fan blower which impels the air stream. The heat exchanger of the apparatus is arranged in linear extension of the combustion chamber and is encased within a spaced wall forming the annular air chamber so arranged as to cause the air stream to be impelled through the apparatus in heat exchange relationship with the outer wall of the combustion chamber and of the gas conduit section of the heat exchanger. Thus there is provided means for impelling the air stream in an out-of-contact relationship forwardly through the entire length of the heater. The air chamber discharges into the space to be heated, so that advantage in heating efficiency is taken of the heat transfer by convection heating through the discharge of the heated air from the forward end of the heater.

Further detailed advantages of the construction will be apparent from the following description taken in connection with the accompanying drawing, in which:

Fig. 1 is a side elevation of the apparatus with parts broken away in order to illustrate certain details of the structure of the apparatus;

Fig. 2 is a vertical section through the rear portion of the apparatus for better illustration of the burner, the blower element and a part of the combustion chamber;

Fig. 3 is a rear end elevation of the apparatus;

Fig. 4 is a horizontal section taken substantially on the line 4—4 of Fig. 1; and

Fig. 5 is a cross section taken substantially on the line 5—5 of Fig. 1.

In the embodiment of the invention illustrated

2

in the drawing the elements of the apparatus are encased in an outer shell 10 of cylindrical form. At the forward end of the casing 10 there is a cone-shaped extension 11 constituting a header 5 into which may be connected a heated air discharge nozzle 12 or a plurality of nozzles (not shown) may be connected into the header if desired for additional direct discharge and distribution of the heated air stream into the space to be heated.

The elongated cylindrical form of the apparatus adapts it to be suspended in the space to be heated although it will be understood that it may be otherwise mounted.

In order to provide, however, for the suspension of the apparatus from the ceilings of the building space in which it may be used, a suspension means for the unit will be later described.

The outer flange 21 of the fan inlet ring 20 is fitted into the rearward end of the shell 10. The form of the fan inlet ring 20 and its location provide a funnel-shaped intake for air to be impelled through the heated air conduit, which surrounds the combustion chamber and the inner or gas section of the heat exchanger.

The burner element of the apparatus is located externally of the rear end of the casing 10. The burner may be of any desired type, and the housing of the element is indicated on the drawing by the letter B.

The burner is mounted in such a manner that the nozzle extends coaxially of the casing 10, so that it discharges directly into the center of the chamber constituting the combustion chamber.

The support for the burner is a bracket which comprises a more or less L-shaped plate having an upper horizontal section 23 and a vertically disposed section 24, the lower end of which section 24 connects with a sleeve 25, which has spaced ears 26 formed thereon. The lower edge of the bracket section 24 is positioned between the ears and is removably connected therewith by bolts 27, which pass through the ears and through an opening in the lower margin of the plate section 24. The upper edge of the horizontal section 23 of the bracket may have an ear 28 formed thereon in order to provide for a connection with a suspension rod indicated at 29.

The burner nozzle 22 is mounted through the sleeve 25 and is thereby supported.

The sleeve 25 also constitutes a bearing member for a fan. The fan structure includes a hub member 30, which is mounted on the sleeve 25 by an anti-friction bearing 31. A series of radial blades 32 are carried by the hub, and so arranged as to impel the air stream forwardly in a lineal direction.

The fan is driven by a motor M which is supported on a mounting plate 35 carried by the upper wall of the bracket 23—24. The base of the motor is adjustable, providing for belt tensioning by bolts 36.

The motor shaft has mounted thereon a pulley 37. The hub 30 of the fan has connected thereto a pulley 38. A belt connection 39 between said pulleys, and which extends through a slot in the outer shell 10, serves as a power drive for said fan.

The inner end of the sleeve 25 is formed to provide an annular flange 40 which is bolted to a head plate 41 of the outer casing of the combustion chamber by bolts 42. The inner end of the burner nozzle extends through the head plate 41, and discharges into the combustion chamber so that the combustible gas mixture travels forwardly through the combustion chamber in a linear direction.

The combustion chamber includes an outer cylindrical wall 45 formed integrally with the head plate 41, and an inner cylindrical wall 46, the rear end of which is spaced from the head plate 41.

The inner wall 46 is formed from a heat resistant material such as stainless steel, so that the outer wall 45 is protected from the high heat of the gas flame.

It will be noted that since the burner discharges along the axis of the combustion chamber that the impingement of the hot flame directly against the walls is minimized, and that thereby hot spots will not develop, but that the heat transfer from the combustion zone of the heater to the air chamber around the combustion chamber is efficiently provided for.

The forward end of the combustion chamber connects into a series of tubes which terminates near the forward end of the heater unit, and is of a substantial length to provide for the travel of the hot gases in heat exchange relation with the outer annular chamber through which the air stream is forced by the blower.

The design of the heat exchanger per se is not a part of the present invention, but a satisfactory form thereof has been indicated in the drawing.

The inner element through which the hot gases move comprises a generally cylindrical wall 50, which opens into a series of radial tubes, which project into the air conduit. A cylindrical wall 51 spaced from the wall 50 provides the outer wall of the air conduit of the heat exchanger. Since the air stream traverses the surface of the tubes through which the heated gases move forwardly into a header at the forward end of the inner element of the heat exchanger, there is provided a substantial length of travel of the air stream with the heat exchange surface of the tubes through which the heated gases are required to travel, thus efficiently heating the air before it discharges into the space to be heated.

A vent pipe 53 is provided at the forward end of the gas section of the heat exchanger to evacuate the gas stream after it has traversed the length of the gas conduit section of the heat exchanger.

It is to be understood that the air stream discharges into the section of the casing 11 and is forced outwardly through the nozzle 12.

The heater is designed in such a manner as to be conveniently assembled by providing supports and connections for the several elements in their proper relationship, as well as providing means for the installation of the unit preferably in suspension as heretofore mentioned.

In order to provide a passage in front of the fan so that the air stream will enter the heated air conduit, the forward end of the air inlet ring 20 is connected with the outer wall 45 of the com-

bustion chamber where it joins the header plate 41 by a series of spaced metal straps 60, which may be welded to the margin of the plate 20 and to the exterior of the wall 45 of the combustion chamber. This provides for an air space forwardly of the fan, which connects into the air chamber around the combustion chamber.

The outer wall of the combustion chamber is supported in spaced relationship and to the outer shell by a radial series of rods 61, as indicated in Fig. 5 of the drawing.

In order to provide for mounting the heater in suspension, a series of longitudinally spaced ring members 62 are welded, or otherwise secured to the inner wall of outer casing 10. Welded or otherwise attached to each of said rings, are hanger clips 63 which project outwardly through slots 64 provided in casing 10.

In order to give strength to the support of the various elements by the rods 61, it is preferred to mount them so that their outer extremities are connected to the inner wall of the rear ring 62, as has been indicated particularly in Fig. 5.

In Fig. 1 there are indicated at 65 suspension rods, which have hooks formed at their lower end to engage into the openings in the hanger clips 63.

It will now appear from the foregoing description that there is provided a heater unit that accomplishes the objectives as set out in the foregoing part of this specification.

While I have described in detail certain of the structure, it should be understood that the invention is not limited except as expressed in the claims.

What is claimed is:

1. In a heater of the kind described, a cylindrical combustion chamber, a burner unit having a nozzle discharging linearly into said chamber, a casing surrounding and spaced from said combustion chamber and providing an annular air chamber around said combustion chamber, the casing having an air inlet positioned to admit external air to said air chamber at the same end as said nozzle and being further provided with an outlet, and a fan mounted for rotation on and supported by said nozzle to impel an air stream through said air chamber.

2. In a heater of the kind described, a cylindrical combustion chamber, a burner unit having a nozzle discharging linearly into said chamber, a casing surrounding and spaced from said combustion chamber and providing an annular air chamber around said combustion chamber, the casing having an air inlet positioned to admit external air to said air chamber at the same end as said nozzle and being further provided with an outlet, a fan mounted for rotation on and supported by said nozzle to impel an air stream through said air chamber, and a heat exchanger positioned forwardly of said combustion chamber including a gas chamber in heat exchange relation with the air chamber.

3. In a heater of the kind described, a tubular structure constituting a combustion chamber, a burner unit having a nozzle discharging linearly into said chamber along the axis thereof, a tubular casing spaced from and around said combustion chamber forming an air chamber outside the combustion chamber, the casing having an air inlet to admit external air at the same end of said air chamber as said nozzle and being further provided with an outlet, and a fan mounted for rotation on and supported by said nozzle to impel an air stream through said air chamber.

4. In a heater of the kind described, a tubular

5

structure constituting a combustion chamber, a burner unit having a nozzle discharging linearly into said chamber along the axis thereof, a tubular casing spaced from and around said combustion chamber forming an air chamber outside the combustion chamber, the casing having an air inlet to admit external air at the same end of said air chamber as said nozzle and being further provided with an outlet, a fan mounted for rotation on and supported by said nozzle to impel an air stream through said air chamber, a heat exchanger formed as an extension of said combustion chamber and within said air chamber in heat exchange relation thereto.

5. A heater of the class described, including an outer elongated casing, an inner elongated casing of less cross section than said outer casing having a header closing the inner end thereof, supporting means to maintain said casing in spaced relationship and thereby to form an outer air chamber having an inlet and an outlet around the inner casing, a burner unit having a nozzle entering through said header to said inner casing, an air inlet ring fitted into the inner end of said outer casing at the same end as said nozzle constituting the air inlet to said air chamber, and a fan mounted within said inlet and supported by said nozzle arranged to impel an air stream longitudinally through said air chamber in heat exchange relationship with the wall of said inner casing.

6. A heater of the class described, including an outer elongated casing, an inner elongated casing of less cross section than said outer casing having a header closing the inner end thereof mounted within said outer casing, the space between said casings forming an air chamber having an inlet and an outlet and said inner casing constituting a combustion chamber, a burner unit having a nozzle entering through said header to said combustion chamber, an air inlet ring fitted into the inner end of said outer casing at the same end as said nozzle constituting an air inlet passage to said air chamber, and a fan mounted within said inlet and supported by said nozzle arranged to impel an air stream longitudinally through said air chamber in heat exchange relationship with the wall of said inner casing.

7. A heater of the class described, including an outer elongated casing, an inner elongated casing of less cross section than said outer casing having a header closing the inner end thereof, said casings being in spaced relationship and thereby to form an outer air chamber around the inner casing and a combustion chamber, a burner unit having a nozzle entering through said header to said inner casing, the outer casing having an air inlet at the end of said outer casing to admit an air stream to said air chamber at the same end as said nozzle and being further provided with an outlet, and a fan mounted within said inlet and supported by said nozzle arranged to impel an air stream longitudinally through said air chamber in heat exchange relationship with the wall of said inner casing.

8. In a heater of the class described, the combination of means for forming a combustion chamber comprising inner and outer elongated tubular members arranged concentrically, a tubular outer casing spaced from said combustion chamber to provide an annular air passage in heat exchange relationship throughout the length of said combustion chamber, one end of said air passage having an air inlet at one end

6

thereof and the other end having an air outlet, a burner unit having a tubular nozzle discharging into said combustion chamber adjacent the air inlet end axially thereof, and a fan having a hub member mounted for rotation on said nozzle, said hub member carrying radial blades to impel an air stream through said air passage.

9. In a heater of the class described, the combination of means for forming a combustion chamber comprising inner and outer elongated tubular members arranged concentrically, a tubular outer casing spaced from said combustion chamber to provide an annular air passage in heat exchange relationship throughout the length of said combustion chamber one end of said air passage having an air inlet at one end thereof and the other end having an air outlet, means supporting said tubular members in spaced concentric relation, a burner unit having a tubular nozzle discharging into said combustion chamber axially thereof adjacent said air inlet end, and a fan having a hub member mounted for rotation on said nozzle said hub member carrying radial blades to impel an air stream through said air passage.

10. In a heater of the class described, the combination of means for forming a combustion chamber comprising inner and outer elongated tubular members arranged concentrically, a tubular outer casing spaced from said combustion chamber to provide an annular air passage in heat exchange relationship throughout the length of said combustion chamber one end of said air passage having an air inlet at one end thereof and the other end having an air outlet, a burner unit having a tubular nozzle discharging into said combustion chamber axially thereof adjacent said air inlet end, a fan having a hub member mounted on said nozzle, said hub member carrying radial blades to impel an air stream through said air passage, and supporting means including hanger clips adapted to support the heater in suspension.

11. A furnace construction including an elongated, closed, tubular combustion chamber, a head at one end and a flue outlet at the other, a tubular member connected through the head, and extending outwardly from the head, the tubular member being of a size to receive a burner head for directing a combustible mixture into the combustion chamber, a bearing outside the tubular member, a fan mounted on the bearing to rotate about the tubular member and direct air against the combustion chamber, casing means surrounding the combustion chamber provided with an inlet at one end adjacent the burner to receive the air from the fan and confine it around the chamber, the casing having an opening at the end of the combustion chamber remote from the fan, for the discharge of heated air.

PAUL MUELLER.

REFERENCES CITED

The following references are of record in the file of this patent:

UNITED STATES PATENTS

Number	Name	Date
2,363,168	Findley -----	Nov. 21, 1944
2,386,807	Leslie -----	Oct. 16, 1945
2,395,417	McCollum -----	Feb. 26, 1946
2,417,185	Williams -----	Mar. 11, 1947
2,417,315	McCollum -----	Mar. 11, 1947
2,517,398	McCollum -----	Aug. 1, 1950