



Europäisches Patentamt
European Patent Office
Office européen des brevets



(11) **EP 0 905 455 A1**

(12) **EUROPEAN PATENT APPLICATION**
published in accordance with Art. 158(3) EPC

- (43) Date of publication: **31.03.1999 Bulletin 1999/13**
(21) Application number: **98902248.8**
(22) Date of filing: **17.02.1998**
(51) Int. Cl.⁶: **F24F 5/00, F24F 13/08**
(86) International application number: **PCT/JP98/00636**
(87) International publication number: **WO 98/44299 (08.10.1998 Gazette 1998/40)**

- (84) Designated Contracting States:
BE DE ES FR GB GR IT NL PT
(30) Priority: **02.04.1997 JP 83759/97**
(71) Applicant:
Daikin Industries, Limited
Osaka-shi, Osaka 530-0015 (JP)
(72) Inventors:
• **ZHENG, Zhiming**
Kanoaka-kojo
Sakai-seisakusho,
Saikai-shi Osaka 591-8022 (JP)

- **SATO, Seiji**
Kanaoka-kojo
Sakai-seisakusho,
Sakai-shi Osaka 591-8022 (JP)
(74) Representative: **HOFFMANN - EITLÉ**
Patent- und Rechtsanwälte
Arabellastrasse 4
81925 München (DE)

(54) **OUTDOOR UNIT OF SEPARATE TYPE AIR CONDITIONER**

(57) An outdoor unit for use in an air conditioner has a propeller fan (2) disposed in a casing (1), and an outlet grille (4) disposed on an outlet side of the propeller fan (2). The outlet grille (4) has a square outlet opening (8) and has a plurality of blades (5) disposed in parallel with one another at given intervals in the outlet opening (8). With respect to a plane (P) which intersects with lines extending along lengths of the blades (5) at a given angle (θ) in a rotational direction of the fan and which includes the central axis of the fan (2), a difference exists between an inlet angle (α_A) of portions (5A) of the blades (5) positioned in an area (C₁) on one side of the plane (P) and an inlet angle (α_B) of portions (5B) of the blades (5) positioned in an area (C₂) on the other side of the plane (P).

Fig. 1

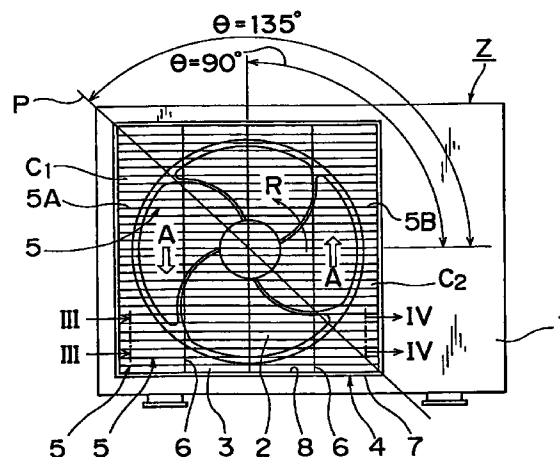

EP 0 905 455 A1

Description

TECHNICAL FIELD

[0001] The present invention relates to an outdoor unit for use in an air conditioner. More particularly, the invention relates to an outdoor unit for use in an air conditioner which unit comprises a propeller fan disposed in a casing and comprises an outlet grille disposed on the outlet side of the propeller fan.

BACKGROUND ART

[0002] Fig. 20 illustrates an outdoor unit Z_0 of a conventional air conditioner. The outdoor unit Z_0 has a heat exchanger (not shown) and a propeller fan 22 both disposed inside a casing 21 in the shape of a rectangle extending laterally, and has an outlet grille 25 fixed to a front opening 24 of the casing 21 on the outlet side of the propeller fan 22.

[0003] Essentially, an outlet grille in an outdoor unit is provided for preventing the danger that a man might touch a rotating fan, for preventing the breakage of the fan which might be caused by the intrusion of a foreign body into the unit, or for the like purpose. In recent years, however, rather than to such essential objects of the provision, increasing importance has been attributed to objects of the provision from viewpoints such as an improvement in the design of the outlet grille itself, an improvement in the appearance of the outdoor unit as a whole achieved by hiding the fan in the unit from a person's sight from diagonally above the unit, and an alteration to the direction of outgoing airflow in accordance with the location of the outdoor unit.

[0004] From such viewpoints, the outlet grille 25 takes the shape of a lattice as follows: The outlet grille 25 comprises an outer frame 28 having a square outlet opening 29 on the inside thereof, a plurality of blades 26, 26, ... extending laterally within the outer frame 28 and disposed in parallel with one another at given vertical intervals, and a plurality of support crosspieces 27, 27, ... vertically linking the blades 26, 26, ... to one another. In this arrangement, as shown in Figs. 21 and 22, the blades 26 have a comparatively wide cross section curved upward with respect to the direction from a front edge 26a facing the propeller fan 22 to a rear edge 26b on the outdoor side, so as to combine a good design and the function of hiding the inside of the unit and the function of deflecting outgoing airflow.

[0005] The outdoor unit Z_0 comprising the lattice-like outlet grille 25 as described above has the following problems.

[0006] In the case that the propeller fan 22 rotates in the direction of an arrow R (counterclockwise) to perform blow, as shown in Fig. 20, airflow forwarded from the propeller fan 22 toward the outlet grille 25 is counterclockwise swirl flow as shown by hollow arrows in the figure.

[0007] In this case, the airflow enters between the blades 26, 26, ... of the outlet grille 25 from above, in the left-side area in a view toward the propeller fan 22 in Fig. 20, while the airflow enters between the blades 26, 26, ... of the outlet grille 25 from below, in the right-side area in a view toward the propeller fan 22. The states of the airflow passing through the blades in both the areas are illustrated as airflow lines in Figs. 21 and 22, respectively.

[0008] In the case that, as shown in Fig. 21, airflow A having a downward component of velocity enters between the blades 26, the airflow A is greatly deflected upward by the blades 26, and airflow separation is therefore prone to occur on the lower surfaces (i.e., on the suction surfaces) of the blades 26, so that large vortexes are generated under the blades 26. In the case that, as shown in Fig. 22, airflow A having an upward component of velocity enters between the blades 26, airflow separation is prone to occur on the upper surfaces (i.e., on the suction surfaces) of the blades 26, so that large vortexes are generated over the blades.

[0009] As a result, an increase in the turbulence in the airflow outgoing from the outlet grille 25 causes an increase in aerodynamic noise which hinders the quiet operation of the outdoor unit, an increase in ventilating resistance at the outlet grille 25 which increases the load for driving the fan, and other problems.

[0010] It is a primary object of the present invention to provide an outdoor unit for use in an air conditioner which is capable of making as small as possible the turbulence in airflow at the outlet grille, so as to achieve the quiet operation and so as to reduce the load for driving the fan.

DISCLOSURE OF THE INVENTION

[0011] As specific means for resolving such problems, the invention employs the following arrangements:

[0012] The invention provides an outdoor unit for use in an air conditioner comprising a casing, a propeller fan disposed in the casing, and an outlet grille disposed on an outlet side of the propeller fan, the outlet grille having a substantially quadrilateral outlet opening and having a plurality of blades disposed in parallel with one another at given intervals in the outlet opening,

the outdoor unit for use in an air conditioner characterized in that, with respect to a plane which intersects with lines extending along lengths of the blades at a given angle in a rotational direction of the fan and which includes a central axis of the fan, a difference is provided between an inlet angle of portions of the blades positioned in an area on one side of the plane and an inlet angle of portions of the blades positioned in an area on the other side of the plane.

[0013] In the invention, the inlet angle of the portions of the blades positioned in the area on one side of the plane and the inlet angle of the portions of the blades positioned in the area on the other side of the plane can

be respectively conformed to the directions of influx of swirl flow from the propeller fan. For example, in the area where the direction of influx of the swirl flow is downward, the inlet angle of the portions of the blades positioned in the area is set upward; in the area where the direction of influx of the swirl flow is upward, the inlet angle of the portions of the blades positioned in the area is set downward. With this arrangement, airflow separation on the suction surfaces of the blades subjected to the airflow is effectively restrained, although the airflow from the propeller fan is the swirl flow and makes different the directions of influx of the airflow at the portions of the blades. Accordingly, the turbulence in the discharged airflow can be prevented as completely as possible throughout the outlet opening of the outlet grille. As a result, aerodynamic noises are reduced, so that quiet operation of the outdoor unit is achieved. Additionally, the ventilating resistance at the outlet grille is reduced, so that the load for driving the fan is reduced.

[0014] In accordance with an embodiment, with respect to the plane, a difference is provided between a chord length of the portions of the blades positioned in the area on the one side of the plane and a chord length of the portions of the blades positioned in the area on the other side of the plane.

[0015] In the outdoor unit for use in an air conditioner according to the embodiment, the chord length of the portions of the blades positioned in the area on one side of the plane and the chord length of the portions of the blades positioned in the area on the other side of the plane can be respectively conformed to the directions of influx of swirl flow from the propeller fan and to the direction of discharge from the outlet grille. For example, in the case that the direction of discharge from the outlet grille is set upward, the chord length of the portions of the blades positioned in the area where the direction of influx of the swirl flow is downward is set large to ensure a sufficient deflecting effect. Consequently, the airflow which has entered between the blades in the downward direction can be deflected sufficiently upward by the blades and thus can be discharged. On the other hand, the chord length of the portions of the blades positioned in the area where the direction of influx of the swirl flow is upward is set small to make the effect of deflecting the entering airflow as small as possible. Consequently, the airflow which has entered between the blades in the upward direction can be discharged upward through the blades just as it was. In the case that the direction of discharge from the outlet grille is set downward, leftward, or rightward, the similar arrangement corresponding to each direction is provided. As a result, airflow separation on the suction surfaces of the blades subjected to the airflow is effectively restrained, although the airflow from the propeller fan is the swirl flow and makes different the directions of influx of the airflow at the portions of the blades. Accordingly, the turbulence in the discharged airflow can be prevented as completely as possible throughout the outlet opening of the outlet grille.

As a result, aerodynamic noises are reduced, so that more quiet operation of the outdoor unit is achieved; additionally, the ventilating resistance at the outlet grille is reduced, so that the load for driving the fan is further reduced.

[0016] In accordance with an embodiment, the angle at which the plane intersects with the lines extending along the lengths of the blades is set within the range between 90° and 135°.

[0017] The airflow forwarded as swirl flow from the propeller fan travels from the rear edges of the propeller fan to the front edges of the blades while rotating in the area between the rear edges of the propeller fan and the front edges of the blades. In the outdoor unit for use in an air conditioner according to the embodiment, the plane generally coincides with the border between the area where the swirl flow actually enters between the front edges of the blades in a downward direction and the area where the swirl flow actually enters between the front edges of the blades in an upward direction, considering the angle through which the airflow rotates in the direction of the rotation of the fan between the instant when the airflow departs from the rear edges of the propeller fan and the instant when the airflow reaches the front edges of the blades. Accordingly, the above-mentioned effects of the invention can be achieved more reliably.

[0018] In accordance with an embodiment, shapes of rear edges toward the outside of the plurality of blades are the same throughout the outlet grille.

[0019] The outdoor unit for use in an air conditioner according to the embodiment achieves the above-mentioned effects of the invention and provides a good appearance in a view from the outside. Accordingly, the better appearance is achieved, the higher value of the outdoor unit as a commodity is expected.

[0020] In accordance with an embodiment, front edges of the plurality of blades are sawtoothed.

[0021] In the outdoor unit for use in an air conditioner according to the embodiment, a large number of small, vertical vortexes are generated from the roots of the sawteeth on the front edges of the blades, so that the airflow having high velocities of flow at large distances from the suction surfaces of the blades can be drawn close to the suction surfaces. Accordingly, airflow separation on the suction surfaces of the blades is effectively restrained, even though the inlet angles or chord length of the blades has a certain degree of deviation from the optimum values for the directions of influx of the airflow at the blade front edges. As a result, the above-mentioned effects of the invention are achieved more reliably.

[0022] In accordance with an embodiment, the sawtoothed shapes of the front edges of the blades are formed of a plurality of tapered projections.

[0023] In the outdoor unit for use in an air conditioner according to the embodiment, a large number of small, vertical vortexes are generated from the root of each

tapered projection, so that the airflow having high velocities of flow at large distances from the suction surface of the blade can be drawn close to the suction surface. Accordingly, airflow separation on the suction surface of the blade is effectively restrained, even though the inlet angles or chord length of the blade has a certain degree of deviation from the optimum values for the directions of influx of the airflow at the blade front edges. As a result, the above-mentioned effects of the invention are achieved more reliably.

[0024] In accordance with an embodiment, the tapered projections are shaped like right pyramids or right cones having apex portions thereof at the center of the thicknesses of the front edges of the blades.

[0025] With the outdoor unit for use in an air conditioner according to the embodiment, the deviation of the inlet angles or chord length of the blades from the optimum values for the directions of influx of the airflow at the blade front edges can be accommodated, whether the deviation is upward or downward. As a result, airflow separation on the suction surfaces of the blades is effectively and reliably restrained and the above-mentioned effects of the invention are thus achieved more reliably.

[0026] In accordance with an embodiment, the tapered projections are shaped like oblique pyramids or oblique cones having apex portions thereof in positions tilted in the direction of influx, relative to the center of the thicknesses of the front edges of the blades.

[0027] In the outdoor unit for use in an air conditioner according to the embodiment, airflow separation on the suction surfaces of the blades is effectively and reliably restrained by each tapered projection and the above-mentioned effects of the invention are thus achieved more reliably.

[0028] In accordance with an embodiment, the apex portions of the tapered projections are rounded.

[0029] With the outdoor unit for use in an air conditioner according to the embodiment, the tapered projections are readily manufactured and an improved safety in handling is ensured, as compared with the tapered projections shaped like spires.

[0030] In accordance with an embodiment, with the height of the tapered projections given as H and the chord length of the blade given as L, a ratio (H/L) of those values is set within the range between 0.05 and 0.35.

[0031] In this outdoor unit for use in an air conditioner, airflow separation on the suction surface of the blade is effectively and reliably restrained by each tapered projection and the above-mentioned effects of the invention are thus made more remarkable.

[0032] In accordance with an embodiment, with the pitch of the tapered projections given as S and the height of the tapered projections given as H, a ratio (S/H) of those values is set within the range between 0.5 and 1.5.

[0033] In the outdoor unit for use in an air conditioner

according to the embodiment, airflow separation on the suction surface of the blade is effectively and reliably restrained by each tapered projection and the above-mentioned effects of the invention are thus made more remarkable.

[0034] In accordance with an embodiment, with the pitch of the tapered projections given as S and the height of the tapered projections given as H, a ratio (S/H) of those values is set within the range between 0.7 and 1.3.

[0035] In the outdoor unit for use in an air conditioner according to the embodiment, airflow separation on the suction surface of the blade is effectively and reliably restrained by each tapered projection and the above-mentioned effects of the invention are thus made more remarkable.

[0036] In accordance with an embodiment, the casing and the outlet grille are formed so that a position in which the outlet grille is installed can be changed so as to turn the direction of the lengths of the blades about the central axis of the fan.

[0037] In the outdoor unit for use in an air conditioner according to the embodiment, the direction of discharge from the outlet grille can be changed into upward, transverse, and other directions as required, by changing the position in which the outlet grille is installed and thereby turning the direction of the lengths of the blades about the central axis of the fan. Accordingly, the ability of the outdoor unit at installation is improved.

[0038] The invention also provides an outdoor unit for use in an air conditioner comprising a casing, a propeller fan disposed in the casing, and an outlet grille disposed on an outlet side of the propeller fan, the outlet grille having a substantially quadrilateral outlet opening and having a plurality of blades disposed in parallel with one another at given intervals in the outlet opening,

the outdoor unit for use in an air conditioner characterized in that, with respect to a plane which intersects with lengths of the blades at a given angle in a rotational direction of the fan and which includes a central axis of the fan, a difference is provided between a chord length of portions of the blades positioned in an area on one side of the plane and a chord length of portions of the blades positioned in an area on the other side of the plane.

[0039] In the outdoor unit for use in an air conditioner according to the invention, the chord length of the portions of the blades positioned in the area on one side of the plane and the chord length of the portions of the blades positioned in the area on the other side of the plane can be respectively conformed to the directions of influx of swirl flow from the propeller fan and to the direction of discharge from the outlet grille. For example, in the case that the direction of discharge from the outlet grille is set upward, the chord length of the portions of the blades positioned in the area where the direction of influx of the swirl flow is downward is set large to ensure a sufficient deflecting effect. Consequently, the airflow

which has entered between the blades in the downward direction can be deflected sufficiently upward by the blades and thus can be discharged. On the other hand, the chord length of the portions of the blades positioned in the area where the direction of influx of the swirl flow is upward is set small to make the effect of deflecting the entering airflow as small as possible. Consequently, the airflow which has entered between the blades in the upward direction can be discharged upward through the blades just as it was. In the case that the direction of discharge from the outlet grille is set downward, leftward, or rightward, the similar arrangement corresponding to each direction is provided. As a result, airflow separation on the suction surfaces of the blades subjected to the airflow is effectively restrained, although the airflow from the propeller fan is the swirl flow and makes different the directions of influx of the airflow at the portions of the blades. Accordingly, the turbulence in the discharged airflow can be prevented as completely as possible throughout the outlet opening of the outlet grille. As a result, aerodynamic noises are reduced, so that quiet operation of the outdoor unit is achieved. Besides, the ventilating resistance at the outlet grille is reduced, so that the load for driving the fan is reduced.13

BRIEF DESCRIPTION OF THE DRAWINGS

[0040]

Fig. 1 is a front view of an outdoor unit for use in an air conditioner in accordance with a first embodiment of the invention;

Fig. 2 is a fragmentary perspective view of a blade in an outlet grille shown in Fig. 1;

Fig. 3 is an enlarged sectional view taken along the line III - III in Fig. 1;

Fig. 4 is an enlarged sectional view taken along the line IV - IV in Fig. 1;

Fig. 5 is a fragmentary perspective view of a blade in an outlet grille provided in an outdoor unit for use in an air conditioner in accordance with a second embodiment of the invention;

Fig. 6 is an enlarged sectional view along the line VI - VI illustrating a group of blades one of which is shown in Fig. 5;

Fig. 7 is an enlarged sectional view along the line VII - VII illustrating the group of blades one of which is shown in Fig. 5;

Fig. 8 is a fragmentary perspective view of a blade in an outlet grille provided in an outdoor unit for use in an air conditioner in accordance with a third embodiment of the invention;

Fig. 9 is an enlarged sectional view along the line IX - IX illustrating a group of blades one of which is shown in Fig. 8;

Fig. 10 is an enlarged sectional view along the line X - X illustrating the group of blades one of which is shown in Fig. 8;

Fig. 11 is a fragmentary perspective view of a blade in an outlet grille provided in an outdoor unit for use in an air conditioner in accordance with a fourth embodiment of the invention;

Fig. 12 is an enlarged sectional view along the line XII - XII illustrating a group of blades one of which is shown in Fig. 11;

Fig. 13 is an enlarged sectional view along the line XIII - XIII illustrating the group of blades one of which is shown in Fig. 11;

Fig. 14 is an enlarged view illustrating the structure of sawteeth in the blade shown in Fig. 11;

Fig. 15 is a representation illustrating noise characteristics on an outdoor unit comprising an outlet grille with the blade shown in Fig. 11;

Fig. 16 is a view illustrating noise characteristics on an outdoor unit comprising an outlet grille with the blade shown in Fig. 11;

Fig. 17 is a view illustrating air-volume/noise characteristics on the embodiments of the invention in comparison with a prior art;

Fig. 18 is a sectional view of a group of blades in an outlet grille provided in an outdoor unit for use in an air conditioner in accordance with a fifth embodiment of the invention;

Fig. 19 is a sectional view of a group of blades in the outlet grille provided in the outdoor unit for use in the air conditioner in accordance with the fifth embodiment of the invention;

Fig. 20 is a front view of a conventional outdoor unit;

Fig. 21 is an enlarged sectional view taken along the line XX - XX in Fig. 20; and

Fig. 22 is an enlarged sectional view taken along the line XXI - XXI in Fig. 20.

BEST MODE FOR CARRYING OUT THE INVENTION

[0041] Hereinafter, the invention will be described specifically on the basis of some preferred embodiments.

[0042] A first embodiment will now be described with reference to Figs. 1 to 4.

[0043] Fig. 1 illustrates an outdoor unit Z in accordance with the first embodiment of the invention. The outdoor unit Z has a basic arrangement similar to that of the aforementioned conventional outdoor unit, in which arrangement a propeller fan 2 and a heat exchanger (not shown) are disposed in a casing 1 so as to face a square front opening 3 provided in the front surface of the casing and in which an outlet grille 4 is removably secured to the front opening 3.

[0044] The outlet grille 4 has such a lattice-like shape as follows: The outlet grille 4 comprises an outer frame 7 having a substantially square outlet opening 8 on the inside thereof. In the outer frame 7, a plurality of blades 5, 5, ... each shaped like a strip are disposed in horizontal position and in parallel with one another at given vertical intervals, and the plurality of blades 5, 5, ... are

linked to one another by a plurality of support cross-pieces 6, 6, ... disposed in vertical position.

[0045] As shown in Figs. 2 to 4, each of the blades 5, 5, ... has basically a curved section and is installed with its concave surface upward. For the outlet grille 4, an installed position in which the blades 5 extend vertically may be optionally selected instead of the installed position in which the blades 5 extend horizontally in general as shown in Fig. 1. Accordingly, in the installed position shown in Fig. 1, the airflow having outgone from the propeller fan 2 is deflected upward by the blades 5, 5, ... and is then discharged from the unit; in an installed position in which, for example, the blades 5 extend vertically with the concave surfaces of the blades 5 faced to the left in a view toward the propeller fan 2, the airflow from the propeller fan 2 is discharged in a leftward direction.

[0046] As described above, each of the blades 5, 5, ... in the outlet grille 4 has a basic section similar to a section of a curved plate; in addition to such a basic section, this embodiment has different inlet angles of the blades 5, 5, ... in different areas defined according to the rotational direction of the propeller fan 2 and to the direction of the length of the blades 5, 5,

[0047] That is, in the embodiment as shown in Fig. 1, the whole area of the outlet opening 8 of the outlet grille 4 is divided into two areas C_1 and C_2 by an imaginary plane P (shown by a straight line in Fig. 1) including the central axis of the propeller fan 2, and the angle θ (measured with respect to the rotational direction of the fan) at which the plane P intersects with lines extending along the lengths of the blades 5 is set within the range between 90° and 135° (Fig. 1 illustrates the arrangement in which the angle θ of the intersection is 135°).

[0048] These areas are defined in consideration of the fact that airflow discharged from the propeller fan 2 is swirl flow forwarded along the rotational direction of the fan and in consideration of the amount of the turn of the swirl flow between the instant when the swirl flow departs from the rear edges of the blades of the propeller fan 2 and the instant when the swirl flow reaches the front edges of the blades 5, 5, ... of the outlet grille 4. In the first outlet area C_1 defined diagonally under the plane P, the airflow enters between the blades 5 in a downward direction as shown by a hollow arrow A; in the second outlet area C_2 defined diagonally over the plane P, the airflow enters between the blades 5 in an upward direction as shown by a hollow arrow A.

[0049] As shown in Fig. 2, each blade 5 is divided with respect to the direction of the length thereof into a first blade portion 5A positioned in the first outlet area C_1 and a second blade portion 5B positioned in the second outlet area C_2 so that an inlet angle α_A of a front edge 5Aa of the first blade portion 5A and an inlet angle α_B of a front edge 5Ba of the second blade portion 5B differ from each other. The specific arrangement is as shown in Figs. 3 and 4. That is, the inlet angle α_A of the front edge 5Aa of the first blade portion 5A positioned in the

first outlet area C_1 where the downward airflow enters is so set as to point upward relative to a horizontal line, according to the direction of influx of the airflow, so that the inlet angle α_A matches the direction of influx of the airflow as satisfactorily as possible. By contrast, the inlet angle α_B of the front edge 5Ba of the second blade portion 5B positioned in the second outlet area C_2 where the upward airflow enters is so set as to point downward relative to a horizontal line, according to the direction of influx of the airflow, so that the inlet angle α_B matches the direction of influx of the airflow as satisfactorily as possible.

[0050] Although the first blade portion 5A and the second blade portion 5B have different inlet angles α_A , α_B , as described above, the blade portions 5A and 5B have the same chord lengths L_A , L_B and the shapes of the rear edges 5Ab, 5Bb are also the same. Accordingly, the shapes of the rear edges of the blades 5, 5, ... are the same throughout the outlet grille 4 (i.e., throughout the outlet opening 8 of the outlet grille 4).

[0051] With this arrangement, the following specific operational effects can be obtained.

[0052] The inlet angle α_A of the first blade portion 5A and the inlet angle α_B of the second blade portion 5B are respectively conformed to the directions of influx of the swirl flow from the propeller fan 2; therefore, the directions of influx of the airflow match the inlet angles α_A and α_B of the blades 5 as completely as possible in the first outlet area C_1 and the second outlet area C_2 , respectively, and thus airflow separation is effectively restrained on the negative pressure (suction) surfaces of the blades 5 subjected to the airflow, although the airflow from the propeller fan 2 is the swirl flow and makes different the directions of influx of the airflow at the portions 5A, 5B of the blades 5. Accordingly, the turbulence in the discharged airflow can be prevented as completely as possible throughout the outlet opening 8 of the outlet grille 4. As a result, aerodynamic noises are reduced, so that quiet operation of the outdoor unit Z is achieved. Additionally, the ventilating resistance at the outlet grille 4 is reduced, so that the load for driving the fan is reduced.

[0053] In the plurality of blades 5, 5, ..., the first blade portions 5A and the second blade portions 5B have different inlet angles α_A , α_B but have the same shape in the rear edges 5Ab, 5Bb throughout the outlet grille 4, thus providing a good appearance in a view from the outdoor side. Accordingly, the better appearance is achieved, the higher value of the outdoor unit as a commodity is expected.

[0054] A second embodiment of the invention will be described below with reference to Figs. 5 to 7.

[0055] As an alternative to each blade 5 of the first embodiment, Fig. 5 illustrates a blade 5 (designated by the same numeral for convenience) provided in the outlet grille 4. Fig. 6 illustrates a sectional view of first blade portions 5A, 5A, ... of the blades 5, 5, ... arranged in the first outlet area C_1 , and Fig. 7 illustrates a sectional view

of second blade portions 5B, 5B, ... arranged in the second outlet area C_2 . The other elements of the outdoor unit Z are the same as those of the first embodiment.

[0056] In each blade 5 of the outlet grille 4 in this embodiment, as shown in the drawings, the first blade portion 5A and the second blade portion 5B have the same basic shape in section which is similar to a section of a curved plate and have the same inlet angles α_A , α_B , while the first blade portion 5A and the second blade portion 5B have different chord lengths L_A and L_B , respectively. That is, the chord length L_A of the first blade portion 5A positioned in the first outlet area C_1 is set large, while the chord lengths L_B of the second blade portion 5B positioned in the second outlet area C_2 is set small.

[0057] With this arrangement, the following specific operational effects can be obtained.

[0058] In the first outlet area C_1 where the direction of influx of the airflow from the propeller fan 2 is downward, the large chord length L_A of the first blade portion 5A ensures a sufficient effect of deflecting the airflow so that the airflow which has entered between the blades 5 in the downward direction can be deflected upward and thus can be discharged. In the second outlet area C_2 where the direction of influx of the airflow is upward, the small chord length L_B of the second blade portion 5B provides a decreased effect of deflecting the airflow so that the airflow which has entered between the blades 5 in the upward direction can be discharged upward from the blades just as it was.

[0059] Consequently, airflow separation is effectively restrained on the suction surfaces of the blades 5 subjected to the airflow, although the airflow from the propeller fan 2 is the swirl flow and makes different the directions of influx of the airflow at the portions 5A, 5B of the blades 5. Accordingly, the turbulence in the discharged airflow can be prevented as completely as possible throughout the outlet opening 8 of the outlet grille 4. As a result, aerodynamic noises are reduced, so that quiet operation of the outdoor unit is achieved; additionally, the ventilating resistance at the outlet grille is reduced, so that the load for driving the fan is reduced.

[0060] A third embodiment will be described below with reference to Figs. 8 to 10.

[0061] As an alternative to each blade 5 of the first embodiment, Fig. 8 illustrates a blade 5 (designated by the same numeral for convenience) provided in the outlet grille 4. Fig. 9 illustrates a sectional view of first blade portions 5A, 5A, ... of the blades 5, 5, ... arranged in the first outlet area C_1 , and Fig. 10 illustrates a sectional view of second blade portions 5B, 5B, ... arranged in the second outlet area C_2 . The other elements of the outdoor unit Z are the same as those of the first embodiment.

[0062] In each blade 5 of the outlet grille 4 in this embodiment, as shown in the drawings, the first blade portion 5A and the second blade portion 5B have the same basic shape in section which is similar to a section

of a curved plate, while the first blade portion 5A and the second blade portion 5B have different inlet angles α_A , α_B , and have different chord lengths L_A and L_B . That is, the inlet angle α_A of a front edge 5Aa of the first blade portion 5A positioned in the first outlet area C_1 where the airflow enters in a downward direction is so set as to point upward relative to a horizontal line, according to the direction of influx of the airflow, so that the inlet angle α_A matches the direction of influx of the airflow as satisfactorily as possible. By contrast, the inlet angle α_B of a front edge 5Ba of the second blade portion 5B positioned in the second outlet area C_2 where the airflow enters in an upward direction is so set as to point downward relative to a horizontal line, according to the direction of influx of the airflow, so that the inlet angle α_B matches the direction of influx of the airflow as satisfactorily as possible. Besides, the chord length L_A of the first blade portion 5A positioned in the first outlet area C_1 is set large, while the chord lengths L_B of the second blade portion 5B positioned in the second outlet area C_2 is set small.

[0063] As can be seen, this embodiment has both the characteristics of the blades of the first and second embodiments, so as to exert both the operational effects of the first embodiment and the operational effects of the second embodiment. Accordingly, more quiet operation of the outdoor unit is achieved and the load for driving the fan is reduced.

[0064] A fourth embodiment will be described below with reference to Figs. 11 to 16.

[0065] As an alternative to each blade 5 of the first embodiment, Fig. 11 illustrates a blade 5 (designated by the same numeral for convenience) provided in the outlet grille 4. Fig. 12 illustrates a sectional view of first blade portions 5A, 5A, ... of the blades 5, 5, ... arranged in the first outlet area C_1 , and Fig. 13 illustrates a sectional view of second blade portions 5B, 5B, ... arranged in the second outlet area C_2 . The other elements of the outdoor unit Z are the same as those of the first embodiment.

[0066] In each blade 5 of the outlet grille 4 in this embodiment, as shown in the drawings, elements comprising tapered projections 10, 10, ... are added to the basic structure of the blade 5 in the first embodiment.

[0067] The tapered projections 10, 10, ... are formed with a given pitch along the lengths of front edges 5Aa and 5Ba of blade portions 5A and 5B of the blade 5. The apex portion of each tapered projection 10 in this embodiment is shaped like a right pyramid positioned generally at the center of the thickness of the front edge 5Aa or 5Ba of the blade portion 5A or 5B. Such tapered projections 10, 10, ... are provided so that both the front edges 5Aa and 5Ba of the blade portions 5A and 5B have a sawtoothed shape.

[0068] When airflow from the propeller fan 2 enters between the front edges 5Aa, 5Ba of the blades 5, the tapered projections 10, 10, ... generate a large number of small, vertical vortexes from the roots of the tapered

projections 10, 10, ..., as shown by streamlines in Figs. 12 and 13, so that airflow having high velocities of flow at large distances from the negative pressure surface (the lower surface in the first blade portion 5A, or the upper surface in the second blade portion 5B) of each blade 5 can be drawn close to the negative pressure surface. Accordingly, airflow separation on the negative pressure surfaces of the blades 5 is effectively restrained, even though the inlet angles or chord length of the blades 5 has a certain degree of deviation from the optimum value(s) for the directions of influx of the airflow at the blade front edges 5Aa, 5Ba. As a result, the operational effects like the above embodiments are achieved more reliably.

[0069] In this embodiment, the tapered projections 10 shaped like regular cones accommodate the deviation of the inlet angles or chord length of the blades 10 from the optimum value(s) for the directions of influx of the airflow at the blade front edges 5Aa, 5Ba, whether the deviation is upward or downward, so that airflow separation on the negative pressure (suction) surfaces of the blades 5 is effectively restrained.

[0070] In order to most effectively and reliably achieve the specific operational effects of the tapered projections 10 as described above, it is necessary to provide an appropriate shape and the like for the tapered projections 10; the inventors have found such appropriate shape and the like by experiments.

[0071] As shown in Fig. 14, the chord length of the blade 5 is given as L, the height of the tapered projections 10 is given as H, and the pitch of the tapered projections 10, 10, ... is given as S. In the first place, the relation between the ratio of the height H of the tapered projections 10 to the chord length L of the blade 5 and noise level (i.e., one of the effects achieved by the restraint on airflow separation that the tapered projections 10 perform) was considered by experiment and, as shown by experimental data in Fig. 15, the ratios (H/L) between 0.05 and 0.35 were found to be most preferable.

[0072] Next, the relation between the ratio of the pitch S of the tapered projections 10, 10, ... to the height H of the tapered projections 10 and noise level was considered by experiment; as shown by experimental data in Fig. 16, the ratios (S/H) between 0.5 and 1.5 provided satisfactory results and the ratios (S/H) limited to the range between 0.7 and 1.3 were found to provide still better results.

[0073] Fig. 17 illustrates air-volume/noise characteristics on the above embodiments in comparison with a prior art. In Fig. 17, a symbol \bigcirc represents the characteristics of the prior art (Figs. 20 to 22); a symbol \triangle represents the characteristics in the case that the blades of the prior art each comprising the tapered projections 10, 10, ... were used; a symbol \square represents the characteristics of the first embodiment; and a symbol \bullet represents the characteristics of the fourth embodiment. It is observed from the experimental data that the invention

achieves quiet operation of the outdoor unit.

[0074] A fifth embodiment will be described below with reference to Figs. 18 and 19.

[0075] As to a plurality of blades 5, 5, ... provided in the outlet grille 4 in the fifth embodiment instead of the blades 5 of the first embodiment, Fig. 18 illustrates a sectional view of first blade portions 5A, 5A, ... arranged in the first outlet area C_1 , and Fig. 19 illustrates a sectional view of second blade portions 5B, 5B, ... positioned in the second outlet area C_2 . The blades 5 of this embodiment represent a modification to the blades 5 of the fourth embodiment. In the fourth embodiment, a plurality of tapered projections 10, 10, ... on the front edges 5Aa and 5Ba of each blade 5 are shaped like right pyramids; in the fifth embodiment, by contrast, a plurality of tapered projections 10, 10, ... on front edges 5Aa and 5Ba of each blade 5 are shaped like oblique pyramids. More specifically, the apex portions of the tapered projections 10, 10, ... are in positions tilted in the direction of influx of the airflow forwarded to the blade 5, relative to the center of the thickness of the front edges 5Aa and 5Ba of the blade 5.

[0076] With the tapered projections 10, 10, ... shaped like oblique pyramids in this manner, the directions of influx of the airflow from the propeller fan 2 can be matched with the inlet angles α_A and α_B of the blades 5 as completely as possible in the first outlet area C_1 and the second outlet area C_2 , respectively. Besides, airflow having high velocities of flow at large distances from the suction surface of each blade 5 can be drawn close to the suction surface; as the synergy between these effects, more quiet operation can be achieved and the load for driving the fan can be further reduced.

[0077] In the fourth embodiment, the tapered projections 10, 10, ... are provided on the front edges 5Aa and 5Ba of each blade 5 in which the first blade portion 5A and the second blade portion 5B have the same chord length and different inlet angles; however, the invention is not limited to such an arrangement. For example, the tapered projections 10, 10, ... may be provided on front edges 5Aa and 5Ba of each blade 5 in which a first blade portion 5A and a second blade portion 5B have the same inlet angle and different chord lengths. In this arrangement also, the quiet operation can be achieved and the load for driving the fan can be reduced.

[0078] In the fourth and fifth embodiments, the apex portion of each tapered projection 10 is shaped like a spire; however, the apex portion of each tapered projection 10 is not limited to such a shape but may be rounded. In the case that the apex portion of each tapered projection 10 is rounded, the tapered projections can be readily manufactured and an improved safety in handling is ensured, in comparison with the case that the apex portion is shaped like a spire.

[0079] The sawtoothed front edges 5Aa and 5Ba of each blade 5 may be formed, e.g., simply by cutting in a zigzagged manner the blade front edges 5Aa and 5Ba which have the curved basic sections of the first to third

embodiments, rather than by providing the tapered projections 10, 10, That is, the blade front edges 5Aa and 5Ba have only to be sawtoothed in order that the airflow having high velocities of flow at large distances from the suction surface of each blade 5 may be drawn close to the suction surface.

INDUSTRIAL APPLICABILITY

[0080] The outdoor unit for use in an air conditioner according to the invention can be preferably applied to an air conditioner, especially to an air conditioner of separate type having an indoor unit and an outdoor unit.

Claims

1. An outdoor unit for use in an air conditioner comprising a casing (1), a propeller fan (2) disposed in the casing (1), and an outlet grille (4) disposed on an outlet side of the propeller fan (2), the outlet grille (4) having a substantially quadrilateral outlet opening (8) and having a plurality of blades (5) disposed in parallel with one another at given intervals in the outlet opening (8),
the outdoor unit for use in an air conditioner characterized in that, with respect to a plane (P) which intersects with lines extending along lengths of the blades (5) at a given angle (θ) in a rotational direction of the fan (2) and which includes a central axis of the fan (2), a difference is provided between an inlet angle (α_A) of portions (5A) of the blades (5) positioned in an area (C_1) on one side of the plane (P) and an inlet angle (α_B) of portions (5B) of the blades (5) positioned in an area (C_2) on the other side of the plane (P).
2. An outdoor unit for use in an air conditioner as claimed in Claim 1, wherein, with respect to the plane (P), a difference is provided between a chord length (L_A) of the portions (5A) of the blades (5) positioned in the area (C_1) on the one side of the plane (P) and a chord length (L_B) of the portions (5B) of the blades (5) positioned in the area (C_2) on the other side of the plane (P).
3. An outdoor unit for use in an air conditioner as claimed in Claim 1 or 2, wherein the angle (θ) at which the plane (P) intersects with the lines extending along the lengths of the blades (5) is set within the range between 90° and 135° .
4. An outdoor unit for use in an air conditioner as claimed in Claim 1, 2 or 3, wherein shapes of rear edges (5Ab, 5Bb) toward the outside of the plurality of blades (5) are the same throughout the outlet grille (4).
5. An outdoor unit for use in an air conditioner as claimed in Claim 1, 2, 3 or 4, wherein front edges (5Aa, 5Ba) of the plurality of blades (5) are sawtoothed.
6. An outdoor unit for use in an air conditioner as claimed in Claim 5, wherein the sawtoothed shapes of the front edges (5Aa, 5Ba) of the blades (5) are formed of a plurality of tapered projections (10).
7. An outdoor unit for use in an air conditioner as claimed in Claim 6, wherein the tapered projections (10) are shaped like right pyramids or right cones having apex portions thereof at the center of the thicknesses of the front edges (5Aa, 5Ba) of the blades (5).
8. An outdoor unit for use in an air conditioner as claimed in Claim 6, wherein the tapered projections (10) are shaped like oblique pyramids or oblique cones having apex portions thereof in positions tilted in the direction of influx, relative to the center of the thicknesses of the front edges (5Aa, 5Ba) of the blades (5).
9. An outdoor unit for use in an air conditioner as claimed in Claim 6, 7 or 8, wherein the apex portions of the tapered projections (10) are rounded.
10. An outdoor unit for use in an air conditioner as claimed in Claim 6, 7, 8 or 9, wherein, with the height of the tapered projections given as H and the chord length of the blade (5) given as L, a ratio (H/L) of those values is set within the range between 0.05 and 0.35.
11. An outdoor unit for use in an air conditioner as claimed in Claim 6, 7, 8, 9, or 10, wherein, with the pitch of the tapered projections given as S and the height of the tapered projections given as H, a ratio (S/H) of those values is set within the range between 0.5 and 1.5.
12. An outdoor unit for use in an air conditioner as claimed in Claim 6, 7, 8, 9, or 10, wherein, with the pitch of the tapered projections given as S and the height of the tapered projections given as H, a ratio (S/H) of those values is set within the range between 0.7 and 1.3.
13. An outdoor unit for use in an air conditioner as claimed in Claim 1, 2, 3, 4, 5, 6, 7, a, 9, 10, 11 or 12, wherein the casing (1) and the outlet grille (4) are formed so that a position in which the outlet grille (4) is installed can be changed so as to turn the direction of the lengths of the blades (5) about the central axis of the fan (2).
14. An outdoor unit for use in an air conditioner com-

prising a casing (1), a propeller fan (2) disposed in the casing (1), and an outlet grille (4) disposed on an outlet side of the propeller fan (2), the outlet grille (4) having a substantially quadrilateral outlet opening (8) and having a plurality of blades (5) disposed in parallel with one another at given intervals in the outlet opening (8),

the outdoor unit for use in an air conditioner characterized in that, with respect to a plane (P) which intersects with lengths of the blades (5) at a given angle (θ) in a rotational direction of the fan (2) and which includes a central axis of the fan (2), a difference is provided between a chord length (L_A) of portions (5A) of the blades (5) positioned in an area (C_1) on one side of the plane (P) and a chord length (L_B) of portions (5B) of the blades (5) positioned in an area (C_2) on the other side of the plane (P).

5

10

15

20

25

30

35

40

45

50

55

Fig. 1

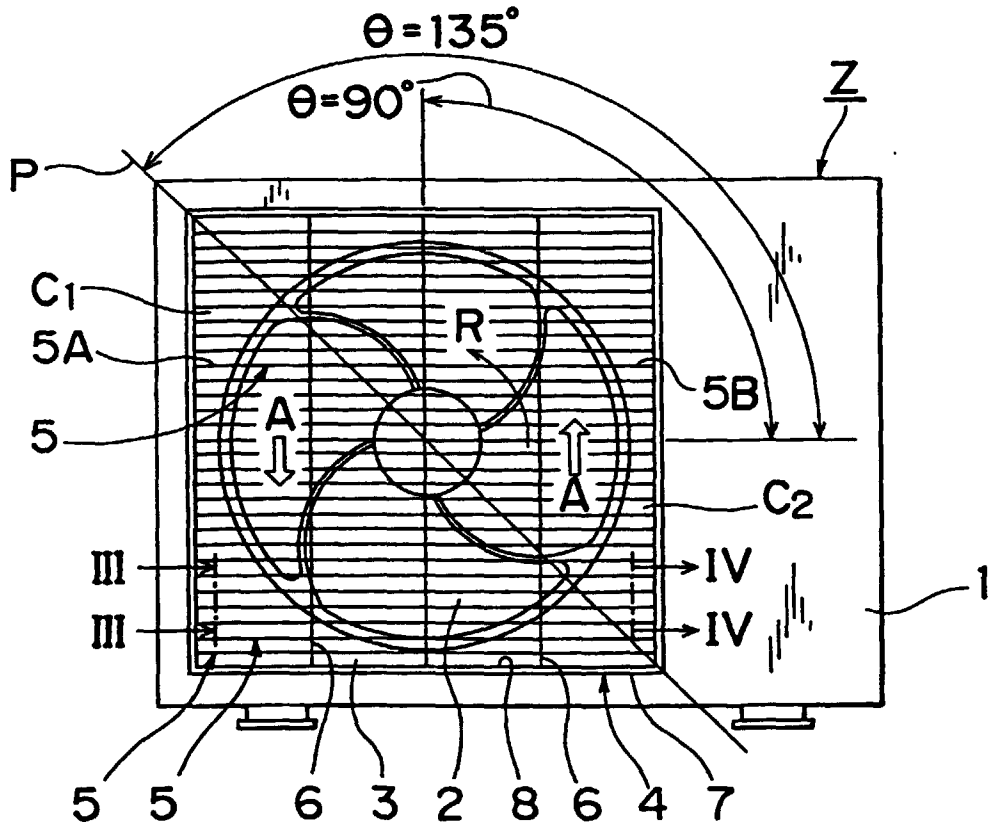

Fig. 2

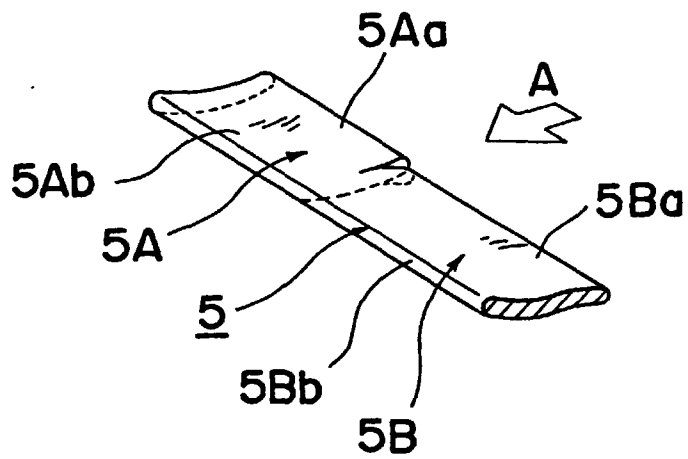

Fig. 3

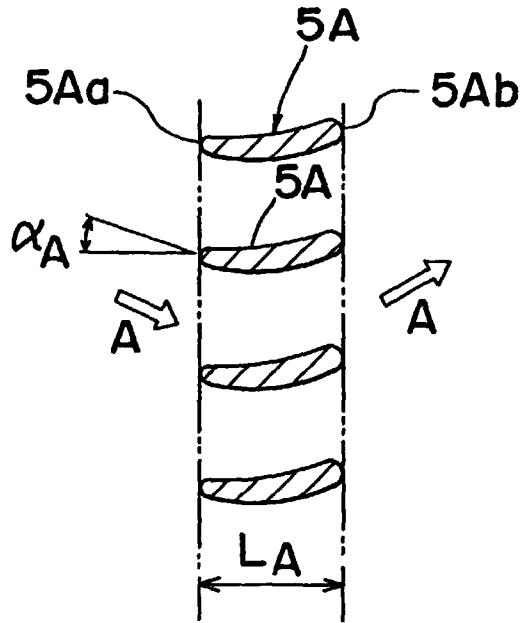

Fig. 4

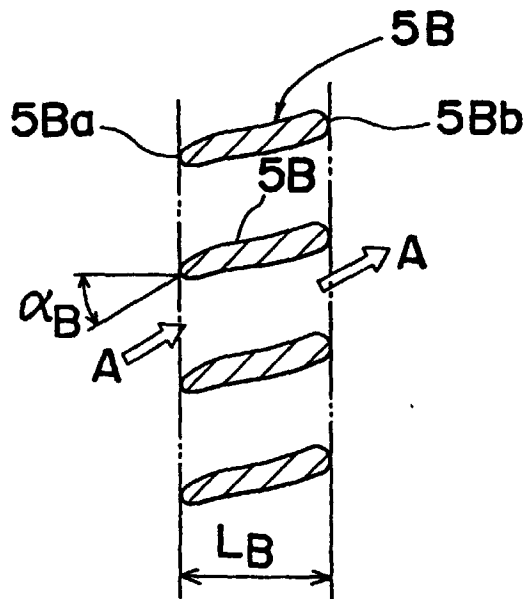

Fig.5

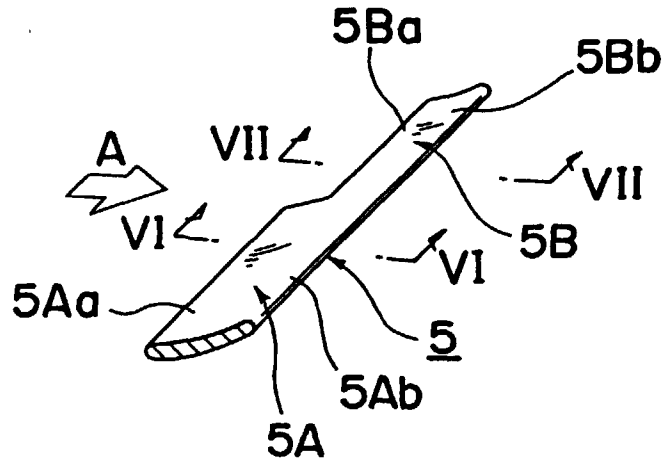

Fig.6

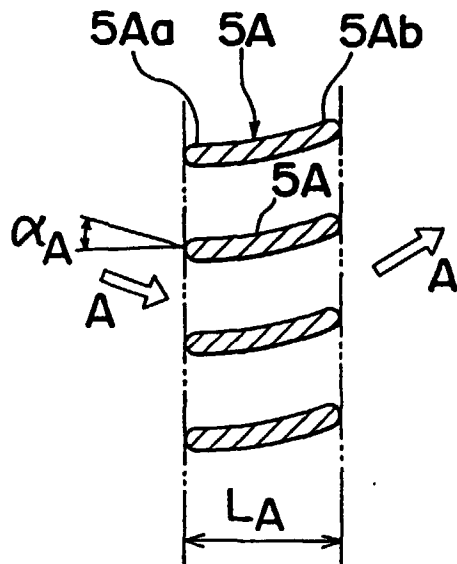

Fig. 7

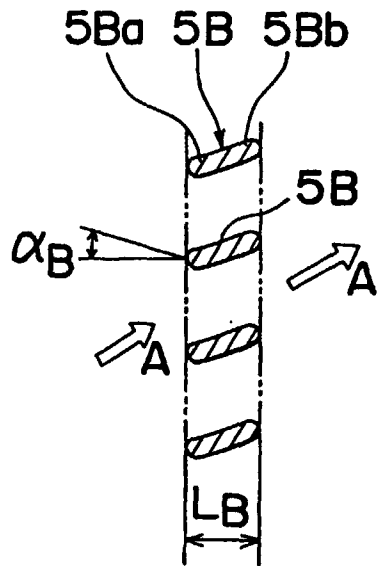

Fig. 8

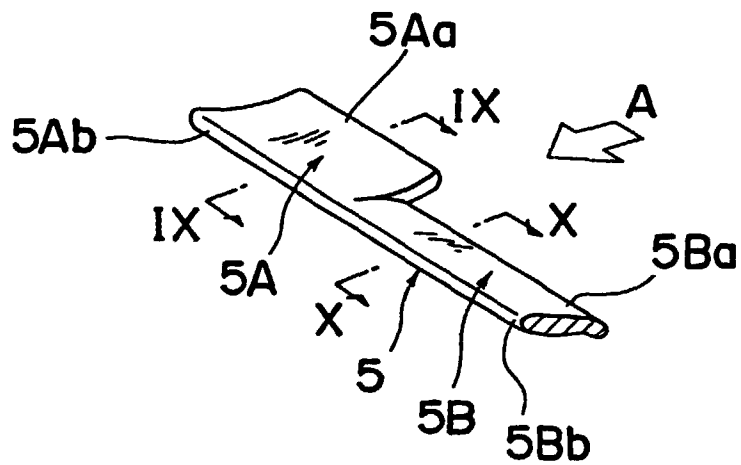

Fig.9

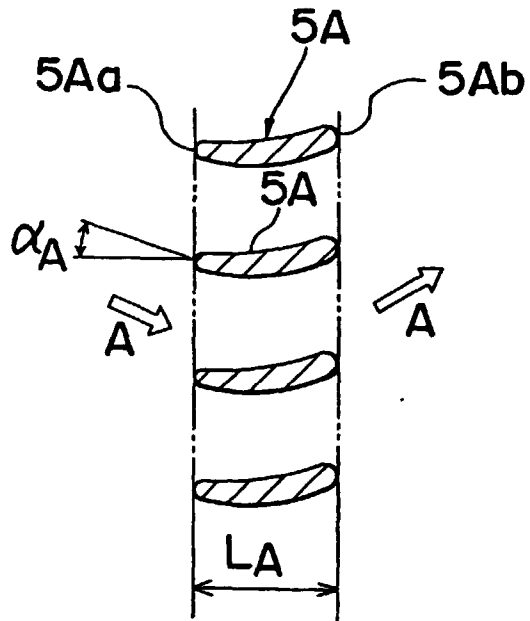

Fig.10

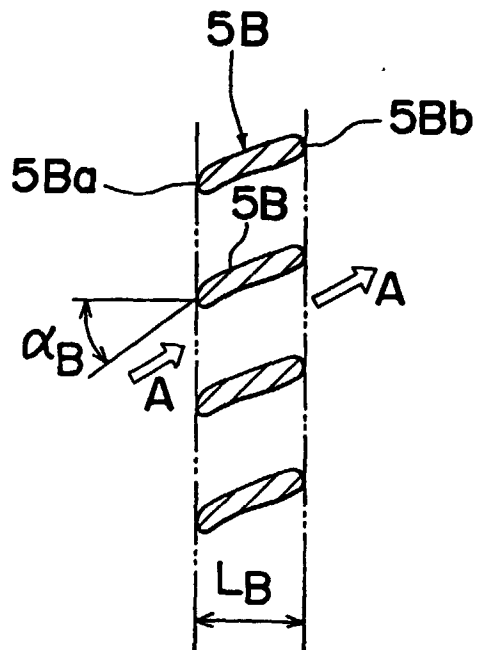

Fig.13

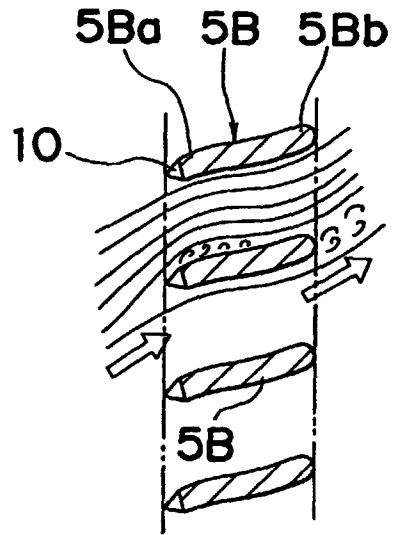

Fig.14

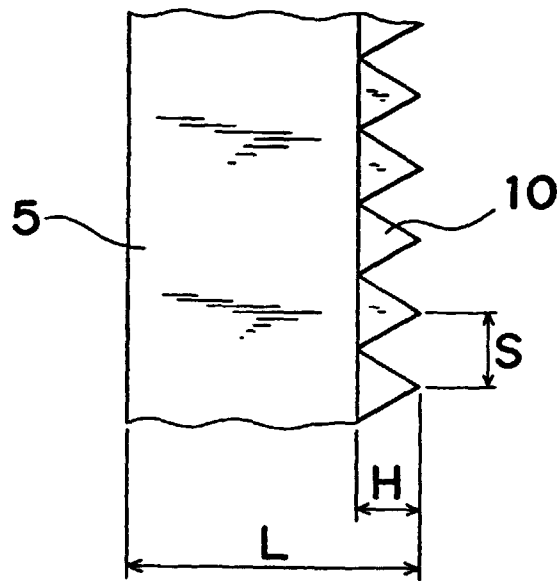

Fig. 15

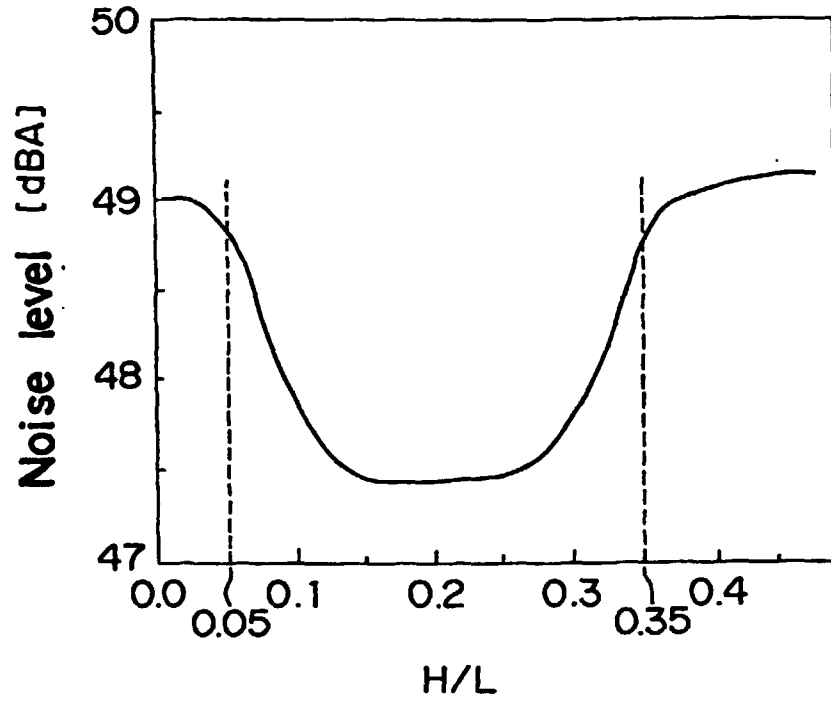

Fig. 16

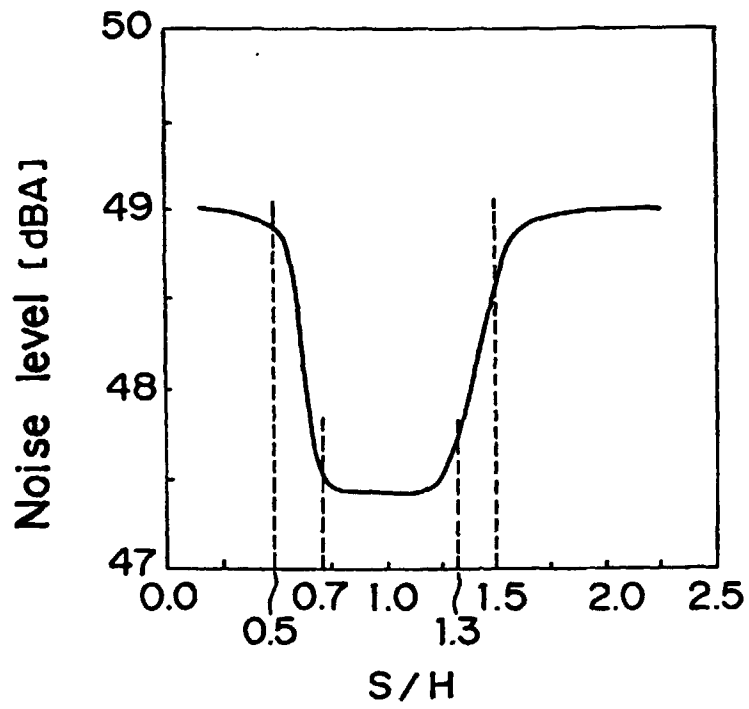

Fig.17

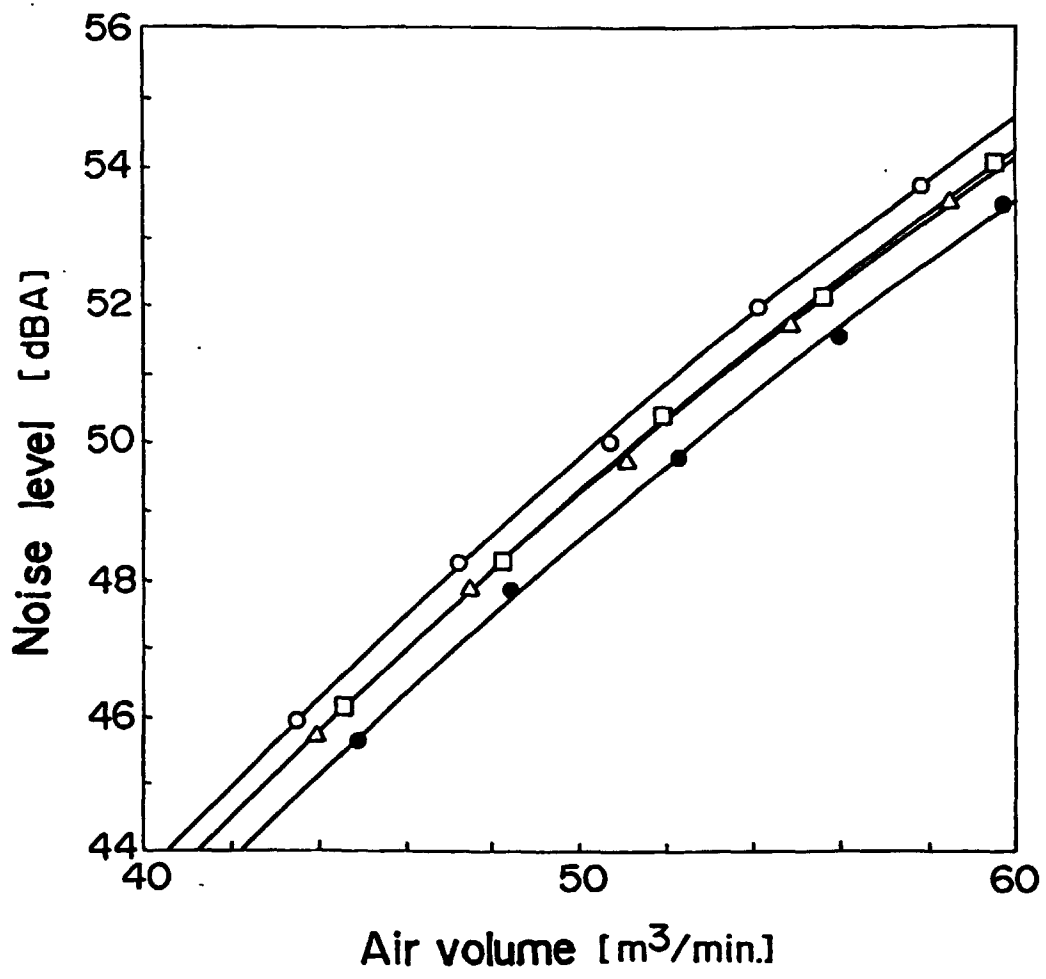

Fig.18

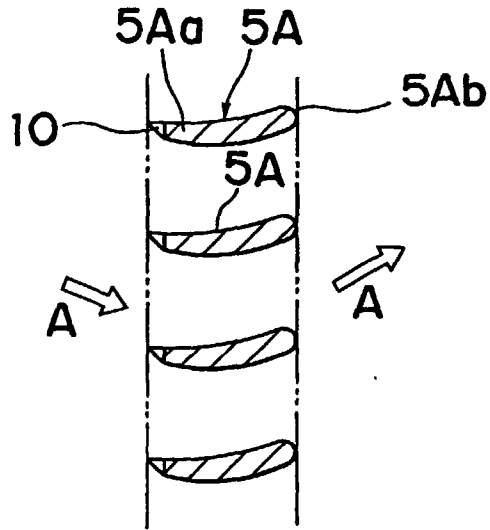

Fig.19

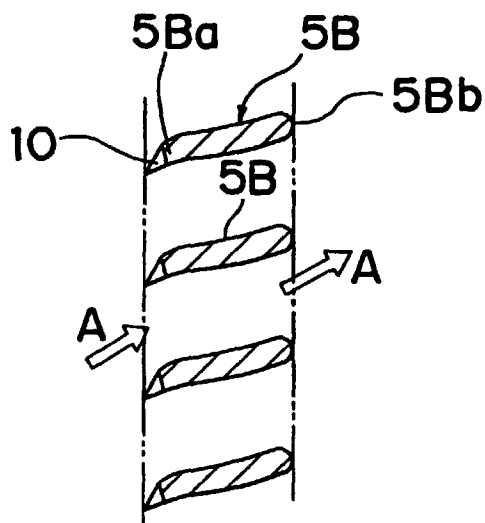

Fig. 20

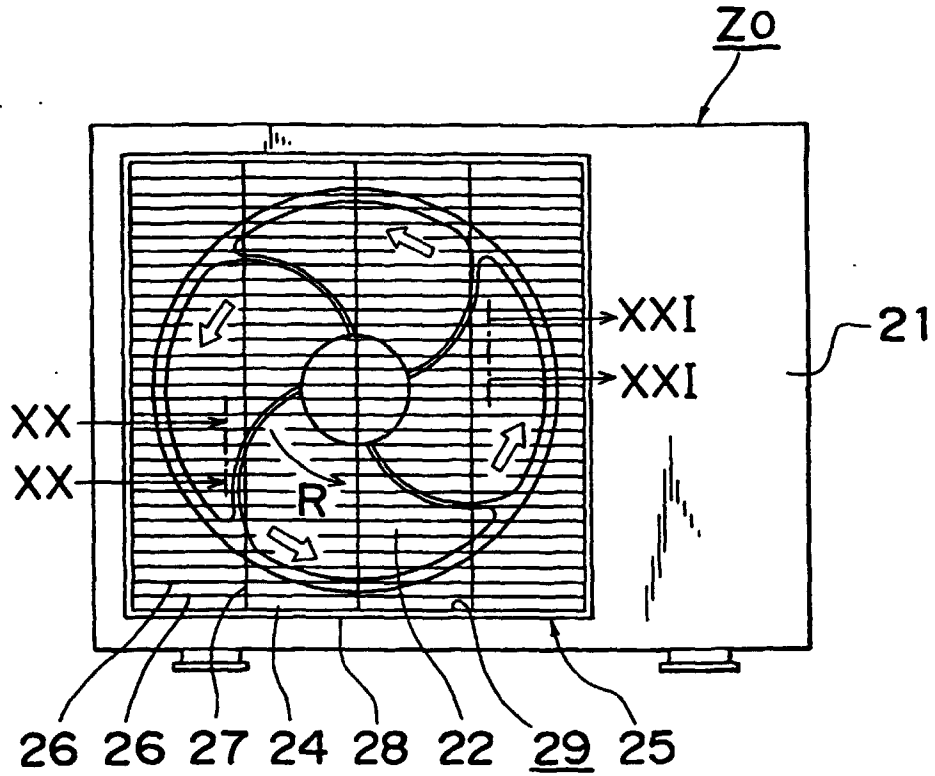

Fig. 21

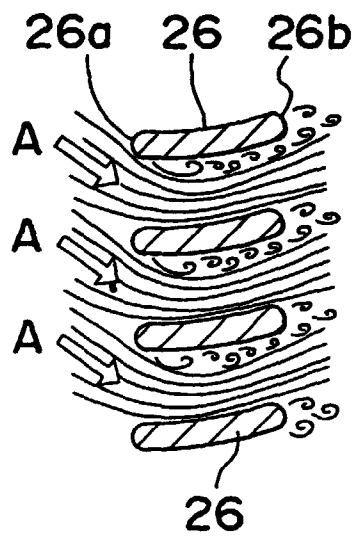
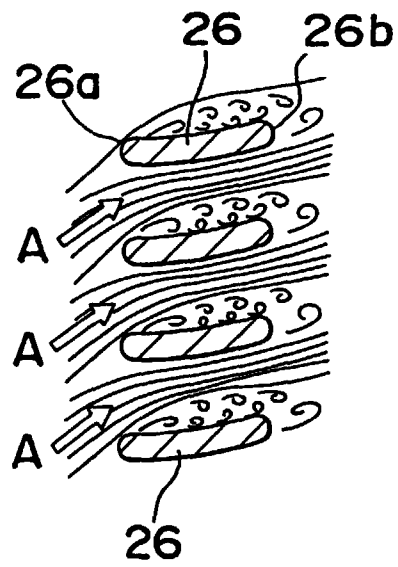

Fig.22



INTERNATIONAL SEARCH REPORT

International application No.

PCT/JP98/00636

A. CLASSIFICATION OF SUBJECT MATTER Int.Cl. ⁶ F24F5/00, F24F13/08		
According to International Patent Classification (IPC) or to both national classification and IPC		
B. FIELDS SEARCHED		
Minimum documentation searched (classification system followed by classification symbols) Int.Cl. ⁶ F24F5/00, F24F13/08		
Documentation searched other than minimum documentation to the extent that such documents are included in the fields searched Jitsuyo Shinan Koho 1926-1998 Toroku Jitsuyo Shinan Koho 1994-1998 Kokai Jitsuyo Shinan Koho 1971-1998		
Electronic data base consulted during the international search (name of data base and, where practicable, search terms used)		
C. DOCUMENTS CONSIDERED TO BE RELEVANT		
Category*	Citation of document, with indication, where appropriate, of the relevant passages	Relevant to claim No.
X	JP, 5-264070, A (Mitsubishi Electric Corp.), October 12, 1993 (12. 10. 93), Page 3, item Nos. 14 to 20 (Family: none)	1-4, 14
A	JP, 5-71766, A (Matsushita Electric Industrial Co., Ltd.), March 23, 1993 (23. 03. 93), Page 2, item No. 16 to page 3, item No. 19 (Family: none)	1-4
A	JP, 5-36220, U (Daikin Industries, Ltd.), May 18, 1993 (18. 05. 93) (Family: none)	13
<input type="checkbox"/> Further documents are listed in the continuation of Box C. <input type="checkbox"/> See patent family annex.		
* Special categories of cited documents: "A" document defining the general state of the art which is not considered to be of particular relevance "E" earlier document but published on or after the international filing date "L" document which may throw doubts on priority claim(s) or which is cited to establish the publication date of another citation or other special reason (as specified) "O" document referring to an oral disclosure, use, exhibition or other means "P" document published prior to the international filing date but later than the priority date claimed	"T" later document published after the international filing date or priority date and not in conflict with the application but cited to understand the principle or theory underlying the invention "X" document of particular relevance; the claimed invention cannot be considered novel or cannot be considered to involve an inventive step when the document is taken alone "Y" document of particular relevance; the claimed invention cannot be considered to involve an inventive step when the document is combined with one or more other such documents, such combination being obvious to a person skilled in the art "&" document member of the same patent family	
Date of the actual completion of the international search April 22, 1998 (22. 04. 98)	Date of mailing of the international search report May 12, 1998 (12. 05. 98)	
Name and mailing address of the ISA/ Japanese Patent Office	Authorized officer	
Facsimile No.	Telephone No.	

Form PCT/ISA/210 (second sheet) (July 1992)