



- (51) International Patent Classification:
A61M 5/145 (2006.01)
- (21) International Application Number:
PCT/US2016/037967
- (22) International Filing Date:
17 June 2016 (17.06.2016)
- (25) Filing Language: English
- (26) Publication Language: English
- (30) Priority Data:
62/180,938 17 June 2015 (17.06.2015) US
- (71) Applicant: SMITHS MEDICAL ASD, INC. [US/US];
6000 Nathan Lane North, Plymouth, MN 55442 (US).
- (72) Inventors: SANBORN, Jonathan; c/o Smiths Medical
Asd, Inc., 6000 Nathan Lane North, Plymouth, MN 55442
(US). RUKAVINA, John, P; c/o Smiths Medical Asd,
Inc., 6000 Nathan Lane North, Plymouth, MN 55442 (US).
ADAMS, Grant, A; c/o Smiths Medical Asd, Inc., 6000
Nathan Lane North, Plymouth, MN 55442 (US).
- (74) Agents: PATTERSON, James H. et al.; Patterson
Thuente Pedersen, P.A., 4800 IDS Center, 80 South Eight
Street, Minneapolis, MN 55402-2100 (US).

- (81) Designated States (unless otherwise indicated, for every kind of national protection available): AE, AG, AL, AM, AO, AT, AU, AZ, BA, BB, BG, BH, BN, BR, BW, BY, BZ, CA, CH, CL, CN, CO, CR, CU, CZ, DE, DK, DM, DO, DZ, EC, EE, EG, ES, FI, GB, GD, GE, GH, GM, GT, HN, HR, HU, ID, IL, IN, IR, IS, JP, KE, KG, KN, KP, KR, KZ, LA, LC, LK, LR, LS, LU, LY, MA, MD, ME, MG, MK, MN, MW, MX, MY, MZ, NA, NG, NI, NO, NZ, OM, PA, PE, PG, PH, PL, PT, QA, RO, RS, RU, RW, SA, SC, SD, SE, SG, SK, SL, SM, ST, SV, SY, TH, TJ, TM, TN, TR, TT, TZ, UA, UG, US, UZ, VC, VN, ZA, ZM, ZW.
- (84) Designated States (unless otherwise indicated, for every kind of regional protection available): ARIPO (BW, GH, GM, KE, LR, LS, MW, MZ, NA, RW, SD, SL, ST, SZ, TZ, UG, ZM, ZW), Eurasian (AM, AZ, BY, KG, KZ, RU, TJ, TM), European (AL, AT, BE, BG, CH, CY, CZ, DE, DK, EE, ES, FI, FR, GB, GR, HR, HU, IE, IS, IT, LT, LU, LV, MC, MK, MT, NL, NO, PL, PT, RO, RS, SE, SI, SK, SM, TR), OAPI (BF, BJ, CF, CG, CI, CM, GA, GN, GQ, GW, KM, ML, MR, NE, SN, TD, TG).

Published: — with international search report (Art. 21(3))

(54) Title: FORCE SENSING DEVICES, SYSTEMS AND METHOD FOR SYRINGE PUMPS

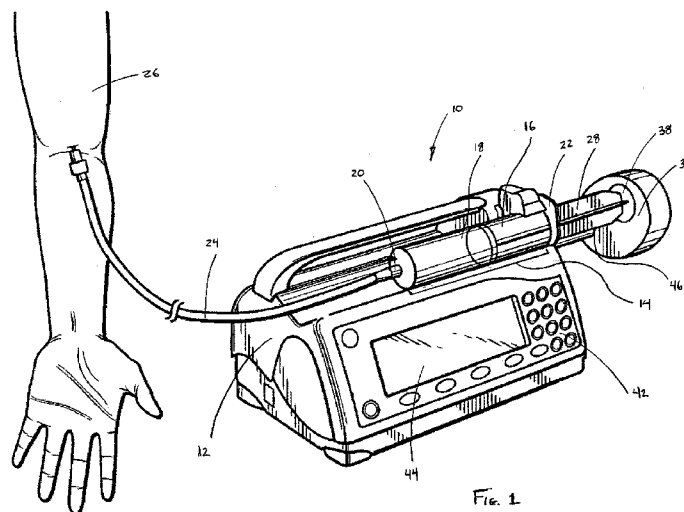

FIG. 1

(57) Abstract: A syringe pump configured to mechanically align a force sensor with an axis of a plunger of a syringe for a purpose of minimizing force measurement inaccuracies. The syringe pump includes a syringe pump housing that is configured to receive at least a portion of said syringe, wherein the syringe is selected from a plurality of syringes of different dimensions. A plunger retainer mechanism is pivotably coupled to the syringe pump housing and is configured to retain said plunger of said syringe. The plunger retainer mechanism pivots relative to the syringe pump housing based on a sensed dimension of the plunger to align a force sensor coupled to the plunger retainer mechanism with the axis of the plunger; and a syringe drive mechanism is operably coupled to the syringe pump housing and configured to shift the plunger relative to the portion of the syringe received by the syringe pump housing.

WO 2016/205584 A1

FORCE SENSING DEVICES, SYSTEMS AND METHODS FOR SYRINGE PUMPS**TECHNICAL FIELD**

The present disclosure relates generally to medical devices. More particularly, the present disclosure relates to force sensing devices, systems, and methods for syringe pumps.

BACKGROUND

Medical infusion pumps are used in a variety of medical therapies and treatments to administer drugs, nutritional compositions, and prescribed fluids or fluid-like substances (collectively, “medicaments” or “infusates”) to patients in volume- and time-controlled doses. Medicaments can be accurately and continuously administered by such pumps, at infusion rates typically ranging from as low as 0.1 ml/hr to as much as 1200 ml/hr. Because of their ability to deliver medicaments in a precise, accurate, and continuous manner, the types of medical infusion pumps commonly referred to as syringe pumps are well-suited to pain management and palliative care, for instance, and are also often useful in neonatal and pediatric intensive care units.

In operation, a medicament syringe includes a plunger that slideably, but tightly, fits inside of a cylindrical barrel which in turn contains a medicament. Medicament is administered from the cylindrical barrel by shifting the plunger through the cylindrical barrel. Medicament is thus expelled from the cylindrical barrel under pressure, through a delivery route comprising a needle, nozzle, tubing, or the like, directing the medicament to a patient. When a syringe is installed in a syringe pump, the plunger of the syringe in the pump can be acted upon by a plunger driver of the pump that functions to controllably expel medicament from the syringe for delivery to the patient as aforementioned. Medicament from a syringe in a syringe pump can be administered, for example, intravenously, intra-arterially, epidurally or subcutaneously. As will be appreciated, a constant and metered application of medicament requires a steady and accurate flow from the syringe in the syringe pump through the delivery route or path to the patient.

During the course of delivering the medicament to the patient, it is possible for an occlusion to arise in the delivery path. Examples of occlusions can include a closed stopcock, slider valve or pinched line or tubing leading to the patient. Such a condition, if undetected, can cause injury to the patient. That is, when an occlusion occurs along the delivery path, medicament may not be delivered to the patient even though the syringe pump apparently continues to function. Thus, an occlusion prevents the syringe pump from delivering medicament to the patient until the occlusion can be detected and cleared from the infusion path.

For this reason, the rapid detection of occlusions along the delivery path is important to reliable syringe pump operation.

An occlusion in the infusion line can cause a force, or pressure, in the syringe to increase. In turn, force between the plunger driver of the syringe pump and the plunger can increase. A force sensor can be placed in communication with the plunger driver, as shown, for example, in 5 U.S. Patent Nos. 7,635,349, 6,551,277, and 8,876,793, and in U.S. Patent App. Publ. No. 2015/0133890, each of which are incorporated by reference herein. A build up of pressure beyond normative operating ranges can accordingly be sensed, triggering alarms and initiating corrective action.

10 Many syringe pumps are capable of accommodating a range of syringe diameters or sizes (e.g., 1 ml through 60 ml capacities). Such a pump is disclosed, for example in the aforementioned U.S. Patent App. Publ. No. 2015/0133890 (U.S. Application No. 14/400,509) that is incorporated by reference herein. But in many syringe pumps, generally the plunger driver and force sensor can experience varying occlusion force vectors depending upon which 15 particular size of syringe is being used in the syringe pump, leading to varying accuracy and responsiveness overall in the pump's occlusion sensing system. One source of inaccuracy arises from misalignment of the force sensor with an axis of the plunger in the syringe. In particular, the force sensor may be aligned with the plunger in some syringe diameters or sizes when installed in the pump; but such desirable alignment of the force sensor with the plunger of the 20 syringe might not occur when a syringe of another diameter or size is installed in the pump. Consequently, providing axial alignment of the force sensor with the axis of the plunger, or compensating for misalignment thereof, can provide improvement in the accuracy of force measurement.

25 A syringe pump that is capable of aligning the force sensor with the axis of a plunger of a syringe installed in the pump, across a range of syringe diameters or sizes, would therefore provide a distinct advantage in minimizing force measurement inaccuracy.

SUMMARY OF THE DISCLOSURE

30 Embodiments of the present disclosure meet a need of the industry for force sensing devices, systems, and methods for syringe pumps that provide axial alignment of the force sensor with an axis of the plunger, or compensating for misalignment thereof.

In an embodiment, a syringe pump includes a force sensor with an articulating plunger retainer mechanism, wherein the plunger retainer mechanism can be positioned to align the force sensor with the axis of a plunger of a syringe from a range of syringe diameters or sizes for the

purpose of minimizing force measurement inaccuracies. In addition to improving accuracy, by aligning the force sensor with the axis of the plunger, bending of the plunger during operation is minimized, binding of the sensor is minimized, and a need for software to compensate for off-axis errors can be reduced or eliminated.

5 A first embodiment of the present disclosure and subject matter hereof provides a syringe pump that is capable of mechanically aligning a force sensor with an axis of a plunger of a syringe for a purpose of minimizing force measurement inaccuracies. In an embodiment, the syringe pump includes a syringe pump housing, a plunger retainer mechanism, and a syringe drive mechanism. The syringe pump housing is configured to receive at least a portion of the
10 syringe, wherein the syringe is selected from a plurality of syringes of different dimensions. The plunger retainer mechanism is pivotably coupled to the syringe pump housing and configured to retain the plunger of the syringe. The plunger retainer mechanism is capable of pivoting relative to the syringe pump housing based on a sensed dimension of the plunger to align a force sensor coupled to the plunger retainer mechanism with the axis of the plunger. The syringe drive
15 mechanism is operably coupled to the syringe pump housing and is configured to shift the plunger relative to a barrel of the syringe, thereby administering a medicament from the syringe.

 A second embodiment of the present disclosure and subject matter hereof includes a syringe pump housing, a plunger retainer mechanism, and a syringe drive mechanism. The plunger retainer mechanism includes a force sensor that is shiftably coupled to the plunger
20 retainer mechanism, thereby enabling movement of the force sensor along a linear path relative to the plunger retainer mechanism to align the force sensor with the axis of a plunger in a barrel of a syringe that is installed in or on the syringe pump housing.

 A third embodiment of the present disclosure and subject matter hereof includes a syringe pump housing, a plunger retainer mechanism, and a syringe drive mechanism. The plunger
25 retainer mechanism includes a force sensor and one or more thumb press captures. In this embodiment, the force sensor is operably coupled to the one or more thumb press captures, so that when the force sensor shifts along a linear path relative to the plunger retainer mechanism to align the force sensor with the axis of a plunger in a barrel of a syringe that is installed in or on the syringe pump housing, the one or more thumb press captures pivot relative to the plunger
30 retainer mechanism to retain a thumb press of the plunger of the syringe. In this embodiment, the force sensor is substantially aligned with the axis of the plunger when the one or more thumb press captures abut the thumb press of the plunger of the syringe.

The summary above is not intended to describe each illustrated embodiment or every implementation of the present disclosure and subject matter hereof. The figures and the detailed description that follow more particularly exemplify these embodiments.

5

BRIEF DESCRIPTION OF THE DRAWINGS

The disclosure and subject matter hereof can be more completely understood in consideration of the following detailed description of various embodiments of the disclosure and subject matter hereof, in connection with the accompanying drawings, in which:

10 FIG. 1 is a perspective view depicting a syringe pump in accordance with an embodiment of the disclosure.

FIG. 2 is a schematic view depicting a syringe pump in accordance with an embodiment of the disclosure.

15 FIG. 3A is a plan view depicting a plunger retainer mechanism in accordance with a first embodiment of the disclosure, wherein arms of the plunger retainer mechanism are engaging a relatively small diameter syringe.

FIG. 3B is a plan view depicting the plunger retainer mechanism of FIG. 3A, wherein the arms are engaging a relatively large diameter syringe.

FIG. 4 is a schematic view depicting the plunger retainer mechanism of FIGS. 3A-B throughout a range of motion to accommodate syringes of varying diameters or sizes.

20 FIG. 5 is a plan view depicting a gear assembly of a plunger retainer mechanism in accordance with a first embodiment of the disclosure.

FIG. 6 is a plan view depicting a plunger retainer mechanism in accordance with a second embodiment of the disclosure.

25 FIG. 7 is a plan view depicting a plunger retainer mechanism in accordance with a third embodiment of the disclosure.

30 While embodiments of the disclosure are amenable to various modifications and alternative forms, specifics thereof are shown by way of example in the drawings and will be described in detail. It should be understood, however, that the intention is not to limit the disclosure to the particular embodiments described. On the contrary, the intention is to cover all modifications, equivalents, and alternatives falling within the spirit and scope of the disclosure as defined by the appended claims.

DETAILED DESCRIPTION

Referring to FIGS. 1-2, syringe pumps 10 (collectively, pump 10) in accordance with an embodiment of the disclosure are depicted. Pump 10 includes an outer housing 12 with a cradle, nest or recess 14 on a surface shaped to receive a syringe 16 of conventional kind. Syringe 16 has a cylindrical barrel 18 with an outlet or tip 20 at its forward end and a flange or ear 22 at its rear end. Tip 20 is connected to infusion tubing or line 24 so that medicament in syringe 16 can be dispensed to a patient 26 via infusion line 24.

Pump 10 has a syringe drive mechanism, such as including a lead screw 32 driven by a motor 34. The syringe drive mechanism is operably coupled to housing 12 and is configured to shift plunger 28 relative to cylindrical barrel 18, to controllably force medicament out tip 20 and into infusion line 24 so that medicament can be delivered to patient 26. In an embodiment, a syringe drive mechanism is coupled with a plunger retainer mechanism 36 for engaging a thumb press 38 of plunger 28. Motor 34 is driven by a control unit 40, which receives inputs from a keypad 42, or other user input means, and various sensors. Control unit 40 also provides an output to a display 44.

Referring to FIGS. 3A-3B, a plunger retainer mechanism 36 in accordance with a first embodiment of the disclosure and subject matter hereof is depicted. In an embodiment, plunger retainer mechanism 36 is pivotably coupled to syringe pump housing 12 by pivot mount 46. Plunger retainer mechanism 36 includes a frame 52 supporting one or more arms 48 each pivotably mounted to frame 52 by a pivot 50. For instance, as depicted in FIGS. 3A-3B, plunger retainer mechanism 36 can include three arms 48. In other embodiments, the plunger retainer mechanism 36 can include one, two, four, or any number of arms 48. In an embodiment, arms 48 are configured to pivot so as to abut a portion of a syringe 16 (not depicted in FIGS. 3A-3B) when syringe 16 is installed in or coupled to syringe pump 10 or otherwise loaded or positioned in recess 14 of pump 10 (as depicted in FIGS. 1 and 2). For example, in an embodiment, arms 48 are configured to pivot to removably but securely engage plunger 28 and/or thumb press 38, thereby removably but securely coupling plunger 28 and/or thumb press 38 to plunger retainer mechanism 36.

In an embodiment, plunger retainer mechanism 36 includes at least one force sensor 54. Force sensor 54 can be, for instance, a model FX1901 Force Sensor, available from Measurement Specialties, 1000 Lucas Way, Hampton, VA 23666 www.meas-spec.com. Generally, sensors of this type are constructed from either a thin foil material or a glass substrate that has been metalized, such as a silicon wafer. In an embodiment, force sensor 54 is centrally

located between arms 48 and pivots 50. For instance, force sensor 54 can be positioned at substantially equal distance from each pivot 50.

In an embodiment, arms 48 are operably coupled to one another, so that when more than one arm 48 is included in plunger retainer mechanism 36, arms 48 pivot in unison to cooperatively and correspondingly engage various portions of plunger 28 and/or thumb press 38 and thereby retain plunger 28 and/or thumb press 38 at multiple points around a perimeter of syringe 16, while ensuring that plunger 28 is axially aligned with force sensor 54. In an embodiment, this is accomplished through a so-called sun and planetary gear system. For instance, as depicted in FIG. 5, each arm 48 is fixedly coupled to a segment planetary gear 58 which interacts with a central sun gear 56. Accordingly, arms 48 are configured to grip a range of sizes or diameters of syringe plungers 28 and/or thumb presses 38. For instance, in an embodiment, plunger retainer mechanism 36 is configured to retain syringes 16 (not depicted in FIG. 5) having an internal volume of between 1mL and 60mL.

In an embodiment, arms 48 are operably coupled with pivot mount 46, such that when arms 48 pivot, plunger retainer mechanism 36 pivots with respect to syringe pump housing 12. By coupling the pivoting of arms 48 with the pivoting of plunger retainer mechanism 36, arms 48 can constrict around plunger 28 and or thumb press 38, while enabling syringe 16 to remain axially aligned in recess 14. In an embodiment, this is accomplished through a series of gears. For instance, as depicted in FIG. 5, sun gear 56 can be fixedly coupled to a larger diameter gear 60, which can interact with a series of gears 62, 64, and 66 to pivot plunger retainer mechanism 36 about pivot mount 46. Accordingly, as depicted in FIG. 4, in an embodiment, plunger retainer mechanism 36 can vary its angular position relative to an axial alignment of syringe 16 in recess 14 along an angle θ to thus maintain a desirable coaxial alignment of syringe 16, recess 14 and force sensor 54 throughout a range of sizes and diameters of syringes 16 installed in pump 10 (not depicted in FIG. 4). For example, in an embodiment, angle θ can be substantially equal to 14.23 degrees, thereby enabling force sensor 54 to traverse an arc representing an axial center of plunger 28 resulting from a range of syringe diameters or sizes. In an embodiment, the arc can measure approximately 0.5 inches in length.

Referring again to FIG. 5, collectively, gears 56, 58, 60, 62, 64, and 66 can be referred to as a gear assembly 70. Accordingly, gear assembly 70 enables plunger retainer mechanism 36 to rotatably align itself with an axial center of syringe 16 as it grips plunger 28 and/or thumb press 38 for retention in pump 10, thereby ensuring that force sensor 54 is coaxially aligned with forces applied by the syringe drive mechanism to plunger 28 during operation. In an embodiment, gear assembly 70 can be operably coupled with a motor, an actuator, or a manual

drive mechanism 68 to actively pivot arms 48 and plunger retainer mechanism 36 into an intended position. The drive mechanism can cease driving gear assembly 70 when arms 48 contact plunger 28 and/or thumb press 38 of syringe 16. For instance, in an embodiment, when resistance of arms 48 against plunger 28 and/or thumb press 38 is sensed, the drive mechanism ceases driving gear assembly 70.

In operation, when syringe 16 is installed in syringe pump 10, the drive mechanism will be in an extended position (away from housing 12 of pump 10, or toward a right side of FIGS. 1 and 2) and plunger retainer mechanism 36 will be rotated about pivot mount 46 to an open position. Thus, arms 48 of plunger retainer mechanism 36 are positioned by way of gear assembly 70 to minimize interference with plunger 28 and/or thumb press 38 as syringe 16 is loaded or installed in pump 10. When syringe 16 is then loaded or installed in recess 14 of housing 12 of pump 10, plunger retainer mechanism 36 is rotated to a retention position until resistance of arms 48 against plunger 28 and/or thumb press 38 is sensed. This causes arms 48 to grip a portion of plunger 28 and/or thumb press 38 as aforescribed, while assisting to keep barrel 18 of syringe 16 aligned with recess 14. In some embodiments, pressing a load button on keypad 42 causes the drive mechanism to actively pivot arms 48 and plunger retainer mechanism 36 into a retention position, thereby ensuring that force sensor 54 is axially aligned with plunger 28. In another embodiment, plunger retainer mechanism 36 is moved manually or by other means. The syringe drive mechanism is adjusted as necessary to ensure proper loading or installing of syringe 16 in pump 10.

When removing syringe 16 from pump 10, the syringe drive mechanism is rotated in an opposite direction, thereby pivoting arms 48 to release a portion of plunger 28 and/or thumb press 38 that had been retained between arms 48 and plunger retainer mechanism 36. Syringe 16 can then be removed from recess 14.

Referring to FIG. 6, a plunger retainer mechanism 36' in accordance with a second embodiment of the disclosure and subject matter hereof is depicted. In this embodiment, plunger retainer mechanism 36' is operably coupled to syringe pump housing 12 by mount 74; however, unlike the first embodiment plunger retainer mechanism 36, this second embodiment of plunger retainer mechanism 36' need not pivot with respect to syringe pump housing 12. Instead, in this embodiment, to enable alignment with plunger 28 of a range of syringe diameters or sizes, force sensor 54 is shiftable along a linear path 80.

In this second embodiment, plunger retainer mechanism 36' includes a frame 52 supporting a movable element 76 and a drive mechanism 78. In an embodiment, moveable element 76 is operably coupled to frame 52 by a slideable connector, such as a track and clip

assembly (not depicted), that enables moveable element 76 to traverse along a substantially linear path 80 relative to frame 52. In an embodiment, drive mechanism 78 can be a motor, for example, a stepper motor. Movable element 76 can include a toothed rack 84 for interaction with a pinion gear 86 coupled to drive mechanism 78, thereby enabling element 76 to be driven forwardly or backwardly into a desired position 82 along linear path 80. Force sensor 54 can be fixedly coupled to movable element 76, thereby enabling axial alignment of plunger 28 (not depicted in FIG. 6) of a range of syringe diameters or sizes, with force sensor 54 along linear path 80.

Referring to FIG. 7, a plunger retainer mechanism 36'' in accordance with a third embodiment of the disclosure and subject matter hereof is depicted. In this embodiment, and analogously to the second embodiment, plunger retainer mechanism 36'' can be non-pivotably coupled to syringe pump housing 12 by mount 74, and force sensor 54 can be shiftable along a linear path 80.

In this third embodiment, plunger retainer mechanism 36'' includes a frame 52 supporting a movable element 76, driven by one or more pivotable syringe plunger thumb press captures 88. Moveable element 76 is operably coupled to frame 52 by a slideable connector, such as a track and clip assembly (not depicted), that enables moveable element 76 to traverse along a substantially linear path 80 relative to frame 52. Each thumb press capture 88 can rotate about pivot 50 relative to frame 52 and can include one or more arms 48 (not explicitly depicted in FIG. 7, but as depicted analogously in FIG. 3A). In an embodiment, arms 48 are configured to pivot to removably but securely engage plunger 28 and/or thumb press 38 of syringe 16 (not depicted in FIG. 7), thereby removably but securely coupling plunger 28 and/or thumb press 38 to plunger retainer mechanism 36''.

Movable element 76 can include one or more toothed racks 90 for interaction with a plurality of teeth 92 at least partially surrounding pivot 50 (again, not explicitly depicted in FIG. 7; but as depicted analogously in FIG. 3A), thereby causing each thumb press capture 88 to pivot relative to frame 52 as moveable element 76 traverses forwardly or backwardly along linear path 80. Force sensor 54 can be fixedly coupled to movable element 76, thereby enabling axial alignment of plunger 28 (not depicted in FIG. 7) of a range of syringe diameters or sizes, with force sensor 54 along linear path 80. As moveable element 76 traverses along linear path 80 to align the force sensor 54 with the plunger 28, each thumb press capture 88 pivots relative to frame, so as to securely engage plunger 28 and/or thumb press 38 by way of one or more arms 48 (again, not explicitly depicted in FIG. 7) as aforescribed.

In an embodiment, a push rod 94 enables control of the position of movable element 76 along linear path 80. In an embodiment, push rod 94 is controlled manually by a user. In other embodiments, push rod 94 is controlled by one or more drive mechanisms, such as a motor or actuator (not depicted). In other embodiments, push rod 94 is mechanically or electro-
5 mechanically linked to components (not depicted) in syringe pump 10 that move in response to varying sizes of syringes 16 installed in pump 10.

Persons of ordinary skill in the relevant arts will recognize that embodiments may comprise fewer features than illustrated in any individual embodiment described above. Embodiments described by example or otherwise contemplated herein are not meant to be an
10 exhaustive presentation of ways in which the various features may be combined, substituted, or arranged. Accordingly, the embodiments are not mutually exclusive combinations of features; rather, embodiments can comprise a combination of different individual features selected from different individual embodiments, as understood by persons of ordinary skill in the art. Moreover, elements described with respect to one embodiment can be implemented in other
15 embodiments even when not described in such embodiments unless otherwise noted. Although a dependent claim may refer in the claims to a specific combination with one or more other claims, other embodiments can also include a combination of the dependent claim with the subject matter of each other dependent claim or a combination of one or more features with other dependent or independent claims. Such combinations are proposed herein unless it is stated that
20 a specific combination is not intended. Furthermore, it is intended also to include features of a claim in any other independent claim even if this claim is not directly made dependent to the independent claim.

It is therefore also to be appreciated and understood that, irrespective of a particular embodiment, the novel and inventive subject matter hereof—as described by example or
25 otherwise contemplated herein—advantageously provides controlled movement of a force sensor of a syringe pump to maintain axial alignment of the force sensor with a component or components of a medicament reservoir (such as, for example, a thumb press of a syringe) installed in the pump. Such alignment of the force sensor with an axis or centerline of the reservoir can advantageously reduce, or even in some instances eliminate, an offset between the
30 axes of the force sensor and the reservoir. Thus, any discrepancy between an actual force applied by the pump on the reservoir and a value of a measured force experienced by the force sensor can be reduced or possibly eliminated. Furthermore, such controlled movement of the force sensor into axial alignment with medicament reservoirs of varying diameters can aid in minimizing start-up delays that otherwise would typically occur with known syringe pumps

where the force sensor is fixed in one location. Additional advantages of such a controllably moveable force sensor can include, for example: minimizing or eliminating a need for algorithmic compensation to account for force sensor discrepancies in a pump start-up routine, etc.; more reliable and direct force sensor operations and measurements; reduced bending moments that could otherwise be experienced by reservoir components due to off-axis driving forces from the pump; and minimizing or eliminating a desire to move the reservoir or syringe itself, installed in the pump, to be in better axial alignment with the force sensor.

Any incorporation by reference of documents above is limited such that no subject matter is incorporated that is contrary to the disclosure herein. Any incorporation by reference of documents above is further limited such that no claims included in the documents are incorporated by reference herein. Any incorporation by reference of documents above is yet further limited such that any definitions provided in the documents are not incorporated by reference herein unless expressly included herein.

For purposes of interpreting the claims, it is expressly intended that the provisions of Section 112, sixth paragraph of 35 U.S.C. are not to be invoked unless the specific terms “means for” or “step for” are recited in a claim.

CLAIMS

1. A syringe pump configured to mechanically align a force sensor with an axis of a plunger of a syringe for a purpose of minimizing force measurement inaccuracies, comprising:
 - 5 a syringe pump housing configured to receive at least a portion of the syringe, wherein the syringe is selected from a plurality of syringes of different dimensions;
 - a plunger retainer mechanism pivotably coupled to the syringe pump housing and configured to retain the plunger of the syringe, wherein the plunger retainer mechanism pivots relative to the syringe pump housing based on a sensed dimension of the plunger to align a force
 - 10 sensor coupled to the plunger retainer mechanism with the axis of the plunger; and
 - a syringe drive mechanism operably coupled to the syringe pump housing and configured to shift the plunger relative to the portion of the syringe received by the syringe pump housing.
2. The syringe pump of claim 1, wherein the plunger retainer mechanism includes at least
- 15 one arm configured to pivot so as to abut a portion of the syringe.
3. The syringe pump of claim 2, wherein the plunger retainer mechanism includes three arms.
- 20 4. The syringe pump of claim 2, wherein the plunger retainer mechanism includes a gear assembly configured to pivot the at least one arm into contact with the syringe.
5. The syringe pump of claim 4, wherein the gear assembly is driven by a drive mechanism.
- 25 6. The syringe pump of claim 5, wherein the drive mechanism is a motor.
7. The syringe pump of claim 6, wherein the motor is at least partially controlled by a keypad.
- 30 8. A syringe pump configured to mechanically align a force sensor with an axis of a plunger of a syringe for a purpose of minimizing force measurement inaccuracies, comprising:
 - a syringe pump housing configured to receive at least a portion of the syringe, wherein the syringe is selected from a plurality of syringes of different dimensions;

a plunger retainer mechanism coupled to the syringe pump housing and configured to retain the plunger of the syringe, wherein the force sensor is shiftably coupled to the plunger retainer mechanism enabling movement of the force sensor along a linear path relative to the plunger retainer mechanism to align the force sensor with the axis of the plunger; and

5 a syringe drive mechanism operably coupled to the syringe pump housing and configured to shift the plunger relative to the portion of the syringe received by the syringe pump housing.

9. The syringe pump of claim 8, wherein the force sensor is mounted to a toothed rack.

10 10. The syringe pump of claim 9, wherein the toothed rack is driven by a drive mechanism.

11. The syringe pump of claim 10, wherein the drive mechanism is a pushrod.

12. The syringe pump of claim 10, wherein the drive mechanism is a motor.

15

13. The syringe pump of claim 12, wherein the motor is at least partially controlled by a keypad.

14. The syringe pump of claim 8, wherein the plunger retainer mechanism includes at least
20 one arm configured to pivot so as to abut a portion of the syringe.

15. The syringe pump of claim 14, wherein the plunger retainer mechanism includes a gear assembly configured to pivot the at least one arm into contact with the syringe.

25

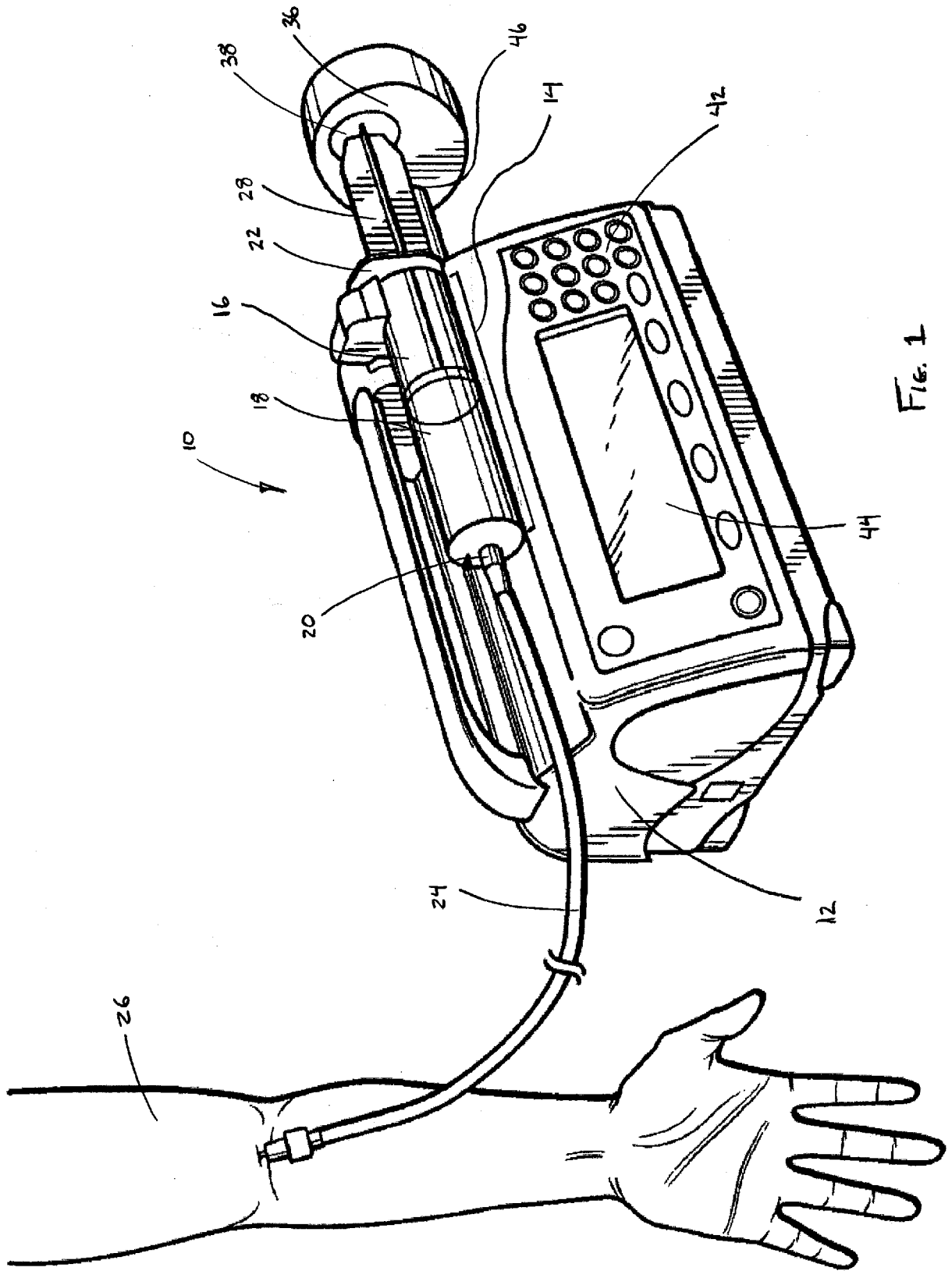

Fig. 1

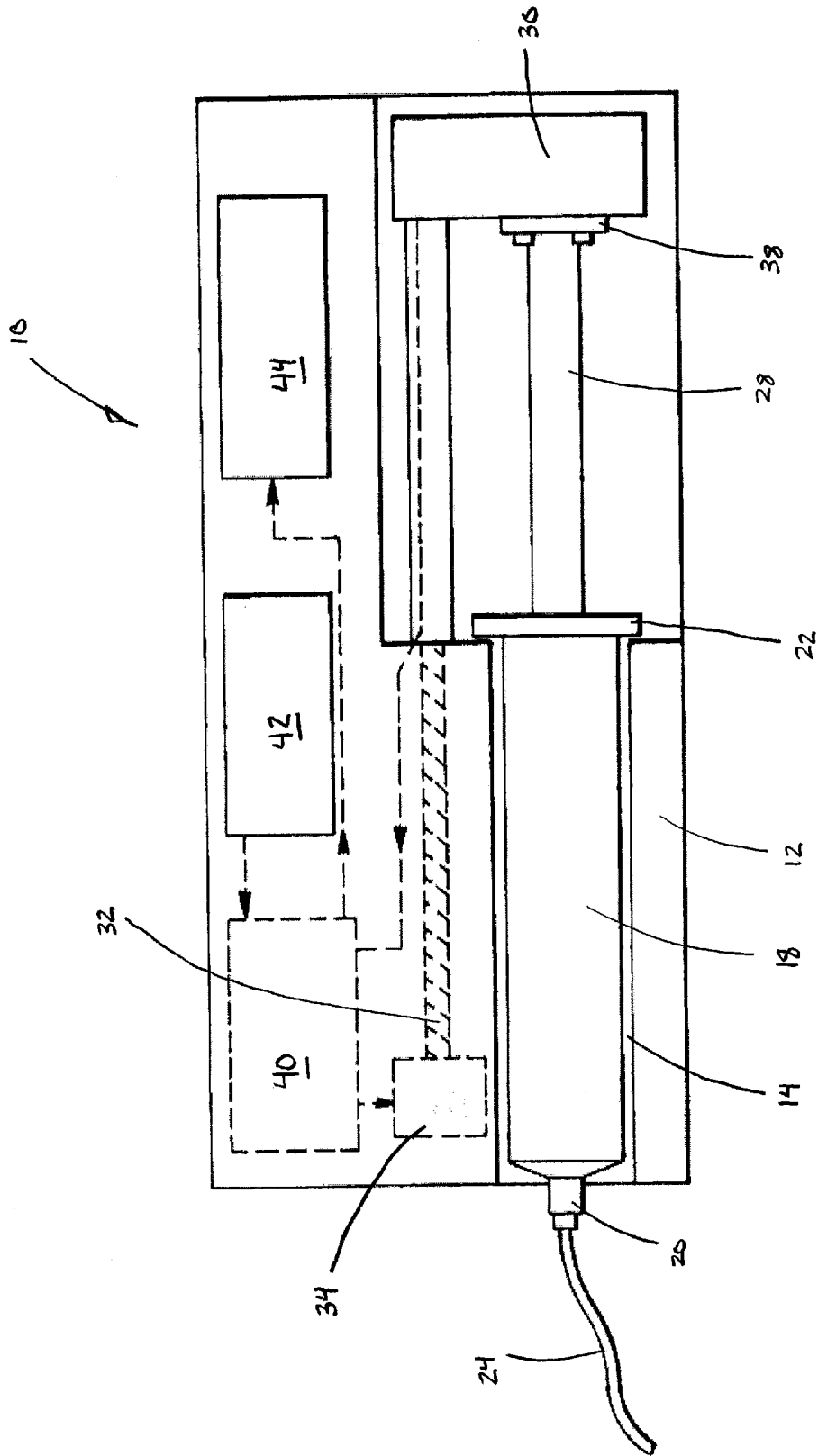

FIG. 2

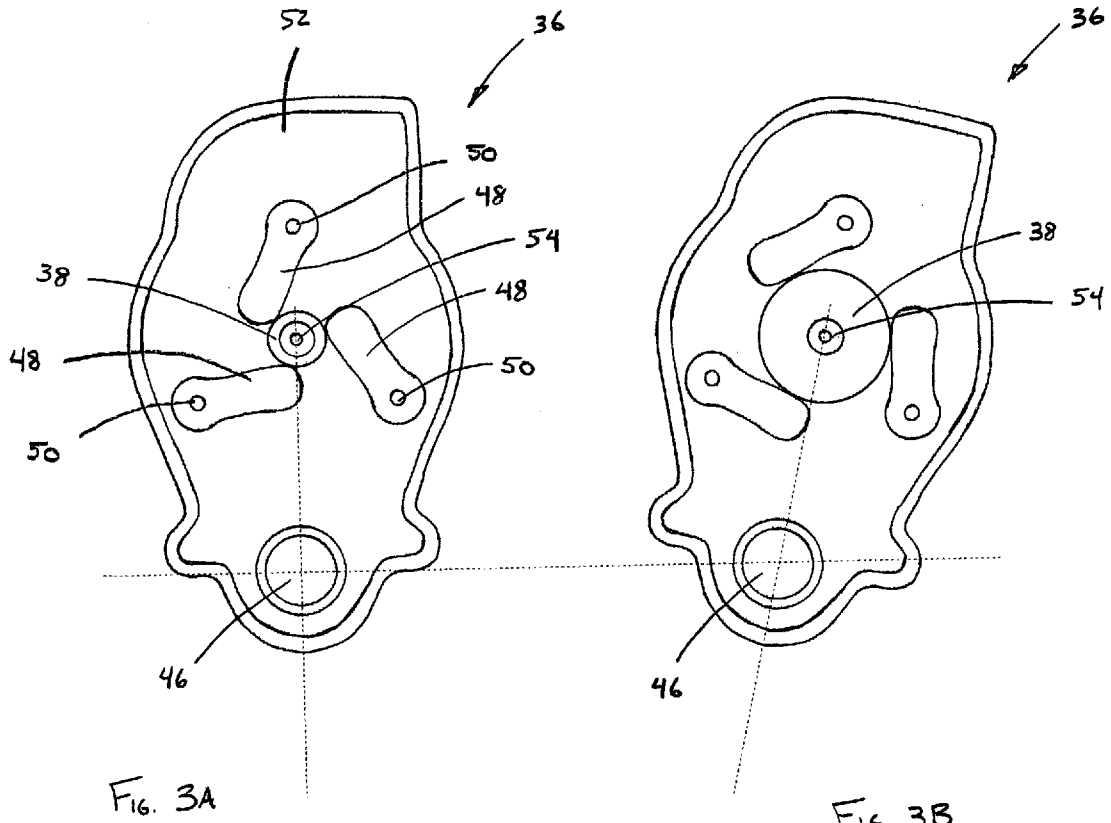

FIG. 3A

FIG. 3B

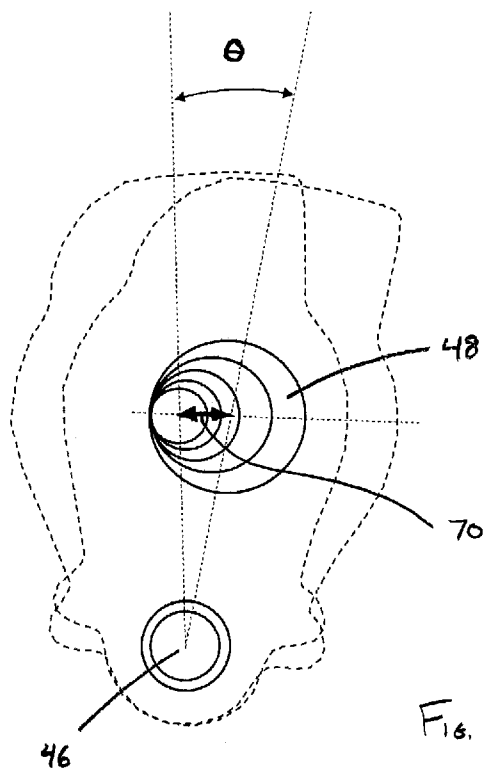

FIG. 4

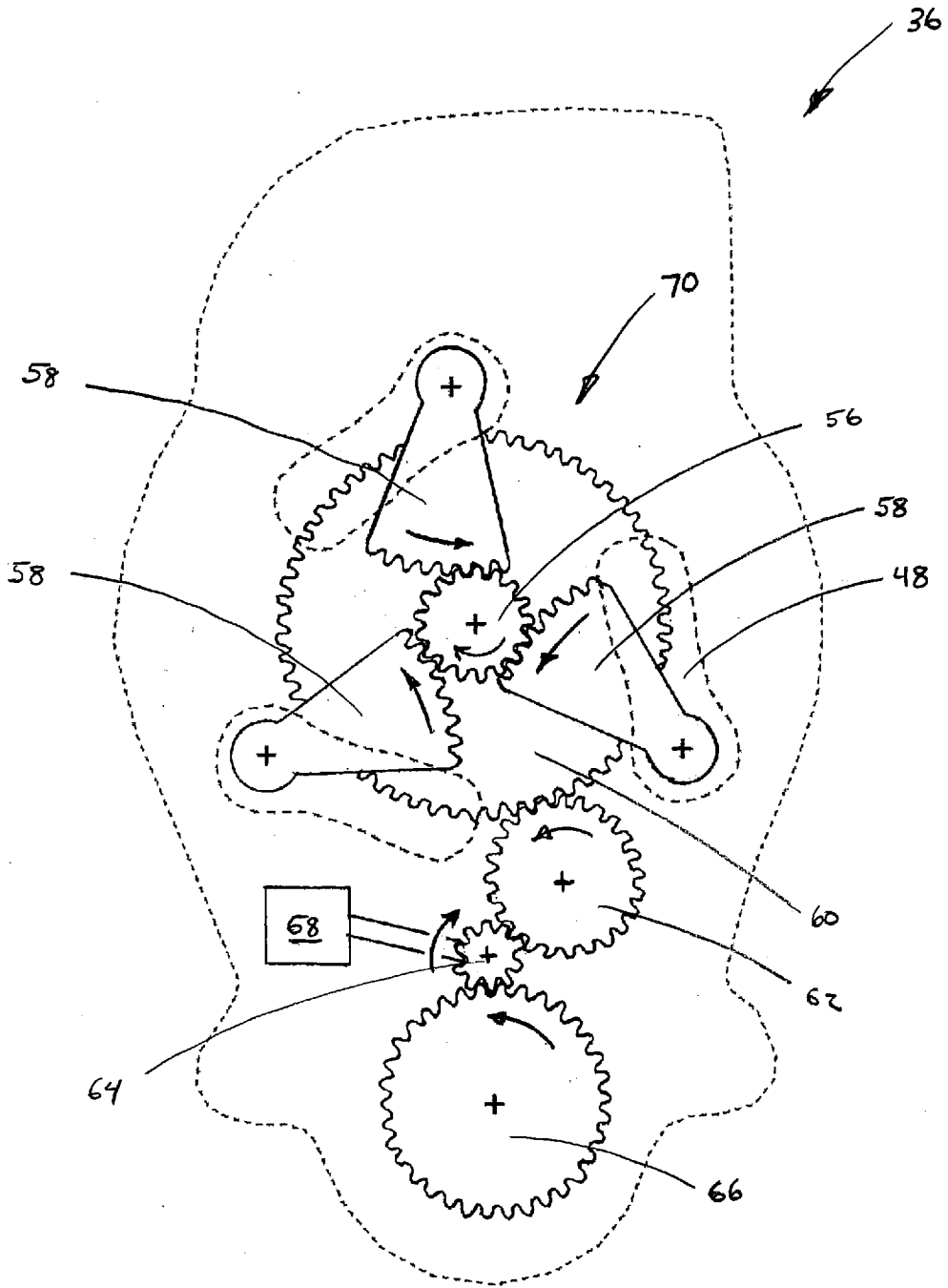

FIG. 5

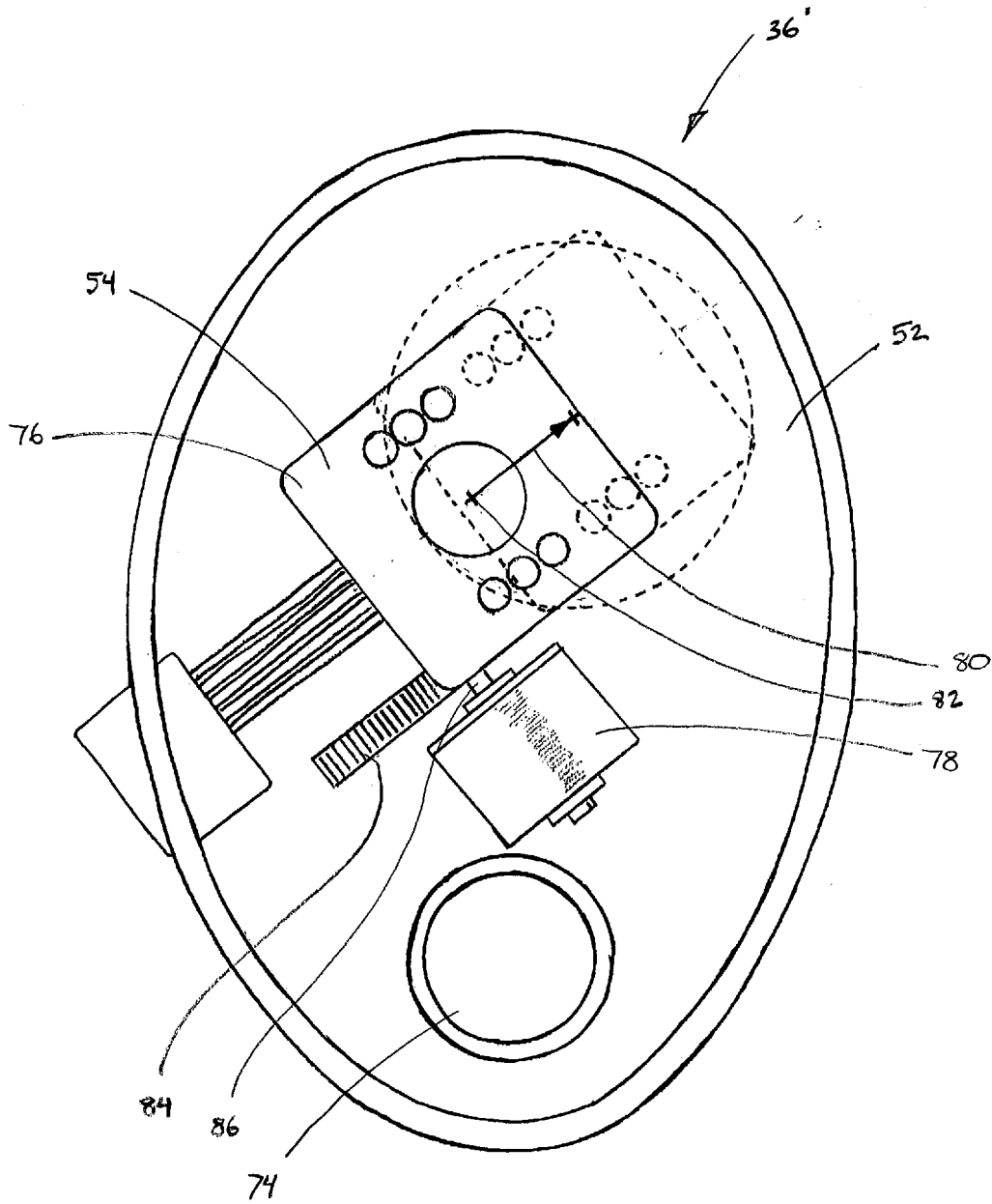

FIG. 6

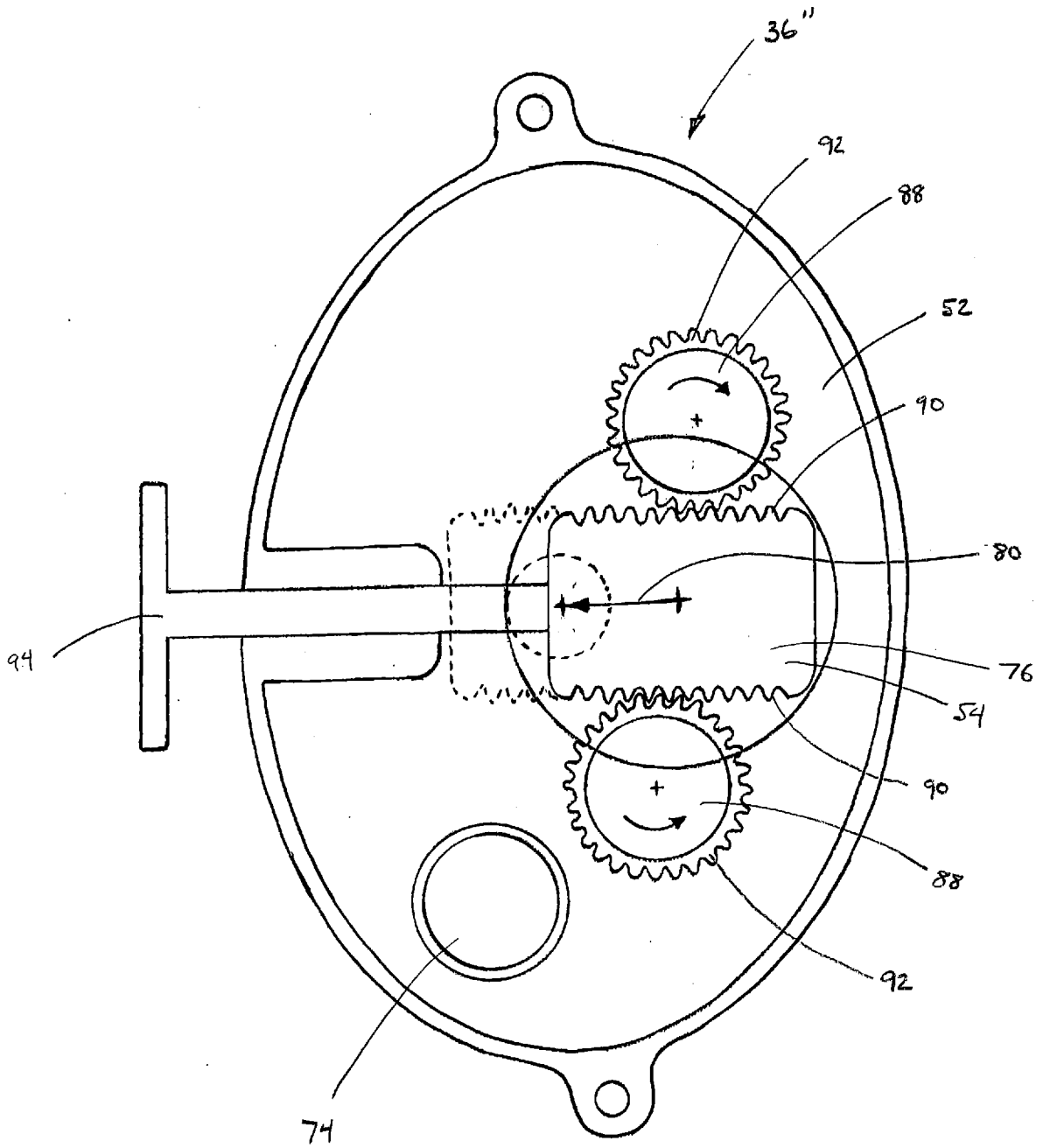

FIG. 7

A. CLASSIFICATION OF SUBJECT MATTER**A61M 5/145(2006.01)I**

According to International Patent Classification (IPC) or to both national classification and IPC

B. FIELDS SEARCHEDMinimum documentation searched (classification system followed by classification symbols)
A61M 5/145; A61M 5/142; A61J 7/00; A61B 5/02; A61M 1/10; F04B 9/02; A61M 1/00Documentation searched other than minimum documentation to the extent that such documents are included in the fields searched
Korean utility models and applications for utility models
Japanese utility models and applications for utility modelsElectronic data base consulted during the international search (name of data base and, where practicable, search terms used)
eKOMPASS(KIPO internal) & keywords: syringe pump, force sensor, align, shift**C. DOCUMENTS CONSIDERED TO BE RELEVANT**

Category*	Citation of document, with indication, where appropriate, of the relevant passages	Relevant to claim No.
A	WO 2013-177379 A1 (SMITHS MEDICAL ASD, INC.) 28 November 2013 See claim 3; figures 1-3A.	1-15
A	WO 2014-100658 A1 (DEKA PRODUCTS LIMITED PARTNERSHIP) 26 June 2014 See entire document.	1-15
A	US 2013-0129532 A1 (NUMIA MEDICAL TECHNOLOGY, LLC.) 23 May 2013 See entire document.	1-15
A	WO 2012-040528 A1 (PERQFLO, LLC et al.) 29 March 2012 See entire document.	1-15
A	US 8262616 B2 (GRANT, K. L. et al.) 11 September 2012 See entire document.	1-15

 Further documents are listed in the continuation of Box C. See patent family annex.

* Special categories of cited documents:

"A" document defining the general state of the art which is not considered to be of particular relevance

"E" earlier application or patent but published on or after the international filing date

"L" document which may throw doubts on priority claim(s) or which is cited to establish the publication date of another citation or other special reason (as specified)

"O" document referring to an oral disclosure, use, exhibition or other means

"P" document published prior to the international filing date but later than the priority date claimed

"T" later document published after the international filing date or priority date and not in conflict with the application but cited to understand the principle or theory underlying the invention

"X" document of particular relevance; the claimed invention cannot be considered novel or cannot be considered to involve an inventive step when the document is taken alone

"Y" document of particular relevance; the claimed invention cannot be considered to involve an inventive step when the document is combined with one or more other such documents, such combination being obvious to a person skilled in the art

"&" document member of the same patent family

Date of the actual completion of the international search

12 September 2016 (12.09.2016)

Date of mailing of the international search report

12 September 2016 (12.09.2016)

Name and mailing address of the ISA/KR

International Application Division
Korean Intellectual Property Office
189 Cheongsa-ro, Seo-gu, Daejeon, 35208, Republic of Korea

Facsimile No. +82-42-481-8578

Authorized officer

CHO, KI YUN

Telephone No. +82-42-481-5655



INTERNATIONAL SEARCH REPORT

Information on patent family members

International application No.

PCT/US2016/037967

Patent document cited in search report	Publication date	Patent family member(s)	Publication date
WO 2013-177379 A1	28/11/2013	CA 2872955 A1	28/11/2013
		EP 2854625 A1	08/04/2015
		JP 2015-517391 A	22/06/2015
		KR 10-2015-0011841 A	02/02/2015
		US 2015-0133890 A1	14/05/2015
WO 2014-100658 A1	26/06/2014	AU 2012-358397 A1	27/06/2013
		AU 2013-266256 A1	28/11/2013
		AU 2013-266864 A1	28/11/2013
		AU 2013-361072 A1	26/06/2014
		AU 2013-361072 A1	16/07/2015
		AU 2013-361156 A1	26/06/2014
		AU 2013-364039 A1	26/06/2014
		AU 2013-364047 A1	26/06/2014
		CA 2837187 A1	29/11/2012
		CA 2859828 A1	27/06/2013
		CA 2860156 A1	27/06/2013
		CA 2860224 A1	27/06/2013
		CA 2874276 A1	28/11/2013
		CA 2874329 A1	28/11/2013
		CA 2895766 A1	26/06/2014
		CA 2896063 A1	26/06/2014
		CA 2896068 A1	26/06/2014
		CA 2896086 A1	26/06/2014
		CA 2896088 A1	26/06/2014
		CA 2896090 A1	26/06/2014
		EP 2714123 A2	09/04/2014
		EP 2793796 A2	29/10/2014
		EP 2793975 A2	29/10/2014
		EP 2793976 A2	29/10/2014
		EP 2793977 A2	29/10/2014
		EP 2793977 B1	18/11/2015
		EP 2795492 A1	29/10/2014
		EP 2839398 A1	25/02/2015
		EP 2841132 A2	04/03/2015
		EP 2934423 A2	28/10/2015
		EP 2934617 A1	28/10/2015
		EP 2936360 A2	28/10/2015
		EP 2936361 A2	28/10/2015
EP 2936362 A2	28/10/2015		
EP 2936363 A2	28/10/2015		
JP 2014-529409 A	13/11/2014		
JP 2015-505258 A	19/02/2015		
JP 2015-505259 A	19/02/2015		
JP 2015-508526 A	19/03/2015		
JP 2015-510407 A	09/04/2015		
JP 2015-520652 A	23/07/2015		
JP 2015-531092 A	29/10/2015		
JP 2016-504112 A	12/02/2016		

INTERNATIONAL SEARCH REPORT

Information on patent family members

International application No.

PCT/US2016/037967

Patent document cited in search report	Publication date	Patent family member(s)	Publication date
		JP 2016-504876 A	12/02/2016
		JP 2016-508045 A	17/03/2016
		KR 10-2014-0106705 A	03/09/2014
		US 2012-0185267 A1	19/07/2012
		US 2013-0037485 A1	14/02/2013
		US 2013-0177455 A1	11/07/2013
		US 2013-0182381 A1	18/07/2013
		US 2013-0184676 A1	18/07/2013
		US 2013-0188040 A1	25/07/2013
		US 2013-0191513 A1	25/07/2013
		US 2013-0197693 A1	01/08/2013
		US 2013-0204188 A1	08/08/2013
		US 2013-0272773 A1	17/10/2013
		US 2013-0281965 A1	24/10/2013
		US 2013-0297330 A1	07/11/2013
		US 2013-0317753 A1	28/11/2013
		US 2013-0317837 A1	28/11/2013
		US 2013-0346108 A1	26/12/2013
		US 2014-0188076 A1	03/07/2014
		US 2014-0188516 A1	03/07/2014
		US 2014-0195639 A1	10/07/2014
		US 9151646 B2	06/10/2015
		US 9295778 B2	29/03/2016
		US 9400873 B2	26/07/2016
		WO 2012-161744 A2	29/11/2012
		WO 2013-095459 A1	27/06/2013
		WO 2013-096713 A2	27/06/2013
		WO 2013-096718 A2	27/06/2013
		WO 2013-096722 A2	27/06/2013
		WO 2013-096909 A2	27/06/2013
		WO 2013-176770 A2	28/11/2013
		WO 2013-177357 A1	28/11/2013
		WO 2014-100557 A2	26/06/2014
		WO 2014-100571 A2	26/06/2014
		WO 2014-100687 A2	26/06/2014
		WO 2014-100736 A2	26/06/2014
		WO 2014-100744 A2	26/06/2014
US 2013-0129532 A1	23/05/2013	AU 2008-262348 A1	18/12/2008
		CA 2690551 A1	18/12/2008
		EP 2207580 A1	21/07/2010
		US 2009-0005736 A1	01/01/2009
		US 8911403 B2	16/12/2014
		WO 2008-153985 A1	18/12/2008
WO 2012-040528 A1	29/03/2012	AU 2011-305316 A1	11/04/2013
		AU 2011-305316 B2	15/01/2015
		CA 2812458 A1	29/03/2012
		EP 2618867 A1	31/07/2013
		JP 2013-537844 A	07/10/2013

INTERNATIONAL SEARCH REPORT

Information on patent family members

International application No.

PCT/US2016/037967

Patent document cited in search report	Publication date	Patent family member(s)	Publication date
		KR 10-2013-0138358 A	18/12/2013
		RU 2013118718 A	27/10/2014
		US 2012-0078170 A1	29/03/2012
		US 2012-0078181 A1	29/03/2012
		US 2012-0078182 A1	29/03/2012
		US 2012-0078183 A1	29/03/2012
		US 2012-0078184 A1	29/03/2012
		US 2012-0078185 A1	29/03/2012
		US 2012-0078216 A1	29/03/2012
		US 2012-0078217 A1	29/03/2012
		US 2012-0078222 A1	29/03/2012
		US 8430849 B2	30/04/2013
		US 8777901 B2	15/07/2014
		US 8915879 B2	23/12/2014
		US 9216249 B2	22/12/2015
		US 9308320 B2	12/04/2016
		US 9320849 B2	26/04/2016
		US 9381300 B2	05/07/2016
US 8262616 B2	11/09/2012	CA 2739968 A1	15/04/2010
		EP 2370126 A2	05/10/2011
		US 2009-0099523 A1	16/04/2009
		US 2010-0089475 A1	15/04/2010
		US 2010-0090843 A1	15/04/2010
		US 2010-0094215 A1	15/04/2010
		US 2010-0094220 A1	15/04/2010
		US 2010-0094221 A1	15/04/2010
		US 2010-0094222 A1	15/04/2010
		US 2010-0094261 A1	15/04/2010
		US 2011-0208123 A1	25/08/2011
		US 2013-0066265 A1	14/03/2013
		US 2015-0005711 A1	01/01/2015
		US 8016789 B2	13/09/2011
		US 8034026 B2	11/10/2011
		US 8066672 B2	29/11/2011
		US 8223028 B2	17/07/2012
		US 8267892 B2	18/09/2012
		US 8708376 B2	29/04/2014
		US 8834429 B2	16/09/2014
		US 9180245 B2	10/11/2015
		WO 2010-042814 A2	15/04/2010