



- (51) International Patent Classification:  
H03K 17/94 (2006.01) H03K 17/06 (2006.01)
- (21) International Application Number:  
PCT/US2015/057869
- (22) International Filing Date:  
28 October 2015 (28.10.2015)
- (25) Filing Language:  
English
- (26) Publication Language:  
English
- (30) Priority Data:  
62/074,902 4 November 2014 (04.11.2014) US  
14/698,690 28 April 2015 (28.04.2015) US  
14/855,031 15 September 2015 (15.09.2015) US

- (72) Inventors; and
- (71) Applicants : **WOOTTON, Matthew** [US/US]; 998 Emge Road, O'Fallon, MO 63366 (US). **WOOTTON, John** [US/US]; 6 Forsythia Lane, St. Louis, MO 63132 (US). **NISSMAN, Chris** [US/US]; 2371 N. Emerald Lake Ct., Tucson, AZ 85749 (US). **MCKINNEY, Justin** [US/US]; 636 Strecker Road, Wildwood, MO 63011 (US).
- (74) Agents: **DAMMAN, Kirk A.** et al.; Lewis Rice LLC, 600 Washington Avenue, Suite 2500, Box IP Department, St. Louis, MO 63101 (US).
- (81) Designated States (unless otherwise indicated, for every kind of national protection available): AE, AG, AL, AM, AO, AT, AU, AZ, BA, BB, BG, BH, BN, BR, BW, BY, BZ, CA, CH, CL, CN, CO, CR, CU, CZ, DE, DK, DM, DO, DZ, EC, EE, EG, ES, FI, GB, GD, GE, GH, GM, GT, HN, HR, HU, ID, IL, IN, IR, IS, JP, KE, KG, KN, KP, KR, KZ, LA, LC, LK, LR, LS, LU, LY, MA, MD, ME, MG, MK, MN, MW, MX, MY, MZ, NA, NG, NI, NO, NZ, OM, PA, PE, PG, PH, PL, PT, QA, RO, RS, RU, RW, SA, SC, SD, SE, SG, SK, SL, SM, ST, SV, SY, TH, TJ, TM, TN, TR, TT, TZ, UA, UG, US, UZ, VC, VN, ZA, ZM, ZW.

[Continued on next page]

(54) Title: INTELLIGENT ELECTRICAL SWITCH

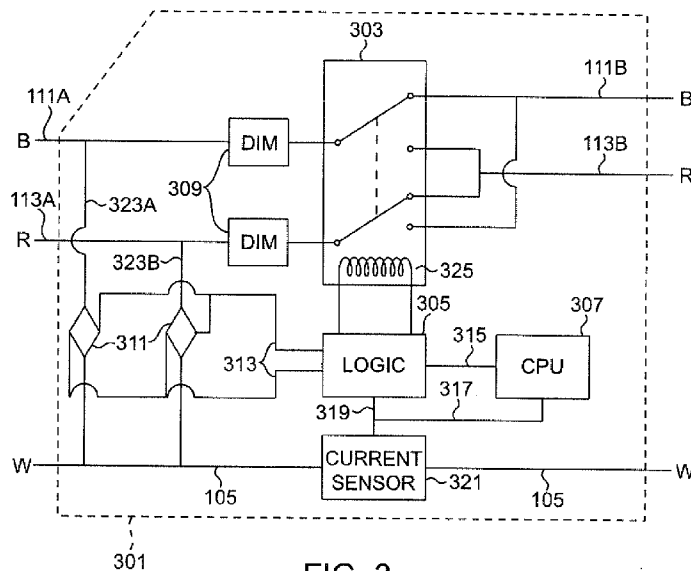
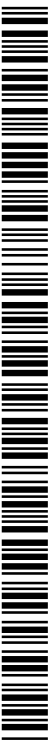

FIG. 3

[Continued on next page]



**(84) Designated States** (*unless otherwise indicated, for every kind of regional protection available*): ARIPO (BW, GH, GM, KE, LR, LS, MW, MZ, NA, RW, SD, SL, ST, SZ, TZ, UG, ZM, ZW), Eurasian (AM, AZ, BY, KG, KZ, RU, TJ, TM), European (AL, AT, BE, BG, CH, CY, CZ, DE, DK, EE, ES, FI, FR, GB, GR, HR, HU, IE, IS, IT, LT, LU, LV, MC, MK, MT, NL, NO, PL, PT, RO, RS, SE,

SI, SK, SM, TR), OAPI (BF, BJ, CF, CG, CI, CM, GA, GN, GQ, GW, KM, ML, MR, NE, SN, TD, TG).

**Published:**

— *with international search report (Art. 21(3))*

---

**(57) Abstract:** An intelligent electrical switch comprising a conventional mechanical switch connected to a computer system in communication with an external device and receiving instructions therefrom. The switch may be installed in an existing circuit to replace one switch in a multi-way wiring geometry, and includes a sensor detecting current on the neutral line. By determining the circuit state, the switch can determine whether, when instructions are received wirelessly to power the circuit on or off, the mechanical switch element should be toggled.

**INTELLIGENT ELECTRICAL SWITCH****CROSS REFERENCE TO RELATED APPLICATIONS**

[001] This application is a Continuation-in-Part of United States Utility Application No. 14/698,690, filed April 28, 2015, which in turn claims benefit of United States Provisional Application No. 62/074,902, filed November 4, 2014. This application also claims benefit of United States Provisional Application No. 62/074,902, filed November 4, 2014. The entirety of both of these applications is incorporated herein by reference.

**BACKGROUND****1. Field of the Invention**

[002] This disclosure is related to the field of electrical wiring, and more particularly to systems, methods, and apparatus pertaining to an intelligent multi-way electric switch.

[003] Electrical systems commonly include manual switching systems comprising a switch element combined into a three-way or four-way wiring geometry to provide users with the ability to operate a circuit from multiple locations. For example, it is desirable, and often required by building code, to have a light switch at each entrance to a room. However, if the switches are wired in serial, every switch must be “on” for the light to work. Likewise, if the switches are wired in parallel, every switch must be “off” for the light to turn off. Instead, multi-way wiring geometries are used to cause each switch to operate as a toggle. The circuit has two states – “on” (powered) and “off” (unpowered) – and operating any one of the switches causes the circuit to change to the opposite state – unpowered circuits receive power and turn on, and powered circuits turn off.

[004] In a typical and simple “on/off” switch operating a single circuit, the power supply coming into the building flows to the device which will ultimately receive electrical power. This device may be a light fixture, a wall receptacle, or any other device (or set of devices). The device or devices consuming power are known as the “load.” For electricity to flow,

there must be a complete electrical circuit between the electrical power source and the load. This means that the “wire” from the source to the load is actually at least two wires – a powered or “hot” wire that contains electrical current flowing to the load (conventionally known in the art as the “black” wire due to the typical color of the non-conductive sheathing surrounding it), and a “neutral” wire that allows current to flow back to the source (conventionally, the “white” wire), completing the circuit. Thus, a simple on/off switch is essentially a movable section of the circuit that causes the circuit to be complete or broken when a user flips the external switch component. That is, when the switch is in the “on” position, the circuit is complete and the electrical potential causes electrical current to flow to the load, providing it with power (and thus, if the load is a light, causing the light to turn on). When the switch moved to the “off” position, the circuit is broken, electrons stop flowing, and the load receives no substantial current, causing the light to turn off.

[005] A three-way switch operates on the same fundamental principles, except that an additional wire is required so that the function of turning power on/off works, regardless of which of the two switches is operated, and regardless of the state of the other switch. This is essentially done by wiring the two switches together with an additional wire so that any time one of the switches changes state, the circuit also changes state.

[006] This can be seen in prior art FIGs. 1A-1D. In FIG. 1A, the circuit (101) includes a hot wire (103) and a neutral wire (105) connected to the load (107) in circuit. In this case the load (107) is a light (107). The hot wire (103) enters a first three-way switch (109A). A section (111) of the hot wire runs from the first switch (109A) to a second three-way switch (109B), and then continues on to the load (107). Also wired between the switches (109A) and (109B) is a switch line (113), conventionally a “red” line due to the typical color of the sheathing. This switch line (113) is what allows the three-way geometry to work.

[007] In FIG. 1A, the light (107) is off and circuit (101) is broken, because there is no path for electric current to flow to the load (107). The power flows through the first switch (109A) and across the switch line (113) to the second switch (109B), but the second switch (109B) is connected to the hot line (103) section (111), leaving no continuous path to the load (107). If either switch (109A) and (109B) is toggled, however, power will flow. As can be seen in FIG. 1B, if the first switch (109A) is toggled, a complete circuit results, as electrons can flow from the hot line (103) to switch one (109A), across section (111) to switch two (109B), and into the load (107). Alternatively, as shown in FIG. 1C, if the second switch (109B) is toggled, power can flow from hot line (103) to switch one (109A), across the switch wire (113) to switch two (109B), and then into the load (107). Similarly, either circuit (101) can be broken by operating either switch (109A) and (109B), causing the light (107) to turn off.

[008] This system requires specialized hardware. This is because the hot (103) and neutral (105) wires are generally bundled within an outer sheathe when run through the walls of a building, and then the sheathe is cut and the individual wires are separated and individually attached to the switch, typically by wrapping the end of each wire around a different metal post or pole on the switch, and tightening a screw that holds the wire to the post. The posts are in turn connected to the internal switch components. For this to work, the switch must have enough posts, in the proper configuration, to support three-way switching. This also means that, at a minimum, the section of bundled wire running between the two switches must have a hot (black) line, a neutral (white) line, and a switch (red) line.

[009] Similar techniques and hardware have been developed for four-way switching. For example, in the depicted prior art embodiment of FIGs. 2A and 2B, four-way switching is implemented using a pair of three-way switches (109A) and (109B) wired to a four-way switch (115). As with three-way switching, the first three-way switch (109A) is connected to

the four-way switch (115) using a section (111A) of the hot wire along with a section (113A) of switch wire. Likewise, the four-way switch (115) is connected to a second three-way switch (109B) using a second section of hot wire (111B) and a second section of switch wire (113B). The four-way switch (115) is a double throw/double pull switch, meaning that when the switch is operated, electrical flow through the switch is reversed between the poles. This essentially means that if an electrical path already exists in the system, operating a four-way switch will break the circuit. If electrical flow does not exist, operating a four-way switch will close the circuit. The three-way switches operate as described with respect to prior art FIGs. 1A-1D.

[010] Various attempts have been made to implement a smart multi-way switch via home automation technologies. For example, the load may be a smart device with a single internal switch that communicates wirelessly with remotely placed switches. Thus, when any switch is operated, the device can detect its own state and toggle on/off as needed. However, these systems do not operate in conjunction with existing wiring and hardware.

[011] For example, home automation systems usually require that fixtures and/or switches be replaced with “smart” devices requiring extensive configuration and set-up. This can add expense, hassle, and waste, as the existing equipment is lost. This can be a problem in buildings with antique or non-standard fixtures, where replacement smart fixtures may not be available. Further, if the conventional wiring is replaced by smart systems, system operation is dependent on continuous communication. If communication is disrupted, the system no longer operates. This makes such systems susceptible to catastrophic failure in the very circumstances where the fixture is likely to be needed. For example, during a storm, a single nearby lightning strike could render the components inoperable. Without a conventional wiring system as a fail-safe, these systems are unsuitable for use in many applications. Thus, users who wish to add automation features to a residence or other building are forced to

replace major components of the system and lose the security and/or reliability of conventional switching technologies.

## SUMMARY

[012] The following is a summary of the invention in order to provide a basic understanding of some aspects of the invention. This summary is not intended to identify key or critical elements of the invention or to delineate the scope of the invention. The sole purpose of this section is to present some concepts of the invention in a simplified form as a prelude to the more detailed description that is presented later.

[013] Because of these and other problems in the art, described herein, among other things, is an intelligent switching apparatus (301) which actuates a conventional mechanical switch (303) to cause a change in system state. Such a device does not merely mimic the behavior of a conventional system, but actually uses such a system, meaning that if the intelligent switching apparatus were inoperable for any reason, manual use of the switch would continue to function to cause a change in the system state (e.g., power a circuit on or off). Such a system has further advantages in that only one switch is replaced with the intelligent switch to allow the entire multi-way circuit to be toggled remotely. Further, such a smart switch can intelligently track system state knowledge and make decisions accordingly, rather than serving merely as a toggle.

BRIEF DESCRIPTION OF THE DRAWINGS

[014] FIGs. 1A-1D depict a prior art three-way power switch.

[015] FIGs. 2A-2B depict a prior art four-way power switch.

[016] FIG. 3 depicts a schematic diagram of an intelligent switch system according to the present disclosure.

[017] FIG. 4 depicts a schematic diagram of a networking implementation according to the present disclosure.

## DESCRIPTION OF THE PREFERRED EMBODIMENT(S)

[018] The following detailed description and disclosure illustrates by way of example and not by way of limitation. This description will clearly enable one skilled in the art to make and use the disclosed systems and methods, and describes several embodiments, adaptations, variations, alternatives and uses of the disclosed systems and methods. As various changes could be made in the above constructions without departing from the scope of the disclosures, it is intended that all matter contained in the description or shown in the accompanying drawings shall be interpreted as illustrative and not in a limiting sense.

[019] Throughout this disclosure, the term “computer” describes hardware which generally implements functionality provided by digital computing technology, particularly computing functionality associated with microprocessors. The term “computer” is not intended to be limited to any specific type of computing device, but it is intended to be inclusive of all computational devices including, but not limited to: processing devices, microprocessors, personal computers, desktop computers, laptop computers, workstations, terminals, servers, clients, portable computers, handheld computers, smart phones, tablet computers, mobile devices, server farms, hardware appliances, minicomputers, mainframe computers, video game consoles, handheld video game products, and wearable computing devices including but not limited to eyewear, wristwear, pendants, and clip-on devices.

[020] As used herein, a “computer” is necessarily an abstraction of the functionality provided by a single computer device outfitted with the hardware and accessories typical of computers in a particular role. By way of example and not limitation, the term “computer” in reference to a laptop computer would be understood by one of ordinary skill in the art to include the functionality provided by pointer-based input devices, such as a mouse or track pad, whereas the term “computer” used in reference to an enterprise-class server would be

understood by one of ordinary skill in the art to include the functionality provided by redundant systems, such as RAID drives and dual power supplies.

[021] It is also well known to those of ordinary skill in the art that the functionality of a single computer may be distributed across a number of individual machines. This distribution may be functional, as where specific machines perform specific tasks; or, balanced, as where each machine is capable of performing most or all functions of any other machine and is assigned tasks based on its available resources at a point in time. Thus, the term “computer” as used herein, can refer to a single, standalone, self-contained device or to a plurality of machines working together or independently, including without limitation: a network server farm, “cloud” computing system, software-as-a-service, or other distributed or collaborative computer networks.

[022] Those of ordinary skill in the art also appreciate that some devices which are not conventionally thought of as “computers” nevertheless exhibit the characteristics of a “computer” in certain contexts. Where such a device is performing the functions of a “computer” as described herein, the term “computer” includes such devices to that extent. Devices of this type include but are not limited to: network hardware, print servers, file servers, NAS and SAN, load balancers, and any other hardware capable of interacting with the systems and methods described herein in the matter of a conventional “computer.”

[023] Throughout this disclosure, the term “software” refers to code objects, program logic, command structures, data structures and definitions, source code, executable and/or binary files, machine code, object code, compiled libraries, implementations, algorithms, libraries, or any instruction or set of instructions capable of being executed by a computer processor, or capable of being converted into a form capable of being executed by a computer processor, including without limitation virtual processors, or by the use of run-time environments, virtual machines, and/or interpreters. Those of ordinary skill in the art recognize that software

can be wired or embedded into hardware, including without limitation onto a microchip, and still be considered “software” within the meaning of this disclosure. For purposes of this disclosure, software includes without limitation: instructions stored or storable in RAM, ROM, flash memory BIOS, CMOS, mother and daughter board circuitry, hardware controllers, USB controllers or hosts, peripheral devices and controllers, video cards, audio controllers, network cards, Bluetooth® and other wireless communication devices, virtual memory, storage devices and associated controllers, firmware, and device drivers. The systems and methods described here are contemplated to use computers and computer software typically stored in a computer- or machine-readable storage medium or memory.

[024] Throughout this disclosure, terms used herein to describe or reference media holding software, including without limitation terms such as “media,” “storage media,” and “memory,” may include or exclude transitory media such as signals and carrier waves.

[025] Throughout this disclosure, the terms “web,” “web site,” “web server,” “web client,” and “web browser” refer generally to computers programmed to communicate over a network using the HyperText Transfer Protocol (“HTTP”), and/or similar and/or related protocols including but not limited to HTTP Secure (“HTTPS”) and Secure Hypertext Transfer Protocol (“SHTTP”). A “web server” is a computer receiving and responding to HTTP requests, and a “web client” is a computer having a user agent sending and receiving responses to HTTP requests. The user agent is generally web browser software.

[026] Throughout this disclosure, the term “network” generally refers to a voice, data, or other telecommunications network over which computers communicate with each other. The term “server” generally refers to a computer providing a service over a network, and a “client” generally refers to a computer accessing or using a service provided by a server over a network. Those having ordinary skill in the art will appreciate that the terms “server” and “client” may refer to hardware, software, and/or a combination of hardware and software,

depending on context. Those having ordinary skill in the art will further appreciate that the terms “server” and “client” may refer to endpoints of a network communication or network connection, including but not necessarily limited to a network socket connection. Those having ordinary skill in the art will further appreciate that a “server” may comprise a plurality of software and/or hardware servers delivering a service or set of services. Those having ordinary skill in the art will further appreciate that the term “host” may, in noun form, refer to an endpoint of a network communication or network (*e.g.*, “a remote host”), or may, in verb form, refer to a server providing a service over a network (“hosts a website”), or an access point for a service over a network.

[027] Throughout this disclosure, the term “real time” refers to software operating within operational deadlines for a given event to commence or complete, or for a given module, software, or system to respond, and generally invokes that the response or performance time is, in ordinary user perception and considered the technological context, effectively generally contemporaneous with a reference event. Those of ordinary skill in the art understand that “real time” does not literally mean the system processes input and/or responds instantaneously, but rather that the system processes and/or responds rapidly enough that the processing or response time is within the general human perception of the passage of real time in the operational context of the program. Those of ordinary skill in the art understand that, where the operational context is a graphical user interface, “real time” normally implies a response time of no more than one second of actual time, with milliseconds or microseconds being preferable. However, those of ordinary skill in the art also understand that, under other operational contexts, a system operating in “real time” may exhibit delays longer than one second, particularly where network operations are involved.

[028] Throughout this disclosure, the term “embedded system,” “embedded computer,” and variants thereof distinguish special purpose computer hardware and software from general-

purpose computer hardware and software. As used herein, an embedded system is a special-purpose system in which the computer is mostly or completely encapsulated by the device it controls. Unlike a general-purpose computer, such as a personal computer, an embedded system generally performs more limited, pre-defined tasks, usually with very specific requirements to accomplish a limited and pre-defined set of operational tasks. Since the system is dedicated to a specific task, it is more easily optimized for the task, reducing size and cost by eliminating unnecessary components found in general-purpose computers, and designing board circuitry and system geometry to improve operational efficiency, reduce manufacturing cost, and address operation-specific conditions, such as temperature extremes.

[029] In the depicted embodiment of FIG. 3, an intelligent switch system (301) or device (301) according to the present disclosure is depicted. The depicted device (301) is installed in a four-way switch circuit. The device (301) replaces the four-way switch (115) component of the prior art system, such as that depicted in FIG. 2. The depicted device (302) comprises a conventional four-way switch (303), along with other components not found in a conventional switch, including a logic unit (305), a computer system (307), a current sensor (321) and, optionally, a dimmer circuit (309). Additional circuitry, also depicted in FIG. 3, is included to connect these components as described herein.

[030] In the depicted embodiment, incoming hot lines (111A) and (113A) supply power to the device (301) and are connected to a first three-way switch (109A) situated between the power source and the device (301). Outlet hot lines (111B) and (113B) transmit current from the depicted device (301) to a second three-way switch (109B) situated between the depicted device (301) and the load (107). It is important to understand that the depicted device (301) need not have any knowledge of the state of the other three-way switches (109A) and (109B) in the circuit. The depicted device (301) detects whether the load (107) is receiving power by

detecting current on the neutral wire (105). In the depicted embodiment, this is done using a current sensor (321).

[031] In the depicted device (301), switching is provided by a conventional four-way double pole/double throw switch (303) operatively connected to a logic unit (305) and a computer system (307). The logic unit (305) generally issues instructions to the switch (303) to change its state. The computer system (307) is generally an embedded system (307) comprising a wireless telecommunication systems, such as a WiFi®, BlueTooth®, cellular, or other transmitter/receiver system, as well as a processor and storage medium. This system (307) is a controller, and also includes components, circuitry, and programming to receive, send, and process messages and instructions, and to communicate with other components of the device (301). The computer (307) may transmit information, such as system status, to remote devices (403). In an embodiment, logic unit (305) and CPU (307) may be combined into a single unit.

[032] In the depicted embodiment, the logic unit (305) and computer system (307) are preferably supplied continuous power. However, due to the nature of four-way switch geometry, at any given moment in time, power may be on either the black wire (111A) or the red wire (113A). Further, the power on these wires (111A) and (113A) is typically alternating current (“AC”), whereas, logic unit (305) and computer system (307) typically require direct current (“DC”). The device (301) may further include appropriate hardware and circuitry for converting AC to DC (not depicted). The device (301) further comprises wiring or circuitry for transmitting the converted DC to the logic unit (305) from either/both the black (111A) and/or red (113A) wires, ensuring that, regardless of which wire (111A) and (113A) has power, the logic unit (305) is powered. Power may also be transmitted to the computer system (307) in similar fashion. To complete the circuit, neutral lines carry power from the logic unit (305) and computer system (307) back to the neutral main (105).

Although in the depicted embodiment of FIG. 3, the logic unit (305) and computer system (307) are wired in serial, alternative wiring geometries are possible, such as but not necessarily limited to, parallel.

[033] To prevent backflow of current, one or more diodes (331) may be included in the wiring geometry and/or circuitry. In the depicted embodiment, two diodes (331) are positioned in the circuit between the AC/DC converter (not depicted) and the logic unit (305) and/or computer system (307), one each for the black (111A) and red (113A) power lines. This prevents backflow when the incoming power switches from black to red or red to black. In such an embodiment, neutral wires from the logic unit (305) or computer (307) may be directed back into the diodes (311) and from there to the neutral main (105).

[034] The depicted geometry of FIG. 3 ensures that, regardless of the switch state of the overall circuit, a complete circuit power circuit is provided for at least the logic unit (305) and computer system (317), allowing those components to operate regardless of the switch (303) state, and regardless of which incoming hot wire (111A) and (113A) has power. In the depicted embodiment, the logic unit (305) and computer system (307) are operatively coupled to a current sensor (321), allowing for the detection of power from the load (107). If no current is detected from the load (107), the system can detect that power is off in the overall circuit, whereas if there is power on the neutral wire (105), the system detects that the load (107) is receiving power. Another function of wiring the logic unit (305) or the computer (307) to the current sensor (321) is that the current sensor (321) may detect whether power is coming from the logic unit (305) and/or computer (307). If not, this is generally considered an error state.

[035] The device (301) operates by determining and storing the state of the load (107) (on or off), storing the state of the load, and accessing the stored state. When receiving a command indicating a state the circuit should be changed to (on or off), then the system

operates the switch (303) only if the desired or final state differs from the current state. This is done by detecting current on the neutral wire (105), which should generally have high current only if the load (107) is powered. A break in the circuit at any point – whether at the first three-way switch (109A), the second three-way switch (109B), or the device (301) switch (303) – will cause the load (107) to be unpowered, and thus there will be little or no current on the neutral wire (105). The system (301) thus has access to state information through the load status (107), regardless of the status of the other switch components (109A) and (109B) in the overall circuit. Since toggling any switch (109A), (109B), or (303) in the system will cause a change in the load (107) state, switch (303) may be operated to change the load state regardless of the status of the other switches (109A) and (109B). Thus, only one switch in the overall circuit need be replaced with the intelligent device (301) of the present disclosure.

[036] This may be clarified through use of an illustrative, non-limiting example. Beginning with a prior art four-way switch geometry, such as that depicted in FIG. 2, a user replaces in this illustrative example the four-way switch (115) with the intelligent device (301) depicted in FIG. 3. The depicted device (301) of FIG. 3 may be implemented as a generally self-contained unit (301), similar to conventional switches, or may have external components. Installation of the device (301) generally comprises attaching the incoming (111A) and (113A) and outgoing (111B) and (113B) lines to the appropriate end of the switch system, along with the neutral wire (105). One difference between the depicted embodiment and a conventional four-way switch is that with a conventional four-way switch, it typically does not matter which end is which; that is, the incoming/outgoing lines may be attached to either set of posts on the switch and the system will function. However, directionality could be relevant to installation geometry in the depicted embodiment if dimmers (309) are present.

[037] The circuit is typically powered down during installation. After the installation is finished and the circuit is powered on, power will flow in from either the black (111A) or red (113A) main, depending on the state of the first three-way switch (109A). There may or may not be current on the neutral line (105) again depending on the overall system state. If current is detected on the neutral line (105), such as by the current sensor (321), this information is transmitted to the logic unit (305) and/or computer system (307), which can then save in memory that the current system state is “on.” Alternatively, if no current is detected, the current state of “off” is stored. In either case, without knowing the status of the other two switches (109A) and (109B), the computer system (307) can determine the overall system state.

[038] Thus, if the computer (307) receives instructions to toggle the system, the computer (307) can cause logic unit (305) to throw the switch (303), thus toggling the system state. If the system was previously on (i.e., power to the load), it will turn off, and vice versa. This will occur regardless of the status of the other switches (109A) and (109B) because in a four-way wiring geometry, any one of the switches (109A), (109B) or (303) can toggle system state, including the four-way switch (303).

[039] More advanced operations and intelligence are possible as well. For example, the instructions received by the computer system (307) may be to turn the system on, meaning that the computer system (307) only toggles the switch (303) if the system is not already on. Thus, the computer system (307) comprises program logic to examine (or detect) the current system state (on or off) and cause logic unit (305) to throw switch (303) only if the system is currently off. If the system is currently on, then no action need be taken because the system is already in the desired final state indicated by the request. Similar logic may be used to turn the system off.

[040] This feature may be combined with other features to create complex system logic. For example, the computer system (307) may have an internal chronometer, or may access an external chronometer through a network (405) connection, such as by using the universal time protocol to access a public time server. With access to date and time information, the computer (307) may comprise programming to carry out specific operations at specific dates and times. For example, the computer (307) may be instructed to turn on or turn off at a particular time each day. Because the current state is known and/or can be determined, the above program logic may be used to the throw switch (303) or not, depending on whether a change of state is needed to achieve the desired state.

[041] Again, it is important to understand that, due to the structure of the intelligent switch device (301), these features can be implemented in a multi-way switch by replacing only one of the mechanical switch components. The other mechanical switches will continue to operate as desired and expected by users.

[042] In an embodiment, the device (301) can detect error conditions. By way of example and not limitation, if a state change is required to respond to a command, and the switch (303) is thrown, this should cause a change in state on the neutral wire (107). If no such change is detected, an error has occurred. This error may be transmitted or otherwise indicated, such as through use of an LED or other light embedded in the device (301) or by transmitting an error message.

[043] In an embodiment, a dimming circuit (309) may be included. This element (309) is generally situated between the switch (303) and the power circuit for the logic unit (305) and computer system (307), so that changes in power output caused by the dimmer do not impact performance of the logic unit (305) and computer system (307).

[044] The depicted system (301) may be used in any position in a multi-way circuit. One of ordinary skill in the art will understand that this may be done by simply not connecting one of

the poles of the four-way switch (303) component for the red line (113A) or (113B). Additionally, the depicted system (301) may be used as the only switching element in the network, allowing it to be utilized without hardware changes in any place a previous mechanical switch existed.

[045] An aspect of the present disclosure is that the intelligent switching system (301) receives commands or instructions from an external source. Although this can be done through a wired configuration, in the preferred embodiment, signals are received wirelessly. FIG. 4 depicts an embodiment of a wireless system. In the depicted embodiment of FIG. 4, the intelligent switch system (301) is installed in an electrical system (not depicted) and is in wireless communication with a user device (403) over a telecommunications network (405). The depicted telecommunications network (405) is a wide-area network, such as the Internet. Alternatively, the system (301) may communicate with a user device (403) directly (415), such as by using a short-range protocol like BlueTooth® or near-field communication. Alternatively, the system (301) may communicate with a user device (403) locally (417) such as by sending and receiving communications (417) and (411) through a local access point or router (407). The particular communications channels used depend in part on where the device is located, and how it is capable of communicating. A device outside the transmission range of short-range transmitters may use a wide-area telecommunications network (405) instead.

[046] The user device (403) is depicted as a mobile phone or smart phone and will generally comprise a computer system. A computer-based user device (403) will generally comprise programming instructions for connecting to and synchronizing with the system (301), wirelessly exchanging data with the system (301), and providing a user interface for accepting user instructions and translating them into commands sent to the system (301), and for displaying status information about the system based on status data received from the

system (301). In an alternative embodiment, the user device (403) may be a special-purpose or limited-purpose device configured to interact with the system (301), such as a remote control.

[047] A further aspect of the present disclosure is that certain safety considerations may render it desirable to replace a specific or particular switch in the original circuit. For example, the device (301) could place a circuit into safety mode if it is in the final position before the load (107) (i.e., the last switching device before power is transmitted to the load), such as the second three-way switch (109B). In an embodiment, the device (301) includes programming logic to determine whether the device (301) is in the last position such that the safety feature will function.

[048] This may be done by examining the state of other elements of the circuit and calculating a probability. For example, the computer (307) may comprise programming for a confidence-building learning algorithm which develops probabilities based on data gathered during normal operations. Alternatively, or additionally, the computer (307) may comprise programming for determining where the device is in the system in response to a set of switch clicks. In a still further embodiment, the device (301) may sense the presence of voltage and/or current to determine if it is in the last position, such as comparing power on the red and black lines to the voltage sensor state. While certain combinations of readings are non-deterministic, position can generally be inferred from such readings.

[049] For example, if the voltage input to the device (301) changes generally at the same time as the current state on the neutral line, and the device (301) switch state has not changed, it may be inferred that another switch earlier in the circuit has been toggled. This in turn means that it may be inferred that the device (301) is in either the middle or last position, and thus there is a 50/50 chance the device is last. However, if the voltage input line does not change and there is a change in the current flow through the neutral line to a low state (301),

it cannot necessarily be inferred that a later switch caused the change, as the load may be removed, damaged, or otherwise broken the circuit (e.g., a light bulb burned out). If the system continues to detect that current changes on the neutral coincide with voltage input changes, and there are never current changes on the neutral without a corresponding voltage input location change excluding those changes caused by actuations of the device (301) itself, each such instance may be inferred to make it more and more likely that the device is in the final position.

[050] Alternatively, the user may cooperate with the system through guided instructions to operate each switch in the circuit in a systematic fashion, ensuring that every state of the system is tested and allowing the program logic to confirm that the system is (or is not) last in the circuit. Other forms of testing or providing such information could also be used, such as the user simply providing an indication to the computer (307), directly or indirectly, of the state/position.

[051] If a dimming circuit is included, the device (301) may further enter safety mode, regardless of switch location, by simply reducing the dimmed power level to zero (or effectively zero) on both lines. This effectively removes power from the circuit, allowing the system to conclude no power is present at the fixtures or loads.

[052] While the invention has been disclosed in conjunction with a description of certain embodiments, including those that are currently believed to be preferred embodiments, the detailed description is intended to be illustrative and should not be understood to limit the scope of the present disclosure. As would be understood by one of ordinary skill in the art, embodiments other than those described in detail herein are encompassed by the present invention. Modifications and variations of the described embodiments may be made without departing from the spirit and scope of the invention.

## CLAIMS

1. An intelligent electrical switching device comprising:
  - a mechanical electrical switch, said mechanical electrical switch being in an operational state;
  - a logic unit operatively coupled to said mechanical electrical switch such that said logic unit is operable to cause said mechanical electrical switch to change said operational state;
  - a computer system coupled to said logic unit and comprising a wireless transmitter/receiver operable to send and receive data over a telecommunications network, said computer system comprising a non-transitory machine-readable storage medium having stored thereon computer program instructions for causing the intelligent electrical switching device to perform the steps of:
    - wirelessly receiving instructions to set the power state of a circuit in which said device is installed to a desired power state, said desired power state being indicated in said received instructions;
    - detecting whether said circuit is in said desired powered state;
    - only if said circuit is detected as not being in said desired powered state, said logic unit operating said mechanical electrical switch to change said operational state.
2. The device of claim 1, wherein said mechanical electrical switch is a double pole/double throw switch.
3. The device of claim 1, wherein said mechanical electrical switch is capable of being in exactly one operational state.
4. The device of claim 1, wherein detecting whether said circuit is in said desired powered state comprises sensing current on a neutral line of said circuit using a current sensor operatively coupled to said computer system.

5. The device of claim 1, wherein said computer system is an embedded system.
6. The device of claim 1, wherein said operational state is selected from the group consisting of: open and closed.
7. The device of claim 6, wherein said program step of said logic unit operating said mechanical electrical switch to change said operational state comprises toggling said operational state.
8. The device of claim 1, said device further comprising:
  - a first power input line;
  - a power converter disposed on said first power input line, said power converter converting alternating current to direct current;
  - a direct current line transmitting current from said power converter to said logic unit when said device receives power on said first power input line.
9. The device of claim 8, said device further comprising:
  - a second power input line;
  - a second power converter disposed on said second power input line, said second power converter converting alternating current to direct current;
  - a second direct current line transmitting current from said second power converter to said logic unit when said device receives power on said second power input line.
10. The device of claim 9, wherein said mechanical electrical switch, said logic unit, and said computer system are contained in a housing sized and shaped for installation in an electrical box.
11. The device of claim 10, wherein said housing comprises:
  - a first power input post transmitting power to said first power input line when power is transmitted to said first power input post;

a second power input post transmitting power to said second power input line when power is transmitted to said second power input post.

12. The device of claim 9, said device further comprising:

a voltage sensor disposed on said second power input line and sensing the amount of voltage on said second power input line;

said computer system further comprising computer program instructions for causing the intelligent electrical switching device to perform the steps of:

determining a probability that said device is installed in a switching position immediately prior to a load in said circuit based at least in part on voltage readings received from said voltage sensor.

13. The device of claim 1, further comprising a dimming circuit operable to reduce the amount of power transmitted from the device.

14. The device of claim 13, wherein said dimming circuit is operable to reduce the amount of power transmitted from the device to zero.

15. The device of claim 1, wherein said logic unit and said computer system comprise a single component.

16. An electrical system comprising:

at least one intelligent electrical switching device comprising:

a mechanical electrical switch, said mechanical electrical switch being in an operational state;

a logic unit operatively coupled to said mechanical electrical switch such that said logic unit is operable to cause said mechanical electrical switch to change said operational state;

a computer system coupled to said logic unit and comprising a wireless transmitter/receiver operable to send and receive data over a telecommunications network,

said computer system comprising a non-transitory machine-readable storage medium having stored thereon computer program instructions for causing the intelligent electrical switching device to perform the steps of:

wirelessly receiving instructions to set the power state of a circuit in which said device is installed to a desired power state, said desired power state being indicated in said received instructions;

detecting whether said circuit is in said desired powered state;

only if said circuit is detected as not being in said desired powered state, said logic unit operating said mechanical electrical switch to change said operational state;

at least one mechanical electrical switching device;

wherein said at least one intelligent electrical switching device and said at least one mechanical electrical switching device are in electrical communication with a single load in a multi-way switching geometry.

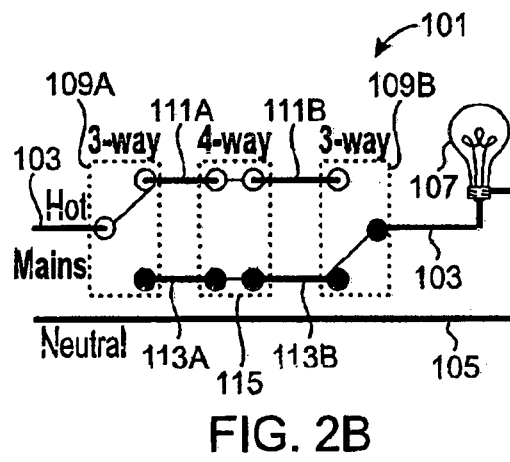
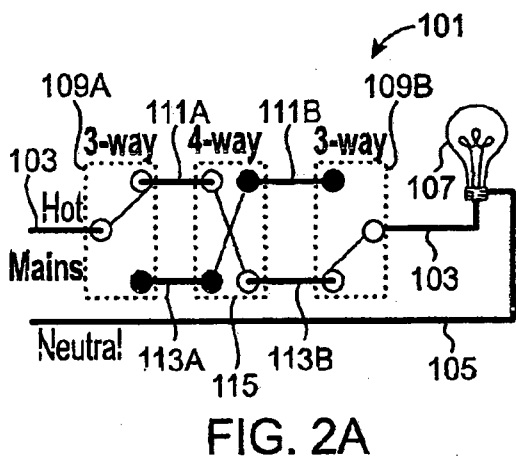
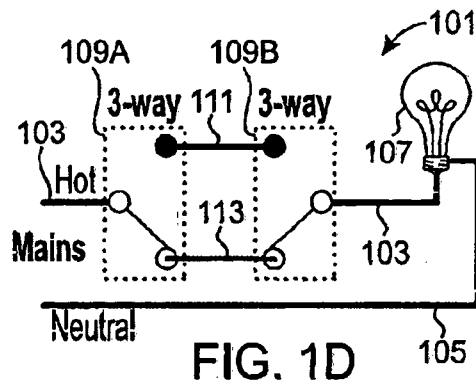
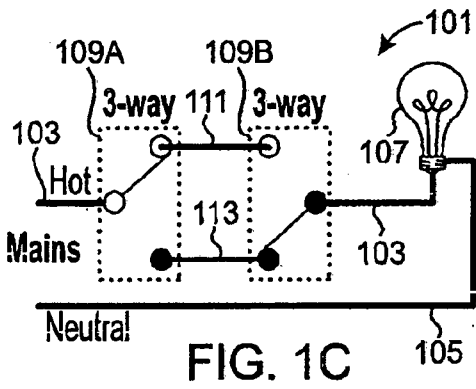
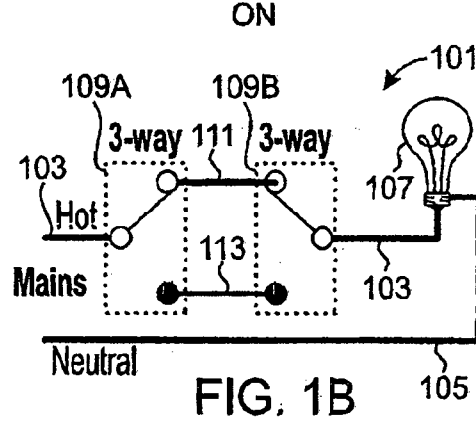
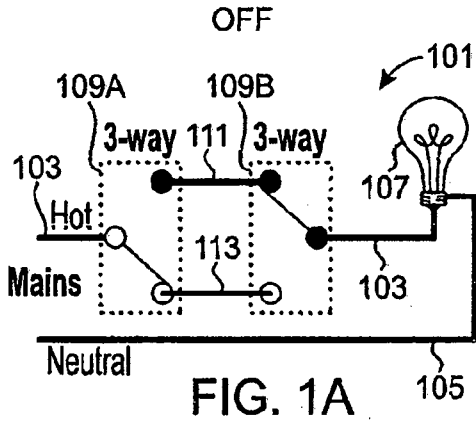

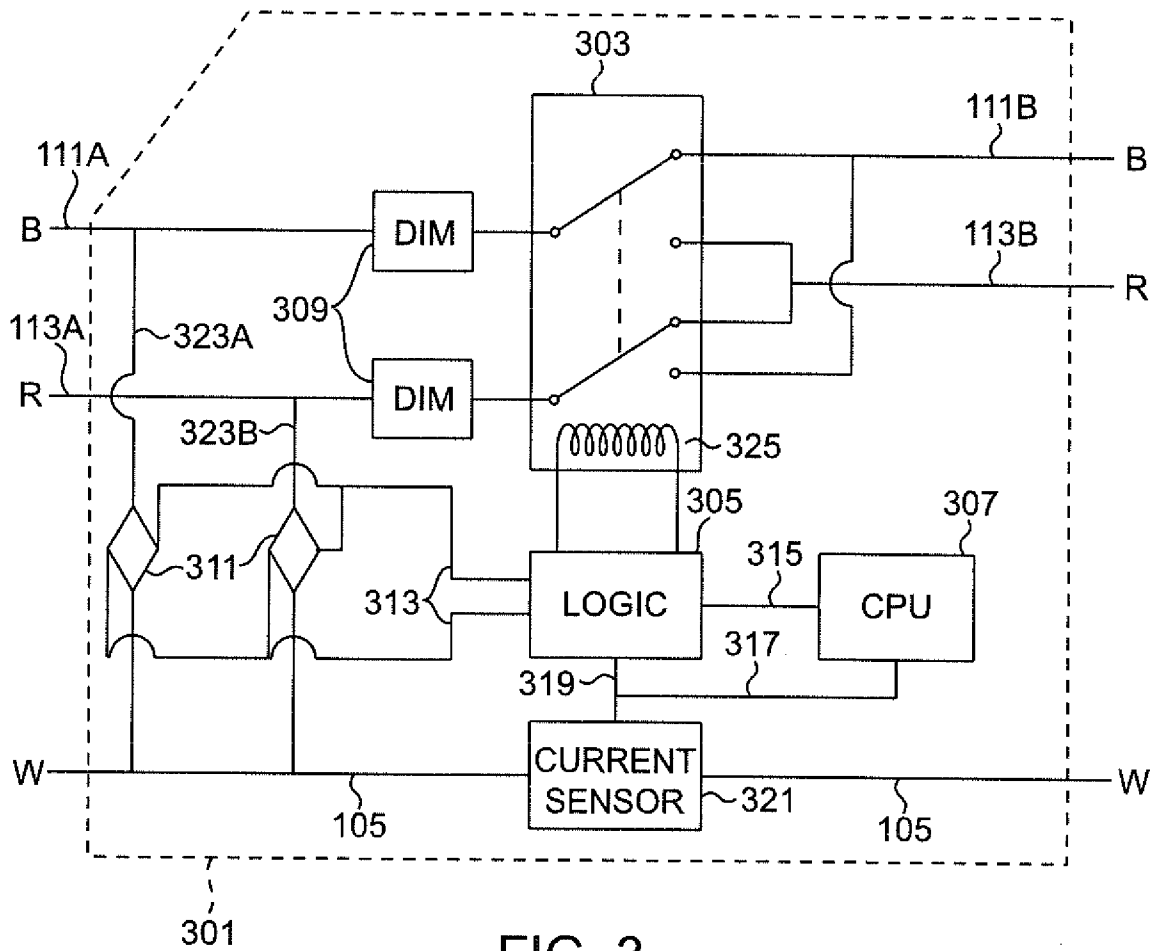

FIG. 3

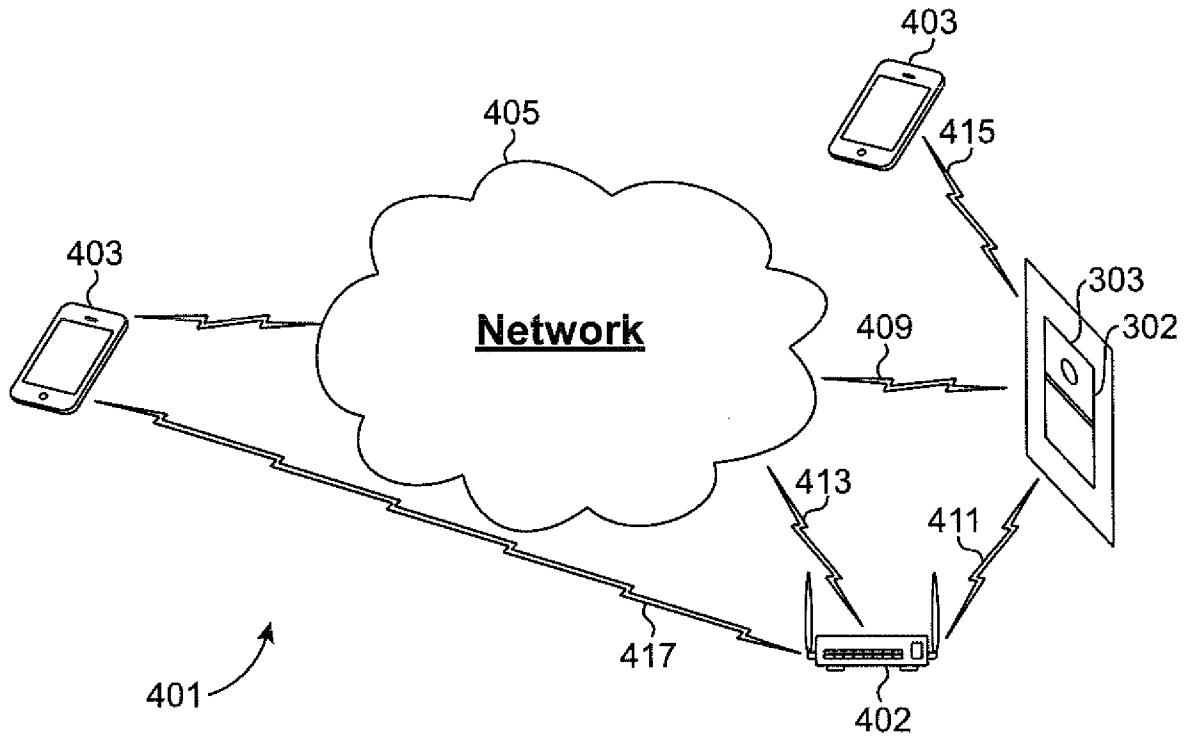

FIG. 4

**A. CLASSIFICATION OF SUBJECT MATTER****H03K 17/94(2006.01)i, H03K 17/06(2006.01)j**

According to International Patent Classification (IPC) or to both national classification and IPC

**B. FIELDS SEARCHED**Minimum documentation searched (classification system followed by classification symbols)  
H03K 17/94; H04B 1/16; H04W 92/02; H01H 47/22; H04B 1/38; H03K 7/06; H03K 17/06Documentation searched other than minimum documentation to the extent that such documents are included in the fields searched  
Korean utility models and applications for utility models  
Japanese utility models and applications for utility modelsElectronic data base consulted during the international search (name of data base and, where practicable, search terms used)  
eKOMPASS(KIPO internal) & Keywords: switch, wireless, transceiver, computer, circuit, power, threshold, mode, logic, pole, throw, instruction**C. DOCUMENTS CONSIDERED TO BE RELEVANT**

Category*	Citation of document, with indication, where appropriate, of the relevant passages	Relevant to claim No.
Y	US 2011-0141647 A1 (BEN L. GARCIA et al.) 16 June 2011 See paragraphs [0021]-[0040], [0053]-[0071] and figures 1-6.	1-16
Y	US 2012-0046003 A1 (ZHINONG YING) 23 February 2012 See paragraphs [0053]-[0072] and figures 2A-4.	1-16
A	US 2013-0295866 A1 (CHENGJIE ZUO et al.) 07 November 2013 See abstract, paragraphs [0025]-[0050] and figures 1-6.	1-16
A	US 2009-0080568 A1 (CHONG U. LEE et al.) 26 March 2009 See abstract, paragraphs [0037]-[0080] and figures 1-12.	1-16
A	KR 10-2013-0048553 A (HYUNDAI MOBIS CO., LTD.) 10 May 2013 See abstract, paragraphs [0020]-[0043] and figure 2.	1-16

 Further documents are listed in the continuation of Box C. See patent family annex.

\* Special categories of cited documents:

"A" document defining the general state of the art which is not considered to be of particular relevance

"E" earlier application or patent but published on or after the international filing date

"L" document which may throw doubts on priority claim(s) or which is cited to establish the publication date of another citation or other special reason (as specified)

"O" document referring to an oral disclosure, use, exhibition or other means

"P" document published prior to the international filing date but later than the priority date claimed

"T" later document published after the international filing date or priority date and not in conflict with the application but cited to understand the principle or theory underlying the invention

"X" document of particular relevance; the claimed invention cannot be considered novel or cannot be considered to involve an inventive step when the document is taken alone

"Y" document of particular relevance; the claimed invention cannot be considered to involve an inventive step when the document is combined with one or more other such documents, such combination being obvious to a person skilled in the art

"&amp;" document member of the same patent family

Date of the actual completion of the international search

04 February 2016 (04.02.2016)

Date of mailing of the international search report

**05 February 2016 (05.02.2016)**

Name and mailing address of the ISA/KR

International Application Division  
Korean Intellectual Property Office  
189 Cheongsa-ro, Seo-gu, Daejeon, 35208, Republic of Korea

Facsimile No. +82-42-472-7140

Authorized officer

KIM, Sung Gon

Telephone No. +82-42-481-8746

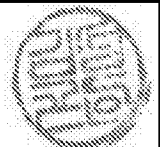

## INTERNATIONAL SEARCH REPORT

Information on patent family members

International application No.

**PCT/US2015/057869**

Patent document cited in search report	Publication date	Patent family member(s)	Publication date
US 2011-0141647 A1	16/06/2011	CA 2707873 A1 US 8373313 B2	15/12/2010 12/02/2013
US 2012-0046003 A1	23/02/2012	EP 2424125 A1 US 8351849 B2	29/02/2012 08/01/2013
US 2013-0295866 A1	07/11/2013	CN 104272597 A EP 2845320 A1 JP 2015-517753 A KR 10-2015-0006875 A US 2015-215026 A1 US 9008602 B2 WO 2013-166486 A1	07/01/2015 11/03/2015 22/06/2015 19/01/2015 30/07/2015 14/04/2015 07/11/2013
US 2009-0080568 A1	26/03/2009	CN101803193 A CN101803194 A CN101803195 A EP 2191571 A1 EP 2191571 B1 EP 2191572 A1 EP 2201687 A1 JP 05490699 B2 JP 05815608 B2 JP 2010-541320 A JP 2010-541321 A JP 2010-541322 A JP 2014-014081 A JP 2015-015725 A KR 10-1148348 B1 KR 10-1172961 B1 KR 10-1537012 B1 KR 10-2010-0057693 A US 2009-0079486 A1 US 2009-0080101 A1 US 7965805 B2 US 8385474 B2 US 8446976 B2 WO 2009-038587 A1 WO 2009-038588 A1 WO 2009-038589 A1	11/08/2010 11/08/2010 11/08/2010 02/06/2010 20/11/2013 02/06/2010 30/06/2010 14/05/2014 17/11/2015 24/12/2010 24/12/2010 24/12/2010 23/01/2014 22/01/2015 21/05/2012 09/08/2012 16/07/2015 31/05/2010 26/03/2009 26/03/2009 21/06/2011 26/02/2013 21/05/2013 26/03/2009 26/03/2009 26/03/2009
KR 10-2013-0048553 A	10/05/2013	None	