

GUION & WOMBAUGH.

Lamp.

No. 15,636.

Patented Aug. 26, 1856.

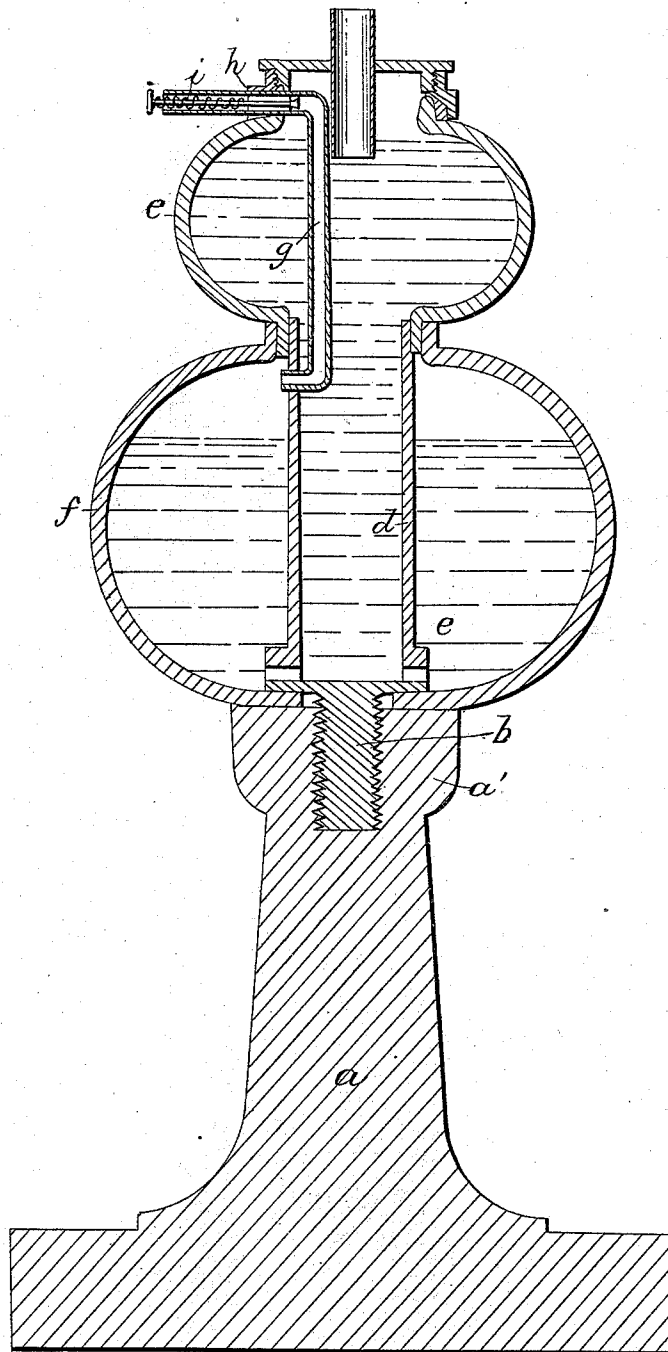

UNITED STATES PATENT OFFICE.

PETER C. GUION AND PAUL K. WOMBAUGH, OF CINCINNATI, OHIO, ASSIGNOR TO P. K. WOMBAUGH, OF SAME PLACE.

LAMP.

Specification of Letters Patent No. 15,636, dated August 26, 1856.

To all whom it may concern:

Be it known that we, PETER C. GUION and PAUL K. WOMBAUGH, both of Cincinnati, Hamilton county, Ohio, have invented a new and useful Improvement in Lamps, styled by us "The Elastic Air-Pressure Lamp;" and we do hereby declare the following to be a full, clear, and exact description thereof, reference being had to the annexed drawings, making part of this specification, and in which our device is represented by an axial section.

Our improvement has for its chief features, an elastic and impervious bulb of india rubber gutta percha or like elastic and impervious substance, in connection with an arrangement of an air duct by which by the simple pressure of the thumb and finger upon the bulb, the combustible is maintained in favorable contact with the wick.

The lamp is constructed as follows: A foot (*a*) has in its top a hollow screw (*a'*) to receive the screw threaded tower extremity of a hollow stem (*b c d*) which at its upper end supports and opens into the bowl (*e*) of the lamp. To a flange projecting downward from this bowl there is attached the upper margin of the elastic bulb (*f*) its lower margin being secured by the screwing down of the stem to the foot, the margin of the bulb being clamped between these two parts. The stem at its lower end communicates by apertures (*c*) with the interior of the bulb, and the upper end of the stem being open as described there is thus a direct passage afforded from the bulb into the bowl.

(*g*) is an air duct which penetrating the neck descends through the bowl and passes into the upper part of the bulb. This duct has an inwardly opening valve (*h*) which may be held to its seat by a spiral spring (*i*) or its equivalent.

The operation of the lamp is as follows: The burner being removed, the whole in-

terior of the bowl and stem, and bulb, is filled with the combustible liquid poured in through the bowl, the valve (*h*) being temporarily opened by pressure of the thumb against its stem, just long enough to allow the entering combustible to drive out what air there may have been contained in the bulb. Then the burners having been replaced—and the combustion taking place—when the lamp has been some time in action and it is desired to replenish the bowl, the object is accomplished by simply grasping the bulb and thus forcing a portion of its liquid contents to flow up through the stem and into the bowl; then the pressure being withdrawn, the bulb resumes its former shape, and in so doing draws in a fresh supply of air through the air duct, the valve opening for that purpose; the much greater inertia of the liquid forbidding its return during the instant that the air thus supplies the void created by the expanding bulb.

A lamp of such construction can thus by an occasional grasp of the bulb have its combustible fluid maintained in efficient contact with the burner—so long as any fluid remains in the bulb.

We claim as new and of our invention herein—

The elastic bulb or reservoir (*f*) surrounding and communicating at bottom with a hollow stem (*b c d*) which supports and opens into the bowl; in the described combination with the air duct (*g*) having an inwardly opening valve (*h*) affording the described means of communication from the external atmosphere to the upper part of the bulb, or equivalent devices for the purposes explained.

In testimony whereof, we hereunto set our hands before two subscribing witnesses.

P. C. GUION.

PAUL K. WOMBAUGH.

Witnesses:

GEO. H. KNIGHT,
JAS. D. GRIDLY.