

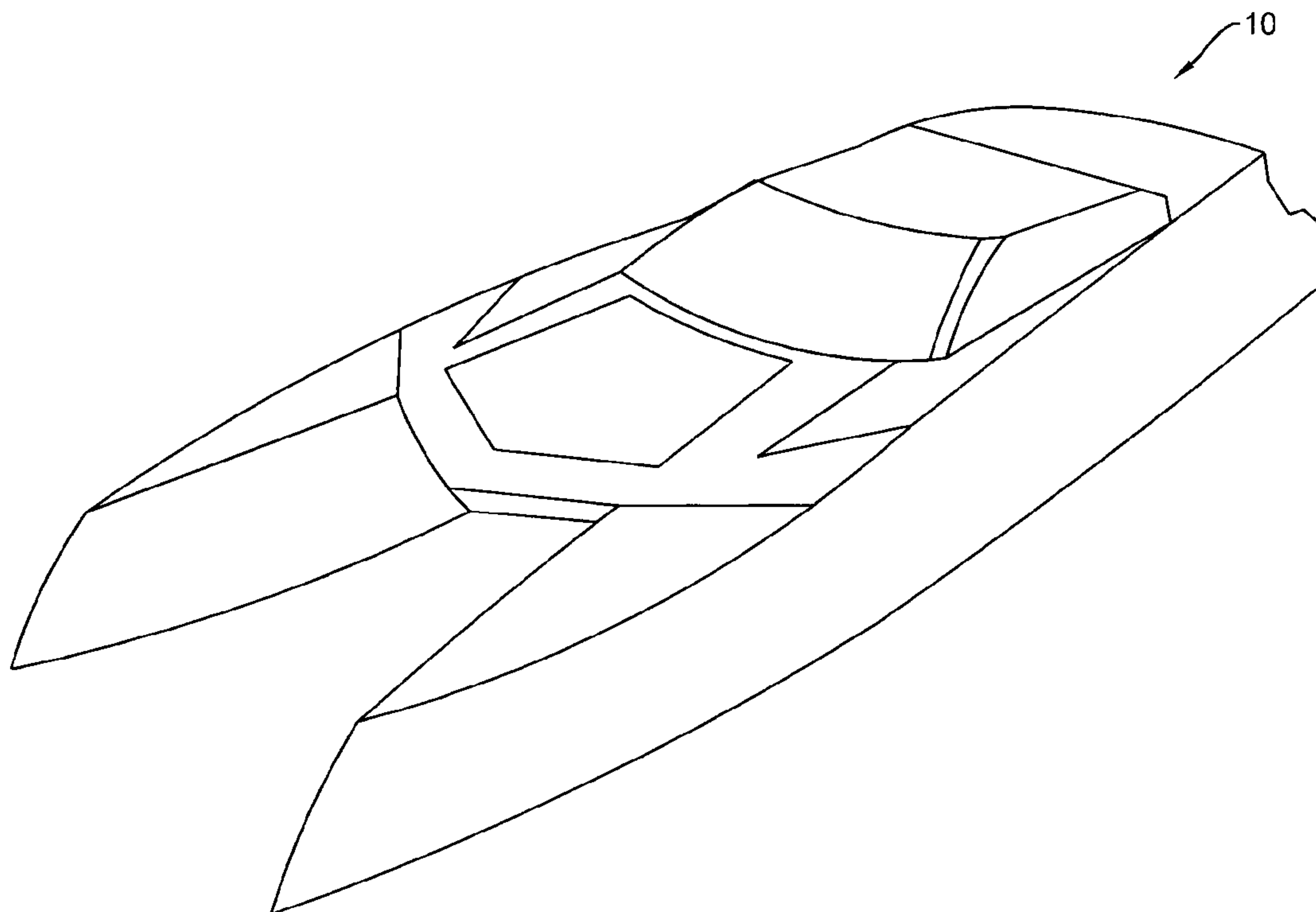

(86) Date de dépôt PCT/PCT Filing Date: 2017/06/27  
(87) Date publication PCT/PCT Publication Date: 2018/01/25  
(45) Date de délivrance/Issue Date: 2019/10/29  
(85) Entrée phase nationale/National Entry: 2018/12/07  
(86) N° demande PCT/PCT Application No.: CA 2017/050781  
(87) N° publication PCT/PCT Publication No.: 2018/014112  
(30) Priorité/Priority: 2016/07/19 (US15/214,281)

(51) Cl.Int./Int.Cl. *B63B 1/12* (2006.01),  
*B63B 1/32* (2006.01), *B63B 3/08* (2006.01),  
*B63B 43/10* (2006.01)  
(72) Inventeur/Inventor:  
SYRYDA, BRENDON, CA  
(73) Propriétaire/Owner:  
SYRYDA, BRENDON, CA  
(74) Agent: OKIMAW, RICHARD D.

(54) Titre : COQUE DE BATEAU TRANSFORMABLE  
(54) Title: CONVERTIBLE BOAT HULL



(57) **Abrégé/Abstract:**

A boat hull comprises a central hull having top and bottom portions and first and second side hulls slidably supported from the top portion of the central hull so as to be transversely extendable relative thereto. The bottom portion of the central hull is rotatably connected to the top portion so as to be movable between raised and lowered positions. A method of reconfiguring the boat hull comprises slidably displacing first and second side hulls relative to a central hull and rotatably displacing a bottom portion of the central hull relative to a top portion from a raised position to a lowered position between the first and second side hulls.

-12-

**ABSTRACT**

5 A boat hull comprises a central hull having top and bottom portions and first and second side hulls slidably supported from the top portion of the central hull so as to be transversely extendable relative thereto. The bottom portion of the central hull is rotatably connected to the top portion so as to be movable between raised and lowered positions. A method of reconfiguring the boat hull comprises slidably displacing first and second side hulls relative to a central hull and rotatably displacing a bottom portion of the central hull relative to a top portion from a raised position to a lowered position between the first and second side hulls.

10

## CONVERTIBLE BOAT HULL

### BACKGROUND OF THE INVENTION

#### 1. Field of Invention

5 The present invention relates generally to boats and in particular to boats that may be converted into multiple hull configurations.

#### 2. Description of Related Art

10 Recreational boats are available with a variety of hull configurations. Each configuration has benefits for different uses and conditions. In particular, shallow multihull boats have great stability, particularly at low speeds and at rest. These boats are desirable for fishing or cruising on calm waters, are well suited for coaching of various watersports due to their low wake, and can also achieve high speeds with relatively low wake. Water skiers prefer low wake to  
15 enable carving of turns, thus a shallow multihull boat is desirable for this sport.

Deep vee bottomed boat hulls are advantageous at high speeds and in rough water conditions. They can also create a significant amount of wake, which is desirable for wakeboarding. At lower speeds this design has less stability, and  
20 is therefore less desirable for low speed or at rest recreational uses, such as fishing, low speed cruising or resting at anchor.

Both deep vee bottom and shallow multihull boats have advantages. Rather than utilize multiple boats to meet the needs of all water sport enthusiasts, boats  
25 with convertible boat hulls allowing multiple hull profiles are desirable. Previous attempts have been made to allow conversion between two different hull shapes, however such attempts have not been satisfactory.

30 Some previous convertible boat hull attempts have included designs which modify the shape of a single hull, but do not include multiple hulls. Examples of such are U.S. Pat. Nos. **6,223,674 B1** to Wyman et al. and U.S. Pat. No. **3,559,222** to Walker.

Other attempts have included the ability to adjust the configuration of multiple hulls, such as described in U.S. Pat. No. **2012/0024211 A1**, Wiltse, but stabilizers remain present in all configurations. Additionally, the movement of the pontoons or stabilizers in such designs is largely vertical and does not affect the overall width of the boat.

The configuration illustrated in U.S. Pat. No. **6,619,224 B1**, Syfritt, similarly does not significantly affect the overall width of the boat between the two configurations. Additionally, this design includes only one bow.

### **SUMMARY OF THE INVENTION**

According to a first embodiment of the present invention there is disclosed a boat hull comprising a central hull having top and bottom portions and first and second side hulls slidably supported from the top portion of the central hull so as to be transversely extendable relative thereto. The bottom portion of the central hull is rotatably connected to the top portion so as to be movable between raised and lowered positions.

The first and second side hulls may be positioned outside the bottom portion of the central hull at the lowered position. The bottom portion of the central hull may be nested within the first and second side hulls at the raised position. The boat hull may further comprise at least one actuator for extending the first and second side hulls relative to the central hull.

The bottom portion of the central hull may be rotatable relative to the top portion about an axis. The axis may be horizontal. The axis may be located proximate to a leading edge of the bottom portion. The bottom portion may have an angular orientation relative to horizontal greater at the lowered position than at the raised position.

The boat hull may further comprise an actuator for extending the bottom portion between the raised and lowered positions. The bottom portion may be abutable against and alignable with the first and second side hulls such that a

-3-

bottom running surface of the bottom portion is continuous with corresponding bottom running surfaces of the side hulls at the lowered position. The bottom portion of the central hull may be positionable at an intermediate position between the raised and lowered positions. The bottom portion may be abutable against and alignable with the first and second side hulls at the intermediate position so as to form a continuous bottom running surface therebetween. The boat hull may further comprise a motor and drive assembly supported on the bottom portion of the central hull.

According to a further embodiment of the present invention there is disclosed a method of reconfiguring a boat hull comprising providing a central hull having top and bottom portions and providing first and second side hulls slidably supported from the top portion of the central hull so as to be transversely extendable relative thereto. The bottom portion of the central hull is rotatably connected to the top portion so as to be movable between raised and lowered positions.

According to a further embodiment of the present invention there is disclosed a method of reconfiguring a boat hull comprising slidably displacing first and second side hulls relative to a central hull and rotatably displacing a bottom portion of the central hull relative to a top portion from a raised position to a lowered position between the first and second side hulls.

Other aspects and features of the present invention will become apparent to those ordinarily skilled in the art upon review of the following description of specific embodiments of the invention in conjunction with the accompanying figures.

### **BRIEF DESCRIPTION OF THE DRAWINGS**

In drawings which illustrate embodiments of the invention wherein similar characters of reference denote corresponding parts in each view,

Figure 1 is a diagrammatic perspective view of a marine vessel with a convertible hull.

-4-

Figure 2 is a side view of the marine vessel of Figure 1, in a first or shallow hull configuration.

Figure 3 is a side view of the marine vessel of Figure 1, in a third or deep vee hull configuration.

5 Figure 4 is an aft view of the marine vessel of Figure 1, in the first hull configuration.

Figure 5 is an aft view of the marine vessel of Figure 1, in a second or wide beam shallow hull configuration.

10 Figure 6 is an aft view of the marine vessel of Figure 1, in a third hull configuration.

Figure 7 is an aft view of the marine vessel of Figure 1, in a fourth or mid-level vee hull configuration.

Figure 8 is a bottom view of the marine vessel of Figure 1 in a third hull configuration.

15

#### **DETAILED DESCRIPTION**

Referring to Figure 1, a multihull marine vessel with a convertible hull according to a first embodiment of the invention is shown generally at 10. As best seen in Figures 4, 5 and 6, the marine vessel 10 comprises a plurality of hulls, including first and second side hulls 12 and 14, respectively, and a central hull 16 therebetween. As will be described in more detail below, the first and second side hulls 12 and 14 can be adjusted in lateral position, and the central hull 16 can be adjusted in vertical position, thereby altering the overall hull configuration of the marine vessel 10.

25

Turning to Figure 8, the marine vessel 10 has fore end indicated at 20, aft end indicated at 22, first or port side 24 and second or starboard side 26. The first and second side hulls 12 and 14, having first and second side hull keels 32 and 34, respectively, as shown on Figures 4-7, are positioned proximate to first and second sides 24 and 26, respectively, and extend substantially from fore end 20 to aft end 22. The central hull 16, having central hull keel 36, as shown on Figures 4-7, extends substantially from central hull front end 28 to aft end 22, and is positioned centrally between first and second side hulls 12 and 14. The

30

central hull **16** includes a motor and drive assembly **18** therein. As illustrated in Figures **1** and **8**, the central hull front end **28** may be positioned rearwardly of the fore end **20** of the vessel.

5 When in the first or second positions, as shown in Figures **4** and **5**, the exterior of the hull has a generally trimaran shape, with the first and second side hulls **12** and **14** being generally the same shape and size, and the central hull **16** formed in a vee shape therebetween. The central hull **16** extends between first and second side hulls, **12** and **14**, and includes a central hull top portion **46** and  
10 central hull bottom portion **48**, respectively, wherein the central hull bottom portion **48** extends to a central keel **36**. The central hull **16** is shallower than the first and second side hulls throughout its length, from central hull front end **28** to aft end **22**, with the central hull keel **36** substantially parallel to the first and second side hull keels **32** and **34**. The central hull keel **36** extends substantially  
15 from the central hull keel front end **29** to aft end **22**. As illustrated, the bottom surface of the central hull bottom portion **48** is formed of first and second central running surfaces, **43** and **45**, respectively, extending from the keel **36** as is commonly known. The first and second central running surfaces **43** and **45** are angled relative to horizontal at a deadrise angle, as is commonly known.

20 As best shown on Figures **5** and **6**, the first side hull has lower portion **13**, upper portion **17** and a first side hull actuating cavity **21** therebetween. Similarly, the second side hull has lower portion **15**, upper portion **19** and a second side hull actuating cavity **23** therebetween. The lower portions **13** and **15** of the first and  
25 second side hulls, **12** and **14**, respectively, are essentially oblique prisms in shape at the aft end of the vessel, although it may be appreciated that they may be another shape throughout the remainder of the length. The first side hull **12** lower portion **13** has outside surface **50**, first outside running surface **52**, inside lower side surface **54**, inside lower top surface **56**, inside upper side surface **58**  
30 and inside upper bottom surface **60**. The inside lower top surface **56** and inside upper side surface **58** form a cavity **66** sized to receive the central hull bottom portion **48** therein. The second side hull **14** lower portion **15** has outside surface **70**, second outside running surface **72**, inside lower side surface **74**, inside

5 lower top surface **76**, inside upper side surface **78** and inside upper bottom surface **80**. The inside lower top surface **76** and inside upper side surface **78** form a cavity **86** sized to receive the central hull bottom portion **48** therein. The first and second side hulls, **12** and **14**, are identical in shape, mirrored along centreline **200**.

10 In the first position, as shown on Figure **4**, the top of the bottom portion **48** of the central hull first and second side bottom portions, **42** and **44**, are arranged proximate to each other with the central hull bottom portion **48** nested within the cavities **66** and **86**, respectively. In this position, the marine vessel **10** has a narrow beam width **108**. The first position is beneficial for transporting the marine vessel **10** on a trailer outside of the water.

15 Turning to Figures **4**, **5** and **6**, the floor **102** is formed with the central hull top portion **46** and is positioned within the first and second side hull actuating cavities **21** and **23**. The floor **102** comprises a box shape with actuators enclosed therein lengthwise extending substantially from central hull keel front end **29** to floor rear end **106**, and having a width close to a narrow beam width **108** of the marine vessel **10**, extending from first side **24** to second side **26** as shown in the first position in Figure **4**. As best seen in Figures **2** and **3**, two front lateral actuators, first side front lateral actuator **90** and second side front lateral actuator **92** (not shown), are located at the front of the floor **102**, proximate to central hull keel front end **29**. Two rear lateral actuators, first side rear lateral actuator **94** and second side rear lateral actuator **96**, are located at the rear of the floor **102** proximate to the floor rear end **106**. The first side front and rear lateral actuators **90** and **94** are fixed at their first ends to the first side hull **12** and extend from first side **24** to a fixed upright wall **104** within the floor **102** at the centreline **200**, to which the second ends of the lateral actuators **90** and **94** are fixed. The second side front and rear lateral actuators **92** and **96** are fixed at their first ends to the second side hull **14** and extend from the second side **26** to a fixed upright wall **104** within the floor **102** at centreline **200**, to which the second ends of the lateral actuators **92** and **96** are fixed. The lateral actuators **90**, **92**, **94** and **96** may be selected to be linear actuators such as, by way of

-7-

non-limiting example, hydraulic, pneumatic or mechanical screw jack, although it will be appreciated that other actuator types may be useful, as well.

5 To convert from the first shallow hull position, as shown in Figure 4, to the second shallow hull position, as shown in Figure 5, the lateral actuators **90**, **92**, **94** and **96** are extended simultaneously. As the lateral actuators **90**, **92**, **94**, and **96** extend, the first and second side hulls **12** and **14** slide laterally outwards, increasing the beam width until it reaches a maximum beam width **110**. The floor **102** slides substantially out of the first and second side hull actuating cavities **21** and **23**, exposing most of the top of the floor surface. A small portion on each side of the floor remains within the actuating cavities, **21** and **23**, below the upper portions **17** and **19** of the first and second side hulls **12** and **14**.  
10

15 Figures **3** and **6** illustrate the third or deep vee hull configuration of the marine vessel **10**. As best seen in Figures **2** and **3**, a pivot hinge **112** pivotally connects the central hull top portion **46** to the bottom portion **48** at a location proximate to the central hull keel front end **29**. As illustrated in Figure **2**, a vertical actuator **98** extends from the compressed first position, and Figure **3** shows the vertical actuator **98** in the extended second position. The vertical actuator **98** is located proximate to the floor rear end **106** and the upper end is fixed to the floor **102** by any known means, such as, by way of non-limiting example, to a bracket attached by, such as, by way of non-limiting example, weld, bolts or rivets, although other attachment methods may be useful, as well. The lower end of the vertical actuator **98** is fixed to the central hull **16**. Although one vertical actuator **98** is illustrated in the present embodiment of the invention, it may be appreciated that additional vertical actuators may be useful, as well, so as to permit placement proximate to each side of the central hull bottom portion **48**.  
20  
25 The vertical actuator **98** may be such as, by way of non-limiting example, hydraulic, pneumatic or mechanical screw jack, but other actuator types may be useful, as well.  
30

To convert from the second shallow hull position, as illustrated in Figures **2** and **5**, to the third deep vee hull configuration, as illustrated in Figures **3** and **6**, the

-8-

vertical actuator **98** is extended, pivoting the central hull on the pivot hinge **112** and pushing the central hull keel **36** at the rear end of the central hull **16** proximate to the aft end **22** down past the first and second side hull keels **32** and **34**, such that the aft end **22** of the vessel forms a single deep vee configuration. The central hull bottom portion **48** and the first and second side hulls **24** and **26** may be slidably interlocked to each other by any commonly known means, such as, by way of non-limiting example, tongue and groove connector slides or the like. A cavity **99** is formed above the top of the central hull bottom portion **48** when the vessel is in the third deep vee configuration. The cavity **99** may be fitted with an expandable bladder as are commonly known which may be filled with water to weigh down the aft end of the vessel, increasing the aft depth and therefore producing a larger wake. In this configuration, the marine vessel **10** will produce a significant amount of wake, which is beneficial for high wake watersports, such as, by way of non-limiting example, wakeboarding or wake surfing.

Turning now to Figure **7**, a fourth or mid-level vee hull configuration is shown. This intermediate position between the second or wide beam shallow hull configuration and the third or wide beam deep vee hull configuration is achieved by extending the vertical actuator **98** only part way. This position maintains a generally trimaran hull shape with central hull keel **36** below the first and second side hull keels **32** and **34**, yet not as deep as in the third configuration, as shown in Figure **6**. In this configuration, the marine vessel **10** will produce a moderate amount of wake, while still able to achieve high speeds.

While specific embodiments of the invention have been described and illustrated, such embodiments should be considered illustrative of the invention only and not as limiting the invention as construed in accordance with the accompanying claims.

**The embodiments of the invention in which an exclusive property or privilege is claimed and defined as follows:**

1. A boat hull comprising:  
5  
a central hull having top and bottom portions; and  
first and second side hulls slidably supported from said top portion of  
said central hull so as to be transversely extendable relative thereto;  
10  
wherein  
said bottom portion of said central hull is rotatably connected to said top  
portion so as to be movable between raised and lowered positions, and  
wherein  
15  
said central hull and said first and second side hulls form a continuous  
wetted running surface thereunder.
2. The boat hull of claim 1 wherein said first and second side hulls are  
20  
positioned outside said bottom portion of said central hull at said lowered  
position.
3. The boat hull of claim 1 wherein said bottom portion of said central hull  
is nested within said first and second side hulls at said raised position.  
25
4. The boat hull of claim 1 further comprising at least one actuator for  
extending said first and second side hulls relative to said central hull.
5. The boat hull of claim 1 wherein said bottom portion of said central hull  
30  
is rotatable relative to said top portion about an axis.
6. The boat hull of claim 5 wherein said axis is horizontal.

7. The boat hull of claim **6** wherein said axis is located proximate to a leading edge of said bottom portion.

5 8. The boat hull of claim **1** wherein said bottom portion has an angular orientation relative to horizontal greater at said lowered position than at said raised position.

10 9. The boat hull of claim **1** further comprising an actuator for extending said bottom portion between said raised and lowered positions.

15 10. The boat hull of claim **1** wherein said bottom portion is abutable against and alignable with said first and second side hulls such that a bottom running surface of said bottom portion is continuous with corresponding bottom running surfaces of said side hulls at said lowered position.

20 11. The boat hull of claim **1** wherein said bottom portion of said central hull is positionable at an intermediate position between said raised and lowered positions.

25 12. The boat hull of claim **11** wherein said bottom portion is abutable against and alignable with said first and second side hulls at said intermediate position so as to form a continuous bottom running surface therebetween.

30 13. The boat hull of claim **1** further comprising a motor and drive assembly supported on said bottom portion of said central hull.

14. A method of reconfiguring a boat hull comprising:

providing a central hull having top and bottom portions;

35 providing first and second side hulls slidably supported from said top portion of said central hull so as to be transversely extendable relative thereto; wherein

said bottom portion of said central hull is rotatably connected to said top portion so as to be movable between raised and lowered positions, and wherein

5

said central hull and said first and second side hulls form a continuous wetted running surface thereunder.

**15.** A method of reconfiguring a boat hull comprising:

10

slidably displacing first and second side hulls relative to a central hull; and

15

rotatably displacing a bottom portion of said central hull relative to a top portion from a raised position to a lowered position between said first and second side hulls, wherein

20

said central hull and said first and second side hulls form a continuous wetted running surface thereunder.

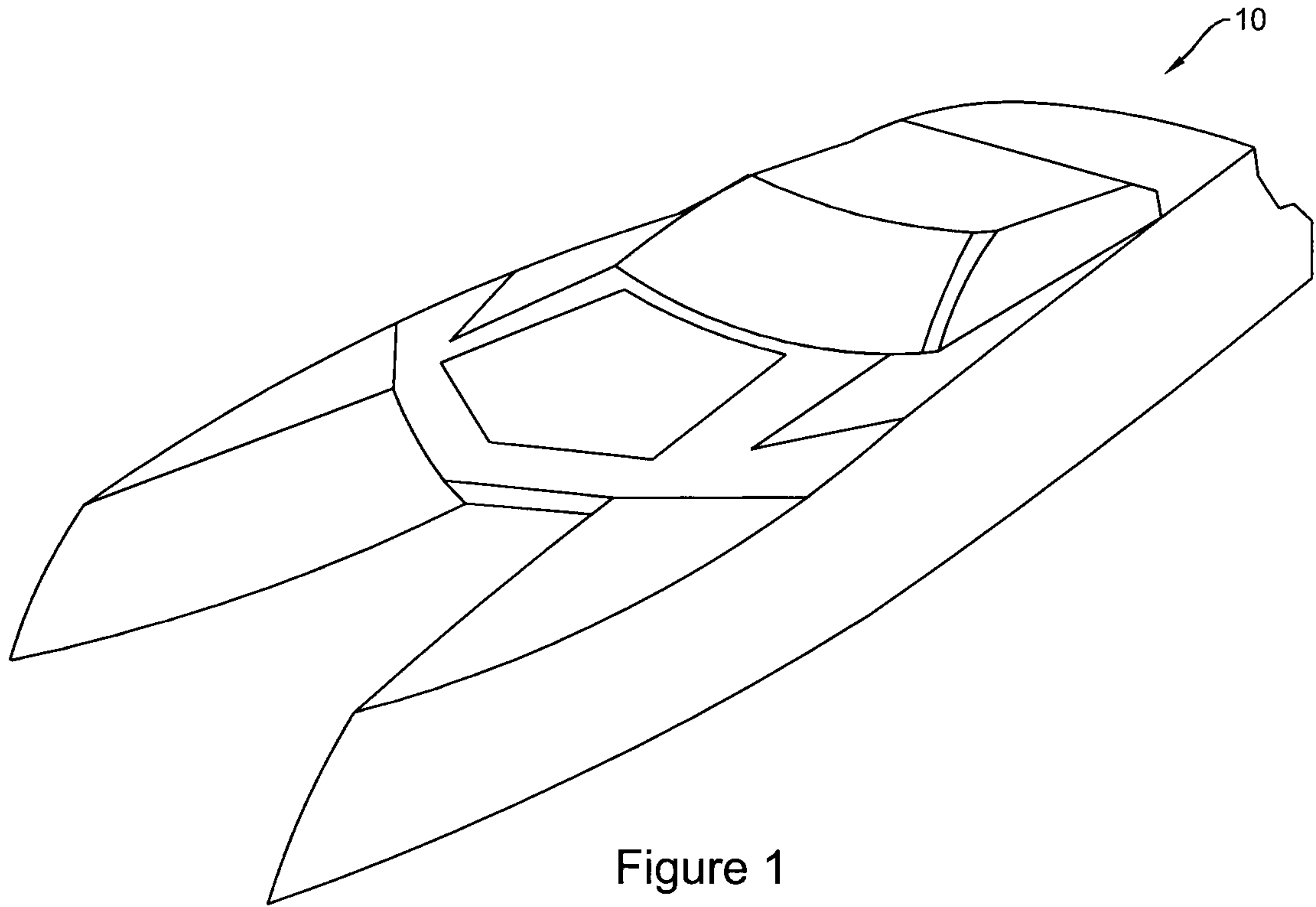

Figure 1

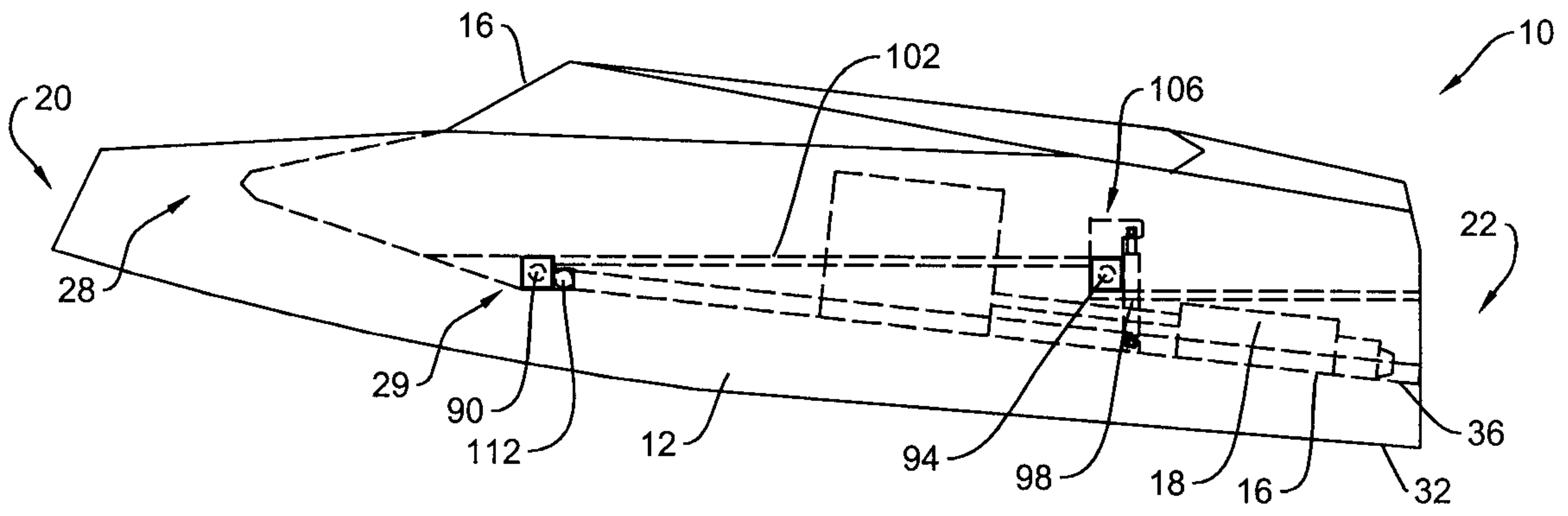

Figure 2

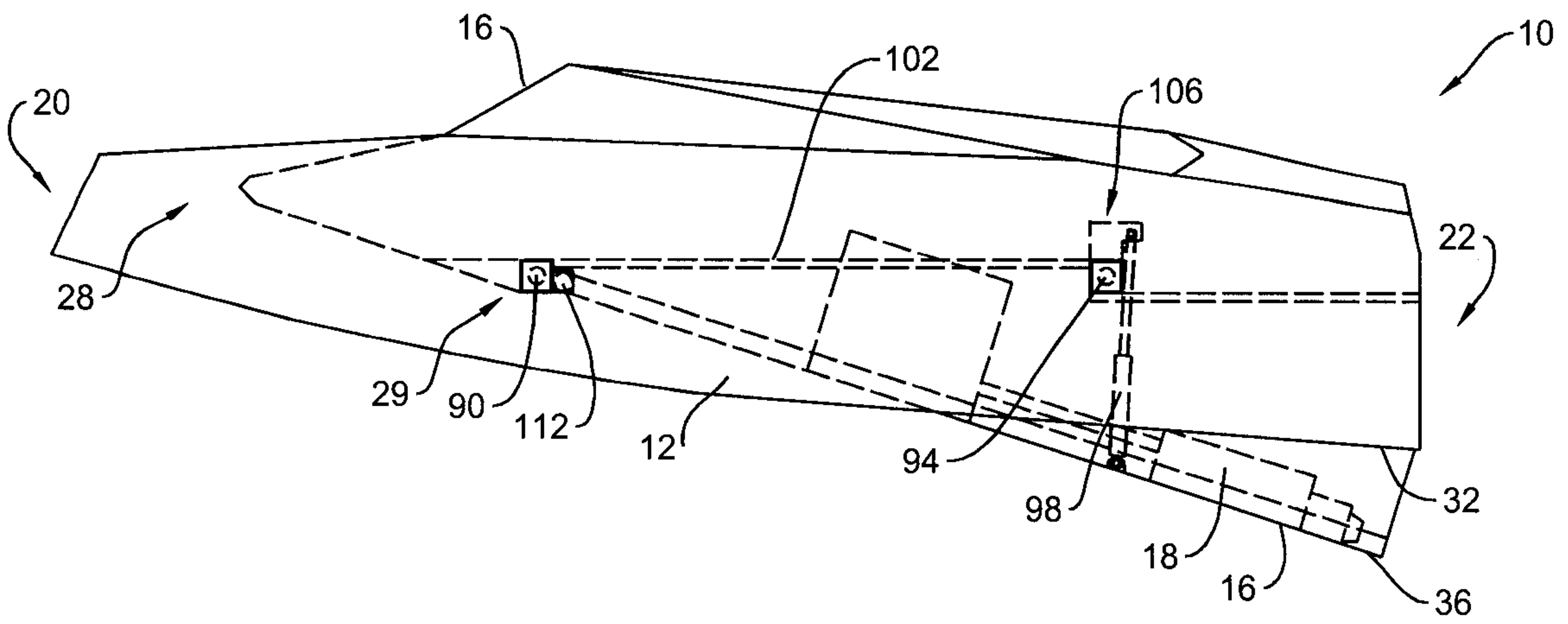

Figure 3

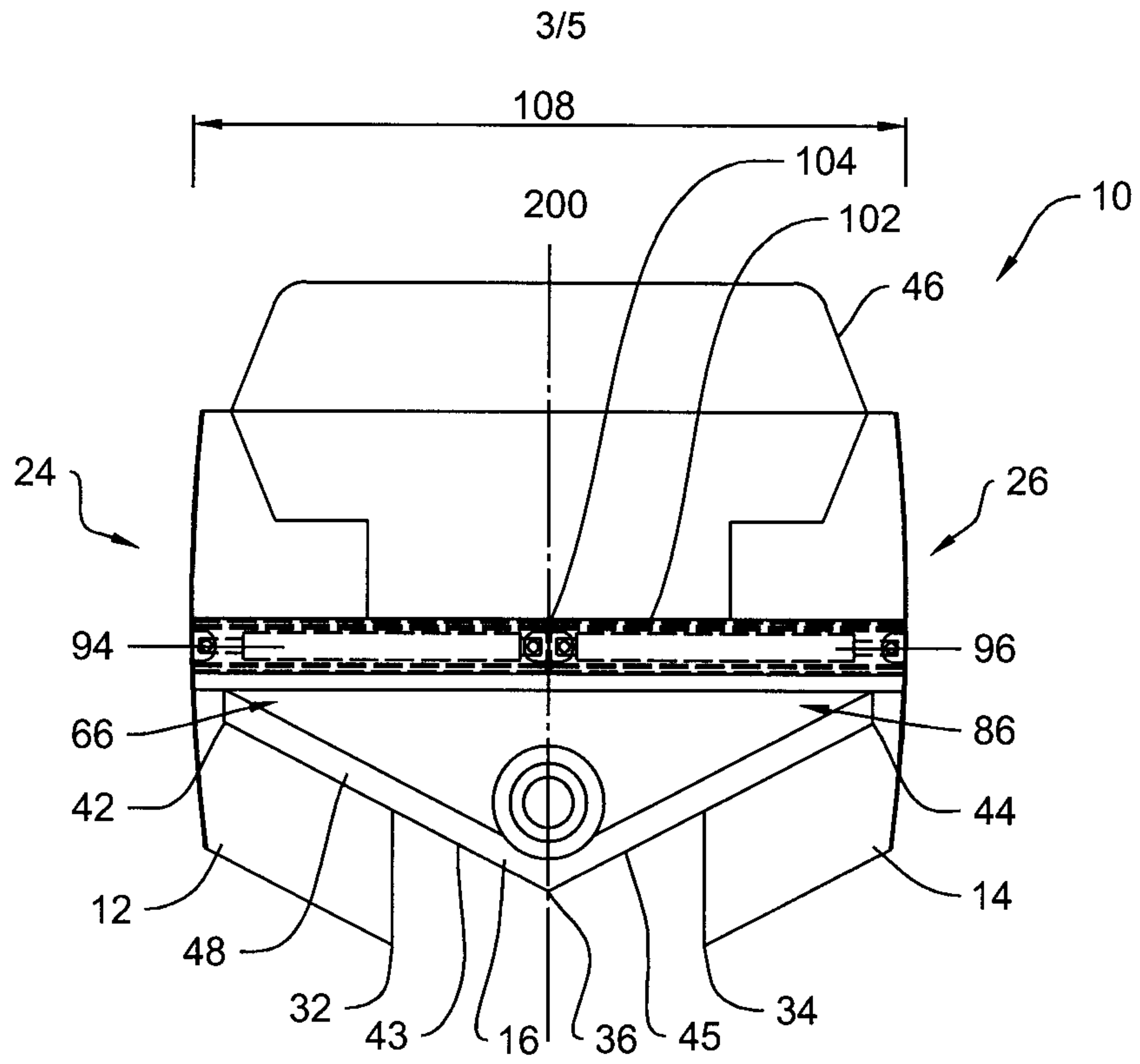

Figure 4

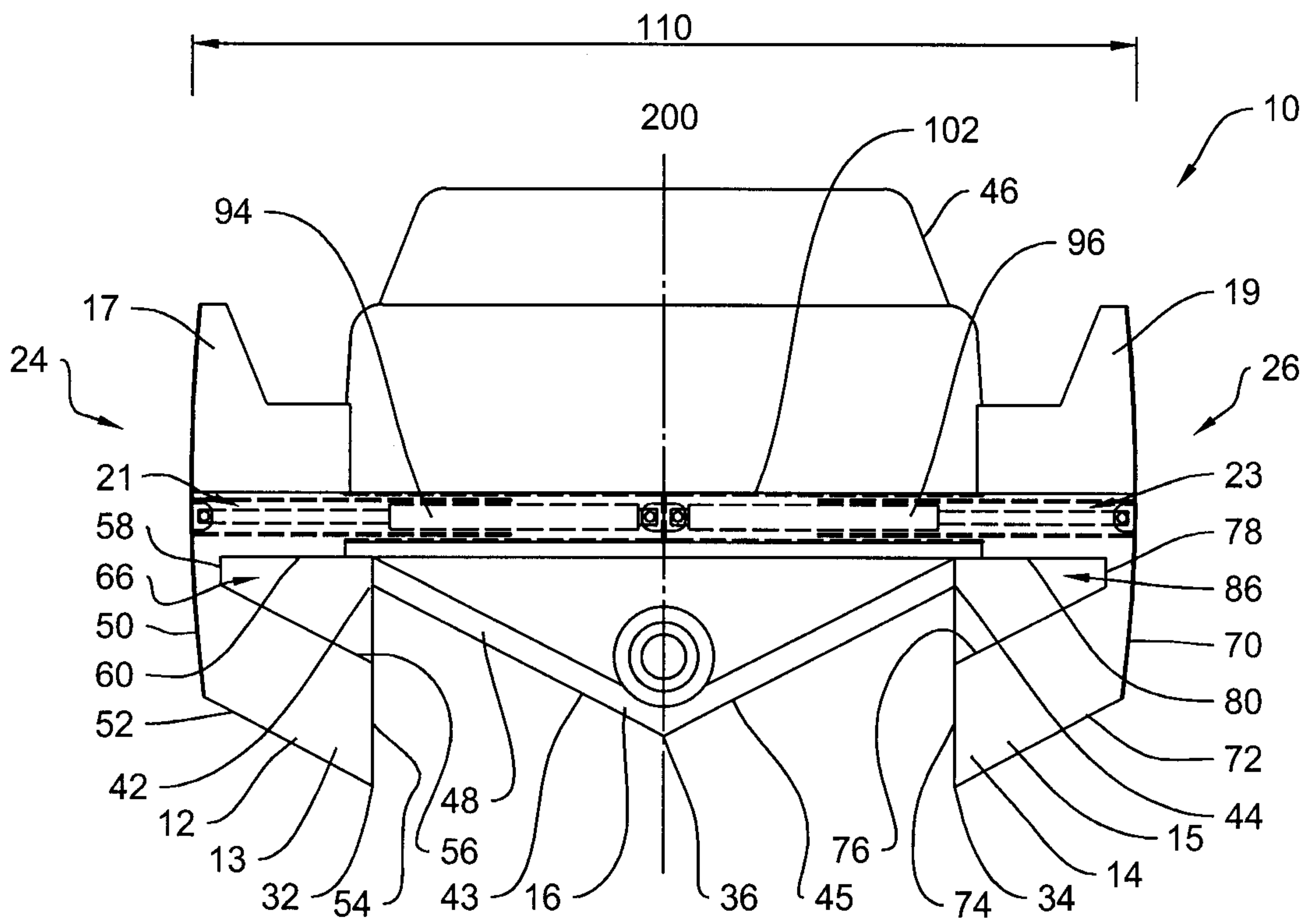

Figure 5



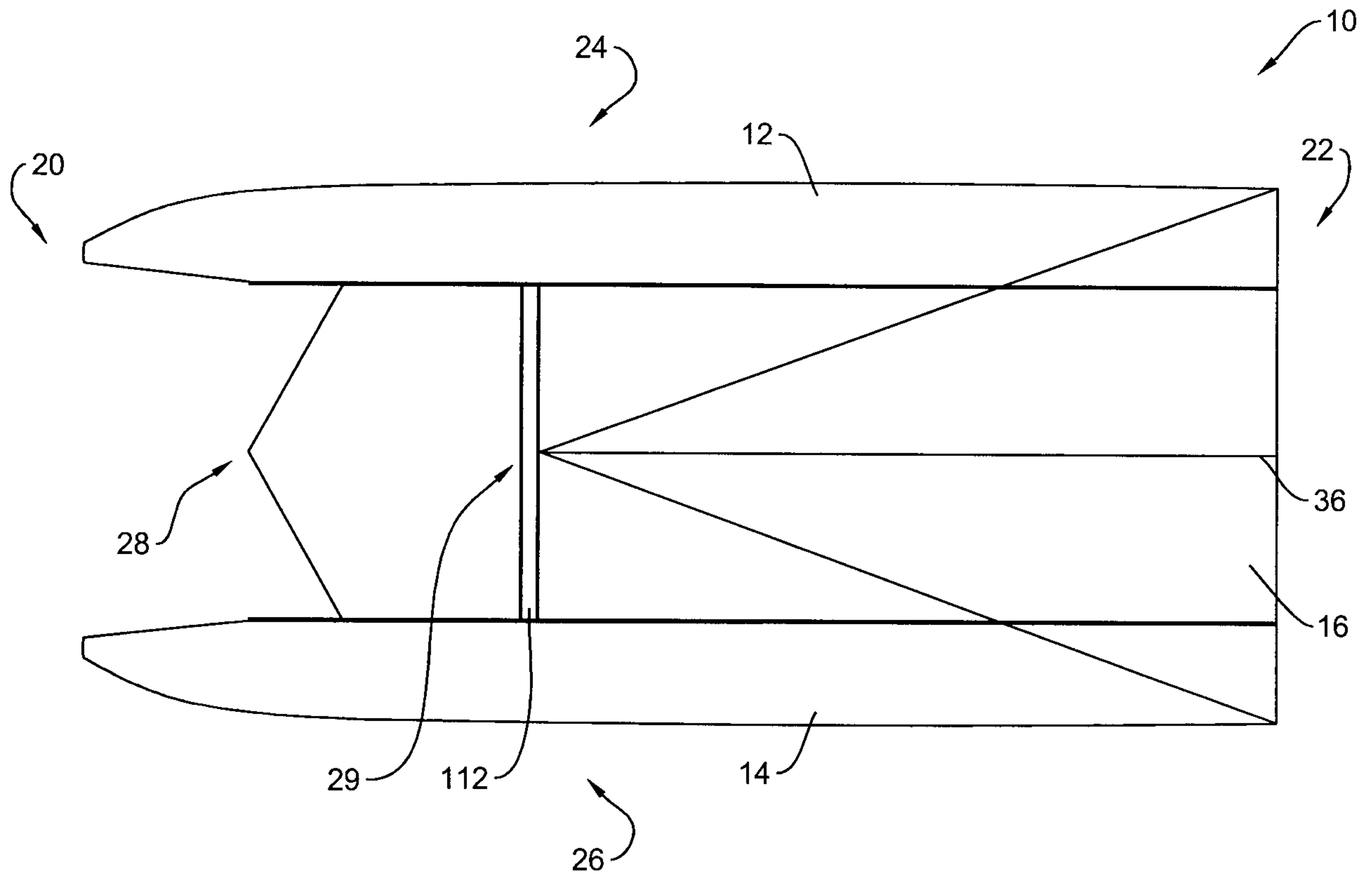

Figure 8

