



INTERNATIONAL APPLICATION PUBLISHED UNDER THE PATENT COOPERATION TREATY (PCT)

<p>(51) International Patent Classification⁵ : E05B 47/00</p>	<p>A1</p>	<p>(11) International Publication Number: WO 94/18423 (43) International Publication Date: 18 August 1994 (18.08.94)</p>
<p>(21) International Application Number: PCT/CA94/00092 (22) International Filing Date: 10 February 1994 (10.02.94) (30) Priority Data: 08/015,980 10 February 1993 (10.02.93) US (71) Applicant: ATOMA INTERNATIONAL, INC. [CA/CA]; P.O. Box 354, 521 Newpark Boulevard, Newmarket, Ontario L3Y 4X7 (CA). (72) Inventor: VERGIN, William, E.; 2553 Farmdale Drive, Sterling Heights, MO 48314 (US). (74) Agent: AITKEN, David, W.; Osler, Hoskin & Harcourt, Suite 1500, 50 O'Connor Street, Ottawa, Ontario K1P 6LZ (CA).</p>		<p>(81) Designated States: CA, JP, European patent (AT, BE, CH, DE, DK, ES, FR, GB, GR, IE, IT, LU, MC, NL, PT, SE). Published <i>With international search report.</i></p>

(54) Title: LINEAR MOTION DRIVE

(57) Abstract

A linear drive, particularly useful for locking or unlocking a door lock mechanism or the like permits manual operation by providing an output shaft that can move freely regardless whether the output shaft is in extended or retracted positions without back driving the motor. The output shaft is coaxially slideably situated over a worm gear shaft which moves a nut that is threadingly engaged therewith and moves inside the output shaft along the axial direction of the worm gear shaft. The output shaft is not threadingly engaged with the worm gear shaft. The output shaft thus is freely movable relative to the worm gear shaft, which results in essentially zero back drive of the worm gear shaft and the motor. To provide for manual operation, the nut is automatically moved back to its neutral position every time the output shaft is extended or retracted by a torsion spring or the like which can store energy therein. Whenever the motor is operated to drive the worm gear shaft, the spring gear is also rotated, which causes the spring to store energy therein. As soon as the motor is turned off, the energy stored in the spring causes the worm gear to rotate in the direction opposite to the last motor driven direction to move the nut to the neutral position it was in prior to energization of the motor.

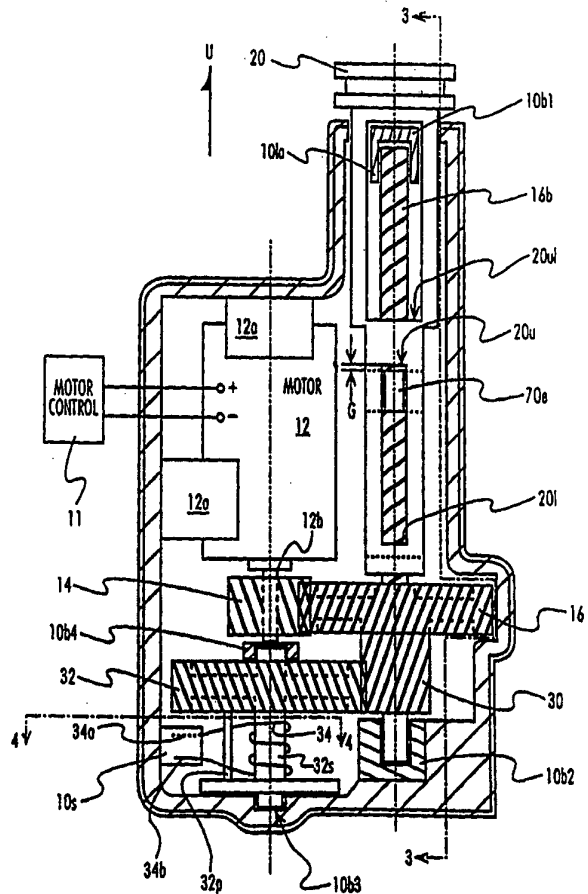

FOR THE PURPOSES OF INFORMATION ONLY

Codes used to identify States party to the PCT on the front pages of pamphlets publishing international applications under the PCT.

AT	Austria	GB	United Kingdom	MR	Mauritania
AU	Australia	GE	Georgia	MW	Malawi
BB	Barbados	GN	Guinea	NE	Niger
BE	Belgium	GR	Greece	NL	Netherlands
BF	Burkina Faso	HU	Hungary	NO	Norway
BG	Bulgaria	IE	Ireland	NZ	New Zealand
BJ	Benin	IT	Italy	PL	Poland
BR	Brazil	JP	Japan	PT	Portugal
BY	Belarus	KE	Kenya	RO	Romania
CA	Canada	KG	Kyrgystan	RU	Russian Federation
CF	Central African Republic	KP	Democratic People's Republic of Korea	SD	Sudan
CG	Congo	KR	Republic of Korea	SE	Sweden
CH	Switzerland	KZ	Kazakhstan	SI	Slovenia
CI	Côte d'Ivoire	LI	Liechtenstein	SK	Slovakia
CM	Cameroon	LK	Sri Lanka	SN	Senegal
CN	China	LU	Luxembourg	TD	Chad
CS	Czechoslovakia	LV	Latvia	TG	Togo
CZ	Czech Republic	MC	Monaco	TJ	Tajikistan
DE	Germany	MD	Republic of Moldova	TT	Trinidad and Tobago
DK	Denmark	MG	Madagascar	UA	Ukraine
ES	Spain	ML	Mali	US	United States of America
FI	Finland	MN	Mongolia	UZ	Uzbekistan
FR	France			VN	Viet Nam
GA	Gabon				

LINEAR MOTION DRIVE**BACKGROUND**

The present invention relates to a linear motion
5 drive, in particular for generating a linear motion from
a rotary motion while permitting independent manual
linear operation.

There are many uses for linear motion drive devices.
For instance, linear motion drive devices is particular
10 suitable for locking or unlocking a door locking
mechanism or the like. Power door locks, for example,
have been in use for locking and unlocking doors in
automobiles. There are many different types of actuators
for actuating a locking mechanism for doors or the like.

15 A typical power lock mechanism comprises an
electrical motor, and a rotary-to-linear transmission
mechanism which translates rotary motion from the motor
to a linear motion for actuating a door locking
mechanism. The rotary-to-linear mechanism typically
20 includes a reversibly rotatable lead-screw and a carriage
which linearly rides in the longitudinal direction of the
lead-screw as the lead-screw rotates or a rack and pinion
type where the motor drives a pinion (gear) and causes
the rack (carriage) to move linearly. The carriage or
25 rack is mechanically connected to the locking mechanism.

If the lead-screw/carriage or rack and pinion is
directly linked to the locking mechanism, manual
operation may be hindered or rendered difficult since the
motor has to be back driven. U.S. patent 4,723,454
30 issued to Periou et al, for instance, uses a carriage
which slides along the lead-screw to permit manual
operation. In particular, the lead-screw is permitted to
freely rotate in both directions when the motor is not
energized. The carriage is integral with a locking
35 mechanism attaching end. By manually pushing or pulling
the attaching end, the carriage can be moved linearly
relative to the lead-screw. A drawback of this type is
that manual operation causes back driving of the lead-

-2-

screw and the motor, which increases the manual force necessary to operate the locking mechanism. Moreover, because the carriage actually rides on the helical groove of the lead-screw, the carriage does not readily move in
5 the linear direction.

Many different devices have been contemplated in the past to prevent back driving of the motor and the lead-screws or the like during manual operation. U.S. Patents 4,290,634 issued to Gelhard; 4,821,521 to Schuler;
10 4,893,704 to Fry et al; 4,978,155 to Kobayashi, for instance, show various types of devices for preventing back driving of the motor during manual operation.

U.S. patent 4,978,155 uses a clutch mechanism between a drive shaft and an output shaft to transmit
15 power from the drive shaft to the output shaft. Specifically, the drive shaft is directly connected to the output of the motor and the output shaft is connected to a lock mechanism operating rod. The operating rod moves linearly about the longitudinal axis of the output
20 shaft via a helical thread formed on the output shaft. The clutch mechanism couples the drive shaft to the output shaft only when the motor is energized. At all other times, the output shaft freely rotates relative to the drive shaft. Similar to U.S. patent 4,723,454, the
25 operating rod may be manually depressed or extended, but such action causes the output shaft to rotate during manual operation, which increases the force necessary to move the operating rod. However, due to the clutch mechanism, the motor is not back driven in this type of
30 arrangement.

U.S. patent 4,893,704, on the other hand, uses complicated, coaxially arranged inner main and outer secondary shafts having opposed external threads that cooperate to send a drive member to a neutral position
35 without changing the direction of the motor during manual operation. Specifically, the drive member is connected to the outer secondary shaft via a lost motion device to

permit manual operation without back driving the motor. However, a drawback with this type of device is that the shaft needs to be further driven after the locking mechanism has been already actuated to position the drive member in a neutral position.

U.S. patent 4,290,634 shows a use of a flywheel that is connected to a motor to store energy which is used to actuate the door lock mechanism. When the lock operation is completed, the flywheel is uncoupled from the lock so that its residual energy is not absorbed by the lock to permit manual operation without turning the flywheel during manual operation. Specifically, one end of the rack has an abutment head which may be shifted into engagement with a C-shaped connector, which is connected to the lock mechanism and a manual operating knob, by suitably turning the pinion to drive the rack. A spiral spring is operatively connected to a shaft of the pinion to rotate the pinion using the energy stored in the spring to bring the abutment head in a neutral position to permit the manual knob to be depressed or extended without interference from the abutment head. In other words, a lost-motion type of connector is provided between the abutment head and the lock mechanism via the C-connector.

U.S. patent 4,821,521, similar to U.S patent 4,290,634, uses the energy stored in a coil or helical spring to bring the positioning element, which is connected to a locking mechanism, to an initial position when the motor is shut off. In this device, the positioning element is threadingly engaged with the gear spindle. The positioning element appears to be brought back to whatever position it was in prior to the actuation of the motor. It appears that there can be no manual operation with this type of actuator, or, at the very least, manual operation will be rather difficult since the positioning element is threadingly engaged to the gear spindle. Any type of manual operation

-4-

disadvantageously requires the spindle and thus the motor to be back driven.

SUMMARY OF THE INVENTION

5 Accordingly, the primary object of the present invention is to provide an improved mechanism for returning a rotary-to-linear mechanism to a neutral position without using a power drive.

10 Another object of the invention is to provide manual operation without back driving the motor or the transmission means.

Another object of the invention is to provide a power actuator for a door locking mechanism, which is free of the above-mentioned drawbacks.

15 Another object of the invention is to provide a simple and efficient manual and power operations.

20 These and other objects of the invention are achieved in the present invention by providing an output shaft that can move freely regardless of whether the output shaft is in extended or retracted positions, without back driving the motor or any of the driving elements. Specifically, the present invention provides an electrical motor with a gear, preferably helical for noise reduction purposes, which mates with preferably a worm gear. The worm gear is fixedly held collinearly with an elongated worm gear shaft. The worm gear shaft is mated with a worm nut which travels along the axis of the worm gear shaft as the worm gear rotates. The output shaft is coaxially situated over the worm gear with no thread engagement therebetween. The output shaft thus is freely movable relative to the worm gear shaft in the longitudinal or axial direction of the worm gear shaft, which results in essentially zero back drive of the worm gear shaft when manually moving the output shaft.

35 The output shaft and the nut are fixedly held from rotation so that rotation of the worm gear shaft causes the nut to move linearly along the axis of the worm gear

-5-

shaft, driving the output shaft linearly as the nut abuts against either of a pair of spaced apart abutments positioned within the output shaft. The two abutments are spaced along the axial direction of the output shaft.

5 When the motor rotates to cause the worm gear shaft to rotate in one direction so as to move the nut in the upward direction, the nut abuts against the upper abutment, causing the output shaft to move upward. When the motor rotates in the other direction so as to cause

10 the nut to move in the downward direction, the nut abuts against the lower abutment, causing the output shaft to move downward.

To provide for manual operation, the nut is brought to a neutral position without driving the motor every

15 time the output shaft is extended or retracted. This is achieved by providing a gear train engaging with the worm gear to drive a torsion spring or the like which can store energy therein. Specifically, in the present invention, the worm gear is collinearly arranged relative

20 to another gear which is operatively engaged with the a spring gear. The spring gear winds the torsion spring or the like whenever the motor is energized to rotate the worm gear. Whenever the motor is operated to drive the worm gear, the spring gear is also rotated, which causes

25 the spring to store energy therein. As soon as the motor is turned off, the energy stored in the spring causes the worm gear to rotate in the direction opposite to the last motor driven direction, which in turn brings the nut to the neutral position or the last position it was in prior

30 to the energization of the motor. In the neutral position, the nut is preferably positioned adjacent to the upper abutment, when the output shaft is in its lowermost or retracted position or adjacent to the lower abutment when the output shaft is in its uppermost or

35 extended position.

By positioning the nut in the neutral position which is adjacent to one of the abutments, manual operation can

-6-

be readily realized, without back driving the worm gear shaft nor the motor. The nut is preferably positioned adjacent to the output shaft's upper and lower abutments, in its neutral position, so that the nut can travel a
5 small distance to build a momentum prior to contacting one of the abutments. This provides for higher initial force for breaking through ice which may build up, for instance, if used in an automotive door lock system in the winter time, and for breaking through debris which
10 may build up over a period of use.

These and other objects of the invention will become more readily apparent in the ensuing specification when taken together with the drawings.

BRIEF DESCRIPTION OF THE DRAWINGS

15 Fig. 1 is a partially broken front elevational view of a preferred embodiment of the present invention with the output shaft in the retracted position and the nut in the neutral position.

Fig. 2 is similar to Fig. 1, but partially shown,
20 with the output shaft in the extended position and the nut in the neutral position.

Fig. 3 is a partially broken side elevational view taken along line 3-3 of Fig. 1

Fig. 4 is a cross-sectional view taken along line 4-
25 4 of Fig. 1.

Fig. 5 is a cross-sectional view taken along line 5-5 of Fig. 3 to show the arrangement between the nut and the output shaft more clearly.

DESCRIPTION OF THE PREFERRED EMBODIMENTS

30 The embodiments described herein have been contemplated for purposes of illustrating the principles of the present invention. Accordingly, the present invention is not to be limited solely to the exact configuration and construction illustrated and set forth
35 herein.

-7-

The use of directional description such as upward, upper, downward, and down, has been contemplated only for purposes of describing the drawing figures. Therefore, as the directional description is merely relative, depending upon how the actual present linear drive is positioned or mounted, the present invention is not to be confined to the directional description set forth herein.

Figs. 1 and 2 show the present invention with the output shaft 20 in the retracted and extended positions, respectively. Fig. 1 schematically shows the overall arrangement of the elements that make up the linear drive 1, with a portion of the housing 10 being shown removed or broken away and the output shaft 20 in the retracted position. Although not shown, it is to be noted that the housing 10 substantially encloses the entire linear drive. Fig. 2 is identical to Fig. 1, but only partially shows the linear drive, with the output shaft 20 in the extended position.

The linear drive 1 comprises an electrical motor 12 which is controlled by, for instance, a conventional motor control 11 driven by a D.C. power source, for instance, from the battery of an automobile. The motor 12 is stably held or attached to the housing 10 via conventional brackets or the like 12a. The motor control 11 controls the rotational direction of the motor and the time duration of the input voltage to the motor. Additionally, sensors and switches (not shown), which can be actuated by various moving elements of the linear drive such as the nut 70 and the output shaft 20, may be located inside the housing to control the motor. The motor 12 has at its shaft 12b, a gear 14 which is engaged with a drive gear 16. The drive gear in turn is fixedly and collinearly attached to or integrally formed with a worm gear shaft 16b. The worm gear shaft 16b in turn is threadingly engaged with the nut 70, which fixed from rotation, so that the rotation of the worm gear shaft 16b causes the nut to displace linearly along the axis of the

-8-

worm gear shaft 16b. It is to be noted that any type of gear can be contemplated in the present invention such as spur gears. However, it is preferable to use gears 14, 16, 30, 32 which are helical for purposes of noise reduction. The worm gear shaft 16b is journaled for rotation via bearing blocks or the like 10b formed with or attached to the housing 10.

Figs. 3 and 5 more clearly show the means for rotatably fixing the nut 70 relative to the output shaft 20 and the housing. Specifically, the nut 70 has a pair of diametrically opposed extensions 70e formed on the sides thereof, which extend through a pair of diametrically opposed slots 20s formed along the length of the output shaft 20 between a mid-upper abutment 20mu and a lower most abutment 20lm, and engage a pair of diametrically opposed grooves 10g formed on the housing 10. The groove/extension architecture permits the nut to substantially freely slide relative to the output shaft 20 and the housing 10 along the axial direction of the output shaft 20, but is prevented from rotating relative to the output shaft 20 and the housing 10. Moreover, the extension 70e of the nut 70 further prevents the output shaft 20 from rotating relative to the housing 10.

By rotating the worm gear shaft 16b, the nut 70 travels along the axis of the worm gear shaft 16b. The output shaft 20 is coaxially situated with the worm gear shaft 16b with no thread engagement therebetween to permit the output shaft 20 to freely move relative to the worm gear shaft 16b in the axial direction thereof. Openings 20o with a sufficient clearance to permit the worm gear shaft to rotate and the output shaft to move relative to the worm gear shaft 20, without interference are formed in the mid-upper abutment 20mu and the lower most abutment 20lm to permit the output shaft to freely move relative to the worm gear shaft 16b.

The drive gear 16 also is collinearly formed with or attached to an output gear 30. The end of the output

gear is rotatably journaled in a bearing block 10b2. The output gear 30 mates with a spring gear 32 which in turn is rotatably journaled for rotation in bearing blocks 10b3, 10b4. The spring gear 32 is fixedly attached to a
5 spring gear shaft 32s. A preloaded torsion or helical spring 34 is coaxially situated with the spring gear shaft 32s. A spring drive pin 34p extends parallel to the spring gear shaft 32s and attached to the spring gear and the cover 36. The spring gear 32, the spring pin 32p
10 and the cover 36 are fixed relative to each other so that they rotate in unison.

The arrangement of the spring 34 relative to the spring gear shaft 32s and the spring drive pin 32p is better shown in Figs. 1 and 4. The ends 34a, 34b of the
15 spring 34 extend generally laterally to the spring gear shaft 32s, with the spring gear pin 34p situated between the spring ends and a stop 10s formed inside the wall of the housing 10. The spring 34 is arranged such that rotation of the spring gear 32 and thus the spring gear
20 pin 32p in either direction by the motor causes the spring to wind. More specifically, as shown in Fig. 4, if the motor is driven to rotate the spring gear 32 in the clock-wise direction CW, the pin 32p engages the upper end 34a of the spring and rotates the same in the
25 clock-wise direction CW, driving the same away from the stop 10s, while the lower end 34b of the spring 34 is urged toward and abuts the stop 10s. This causes the spring 34 to wind and store energy therein. As soon as the motor is turned off, the spring 34 unwinds in the
30 counter clock-wise direction CCW, in the direction opposite to the last motor driven direction. That is, the upper end 34a of the spring engages the pin 32p and rotates the spring gear 32 in the counter clock-wise direction, thus driving the worm gear shaft 16b, which in
35 turn drives the nut 70 substantially back to the neutral position or the last position the nut was in prior to energization of the motor.

-10-

Similarly, if the motor is driven to rotate the spring gear in the counter clock-wise direction CCW, the pin 32p engages the lower end 34b of the spring and rotates the same in the counter clock-wise direction CCW, driving the same away from the stop 10s, while the upper end 34a of the spring 34 is urged toward and abuts the stop 10s. This causes the spring 34 to wind and store energy therein. As soon as the motor is turned off, the spring unwinds in the clock-wise direction CW, in the direction opposite to the last motor driven direction. That is, the lower end 34b of the spring engages the pin 32p and rotates the spring gear 32 in the clock-wise direction, thus driving the worm gear shaft 16b, which in turn drives the nut 70 substantially back to the neutral position or the last position the nut was in prior to energization of the motor.

The preloading of the spring 34 provides for a predetermined return force sufficient to overcome any frictional losses between the gears.

The output shaft 20 and the nut 70 are fixedly held from rotating via the groove/extension architecture, for example, so that rotation of the worm gear shaft 16b causes the nut to move linearly along the axis of the worm gear shaft, driving the output shaft 20 linearly when the nut 70 abuts against either of the spaced apart abutments 20u and 20l formed by the ends of the slots 20s.

As shown in Fig. 1, the output shaft 20 is in the retracted position, at which the output shaft 20 is positioned such that the top portion 70t of the nut is adjacent to the upper abutment 20u. In operation, when the motor 12 is energized to rotate the worm gear shaft 16b to move the nut 70 in the upward direction U, the top portion 70t of the nut 70 abuts against the upper abutment 20u and drives the output shaft upward to the extended position as shown in Fig. 2, until the upper-lower abutment 20ul of the output shaft 20 abuts against

-11-

or is immediately adjacent to the lower abutment 101a formed by the bearing block 10b1.

When the motor stops, the stored energy from the spring 34 rotates the worm gear shaft 16b in the direction opposite to the last motor driven direction, moving the nut 70 in the downward direction D, and bringing the nut 70 to its neutral position as shown in Fig. 2, all without moving the output shaft 20 since the nut 70 is slidably moveable relative to the output shaft 20. The lower portion 70b of the nut 70 is preferably adjacent the lower abutment 201 at its neutral position. At this point, the output shaft 20 can be manually moved in the downward direction D to the retracted position and moved back to the extended position with essentially zero backdriving of the worm gear shaft 16b and the motor.

When the output shaft is in the extended position as shown in Fig. 2, as previously discussed, the lower portion 701 of the nut 70 abuts or is preferably adjacent the lower abutment 201 of the output shaft 20. A slight gap G between the nut and the upper and lower abutments 20u and 20l which are generally caused by hysteresis in the gears and variations in component dimensions is present. However, this gap is preferable since it permits the motor/worm/nut to build momentum prior to contacting the output shaft, which provides for higher initial force for breaking through any ice and debris. The output shaft 20 is moved until the upper-upper abutment 20uu of the output shaft abuts against or is immediately adjacent to the upper abutment 10ua of the bearing block 10b1. Again, when the motor stops, the stored energy from the spring 34 rotates the worm gear shaft 16b in the direction opposite to the last motor driven direction, moving the nut 70 in the upward direction U, and bringing the nut to its neutral position as shown in Fig. 1, all without moving the output shaft 20 since the nut 70 is slidably moveable relative to the output shaft 20. At this point, the output shaft 20 can

-12-

be manually moved in the upward direction U to the extended position and moved back to the retracted position with essentially zero backdriving of the motor and the worm gear shaft 16b.

5 Sensors or switches (not shown) may be used to stop the motor at the appropriate sensed positions. For instance, sensors may be placed along the length of the output shaft to detect the position of the output shaft and cause the motor to stop when the output shaft is at
10 the extended position or retracted position. The particular arrangement of sensors and switches to control the motor is believed to be well known to one versed in the art, and thus need not be disclosed herein. U.S. patents 4,135,377 issued to Kleefeldt, et al. and U.S.
15 patent 4,893,704, for instance, disclose sensors and switches for controlling a motor.

Given the disclosure of the present invention, one versed in the art would readily appreciate the fact that there can be many modifications of the present invention
20 not specifically depicted and described, but that are well within the scope and spirit of the disclosure set forth herein. Accordingly, all expedient modifications readily attainable by one versed in the art from the disclosure set forth herein that are within the scope and
25 essence of the present invention, are to be included as further embodiments of the present invention.

-13-

What is claimed is:

1. A linear drive which permits manual locking and unlocking operation, comprising:

a housing;

an electric motor mounted in said housing;

a gear shaft rotatably mounted in said housing and operatively engaged with said electric motor for rotation thereof;

a hollow output shaft coaxially and collinearly situated over said gear shaft and freely movable relative to said gear shaft in an axial direction of said gear shaft to an extended position and to a retracted position, said output shaft having an upper abutment and a lower abutment that are spaced apart in said axial direction;

a nut threadingly engaged with said gear shaft and located between said abutments;

means for permitting movement of said nut relative to said output shaft in the axial direction of said gear shaft between said abutments without moving said output shaft,

wherein said nut engages with said upper abutment to move said output shaft upward to said extended position upon energization of said motor in one direction and engages with said lower abutment to move said output shaft downward to said retracted position upon energization of said motor in a direction opposite to said one direction; and

means for automatically moving said nut to its neutral position, without energizing said motor, after when said motor is energized to cause said nut to move said output shaft to said extended and retracted positions, said neutral position being at which said nut is adjacent said lower abutment when said output shaft is in said extended position and being at which said nut is adjacent said upper abutment when said output shaft is in said retracted position,

-14-

wherein by virtue of said neutral position of said nut being situated adjacent said upper abutment of said output shaft when said output shaft is in said retracted position, said output shaft is manually and repeatedly movable to said extended position and back to said retracted position without back driving said gear shaft and said motor and by virtue of said neutral position of said nut being situated adjacent said lower abutment when said output shaft is in said extended position, said output shaft is manually and repeatedly movable to said retracted position and back to said extended position without back driving said gear shaft and said motor.

2. A linear drive according to claim 1, wherein said automatic nut moving means comprises a helical or torsion spring which is energized by the rotational movement of said gear shaft, said spring releasing the stored energy when said motor is deenergized or stopped to cause said gear shaft to rotate in the opposite direction to the last motor driven direction.

3. A linear drive according to claim 2, wherein said gear shaft is a worm gear shaft.

4. A linear drive according to claim 3, wherein said automatic nut moving means comprises a spring gear fixedly and coaxially attached to a spring gear shaft which is journaled for a rotational movement, said spring being coaxially situated over said spring gear shaft, said spring gear being driven by said worm gear shaft.

5. A linear drive according to claim 4, further comprising a worm gear collinearly attached to said worm

-15-

gear shaft, and an output gear attached to an output of said motor which mates with said worm gear.

6. A linear drive according to claim 5, further comprising a spring drive gear collinearly attached to said worm gear and mating with said spring gear.

7. A linear drive according to claim 4, wherein one end of said spring is attached to said spring gear shaft and the other end is attached to a stop formed on a wall of said housing, wherein rotation of said spring gear strains said spring to store energy therein.

8. A linear drive according to claim 5, wherein one end of said spring is attached to said spring gear shaft and the other end is attached to a stop formed on a wall of said housing, wherein rotation of said spring gear strains said spring to store energy therein.

9. A linear drive according to claim 6, wherein one end of said spring is attached to said spring gear shaft and the other end is attached to a stop formed on a wall of said housing, wherein rotation of said spring gear strains said spring to store energy therein.

10. A linear drive according to claim 1, wherein said upper and lower abutments each have an opening with sufficient clearance to permit said worm gear shaft to freely pass therethrough and rotate without interference therefrom, wherein the distance between said upper and lower abutments being equal to or less than the distance of travel of said output shaft between said extended position and said retracted position.

11. A linear drive according to claim 10, wherein said means for permitting movement of said nut comprises a pair of opposed slots formed inside a predetermined

-16-

length of said output shaft between said upper and lower abutments and a corresponding pair of opposing extensions formed on said nut to slidably ride on said slots; and a pair of opposed parallel grooves formed on inside walls of said housing and running parallel to said slots and engaging said extensions so as to prevent said nut and said output shaft from rotating.

12. A linear drive according to claim 1, wherein said further the neutral position remains substantially at constant.

13. In a linear drive for actuating a door locking mechanism which permits manual locking and unlocking operation, wherein an electric motor drives an output shaft, which is operatively linked to cause locking and unlocking of said lock mechanism, between an extended position and a retracted position, relative to a housing which substantially encloses elements of said linear drive, said linear drive comprising:

a gear shaft rotatably mounted in said housing and operatively engaged with said electric motor for rotation thereof;

a hollow output shaft coaxially and collinearly situated over said gear shaft and freely movable relative to said gear shaft to said extended and retracted positions in an axial direction of said gear shaft, said output shaft having an upper abutment and a lower abutment that are spaced apart in said axial direction;

a nut threadingly engaged with said gear shaft and located between said abutments;

means for permitting movement of said nut relative to said output shaft in the axial direction of said gear shaft between said abutments without moving said output shaft,

wherein said nut engages with said upper abutment to move said output shaft upward to said extended position

-17-

upon energization of said motor in one direction and engages with said lower abutment to move said output shaft downward to said retracted position upon energization of said motor in a direction opposite to said one direction; and

means for automatically moving said nut to its neutral position, without energizing said motor, after when said motor is energized to cause said nut to move said output shaft to said extended and retracted positions, said neutral position being at which said nut is adjacent said lower abutment when said output shaft is in said extended position and being at which said nut is adjacent said upper abutment when said output shaft is in said retracted position,

wherein said output shaft is mechanically linked to said door locking mechanism to permit locking and unlocking the same, wherein by virtue of said nut being situated adjacent said upper abutment when said output shaft is in said retracted position, said output shaft is manually and repeatedly movable to said extended position and back to said retracted position without back driving said gear shaft and said motor and by virtue of said nut being situated adjacent said lower abutment when said output shaft is in said extended position, said output shaft is manually and repeatedly movable to said retracted position and back to said extended position without back driving said gear shaft and said motor.

14. A linear drive for a door locking mechanism according to claim 13, wherein said gear shaft is a worm gear shaft.

15. A linear drive for a door locking mechanism according to claim 14, wherein said automatic nut moving means comprises a helical or torsion spring which is

-18-

energized by the rotational movement of said worm gear shaft, said spring releasing the stored energy when said motor is deenergized or stopped to cause said gear shaft to rotate in the opposite direction to the last motor driven direction.

16. A linear drive for a door locking mechanism according to claim 15, wherein said automatic nut moving means comprises a spring gear fixedly and coaxially attached to a spring gear shaft which is journaled for a rotational movement, said spring being coaxially situated over said spring gear shaft, said spring gear being driven by said worm gear shaft.

17. A linear drive for a door locking mechanism according to claim 16, further comprising a worm gear collinearly attached to said worm gear shaft, and an output gear attached to an output of said motor which mates with said worm gear.

18. A linear drive for a door locking mechanism according to claim 17, further comprising a spring drive gear collinearly attached to said worm gear and mating with said spring gear.

19. A linear drive for a door locking mechanism according to claim 15, wherein one end of said spring is attached to said spring gear shaft and the other end is attached to a stop formed on a wall of said housing, wherein rotation of said spring gear strains said spring to store energy therein.

20. A linear drive for a door locking mechanism according to claim 16, wherein one end of said spring is attached to said spring gear shaft and the other end is attached to a stop formed on a wall of said housing,

-19-

wherein rotation of said spring gear strains said spring to store energy therein.

21. A linear drive for a door locking mechanism according to claim 17, wherein one end of said spring is attached to said spring gear shaft and the other end is attached to a stop formed on a wall of said housing, wherein rotation of said spring gear strains said spring to store energy therein.

22. A linear drive for a door locking mechanism according to claim 14, wherein said upper and lower abutments each have an opening with sufficient clearance to permit said worm gear shaft to freely pass therethrough and rotate without interference therefrom, wherein the distance between said upper and lower abutments being substantially equal to or less than the distance of travel of said output shaft between said extended position and said retracted position.

23. A linear drive for a door locking mechanism according to claim 22, wherein said means for permitting movement of said nut comprises a pair of opposed slots formed inside a predetermined length of said output shaft between said upper and lower abutments and a corresponding pair of opposing extensions formed on said nut to slidingly ride on said slots; and a pair of opposed parallel grooves formed on inside walls of said housing and running parallel to said slots and engaging said extensions so as to prevent said nut and said output shaft from rotating.

1 / 5

Fig. 1

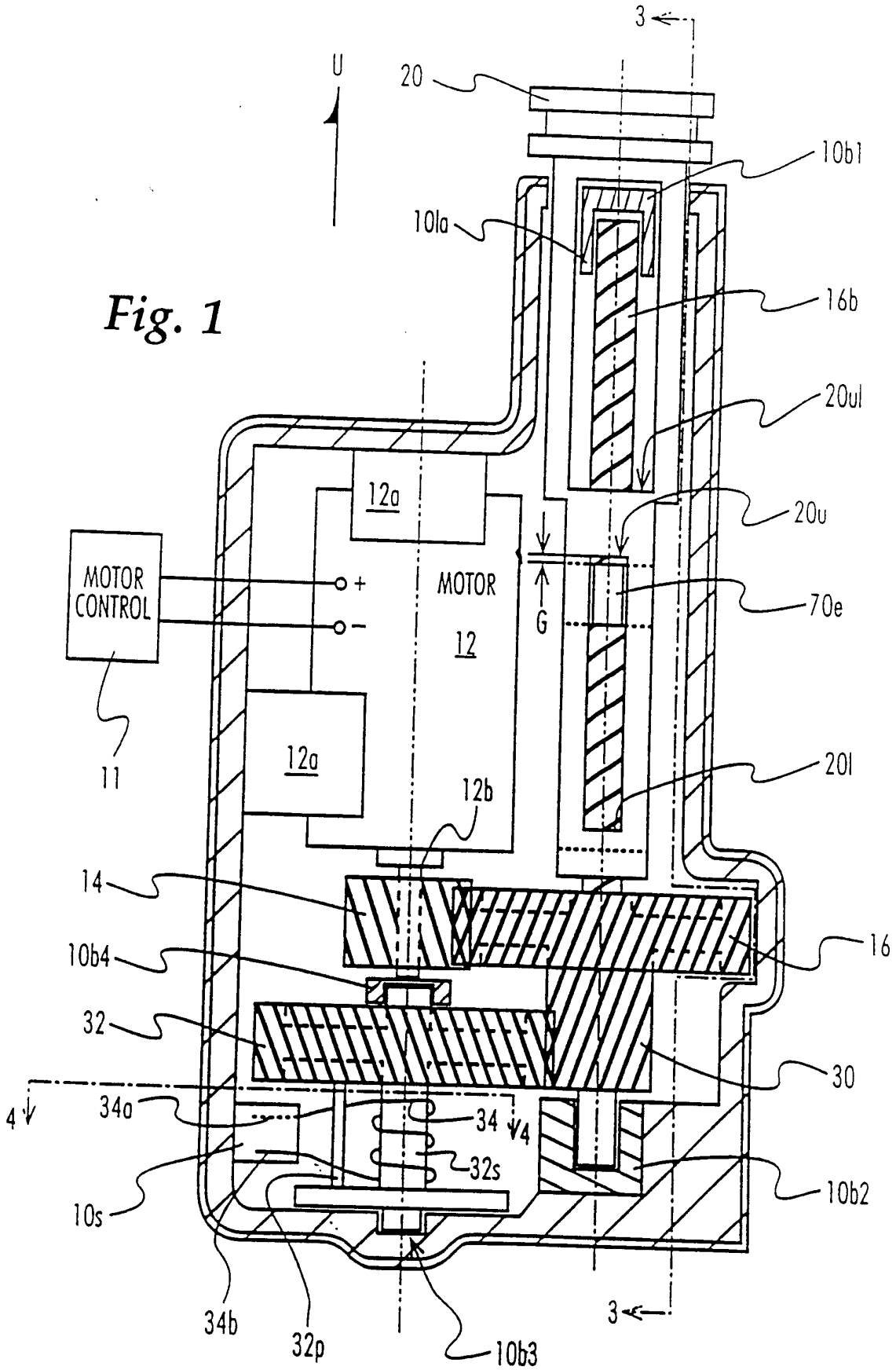

2 / 5

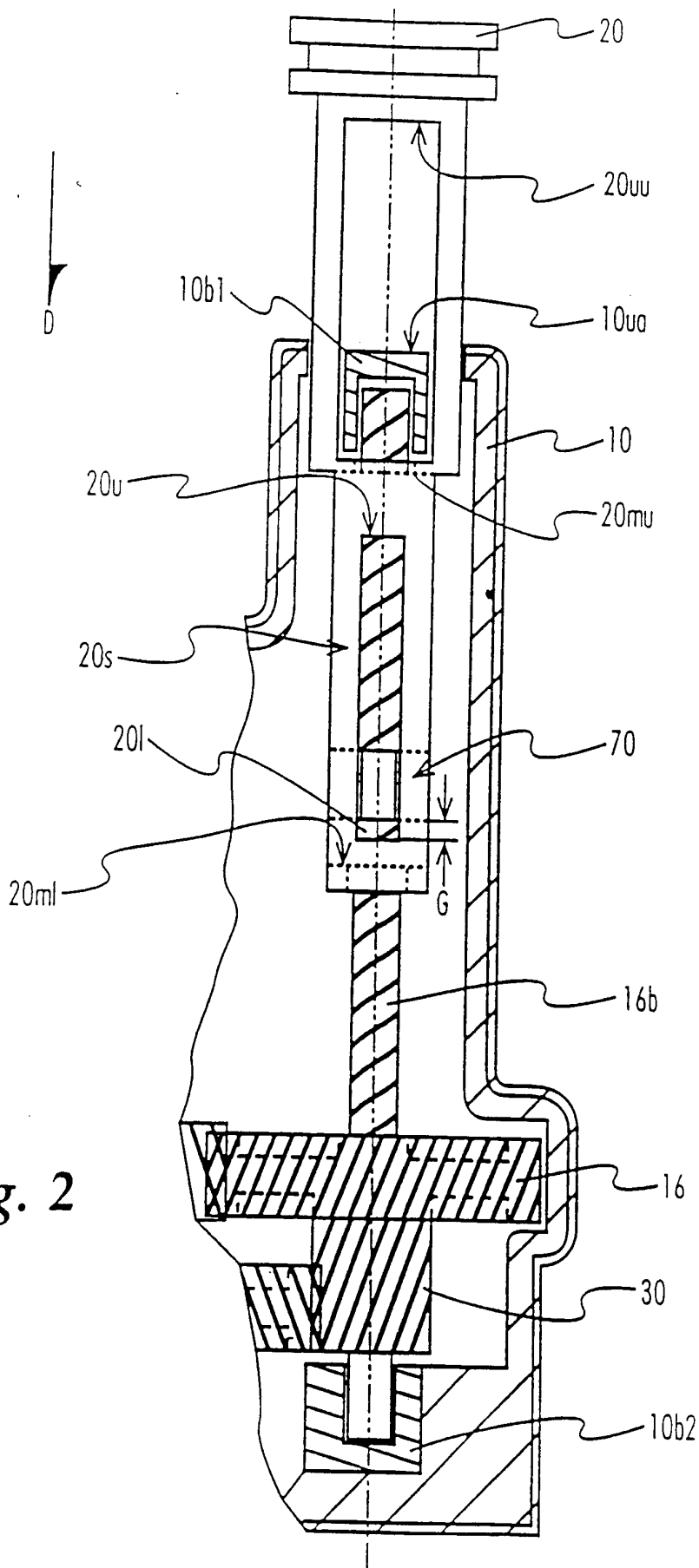

Fig. 2

3 / 5

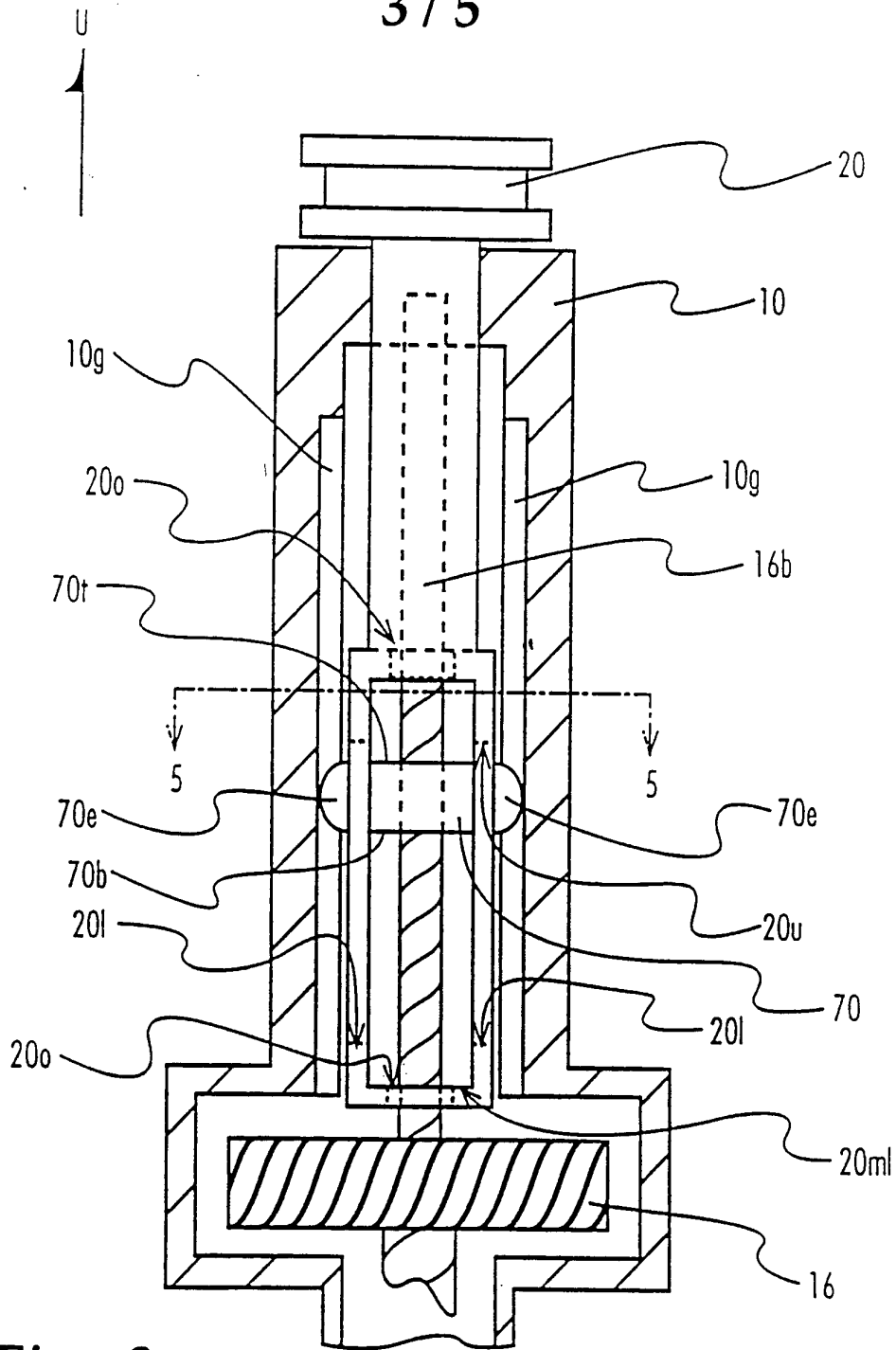

Fig. 3

4 / 5

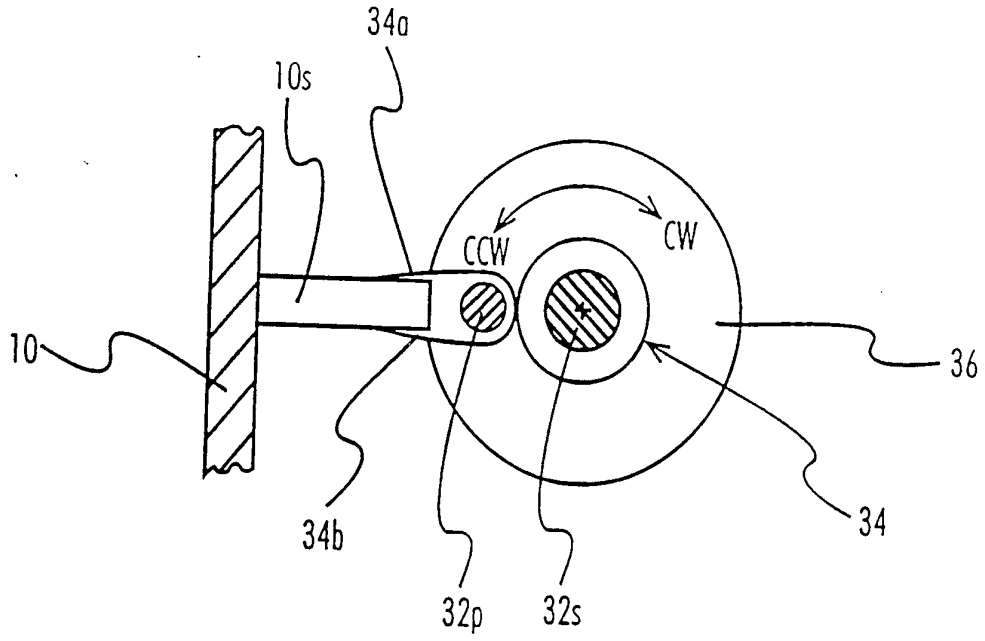

Fig. 4

5 / 5

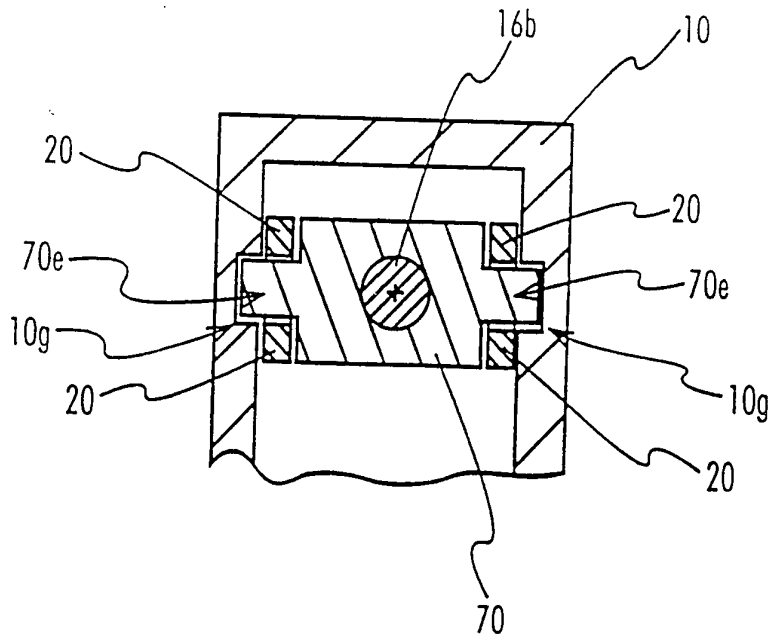

Fig. 5

INTERNATIONAL SEARCH REPORT

Intern al Application No

PCT/CA 94/00092

A. CLASSIFICATION OF SUBJECT MATTER

IPC 5 E05B47/00

According to International Patent Classification (IPC) or to both national classification and IPC

B. FIELDS SEARCHED

Minimum documentation searched (classification system followed by classification symbols)

IPC 5 E05B

Documentation searched other than minimum documentation to the extent that such documents are included in the fields searched

Electronic data base consulted during the international search (name of data base and, where practical, search terms used)

C. DOCUMENTS CONSIDERED TO BE RELEVANT

Category *	Citation of document, with indication, where appropriate, of the relevant passages	Relevant to claim No.
X	FR,A,2 596 096 (VACHETTE) 25 September 1987 see page 5, line 1 - page 7, line 4 see page 8, line 11 - page 10, line 18 ---	1-3, 10-15, 22,23
X	US,A,5 079 964 (HAMADA) 14 January 1992 see the whole document ---	1-3, 12-15
A	US,A,4 821 521 (SCHULER) 18 April 1989 cited in the application see the whole document -----	1

Further documents are listed in the continuation of box C.

Patent family members are listed in annex.

* Special categories of cited documents :

- "A" document defining the general state of the art which is not considered to be of particular relevance
- "E" earlier document but published on or after the international filing date
- "L" document which may throw doubts on priority claim(s) or which is cited to establish the publication date of another citation or other special reason (as specified)
- "O" document referring to an oral disclosure, use, exhibition or other means
- "P" document published prior to the international filing date but later than the priority date claimed

- "T" later document published after the international filing date or priority date and not in conflict with the application but cited to understand the principle or theory underlying the invention
- "X" document of particular relevance; the claimed invention cannot be considered novel or cannot be considered to involve an inventive step when the document is taken alone
- "Y" document of particular relevance; the claimed invention cannot be considered to involve an inventive step when the document is combined with one or more other such documents, such combination being obvious to a person skilled in the art.
- "&" document member of the same patent family

Date of the actual completion of the international search

17 May 1994

Date of mailing of the international search report

02 -06- 1994

Name and mailing address of the ISA

European Patent Office, P.B. 5818 Patentlaan 2
NL - 2280 HV Rijswijk
Tel. (+ 31-70) 340-2040, Tx. 31 651 epo nl,
Fax: (+ 31-70) 340-3016

Authorized officer

Verelst, P

INTERNATIONAL SEARCH REPORT

Information on patent family members

International Application No

PCT/CA 94/00092

Patent document cited in search report	Publication date	Patent family member(s)	Publication date
FR-A-2596096	25-09-87	NONE	
US-A-5079964	14-01-92	JP-A- 2311682	27-12-90
		JP-A- 3151480	27-06-91
		CA-A- 2017363	25-11-90
US-A-4821521	18-04-89	DE-U- 8621592	09-10-86
		FR-A- 2602816	19-02-88
		GB-A, B 2193748	17-02-88
		SE-B- 462628	30-07-90
		SE-A- 8701948	13-02-88