

Jan. 29, 1963

P. C. CULVER ET AL

3,075,310

SELECTIVE BLEND INDICATOR

Filed Dec. 12, 1960

2 Sheets-Sheet 1

Fig. 1.

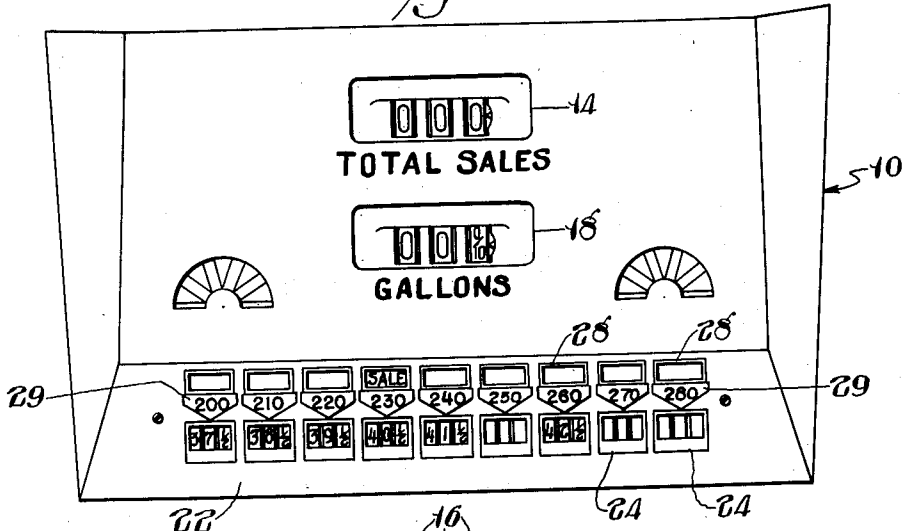
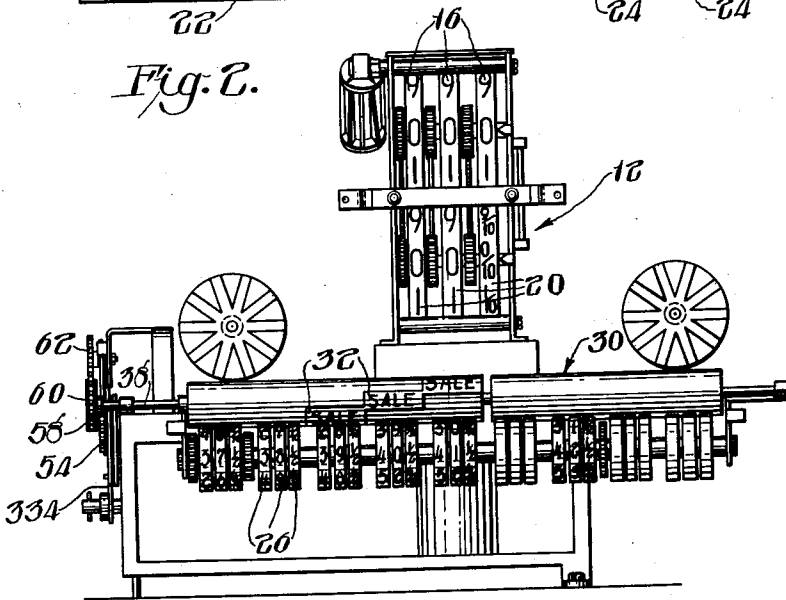

Fig. 2.



Jan. 29, 1963

P. C. CULVER ET AL  
SELECTIVE BLEND INDICATOR

3,075,310

Filed Dec. 12, 1960

2 Sheets-Sheet 2

Fig. 3.

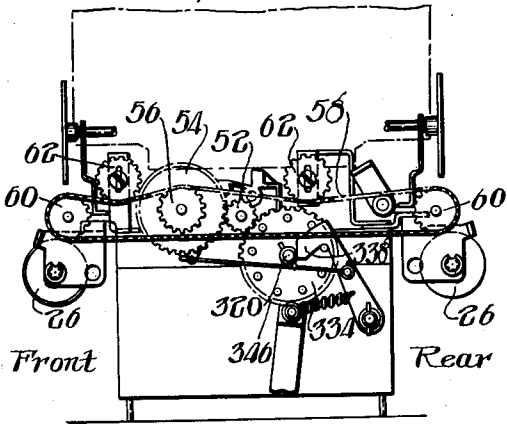

Fig. 4.

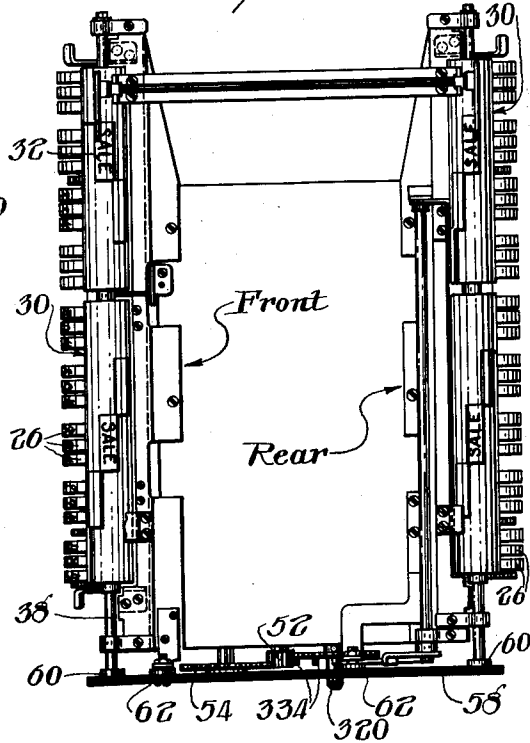

Fig. 6.

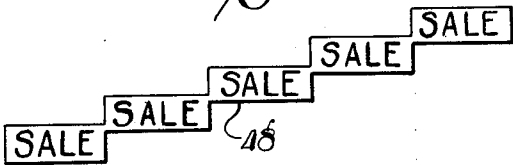
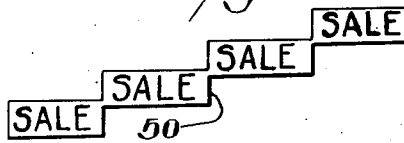

Fig. 7.



1

3,075,310

**SELECTIVE BLEND INDICATOR**

Paul C. Culver and Edward L. Copony, Salisbury, Md.,  
assignors to Symington Wayne Corporation, Salisbury,  
Md., a corporation of Maryland  
Filed Dec. 12, 1960, Ser. No. 75,229  
5 Claims. (Cl. 40-68)

This invention relates to a selective blend indicator for a multiblend dispensing gasoline pump, and it more particularly relates to such an indicator which designates the blend which has been selected and its price.

A pump for dispensing selected blends of two different grades of gasoline is described in U.S. Patent 2,880,908. The pump described in this patent dispenses nine different blends, and the price for each of these blends is displayed to the operator and the purchaser through a series of windows in the dial plate of the pump. FIG. 7 of that patent also describes a movable mask which is selectively aligned with these windows and includes a portion extending into the selected window for indicating the price of the grade or blend of gasoline selected for delivery. It is also suggested therein that an arrow be printed upon the extending portion of the mask to clearly indicate to the purchaser the blend being dispensed and its price. This mask is attached to a cord extending over pulleys which is operated from a drum which is adjusted to different angular orientations in synchronism with a shaft in the blend varying apparatus of the dispenser. With a pulley and cable driven device of this sort, the movable mask is likely to slip in operation which would most undesirably cause errors in blend indication and price indication; also, and more important, is the fact that the cable is subject to wear and breakage resulting in costly maintenance expense.

An object of this invention is to provide a simple, economical, and more dependable indicator for designating the blend selected for dispensing from a multiblend gasoline pump; and

Another object is to provide such an indicator which is associated with the price indicating apparatus for such a pump.

In accordance with this invention a selective blend indicator for a multiblend dispensing gasoline pump includes drums or rollers mounted in back of the front and rear dial plate of the pump and parallel to the row of windows in which the prices of the available blends are displayed. A row of ports is also arranged in the dial plate in front of the drum and adjacent the row of price indicating windows with each one of the ports being immediately adjacent each of the price windows, for example, above them. A nonslip transmission means connects the drum to a shaft of the dispenser whose angular orientation varies as each blend is selected, and discrete indicia are mounted upon the surface of the drum in line with each port. Each of these discrete indicia is angularly staggered over the drum to cause them to come separately into view in the ports for indicating that the blend whose price is displayed in the window disposed immediately adjacent the port showing the indicia has been selected for dispensing.

Novel features and advantages of the present invention will become apparent to one skilled in the art from a reading of the following description in conjunction with the accompanying drawings wherein similar reference characters refer to similar parts and in which:

FIG. 1 is a rear view in elevation of the dial plate of a gasoline dispenser which incorporates an embodiment of this invention;

FIG. 2 is a rear view in elevation of the quantity and

2

price computing mechanism behind the dial plate shown in FIG. 1;

FIG. 3 is a side view in elevation of the computing mechanism shown in FIG. 2;

FIG. 4 is a plan view of the portion shown in FIG. 3;

FIG. 5 is a rear view in elevation partially broken away in cross section of the indicating drum shown in FIGS. 2-4; and

FIGS. 6 and 7 are developed layout patterns of the indicia mounted upon the rear drum shown in FIG. 5.

In FIG. 1 is shown the dial plate 10 of a gasoline dispenser, not fully shown, which is mounted over a computing mechanism 12 of the type described in U.S. Patent 2,880,908 which selectively dispenses various blends of two different grades of gasoline. As shown in FIGS. 1 and 2, upper central window 14 displays the total price of each sale as indicated by total price drums 16, and lower central window 18 displays the total gallonage of each sale as indicated by total gallonage indicating drums or wheels 20. Dial plate 10 also includes a blend and price indicating panel 22 including a row of windows 24 in which the prices of all available blends are indicated by price indicating drums 26. A row of ports 28 are also arranged upon blend price indicating panel 22 with each of these ports being disposed intimately adjacent each of windows 24, for example, above them. Blend indicia 29 are positioned between each pair of adjacent price windows 24 and ports 28 for identifying the blend which is selected for dispensing. An indicating drum or roller 30 is rotatably mounted in back of the dial plate parallel to windows 24 and back of ports 28 for indicating the blend selected for dispensing and its price.

Roller 30 accordingly includes discrete indicia 32 which, for example, are labels bearing the word "Sale" in line with each of ports 28. These indicia are angularly staggered over roller 30 to cause them to come separately into view in ports 28 for indicating the price of the blend being dispensed by displaying the word "Sale" in the port disposed intimately above the price of that blend. In FIG. 1 the word "Sale" is accordingly displayed above the "40½" cent per gallon price to indicate to the operator and purchaser that the blend corresponding to this price has been selected for dispensing. In the dispenser herein described, nine different blends are available for dispensing; and rotatable drum 30 is accordingly adjustable to nine different angular orientations corresponding to each of these blends. The "Sale" indicia are accordingly positioned at equal angular intervals of forty degrees about the circumference of the roller.

FIGS. 5 and 6-7 show the manner in which drum or roller 30 is conveniently fabricated. FIG. 5 illustrates that drum 30 includes two cylinders 34 and 36 which are mounted side-by-side upon a common shaft 38. Cylinders 34 and 36 and inserted end plates 40 are conveniently made of aluminum or plastic. The closed ends 42 of cylinders 34 and 36 include hubs 44 within which set screws or pins 46 securely fasten cylinders 34 and 36 to shaft 38.

FIG. 6 is a layout pattern 48 for the five "Sale" indicia on cylinder 34 on the rear side of the device. This layout pattern provides forty degree intervals between the center of each "Sale" indicia when applied upon the surface of cylinder 34, for example, by a lithographing process. FIG. 7 is the layout pattern for the four "Sale" indicia upon cylinder 36 which also provides forty degree intervals when applied over the surface of cylinder 36, for example, by the same type of lithographing process. "Sale" indicia on cylinders 34 and 36 on the front side

of the device are staggered in reverse to the layouts in FIGS. 5, 6 and 7.

FIGS. 2, 3 and 4 show the manner in which drum 30 is rotated in accordance with the angular positions of a shaft 320 of a dispenser of the type shown in U.S. Patent 2,880,908 whose angular orientation varies as each of nine different blends are selected. Shaft 320 and other numbers in the "300" series are portions of the mechanism illustrated in FIG. 11 of the U.S. Patent 2,880,908 and also described in column 9, lines 70-75 and column 10, lines 1-13 of that patent. Gear teeth 346 upon disc 334 are engaged by a transfer pinion 52 with a gear 54 rotatably mounted parallel to sprocket 56 secured upon a common shaft with gear 54 to accordingly rotate it in accordance with the angular orientation of shaft 320. A sprocket chain 58 connects a pair of sprockets 60 secured to the ends of shaft 38 of front and rear drums 30 for positively rotating drums 30 to angular orientations in accordance with the angular orientations of shaft 320 of the blend selecting portion of the dispenser. A pair of idler sprockets 62 are engaged with sprocket chain 58 to maintain it tightly engaged with drive sprocket 56 and driven sprockets 60 to prevent any slippage or tooth jumping which would destroy the angular synchronism of drum 30 with blend selecting shaft 320.

As shaft 320 rotates when each of nine different blends are selected, drum 30 rotates the indicia "Sale" into the port 28 disposed intimately next to the window 24 which shows the price of the blend selected. The positive drive of the sprocket chain transmission prevents any slippage between the parts of the mechanism and minimizes any frictional resistance thereby providing a highly dependable and maintenance free means for indicating which blend is being dispensed from the multiblend dispenser.

What is claimed is:

1. A selective blend indicator for a multiblend dispensing gasoline pump having a shaft whose angular

orientation varies as each blend is selected and a row of windows in a substantially straight line in a dial plate which display the prices of the available blends, said indicator comprising a drum, rotatable means mounting said drum in back of said dial plate parallel to said windows, a row of ports disposed in a substantially straight line in said dial plate in front of said drum and adjacent and substantially parallel to said row of windows, one of said ports being disposed immediately adjacent each of said windows, nonslip transmission means connecting said drum to said shaft for rotating it to angular positions in accordance with the blend selected, discrete indicia mounted upon the surface of said drum in line with each of said ports, and said discrete indicia being angularly staggered over said drum to cause them to come separately into view in said ports for indicating that the blend whose price is displayed in said window disposed immediately adjacent the indicia-displaying port has been selected for dispensing.

2. A selective blend indicator as set forth in claim 1 wherein said nonslip transmission means comprises a sprocket chain drive.

3. A selective blend indicator as set forth in claim 1 wherein said drum comprises a pair of cylinders mounted end-to-end upon a common shaft.

4. A selective blend indicator as set forth in claim 1 wherein said row of ports are disposed above said row of windows.

5. A selective blend indicator as set forth in claim 4 wherein designations of the character of said blends are arranged between each of said windows and associated port.

#### References Cited in the file of this patent

#### UNITED STATES PATENTS

1,749,562	Carroll	Mar. 4, 1930
2,880,908	Young	Apr. 7, 1959