



(51) International Patent Classification:

B66B 7/12 (2006.01) *G01N 27/82* (2006.01)
G01J 5/10 (2006.01)

(21) International Application Number:

PCT/FI2019/050587

(22) International Filing Date:

16 August 2019 (16.08.2019)

(25) Filing Language:

English

(26) Publication Language:

English

(71) Applicant: **KONE CORPORATION** [FI/FI]; Kartanontie 1, 00330 Helsinki (FI).

(72) Inventors: **VALJUS, Petteri**; c/o Kone Corporation, Kartanontie 1, 00330 Helsinki (FI). **KINNARI, Jouko**; c/o Kone Corporation, Kartanontie 1, 00330 Helsinki (FI). **HYYPIÖ, Risto**; c/o Kone Corporation, Kartanontie 1, 00330 Helsinki (FI). **SUOPAJÄRVI, Pekka**; c/o Kone Corporation, Kartanontie 1, 00330 Helsinki (FI). **SIPO-**

LA, Teemu; c/o Kone Corporation, Kartanontie 1, 00330 Helsinki (FI).

(74) Agent: **BERGGREN OY**; P.O. Box 16, (Eteläinen Rautatiekatu 10 A), 00330 Helsinki (FI).

(81) Designated States (unless otherwise indicated, for every kind of national protection available): AE, AG, AL, AM, AO, AT, AU, AZ, BA, BB, BG, BH, BN, BR, BW, BY, BZ, CA, CH, CL, CN, CO, CR, CU, CZ, DE, DJ, DK, DM, DO, DZ, EC, EE, EG, ES, FI, GB, GD, GE, GH, GM, GT, HN, HR, HU, ID, IL, IN, IR, IS, JO, JP, KE, KG, KH, KN, KP, KR, KW, KZ, LA, LC, LK, LR, LS, LU, LY, MA, MD, ME, MG, MK, MN, MW, MX, MY, MZ, NA, NG, NI, NO, NZ, OM, PA, PE, PG, PH, PL, PT, QA, RO, RS, RU, RW, SA, SC, SD, SE, SG, SK, SL, SM, ST, SV, SY, TH, TJ, TM, TN, TR, TT, TZ, UA, UG, US, UZ, VC, VN, ZA, ZM, ZW.

(84) Designated States (unless otherwise indicated, for every kind of regional protection available): ARIPO (BW, GH, GM, KE, LR, LS, MW, MZ, NA, RW, SD, SL, ST, SZ, TZ, UG, ZM, ZW), Eurasian (AM, AZ, BY, KG, KZ, RU, TJ,

(54) Title: ELEVATOR ROPE MONITORING DEVICE, A METHOD AND A COMPUTER PROGRAM PRODUCT THERETO, AND AN ELEVATOR SYSTEM

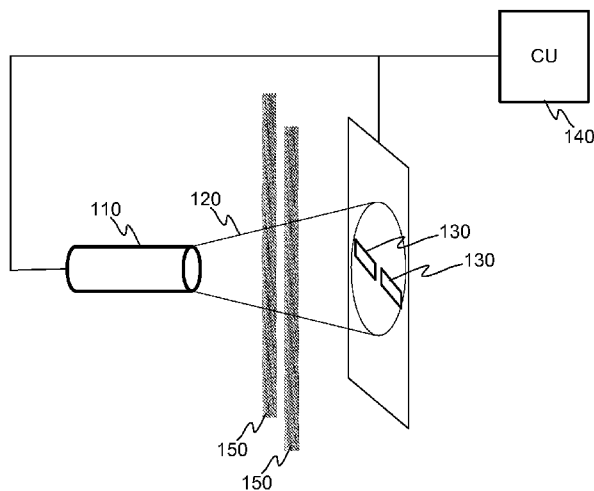

FIGURE 1

(57) Abstract: The present invention relates to an elevator rope monitoring device comprising: at least one source of electromagnetic radiation (110) for emitting a radiation beam, at least one sensor (120) for receiving at least part of an emitted radiation beam, a control unit for detecting an abnormality of an elevator rope (150) arranged to travel between the at least one source of electromagnetic radiation (110) and the at least one sensor (120) by analyzing measurement data received from the at least one sensor (120). The invention also relates to a method, to a computer program product and an elevator system.



TM), European (AL, AT, BE, BG, CH, CY, CZ, DE, DK, EE, ES, FI, FR, GB, GR, HR, HU, IE, IS, IT, LT, LU, LV, MC, MK, MT, NL, NO, PL, PT, RO, RS, SE, SI, SK, SM, TR), OAPI (BF, BJ, CF, CG, CI, CM, GA, GN, GQ, GW, KM, ML, MR, NE, SN, TD, TG).

Published:

— *with international search report (Art. 21(3))*

ELEVATOR ROPE MONITORING DEVICE, A METHOD AND A COMPUTER PROGRAM PRODUCT THERETO, AND AN ELEVATOR SYSTEM

TECHNICAL FIELD

- 5 The invention concerns in general the technical field of elevators. More particularly, the invention concerns rope monitoring solution for elevator systems.

BACKGROUND

10 Elevator safety is one of the most important matters to ensure. The elevator systems comprise ropes, such as suspension ropes, compensation ropes and over-speed governor ropes, which are wearing parts having an estimated life-time and for this reason a condition of the ropes needs to be monitored for ensuring safe use of the elevator system and life-time predictability in question.

15 Typically, the ropes used in the elevator solutions now-a-days are stranded steel wire ropes. The ropes may be affected by corrosion, chemical attack as well as mechanical attack which all may cause damages to the ropes. The challenge in traditional ways of monitoring the condition of the elevator ropes is to decide so-called discard criteria for replacing a damaged rope with a new one. Especially, the decision-making, and especially an evaluation of the rope condition, has
20 been time-consuming and inaccurate with the traditional methods, because it is based on a visible detection of diameter reduction and broken wires within the rope. Additionally, a tolerance for rope permanent elongation may be monitored.

In a document WO 2018/101296 A1 it is described a solution for monitoring an elevator rope. The solution is based on using a plurality of cameras for imaging
25 an entire circumference of a traveling elevator rope and the images taken with the cameras are brought to image processing means for detecting an abnormality in the elevator rope by analyzing the entire circumferential image created from a plurality of images taken with the plurality of cameras. The

solution also comprises speed/position detecting device for providing information to be associated with the images in order to combine the plurality of images in an appropriate manner. However, the solution as introduced in the document is problematic in a sense that it is slow to use since combining the
5 images and analyzing the combined image is time consuming as well as costly due to complex structure of the solution.

Hence, there is need to introduce alternative solutions which mitigate at least in part drawbacks of the existing solutions and allow condition monitoring of elevator ropes in an efficient manner.

10 SUMMARY

The following presents a simplified summary in order to provide basic understanding of some aspects of various invention embodiments. The summary is not an extensive overview of the invention. It is neither intended to identify key or critical elements of the invention nor to delineate the scope of the
15 invention. The following summary merely presents some concepts of the invention in a simplified form as a prelude to a more detailed description of exemplifying embodiments of the invention.

An object of the invention is to present an elevator rope monitoring device, a method, a computer program product and a system for monitoring an elevator
20 rope.

The objects of the invention are reached by an elevator rope monitoring device, a method, a computer program product and a system for monitoring an elevator rope as defined by the respective independent claims.

According to a first aspect, an elevator rope monitoring device is provided, the
25 elevator rope monitoring device comprising: at least one source of electromagnetic radiation for emitting a radiation beam; at least one sensor for receiving at least part of an emitted radiation beam; a control unit for detecting an abnormality of an elevator rope arranged to travel between the at least one

source of electromagnetic radiation and the at least one sensor by analyzing measurement data received from the at least one sensor.

For example, the at least one source of electromagnetic radiation may comprise at least one lens for collimating the radiation.

- 5 The at least one source of electromagnetic radiation and the at least one lens may be mutually positioned so that the at least one source of electromagnetic radiation is positioned into a focal point of the at least one lens.

The at least one source of electromagnetic radiation may further comprise at least one radiation aperture for blocking at least a portion of the radiation for
10 generating a linear radiation beam.

Further, the at least one source of electromagnetic radiation may further comprise a radiation window for emitting the radiation beam towards the at least one sensor from the at least one source of electromagnetic radiation.

The at least one source of electromagnetic radiation may also comprise a
15 controllable protection cover for protecting the radiation window from dirt, the controllable protection cover is arranged on a surface of the radiation window facing the at least one sensor.

Alternatively or in addition, the at least one source of electromagnetic radiation may comprise a protection cover arranged on a surface of the radiation window
20 facing the at least one sensor, the protection cover is implemented with a number of detachable plastic protecting films stacked on top of each other on the radiation window.

Moreover, the at least one sensor may be a linear photosensitive array detector.

Still further, the control unit may be arranged to perform an analysis by:
25 generating a representation of the elevator rope as a function of a lengthwise position of the elevator rope.

The control unit may also be arranged to detect deviation between the data received from the at least one sensor and a comparison data in the analysis. The comparison data may e.g. comprise at least one of the following: a comparison value for a width of the elevator rope; a comparison value for a data representing an edge of the elevator rope; a comparison value for a data representing a loose strand of the elevator rope; a comparison value for a data representing a wire-cut of the elevator rope (150).

Generally speaking, the at least one source of electromagnetic radiation may be arranged to generate a laser light. The at least one source of electromagnetic radiation may e.g. comprise at least one laser diode for generating the laser light.

According to a second aspect, a method for monitoring an elevator rope is provided, the method comprising: generating, by a control unit of an elevator rope monitoring device, a control signal to at least one source of electromagnetic radiation for emitting a radiation beam; receiving, by the control unit of the elevator rope monitoring device, a measurement data from at least one sensor receiving at least part of an emitted radiation beam; detecting, by the control unit of the elevator rope monitoring device, an abnormality of an elevator rope arranged to travel between the at least one source of electromagnetic radiation and the at least one sensor by analyzing data received from the at least one sensor.

Moreover, the analysis comprises: generating a representation of the elevator rope as a function of a lengthwise position of the elevator rope.

The control unit may be arranged to detect deviation between the representation of the elevator rope generated from the measurement data received from the at least one sensor and a comparison data. The comparison data may comprise at least one of the following: a comparison value for a width of the elevator rope; a comparison value for a data representing an edge of the elevator rope; a comparison value for a data representing a loose strand of the elevator rope; a comparison value for a data representing a wire-cut of the elevator rope (150).

According to a third aspect, a computer program product for monitoring an elevator rope is provided which computer program product, when executed by at least one processor, cause a control unit of the elevator rope monitoring device to perform the method as described above.

- 5 According to a fourth aspect, an elevator system is provided, the elevator system comprising: an elevator rope monitoring device as defined above, and at least one elevator rope arranged to travel between at least one source of electromagnetic radiation of the elevator rope monitoring device and at least one sensor of the elevator rope monitoring device.

- 10 The expression "a number of" refers herein to any positive integer starting from one, e.g. to one, two, or three.

The expression "a plurality of" refers herein to any positive integer starting from two, e.g. to two, three, or four.

- 15 Various exemplifying and non-limiting embodiments of the invention both as to constructions and to methods of operation, together with additional objects and advantages thereof, will be best understood from the following description of specific exemplifying and non-limiting embodiments when read in connection with the accompanying drawings.

- 20 The verbs "to comprise" and "to include" are used in this document as open limitations that neither exclude nor require the existence of unrecited features. The features recited in dependent claims are mutually freely combinable unless otherwise explicitly stated. Furthermore, it is to be understood that the use of "a" or "an", i.e. a singular form, throughout this document does not exclude a plurality.

25 BRIEF DESCRIPTION OF FIGURES

The embodiments of the invention are illustrated by way of example, and not by way of limitation, in the figures of the accompanying drawings.

Figure 1 illustrates schematically an elevator rope monitoring device as a block diagram according to an embodiment of the invention.

Figure 2 illustrates schematically an elevator system according to an embodiment of the invention.

- 5 Figure 3 illustrates schematically a source of electromagnetic radiation as a block diagram according to an embodiment of the invention.

Figures 4A and 4B illustrate schematically some non-limiting examples of radiation apertures applicable in a context of the present invention according to an embodiment of the invention.

- 10 Figure 5 illustrates schematically an example of a sensor side of the elevator rope monitoring device according to an embodiment of the invention.

Figure 6 illustrates schematically a representation of an elevator rope according to an embodiment of the invention.

- 15 Figure 7 illustrates schematically an example of a control unit of an elevator rope monitoring device according to an embodiment of the invention.

Figure 8 illustrates schematically an example of a method according to an embodiment of the invention.

DESCRIPTION OF THE EXEMPLIFYING EMBODIMENTS

- 20 The specific examples provided in the description given below should not be construed as limiting the scope and/or the applicability of the appended claims. Lists and groups of examples provided in the description given below are not exhaustive unless otherwise explicitly stated.

- 25 Figure 1 schematically illustrates a block diagram of some components and/or entities of an arrangement forming an elevator rope monitoring device to depict an exemplifying framework for one or more embodiments of the present invention. The arrangement may comprise a source of electromagnetic radiation 110 and at least one sensor 130 for receiving the electromagnetic radiation from

the source of the electromagnetic radiation 110. In other words, the source of the electromagnetic radiation 110 may be arranged to emit a radiation beam 120. The elevator rope monitoring device is arranged so that at least one elevator rope 150 travels through the radiation beam 120 so that a projected image of at least a portion of the at least one rope 150 may be generated on the sensor 130. In the non-limiting example of Figure 1 the elevator rope monitoring device is arranged to monitor two ropes for each of which a dedicated sensor 130 is arranged. The sensor 130 type is selected in accordance with the electromagnetic radiation generated by the source 110. Moreover, the arrangement may comprise a processing unit 140 which may be arranged to control of one or more entities of the elevator rope monitoring device. For example, the control unit 140 may be arranged to control of a generation of the radiation beam, e.g. by generating a control signal to the source of electromagnetic radiation 110, as well as reading of a measurement data from the at least one sensor 130 as well as analyzing the measurement data. The control unit 140 may be arranged to generate a representation of the elevator rope 150 from the measurement data received from the at least one sensor 130. For example, the representation of the elevator rope 150 may correspond to a data representing a portion of the elevator rope 150 or a representation of the elevator rope 150 as a function of the elevator rope 150 length along which the measurement data is generated. The mentioned entities, and other possible entities, may be communicatively coupled to each other with an applicable data bus. The data bus is preferably suitable for transferring data fast enough to monitor the condition of the elevator e.g. in a normal use speed of the elevator.

Figure 2 schematically illustrates an elevator system into which an elevator rope monitoring device is installed to. The simplified elevator system comprises a traction sheave 210 over which a number of elevator ropes 150 may travel. The number of elevator ropes 150 connects an elevator car 220 and a counterweight 230. Hence, by providing power to the traction sheave with a hoisting machine (not shown in Figure 2) it is possible to move the elevator car 220 in an elevator shaft between start and destination floors. As may be seen from Figure 2 an advantageous location for mounting the elevator rope monitoring device, i.e. at

least the source of electromagnetic radiation 110 and the at least one sensor 130, may be close to a traction sheave 210 or a deflecting pulley or in case of overspeed governor use, close to pulley. This is because there a deviation of the at least one elevator rope 150 from its track is at minimum which improves, at least in part, the operation of the elevator rope monitoring device. Additionally, by mounting the elevator rope monitoring device, or at least the mentioned portions of it, as mentioned allows the monitoring of the elevator rope 150 in an efficient manner since most of the elevator rope then passes the monitoring device during an operation of the elevator. In other words, the implementation as schematically illustrated in Figure 2 allows an online condition monitoring of the at least one elevator rope 150 during an operation of the elevator. The normal operation may comprise, but is not limited to, a normal elevator operation and a maintenance drive of the elevator.

Figure 3 schematically illustrates a block diagram of a source of electromagnetic radiation 110 according to an example embodiment. The source of electromagnetic radiation 110 of Figure 3 illustrates some components and entities according to the example embodiment. According to the embodiment of the invention as schematically depicted in Figure 3 the source of electromagnetic radiation 110 may comprise a casing 300 into which a radiator element 310 configured to emit radiation applied in the elevator rope monitoring device is arranged to. For example, the radiator element 310 may be a diode emitting electromagnetic radiation having a predetermined wavelength band. The emitted electromagnetic radiation may be taken in a beam form to a lens 320 comprising a number of lenses. The type of lens 320 may e.g. be selected so that it may collimate rays of the radiation originating from the radiation element 310 to substantially parallel rays directed e.g. to infinity (i.e. the source of electromagnetic radiation, such as the laser diode, is positioned into a focal point of the one or more lenses). A non-limiting example of the lens 320 may be a convex collimation lens made of silicate, plastic or glass, for example. The collimated radiation may be directed, by means of the lens 320 to a radiation aperture 330, also called as illumination aperture. The radiation aperture 330 is arranged to block at least a portion of the collimated radiation for generating a

radiation beam of a desired format. According to an example embodiment such a radiation aperture 330 is applied in the source of electromagnetic radiation 110, which may generate at least one radiation beam having a linear form, i.e. a linear radiation beam is generated. For sake of clarity the linear radiation beam shall be understood as a planar beam. Moreover, in some example embodiments the source of electromagnetic radiation 110 may comprise a radiation window 340. The radiation window 340 is arranged to close the closing 300 and in that manner to protect the source of electromagnetic radiation from dirt. The radiation window may e.g. be made of glass through which the applied electromagnetic radiation, and, thus, the generated linear radiation beam may be output from the source 110 towards the at least one sensor 120.

Especially in example embodiments in which the electromagnetic radiation is in a range of wavelengths being so-called visible light it may be necessary to protect the radiation window 340 from dirt. In some embodiment a controllable protection cover for protecting the radiation window may be arranged on a surface of the radiation window 340 facing the at least one sensor 120. For example, the protection cover may be equipped with a transport device i.e. an actuator, such as with a solenoid, an electric motor or a servomotor, which may generate power for displacing the protection cover from the radiation window 340 at least in part e.g. in accordance with a control signal generated by the control unit 140. Alternatively or in addition, the protection of the radiation window 340 may be arranged so that there is arranged a number of detachable plastics protecting films stacked on top of each other on the radiation window 340. Hence, the detachable plastic protecting films may be removed, e.g. one at a time, so that dirty outmost layer may be removed by detaching the topmost film, and in that manner the elevator rope monitoring device may be maintained operative. Usually applicable plastic protecting films are transparent especially when the electromagnetic radiation is visible light, but it may be dependent on the applied electromagnetic radiation.

Figures 4A and 4B schematically illustrate some non-limiting examples of radiation apertures 330 which may be applied in the source of electromagnetic

radiation 110 of the elevator rope monitoring device especially when the aim is to generate at least one linear radiation beam towards the at least one sensor 130. The radiation aperture 330 of Figure 4A comprises one aperture, i.e. hole, whereas the radiation aperture 330 comprises two apertures for generating two linear radiation beams. Advantageously, the radiation aperture is mounted in the source 110 so that the generated linear radiation beam extends over a rope under monitoring so that the sensor 130 receives radiation passing the rope on the both sides. The radiation aperture is advantageously made of material being suitable to block at least part of the radiation received from the radiator element 310 through the collimation lens 320. For example, the radiation aperture may be made of steel.

An advantage of using the radiation aperture 330 is that especially in various embodiments in which the electromagnetic radiation is visible light it is preferred to block at least part of the light to end up to the sensor side, because the light falling outside a detection area of the sensor causes degradation in a contrast of an image generated from the data obtainable from the sensor 130. Hence, the radiation aperture 330 as such is not an essential element but may be used in various embodiments for improving a monitoring result of the device.

The source of electromagnetic radiation 110 may be arranged to generate any suitable electromagnetic radiation and the sensor 130 is selected accordingly i.e. the source and the sensor are matched to operate together. According to an example embodiment the electromagnetic radiation may be visible light, such as having a wavelength of about 380 to 740 nanometers. According to an advantageous embodiment the elevator rope monitoring device may be implemented so that the electromagnetic radiation is laser light. The laser light has known advantages, such as coherence, directionality, monochromatic, and high intensity, e.g. with respect to ordinary light, and for this reason it is suitable for measurement applications. Hence, the radiator element 310 may be selected accordingly. For example, the radiator element 310 may be an applicable laser diode, such a single mode laser having an output power of 5 mW. In case of the radiation is laser light the source of electromagnetic radiation 110 may, hence,

generate a line laser pattern towards the sensor 130, and any object, such as a rope 150, therebetween.

The elevator rope monitoring device also comprises at least one sensor 130 suitable for detecting the electromagnetic radiation used in the elevator rope monitoring device. Advantageously, the at least one sensor 130 is selected so that a shadow cast by a rope 150 under monitoring fits entirely in a detection area of the sensor 130 in response to a radiation. However, in some embodiments it may be arranged that only one edge of the rope 150 is monitored, or it may be arranged that a shadow of one edge of the rope 150 is detected by one sensor 130 and the shadow of the other edge of the rope 150 is detected by another sensor 130. According to still further example embodiment the sensor 130 may be selected, by size, so that shadows of a plurality of monitored ropes 150 fit in the detection area of the sensor 130 and the analysis of the conditions of the sensors 130 may be arranged separately through signal processing.

Figure 5 schematically illustrates an example of a sensor side of the elevator rope monitoring device. The sensor side may be implemented so that at least one sensor 130 may be mounted on a circuit board 510 comprising necessary hardware and software components for controlling an operation of the at least one sensor 130 in such a way that the sensor 130 may detect radiation and data generated at least in accordance with the received radiation may be read from the sensor 130. According to some example embodiments the at least one sensor 130 may be protected with a window 520 e.g. made of glass. In addition, in some embodiments the window 520 may be protected with a protection cover or with a number of detachable plastic protecting films in order to prevent dirt to end up on the window 520, or on the sensor 130, and/or to allow a removal of the dirt from the window 520, or the sensor 130, e.g. by detaching a plastic protecting film from the window 520. Hence, the implementation of the protection cover and/or the detachable plastic protecting films may correspond to ones discussed in the context of the source of electromagnetic radiation 110.

An applicable sensor 130 may be a so-called linear photosensitive array which may refer to a sensor comprising photo sensing elements in one row forming, hence, a pixel row. Such a sensor 130 has an advantage that it may be read in a fast way. However, other sensor implementations may also be applied to, such as sensors comprising sensing elements in a wider area than just in one row, such as a matrix sensor. In some implementations, the matrix sensor may be applied in such a way where one line of the matrix of sensor elements is dedicated for laser and a rest of the sensor elements in the matrix are used for capturing a normal photo image on the rope(s).

As discussed, the source of electromagnetic radiation 110 of the elevator rope monitoring device and the sensor 130 of the elevator rope monitoring device are mutually positioned, with respect to each other, so that the at least one elevator rope 150 under monitoring may be arranged to travel between the source 110 and the sensor 130 and the orientation of the rope 150 in the elevator rope monitoring device is such that at least portion of a shadow of the rope 150 projects on the sensor 130, and, hence, a portion of the radiation passes the rope 150 and reaches the sensor 130 directly.

Regarding the reading of data from the sensor it is advantageous to read the pixels simultaneously. The simultaneous reading of the pixels mitigates any impact of a vibration of the rope to the result of the monitored parameter, such as to the rope width, such as a diameter in a context of ropes having circular cross section. This may be important at least in some embodiments, since the ropes are always vibrating in a plane perpendicular to rope longitude axis, which otherwise could destroy an accuracy of the monitoring.

Next, at least some aspects of the present invention are now described by introducing aspects relating to an analysis of data obtained from at least one sensor 130. First, data generated in response to a provision of electromagnetic radiation by a source of electromagnetic radiation 110 may be read out from the sensor 130 i.e. from data storing entities, such as pixels of the sensor. Depending on the implementation the reading of the data from the sensor 130 may be arranged so that the reading of data is performed simultaneously from

the sensor 130 and post-processing of the data may e.g. be initiated by analyzing the measurement data so that the analysis is started from the measurement data obtained, i.e. read, from at least one outmost pixel, preferably from both outmost pixels, residing at both ends of the sensor 130 and continuing the analysis e.g. pixel-by-pixel to an inward direction towards a center pixel(s) of the sensor 130. This kind of reading technique may be called as an outside-inside reading. A more preferred implementation in the context of the present invention, however, may be that the processing, or analyzing, of the measurement data obtained from the pixels simultaneously, i.e. at the same instant of time, may be arranged so that the measurement data obtained from center pixel(s) is processed, i.e. analyzed, first and the processing direction is outwards from the center i.e. towards the outmost pixels i.e. outward direction. This corresponds to a phenomenon that a shadow of the elevator rope generates data in the pixels residing in the center of the sensor and by reading outwards one or more edges may be detected. This kind of reading technique may be called as an inside-outside reading. Moreover, it may be arranged that at least some of the pixels are not read at all. For example, since at least one aim of the present invention may be to detect abnormalities in an elevator rope 150 through an establishment of a representation of the elevator rope 150 i.e. from an image representing a shadow of the rope 150 it may not be necessary to read pixels representing a center of the rope 150 because detections with respect to the abnormalities are challenging to make from that data, and an edge area of the rope is more interesting. In this manner, i.e. by selecting a detection area from the sensor 130, it is possible to optimize the data to be read from the sensor 130 and to be analyzed by the control unit 140.

As described, by reading the sensor data, in a row-by-row, and preferably all pixels simultaneously in order to maintain an accuracy, in response to moving of the rope 150 along its travel path, it is possible to generate a representation e.g. as an image representing the elevator rope 150 within an inspected length of the rope 150. Figure 6 schematically illustrates an example of the generated representation from measurement data read from the sensor in consecutive reading phases which data is combined to generate the image.

Further data analysis may be selected in accordance with a characteristic under monitoring. At least the following characteristics may be derived from the representation generated from data received from the at least one sensor 130: rope width, rope defect, loose strand of the rope, which either alone or in any combination may provide information for performing a detection of abnormality of the rope 150 under monitoring.

According to an embodiment of the invention the rope width may be determined by detecting a first edge of the rope 150 and a second edge of the rope from the sensor data as described above, and by determining of the width of the rope on the basis of pixels between the two edges, such as based on a number of pixels between the two edges storing data representing a certain color, such as black. For example, a pixel size may be known and based on that information the width may be determined. For the detection of the first and the second edge of the rope 150 rules may be determined and by applying them to the measurement data obtained from the sensor 130 the edges may be found. In response to the determination of the width of the rope, it may be compared to a comparison value defining a preferred width of the elevator rope 130, and a detection of abnormality may be performed if the values deviate from each other more than a comparison value possibly with some tolerance limit.

According to another embodiment of the invention an analysis for detecting an abnormality of the rope may comprise, e.g. in addition to the rope width analysis, may comprise a rope defect analysis. The rope defect analysis may e.g. be arranged to generate a detection if a strand of the rope 150 is extruded among other strand spirals or single wire-cuts are extruded out of strand. An example of such a situation is schematically disclosed in Figure 6 wherein a wire in one strand 610 is extruded from rope 150. The detection of this type may be performed because the extruded strand 610 generates a detection i.e. additional black pixels forming a narrow peak in the data obtained from the sensor 130 which is detectable from the data representing the rope 130. Similar detections of the rope defect may be implemented with pattern recognition analysis of the

image data e.g. based on pixels storing data representing black pixels originating from the defect in the rope 150.

According to a still further embodiment of the invention an analysis for detecting an abnormality of the rope 150 may comprise, e.g. in addition to the above
5 described analysis, a loose strand and/or wire-cut analysis. The loose strand analysis, i.e. a detection of the loose strand, may comprise a detection of a number of loose strands by performing a Fast Fourier Transform (FFT), such as a short-time Fourier transform, of a measurement time with respect to a rope
10 150 width data. As the measurement data is represented in a frequency domain through the Fourier transform it is possible to detect frequency components, such as rising lower frequency components, in the frequency spectrogram, which may represent one or more loose strands of the rope 150. For example, the control unit 140 may have access to a comparison value of a loose strand which is compared with value obtainable from the measurement data
15 represented in the frequency domain. In response to a detection of a number of loose strands it may be decided, by applying predetermined rules, if the rope 150 is abnormal or not. For example, the comparison value, i.e. the rule, may define a gradient of the rising lower frequency component and/or an amplitude of it in order to determine if the frequency component in question represents the
20 loose strand in the elevator rope 150 or not. In case one or more rising lower frequency components are identified, the control unit 150 may be arranged to generate an indication on a loose strand in the elevator rope 150, which may be judged to be a defect of the rope 150.

As is derivable from the description herein various embodiments of the invention
25 allow detecting an abnormality of the elevator rope 150. With the present invention it is possible to establish sophisticated solution e.g. by illustrating the elevator rope 150 under monitoring as a function of a position in its length, i.e. lengthwise position of the elevator rope 150. More specifically, outer dimensions of the elevator rope 150, i.e. the edge of the elevator rope 150, may be under
30 interest. This kind of illustration may require that a speed of the elevator rope 150 is known. The speed information may e.g. be derived with motor encoder

measurement. On the other hand, if exact measurement position of the elevator rope 150 is not known e.g. from any external reference, also the strand peak/valley variation, as may e.g. be seen from Figure 6 (the edge area of the rope 150), may be used as means for estimating measurement position as a function of rope run length. By means of this it is possible to establish the illustration of the elevator rope 150, and, hence, to determine the measurement position under interest, such as a position having abnormality, from the elevator rope 150.

By applying the above described non-limiting examples of an analysis of the rope 150 it is possible to detect abnormalities in the rope 150. Prior to performing the analysis itself the data obtained from the sensor 130 may be processed so that any interference e.g. originating from background light may be deducted from the data obtained from the sensor during the measurement. The amount of background light may e.g. be determined through a test measurement without performing a radiation with the source of electromagnetic radiation 110. For example, each pixel may detect black to white color between a pixel value 0 – 255. Hence, such a setup may be arranged that a detection of black pixel is set with pixel values 0-126 and a detection of white pixels is set with pixel values 127-255.

Figure 7 schematically illustrates a control unit 140 according to an embodiment of the invention. The control unit 140 may comprise a processing unit 710, a memory 720 and a communication interface 730 among other entities. The processing unit 710, in turn, may comprise one or more processors arranged to implement one or more tasks for implementing at least part of the method steps as described. For example, the processing unit 710 may be arranged to control an operation of a source of electromagnetic radiation 110 and/or at least one sensor 130, and even an operation of the elevator, as well as any other entities of the present invention in the manner as described. The memory 720 may be arranged to store computer program code which, when executed by the processing unit 710, cause the control unit 140 to operate as described. Moreover, the memory 720 may be arranged to store, as described, the

reference value, and any other data. The communication interface 730 may be arranged to implement, e.g. under control of the processing unit 710, one or more communication protocols enabling the communication with the entities as described. The communication interface may comprise necessary hardware and software components for enabling e.g. wireless communication and/or communication in a wired manner.

Some aspects of the present invention relate to a method for monitoring an elevator rope 150. A non-limiting example of the method according to an embodiment of the invention is schematically illustrated in Figure 8. The elevator rope monitoring device may be set to an operational state for initiating the method by generating 810, by a control unit 140 of an elevator rope monitoring device, a control signal to at least one source of electromagnetic radiation 110 for emitting a radiation beam. In response to an emit of the radiation beam the control unit 140 may receive 820 a measurement data from at least one sensor 120 receiving at least part of an emitted radiation beam. Further, in response to the receipt of the measurement data the control unit 140 may be arranged to detect 830 an abnormality of an elevator rope 150 arranged to travel between the at least one source of electromagnetic radiation 110 and the at least one sensor 120 by analyzing data received from the at least one sensor 120. According to various embodiments of the invention the analysis may comprise an operation in which it is generated a representation of the elevator rope 150 as a function of an elevator rope 150 length. In other words, a representation of the elevator rope 150 may be generated along the length of the elevator rope 150 which is moved through the at least one source of electromagnetic radiation 110 and the at least one sensor 120. The analysis, performed by the control unit 140, may be arranged to detect one or more deviations between the representation of the elevator rope 150 generated from the measurement data received from the at least one sensor 120 and a comparison data. The comparison data may comprise at least one of the following: a comparison value for a width of the elevator rope 150; a comparison value for a data representing an edge of the elevator rope 150; a comparison value for a data representing a loose strand of the elevator rope 150; a comparison value for a data representing

a wire-cut of the elevator rope 150. The method according to various embodiments of the present invention may comprise further operation as described in the context of the description of the elevator rope monitoring device.

Moreover, some aspects of the present invention may relate to a computer program product for monitoring an elevator rope 150 which, when executed by at least one processor, cause a control unit of the elevator rope monitoring device to perform the method as described. The computer program product may be stored in a non-transitory computer-readable medium, such as an applicable memory unit, accessible to the processor configured to execute the computer program product.

Some further aspects of the invention may relate to an elevator system comprising: an elevator rope monitoring device as described and at least one elevator rope 150 arranged to travel between at least one source of electromagnetic radiation 110 of the elevator rope monitoring device and at least one sensor 120 of the elevator rope monitoring device. Naturally, the elevator system may comprise further elements and entities as e.g. discussed in the description of Figure 2.

The solution according to the present invention enable a condition monitoring of elevator ropes with respect to at least some of the following aspects: a change in width of the rope e.g. caused by non-lubricated rope, a detection of cut wires within the rope, a detection of loose strand, a detection of a strained rope, a detection of slipping rope. The described solution is fast enough to be capable of inspecting the rope during normal usage speed or maintenance drive speed in high enough resolution.

The specific examples provided in the description given above should not be construed as limiting the applicability and/or the interpretation of the appended claims. Lists and groups of examples provided in the description given above are not exhaustive unless otherwise explicitly stated.

WHAT IS CLAIMED IS:

1. An elevator rope monitoring device comprising:
at least one source of electromagnetic radiation (110) for emitting a radiation
5 beam,
at least one sensor (120) for receiving at least part of an emitted radiation beam,
a control unit for detecting an abnormality of an elevator rope (150) arranged to
travel between the at least one source of electromagnetic radiation (110) and
the at least one sensor (120) by analyzing measurement data received from the
10 at least one sensor (120).
2. The elevator rope monitoring device of the claim 1, wherein the at least
one source of electromagnetic radiation (110) comprises at least one lens (320)
for collimating the radiation.
3. The elevator rope monitoring device of the claim 2, wherein the at least
15 one source of electromagnetic radiation (110) and the at least one lens (320)
are mutually positioned so that the at least one source of electromagnetic
radiation (110) is positioned into a focal point of the at least one lens (320).
4. The elevator rope monitoring device of any of the preceding claims,
wherein the at least one source (110) of electromagnetic radiation further
20 comprises at least one radiation aperture for blocking at least a portion of the
radiation for generating a linear radiation beam.
5. The elevator rope monitoring device of any of the preceding claims,
wherein the at least one source of electromagnetic radiation (110) further
comprises a radiation window for emitting the radiation beam towards the at
25 least one sensor (120) from the at least one source (110) of electromagnetic
radiation.

6. The elevator rope monitoring device of any of the preceding claims, wherein the at least one source (110) of electromagnetic radiation comprises a controllable protection cover for protecting the radiation window from dirt, the controllable protection cover is arranged on a surface of the radiation window facing the at least one sensor (120).

7. The elevator rope monitoring device of any of the preceding claims 1-5, wherein the at least one source of electromagnetic radiation (110) comprises a protection cover arranged on a surface of the radiation window facing the at least one sensor (120), the protection cover is implemented with a number of detachable plastic protecting films stacked on top of each other on the radiation window.

8. The elevator rope monitoring device of any of the preceding claims, wherein the at least one sensor (120) is a linear photosensitive array detector.

9. The elevator rope monitoring device of any of the preceding claims, wherein control unit (140) is arranged to perform an analysis by:

generating a representation of the elevator rope (150) as a function of a lengthwise position of the elevator rope (150).

10. The elevator rope monitoring device of any of the preceding claims, wherein the control unit (140) is arranged to detect deviation between the data received from the at least one sensor (120) and a comparison data in the analysis.

11. The elevator rope monitoring device of the claim 10, wherein the comparison data comprises at least one of the following: a comparison value for a width of the elevator rope (150); a comparison value for a data representing an edge of the elevator rope (150); a comparison value for a data representing a loose strand of the elevator rope (150); a comparison value for a data representing a wire-cut of the elevator rope (150).

12. The elevator rope monitoring device of any of the preceding claims, wherein the at least one source of electromagnetic radiation (110) is arranged to generate a laser light.

13. The elevator rope monitoring device of the claim 12, wherein the at least
5 one source of electromagnetic radiation (110) comprises at least one laser diode for generating the laser light.

14. A method for monitoring an elevator rope (150), the method comprising:

generating (810), by a control unit (140) of an elevator rope monitoring device, a control signal to at least one source of electromagnetic radiation (110) for
10 emitting a radiation beam,

receiving (820), by the control unit (140) of the elevator rope monitoring device, a measurement data from at least one sensor (120) receiving at least part of an emitted radiation beam,

detecting (830), by the control unit (140) of the elevator rope monitoring device,
15 an abnormality of an elevator rope (150) arranged to travel between the at least one source of electromagnetic radiation (110) and the at least one sensor (120) by analyzing data received from the at least one sensor (120).

15. The method of the claim 14, wherein, wherein the analysis comprises:

generating a representation of the elevator rope (150) as a function of a
20 lengthwise position of the elevator rope (150).

16. The method of any of the preceding claims 14 or 15, wherein the control unit (140) is arranged to detect deviation between the representation of the elevator rope (150) generated from the measurement data received from the at least one sensor (120) and a comparison data.

25 17. The method of the preceding claim 16, wherein the comparison data comprises at least one of the following: a comparison value for a width of the elevator rope (150); a comparison value for a data representing an edge of the

elevator rope (150); a comparison value for a data representing a loose strand of the elevator rope (150); a comparison value for a data representing a wire-cut of the elevator rope (150).

18. A computer program product for monitoring an elevator rope (150) which,
5 when executed by at least one processor, cause a control unit of the elevator rope monitoring device to perform the method according to any of claims 14-17.

19. An elevator system comprising:

an elevator rope monitoring device of claim 1, and

10 at least one elevator rope (150) arranged to travel between at least one source of electromagnetic radiation (110) of the elevator rope monitoring device and at least one sensor (120) of the elevator rope monitoring device.

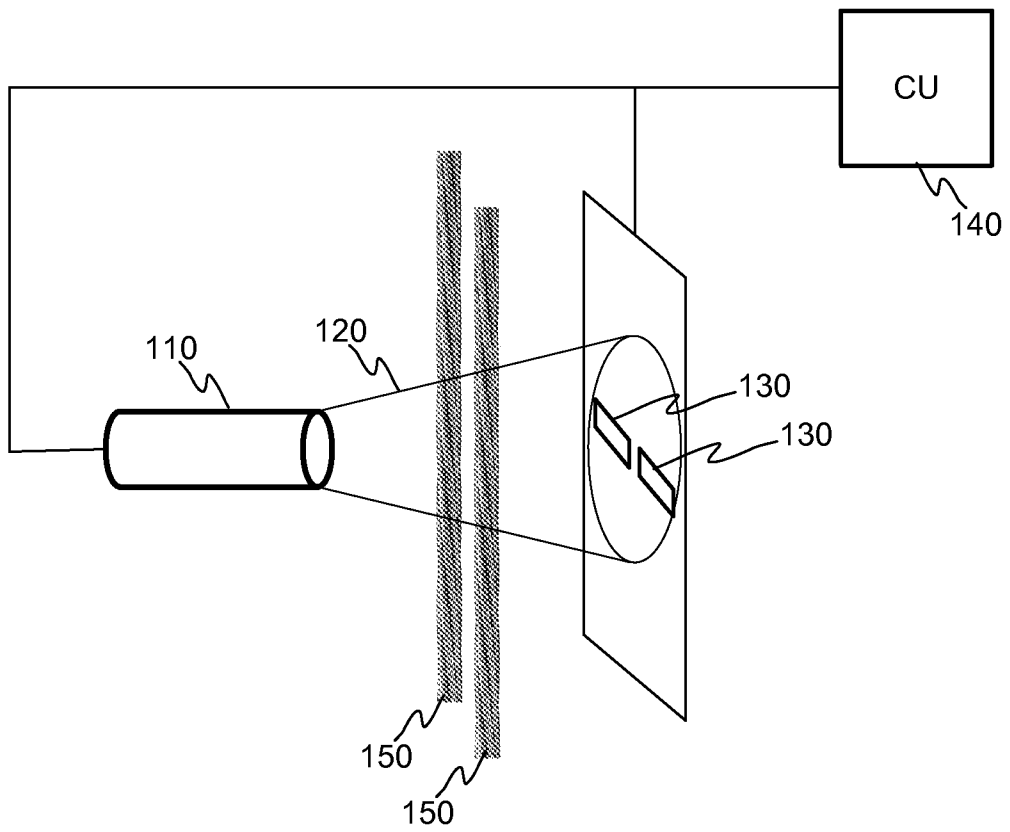

FIGURE 1

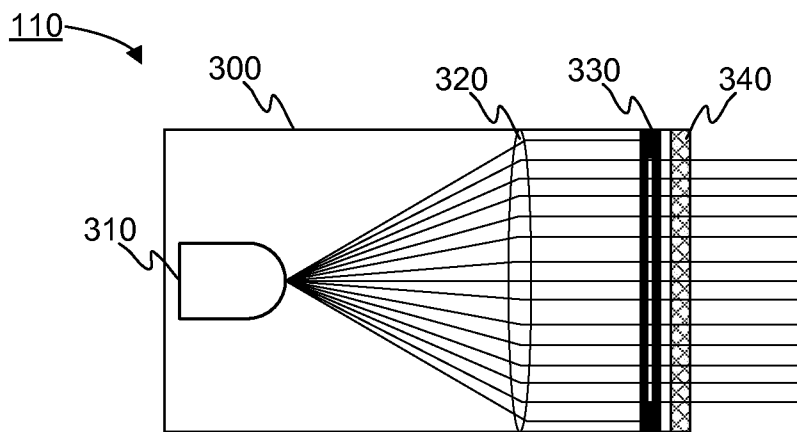

FIGURE 3

2/5

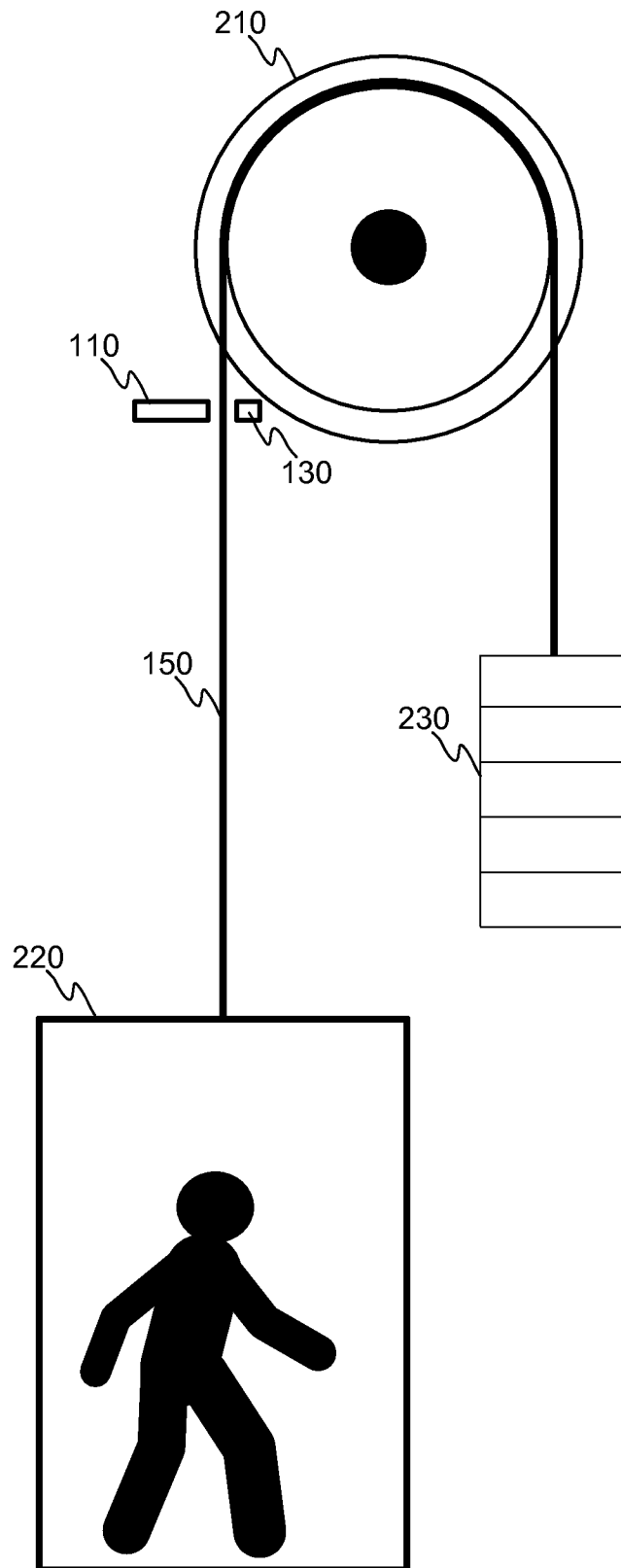

FIGURE 2

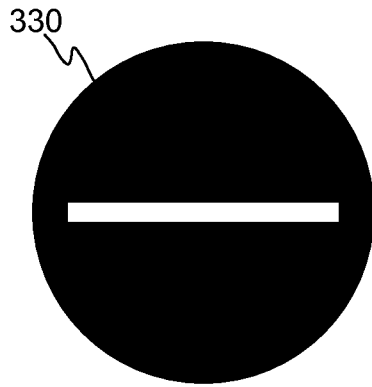

FIGURE 4A

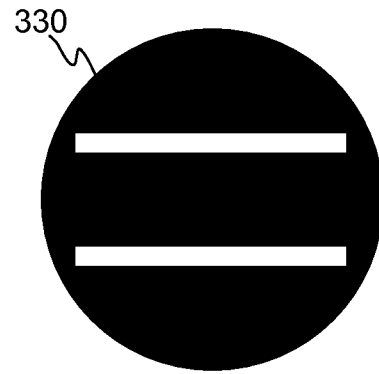

FIGURE 4B

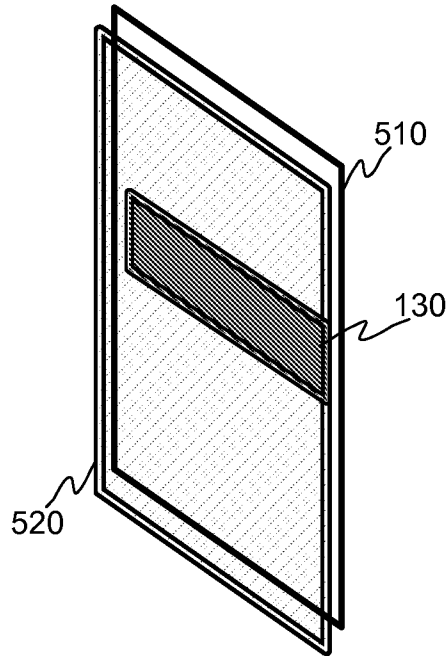

FIGURE 5

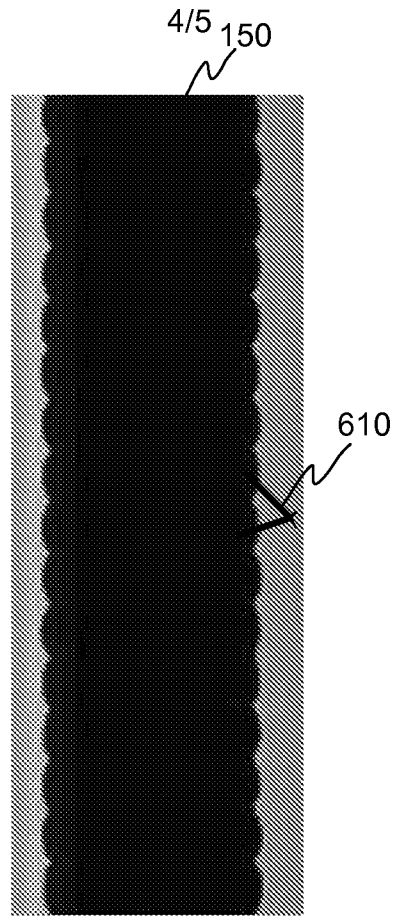

FIGURE 6

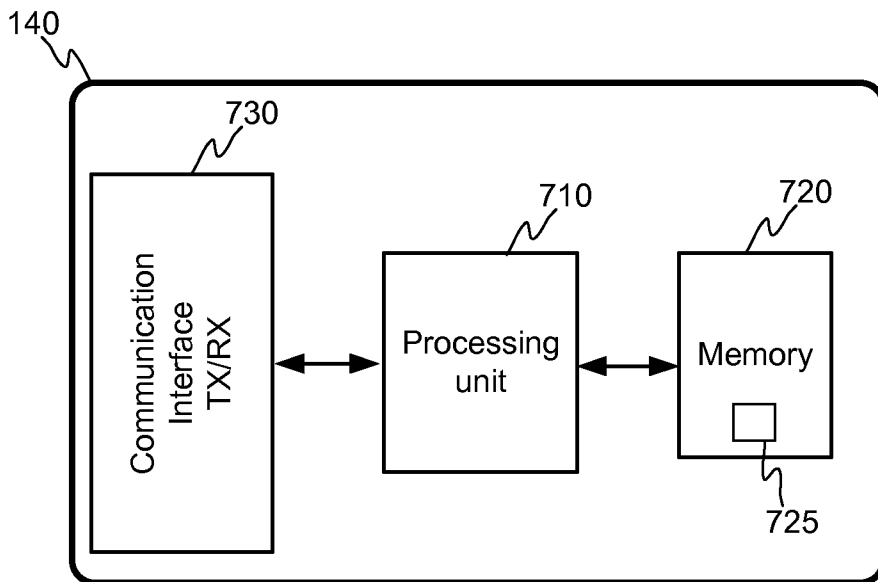

FIGURE 7

5/5

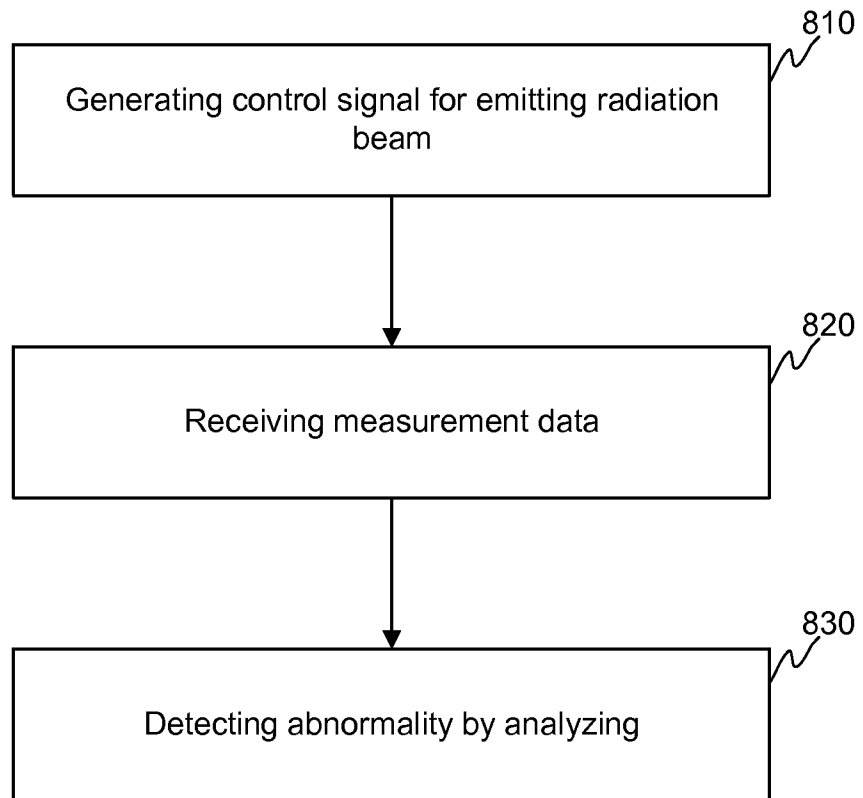

FIGURE 8

INTERNATIONAL SEARCH REPORT

International application No.

PCT/FI2019/050587

A. CLASSIFICATION OF SUBJECT MATTER

See extra sheet

According to International Patent Classification (IPC) or to both national classification and IPC

B. FIELDS SEARCHED

Minimum documentation searched (classification system followed by classification symbols)

IPC: B66B, G12B, G01D

Documentation searched other than minimum documentation to the extent that such documents are included in the fields searched

FI, SE, NO, DK

Electronic data base consulted during the international search (name of data base, and, where practicable, search terms used)

EPODOC, EPO-Internal full-text databases, Full-text translation databases from Asian languages, WPIAP

C. DOCUMENTS CONSIDERED TO BE RELEVANT

Category*	Citation of document, with indication, where appropriate, of the relevant passages	Relevant to claim No.
X Y	US 2013126737 A1 (HUSMANN JOSEF [CH] et al.) 23 May 2013 (23.05.2013) whole document	1-5, 7-19 6
Y	EP 0942320 A2 (CANON KK [JP]) 15 September 1999 (15.09.1999) whole document	6
A	WO 2017219727 A1 (DOU BOLIN [CN]) 28 December 2017 (28.12.2017) whole document & machine translation into English by EPO [online] EPOQUENET TXPTEA/EPO	1-19

 Further documents are listed in the continuation of Box C.
 See patent family annex.

* Special categories of cited documents:	"T" later document published after the international filing date or priority date and not in conflict with the application but cited to understand the principle or theory underlying the invention
"A" document defining the general state of the art which is not considered to be of particular relevance	"X" document of particular relevance; the claimed invention cannot be considered novel or cannot be considered to involve an inventive step when the document is taken alone
"D" document cited by the applicant in the international application	"Y" document of particular relevance; the claimed invention cannot be considered to involve an inventive step when the document is combined with one or more other such documents, such combination being obvious to a person skilled in the art
"E" earlier application or patent but published on or after the international filing date	"&" document member of the same patent family
"L" document which may throw doubts on priority claim(s) or which is cited to establish the publication date of another citation or other special reason (as specified)	
"O" document referring to an oral disclosure, use, exhibition or other means	
"P" document published prior to the international filing date but later than the priority date claimed	

 Date of the actual completion of the international search
 08 November 2019 (08.11.2019)

 Date of mailing of the international search report
 12 November 2019 (12.11.2019)

 Name and mailing address of the ISA/FI
 Finnish Patent and Registration Office
 FI-00091 PRH, FINLAND
 Facsimile No. +358 29 509 5328

 Authorized officer
 Annele Siltanen
 Telephone No. +358 29 509 5000

INTERNATIONAL SEARCH REPORT

International application No.

PCT/FI2019/050587

C (Continuation). DOCUMENTS CONSIDERED TO BE RELEVANT

Category*	Citation of document, with indication, where appropriate, of the relevant passages	Relevant to claim No.
A	CN 102602759 B (RHINE LIFT CHINA CO LTD) 10 December 2014 (10.12.2014) whole document & machine translation into English by EPO [online] EPOQUENET TXPCNEB/EPO	1-19

INTERNATIONAL SEARCH REPORT
Information on Patent Family Members

International application No.
PCT/FI2019/050587

US 2013126737 A1	23/05/2013	US 9063008 B2	23/06/2015
		CN 103003184 A	27/03/2013
		CN 103003184 B	20/01/2016
		CN 103025639 A	03/04/2013
		CN 103025639 B	29/06/2016
		EP 2595910 A1	29/05/2013
		EP 2595911 A1	29/05/2013
		EP 2595911 B1	21/10/2015
		US 2013119256 A1	16/05/2013
		US 9063009 B2	23/06/2015
		WO 2012010431 A1	26/01/2012
		WO 2012010433 A1	26/01/2012

EP 0942320 A2	15/09/1999	EP 0942320 B1	14/03/2007
		CN 1240274 A	05/01/2000
		CN 1196023 C	06/04/2005
		DE 69935467 D1	26/04/2007
		DE 69935467 T2	13/12/2007
		JP H11331660 A	30/11/1999
		JP 3809291 B2	16/08/2006
		KR 19990077719 A	25/10/1999
		TW 448687 B	01/08/2001
		US 6457881 B1	01/10/2002
		US 2002181957 A1	05/12/2002
		US 6835008 B2	28/12/2004

WO 2017219727 A1	28/12/2017	CN 106018544 A	12/10/2016
		CN 106018544 B	20/03/2018
		EP 3477295 A1	01/05/2019
		JP 2019518976 A	04/07/2019
		US 2019063903 A1	28/02/2019

CN 102602759 B	10/12/2014	CN 102602759 B	10/12/2014
----------------	------------	----------------	------------

CLASSIFICATION OF SUBJECT MATTER

IPC
B66B 7/12 (2006.01)
G01J 5/10 (2006.01)
G01N 27/82 (2006.01)