

(19) World Intellectual Property Organization
International Bureau



(43) International Publication Date
13 March 2008 (13.03.2008)

PCT

(10) International Publication Number
WO 2008/029381 A2

- (51) **International Patent Classification:**
A61M 15/06 (2006.01) A61M 11/04 (2006.01)
- (21) **International Application Number:**
PCT/IE2007/000081
- (22) **International Filing Date:**
5 September 2007 (05.09.2007)
- (25) **Filing Language:** English
- (26) **Publication Language:** English
- (30) **Priority Data:**
S2006/0658 5 September 2006 (05.09.2006) IE
- (71) **Applicant (for all designated States except US):**
OGLESBY & BUTLER RESEARCH & DEVELOPMENT LIMITED [IE/IE]; Industrial Estate, Dublin Road, Carlow (IE).
- (72) **Inventors; and**
- (75) **Inventors/Applicants (for US only):** **OGLESBY, Alfred, Peter** [GB/IE]; Castle Hill, Carlingford, County Louth (IE). **STOREY, John, Joseph** [IE/IE]; Hazelwood Cottage, Eyne, Portlaoise, County Laois (IE).
- (74) **Agent:** **F.F. GORMAN & CO.**; 15 Clanwilliam Square, Dublin 2 (IE).

- (81) **Designated States (unless otherwise indicated, for every kind of national protection available):** AE, AG, AL, AM, AT, AU, AZ, BA, BB, BG, BH, BR, BW, BY, BZ, CA, CH, CN, CO, CR, CU, CZ, DE, DK, DM, DO, DZ, EC, EE, EG, ES, FI, GB, GD, GE, GH, GM, GT, HN, HR, HU, ID, IL, IN, IS, JP, KE, KG, KM, KN, KP, KR, KZ, LA, LC, LK, LR, LS, LT, LU, LY, MA, MD, ME, MG, MK, MN, MW, MX, MY, MZ, NA, NG, NI, NO, NZ, OM, PG, PH, PL, PT, RO, RS, RU, SC, SD, SE, SG, SK, SL, SM, SV, SY, TJ, TM, TN, TR, TT, TZ, UA, UG, US, UZ, VC, VN, ZA, ZM, ZW.
- (84) **Designated States (unless otherwise indicated, for every kind of regional protection available):** ARIPO (BW, GH, GM, KE, LS, MW, MZ, NA, SD, SL, SZ, TZ, UG, ZM, ZW), Eurasian (AM, AZ, BY, KG, KZ, MD, RU, TJ, TM), European (AT, BE, BG, CH, CY, CZ, DE, DK, EE, ES, FI, FR, GB, GR, HU, IE, IS, IT, LT, LU, LV, MC, MT, NL, PL, PT, RO, SE, SI, SK, TR), OAPI (BF, BJ, CF, CG, CI, CM, GA, GN, GQ, GW, ML, MR, NE, SN, TD, TG).

Declaration under Rule 4.17:

— as to applicant's entitlement to apply for and be granted a patent (Rule 4.17(ii))

[Continued on next page]

(54) **Title:** A CONTAINER COMPRISING VAPORISABLE MATTER FOR USE IN A VAPORISING DEVICE FOR VAPORISING A VAPORISABLE CONSTITUENT THEREOF

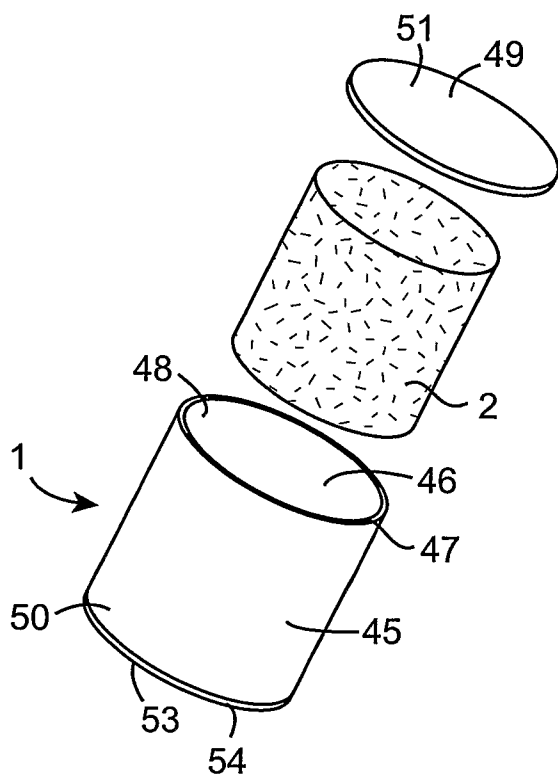

(57) **Abstract:** A disposable sachet (1) of tobacco (2) for use with a gas powered vaporising device (5) for vaporising vaporisable constituents of the tobacco (2) comprises a side wall (45) of an impermeable paper based material and an upstream end cap (49) and a downstream end cap (53) which together define a hollow interior region (46) for the tobacco (2). The sachet (1) is shaped and sized to releasably and snugly engage a vaporising chamber (15) of the vaporising device (5) with a heat transfer member (25) therein extending into the hollow interior region (46) of the sachet (1). The upstream end cap (49) is of a paper based permeable material which is permeable to air and the downstream end cap (53) is of a similar permeable paper based material which is permeable to an aerosol formed by vaporised constituents from the tobacco (2) entrained in air drawn through the hollow interior region (46) of the sachet (1) when the sachet (1) is in the vaporising chamber (15). The vaporising chamber (15) is formed by a socket portion (16) and a releasable plug portion (18), within which a hollow interior region (22) is formed for accommodating the sachet (1).

WO 2008/029381 A2



Published:

- *without international search report and to be republished upon receipt of that report*

“A container comprising vaporisable matter for use in a vaporising device
for vaporising a vaporisable constituent thereof”

The present invention relates to a container comprising vaporisable matter for
5 placing in a vaporising chamber of a vaporising device for producing an aerosol of a
vaporisable constituent of the vaporisable matter, and the invention also relates to a
method for vaporising a vaporisable constituent of vaporisable matter. The invention
also relates to a combination of the container and a vaporising device.

10 Vaporising devices for producing an aerosol of a vaporisable constituent of
vaporisable matter, such as herbs, plant matter and the like from which aerosols of
flavour constituents, medicinal constituents and psychoactive constituents can be
produced are known. For example, heating devices for vaporising vaporisable
constituents from tobacco, mullein, passion flower, cloves, yohimbe, mint, tea,
15 eucalyptus, camomile and other such herbs and plant matter are known. Typically,
such devices comprise a vaporising chamber in which the matter to be vaporised is
placed, and heat from a heat source, for example, a gas powered heat source or an
electrically powered heat source, is transferred to the vaporising chamber for heating
the vaporisable matter contained therein to an appropriate temperature for
20 vaporising the vaporisable constituent or constituents thereof for in turn forming the
aerosol. In general, the vaporising chamber of such devices are suitable for
receiving the matter to be vaporised in loose form, although some heating devices
for heating tobacco for vaporising the vaporisable constituents therein are adapted
for receiving the tobacco in the form of a cigarette. Such heating devices heat the
25 vaporisable matter to a temperature below its combustion temperature in order to
avoid combustion of the vaporisable matter, but to a temperature which is sufficient
to cause desirable constituents in the matter to be vaporised. In devices for
vaporising desirable constituents in tobacco, the tobacco is heated to a temperature
generally in the range of 130°C to 230°C, and while such temperatures are sufficient
30 for vaporising the desirable vaporisable constituents, they are insufficient to raise the
tobacco to its combustion temperature.

One such device for producing an aerosol of a vaporisable constituent of vaporisable matter is disclosed in PCT published Application Specification No.

WO 2006/082571 A1. The device of this PCT Application is gas powered and comprises a vaporising chamber which is formed by a socket portion and a hollow
5 plug portion. Vaporisable matter is placed in the plug portion, which in turn is engaged in the socket portion, and heat is transferred to the vaporising chamber from a gas powered heat source. An aerosol of air entrained with vapour of the vaporised constituent is drawn from the vaporising chamber through an aerosol accommodating tube. In general, in such devices the vaporisable matter, the
10 constituent of which is to be vaporised is placed in the vaporising chamber in loose form. This is inconvenient, and furthermore, can lead to contamination of the combustion chamber by particles of the vaporisable matter adhering to the combustion chamber as well as tarry substances resulting from the vaporisation of the vaporisable matter adhering to the combustion chamber.

15 Additionally, it has been found that when a charge of some vaporisable matters, and in particular tobacco is being vaporised, the level of vapour of the vaporised constituent or constituents in the aerosol varies. In general, the level of such vapours rises from an initial relatively low level to the desirable level over time, and
20 then falls off gradually as the vaporisable matter becomes exhausted. This is undesirable, since in general, it is preferable that the level of the vapour of the vaporised constituent or constituents in the aerosol should be substantially constant during vaporisation of a charge of the vaporisable matter.

25 The present invention is directed towards providing a container of vaporisable matter for use in such vaporising devices, and in particular, for use in the heating device disclosed in PCT Published Application Specification No. WO 2006/082571 A1, which addresses at least some of the problems of known devices and methods for vaporising vaporisable matter. The invention is also directed towards a method for
30 producing an aerosol from vaporisable matter which addresses at least some of the problems of known methods and devices, and the invention is also directed towards a combination of the container and a vaporising device.

According to the invention there is provided a container defining a hollow interior region and having vaporisable matter in the hollow interior region, the container being adapted for locating in a vaporising chamber of a vaporising device, and being adapted for facilitating heat transfer from the vaporising device to the vaporisable matter for producing an aerosol of a vaporisable constituent of the vaporisable matter, the container comprising a first accommodating means for accommodating the carrier fluid into the hollow interior region, and a second accommodating means for accommodating the aerosol of the carrier fluid and vapour of the vaporisable constituent from the hollow interior region.

In one embodiment of the invention the container substantially defines the vaporising chamber. Preferably, the container is adapted to be a relatively tight fit in the vaporising chamber for facilitating heat transfer from the vaporising chamber to the container. Advantageously, the container is adapted to releasably engage the vaporising chamber.

In one embodiment of the invention the first accommodating means comprises an upstream inlet. Preferably, the upstream inlet is formed by an upstream opening. Advantageously, the first accommodating means comprises a first permeable means located in the upstream inlet.

In another embodiment of the invention the second accommodating means comprises a downstream outlet. Preferably, the downstream outlet is formed by a downstream opening. Advantageously, the second accommodating means comprises a second permeable means located in the downstream outlet.

In another embodiment of the invention the container extends between an upstream end and a downstream end, the first accommodating means being located adjacent the upstream end and the second accommodating means being located adjacent the downstream end. Preferably, the outer transverse cross-sectional area of the container intermediate the upstream and downstream ends thereof is substantially

similar to the inner transverse cross-sectional area of the vaporising chamber. Advantageously, the outer transverse cross-sectional area of the container intermediate the upstream and downstream ends thereof is just less than the inner transverse cross-sectional area of the vaporising chamber.

5

In one embodiment of the invention the container comprises a side wall which defines the hollow interior region, the side wall extending between the upstream end and the downstream end. Preferably, the side wall defines the upstream opening adjacent the upstream end, and the downstream opening adjacent the downstream
10 end. Advantageously, the upstream opening is closed by an upstream end cap. Ideally, the upstream end cap comprises the first accommodating means.

In another embodiment of the invention the upstream end cap is formed by the first permeable means.

15

In a further embodiment of the invention the downstream opening is closed by a downstream end cap. Preferably, the downstream end cap comprises the second accommodating means. Advantageously, the downstream end cap is formed by the second permeable means.

20

In another embodiment of the invention the side wall is of a heat conducting material.

In a further embodiment of the invention the side wall is of a paper based material.

25 In a still further embodiment of the invention the side wall is of cardboard material.

Alternatively, the side wall is of a foil material. Preferably, the side wall is of a metal foil.

30 In one embodiment of the invention a portion of the container is impermeable to the aerosol. Preferably, the portion of the container which is impermeable to the aerosol is also impermeable to the carrier fluid. Advantageously, the impermeable portion of

the container is located intermediate the first accommodating means and the second accommodating means. Ideally, the side wall forms the impermeable portion of the container.

- 5 In an alternative embodiment of the invention the side wall is of a gauze material. Preferably, the side wall is of a gauze of metal material.

In another embodiment of the invention the side wall of the container is adapted for engaging the vaporising chamber. Preferably, the side wall of the container is
10 adapted for engaging a corresponding side wall of the vaporising chamber.

Advantageously, the side wall of the container is adapted for engaging the corresponding side wall of the vaporising chamber with a heat transfer fit. Ideally, the side wall of the container is adapted for slideably engaging the corresponding
15 side wall of the vaporising chamber.

In one embodiment of the invention the side wall is of cylindrical construction.

In a further embodiment of the invention the second accommodating means
20 comprises an outlet tube extending from the container.

In one embodiment of the invention the second permeable means is located adjacent the outlet tube. Preferably, the second permeable means is located in the outlet tube. Advantageously, the second permeable means is in the form of a plug.
25

Advantageously, the outlet tube terminates in a mouthpiece. Preferably, a heat sink means is located in the outlet tube. Ideally, the heat sink means is located in the outlet tube intermediate the second permeable means and the mouthpiece.

30 In one embodiment of the invention the outlet tube is of transverse cross-section which is substantially similar to the transverse cross-section of the container.

In another embodiment of the invention the outlet tube is of circular transverse cross-section. In a further embodiment of the invention the outlet tube is of diameter which is similar to the diameter of the side wall of the container.

- 5 Ideally, the container is adapted for engaging the vaporising chamber with the outlet tube extending therefrom to provide access to the mouthpiece.

In one embodiment of the invention the downstream end cap is of an impermeable material, and defines an outlet opening. Preferably, the outlet tube extends from the
10 downstream end cap and communicates with the hollow interior region of the container through the outlet opening in the downstream end cap.

In a further embodiment of the invention the second permeable means is located adjacent the outlet opening in the downstream end cap.

15

In a further embodiment of the invention the container is adapted for accommodating a heat transfer member of the vaporising chamber into the hollow interior region of the container for transferring heat to the vaporisable matter contained therein. Preferably, the upstream end of the container is adapted for accommodating the
20 heat transfer member into the hollow interior region thereof. Advantageously, the upstream end cap is adapted for accommodating the heat transfer member into the hollow interior region.

In one embodiment of the invention a heat transfer member accommodating slit is
25 formed in the container for accommodating the heat transfer member therethrough to the hollow interior region thereof. Preferably, the heat transfer accommodating slit is formed in the upstream end cap. Advantageously, the heat transfer member accommodating slit is formed in the first permeable means.

30 In another embodiment of the invention the first permeable means comprises a first permeable material which is permeable to the carrier fluid.

In another embodiment of the invention the first permeable material is a paper based material.

In a further embodiment of the invention the first permeable material is a gauze.

5 Preferably, the first permeable material is a gauze of a metal material.

In a further embodiment of the invention the first permeable material is perforated.

10 In another embodiment of the invention the second permeable means comprises a second permeable material which is permeable to the aerosol of the carrier fluid and the vapour of the vaporisable constituent. Preferably, the second permeable material is a paper based material.

15 Alternatively, the second permeable material is a gauze. Preferably, the second permeable material is a gauze of a metal material.

In another embodiment of the invention the second permeable material is perforated.

20 In a still further embodiment of the invention the second permeable means comprises a filter medium. Preferably, the filter medium of the second permeable means is adapted for substantially inhibiting the passage of undesirable vapours from the aerosol passing therethrough. Advantageously, the filter medium of the second permeable means is adapted for substantially inhibiting the passage of tar and other undesirable fluids passing therethrough.

25 Preferably, the vaporisable matter contained in the hollow interior region of the container is in particulate form. Advantageously, the vaporisable matter contained in the hollow interior region is of particle size of maximum dimensions in the range of 50 microns to 5mm. Advantageously, the vaporisable matter is in strip form. Ideally,
30 the strips of the vaporisable matter are of maximum transverse dimensions in the range of 50 microns to 5mm. Preferably, the strips of the vaporisable matter are of length in the range of 5mm to 40mm.

In one embodiment of the invention the vaporisable matter contained in the hollow interior region comprises a blend of vaporisable matter of different strip sizes, and the strip sizes of the blend of the vaporisable matter are selected for maintaining the level of vapour of the vaporisable constituent in the aerosol substantially constant over the time period during which the vaporisable matter is being heated from the time the vaporisable matter is raised to a temperature suitable for vaporising the constituent until substantially all of the vapour has been evaporated from the vaporisable constituent.

10

In another embodiment of the invention the vaporisable matter contained in the hollow interior region comprises a blend of vaporisable matter of different particle sizes and different strip sizes, and the particle sizes and the strip sizes of the blend of the vaporisable matter are selected for maintaining the level of vapour of the vaporisable constituent in the aerosol substantially constant over the time period during which the vaporisable matter is being heated from the time the vaporisable matter is raised to a temperature suitable for vaporising the constituent until substantially all of the vapour has been evaporated from the vaporisable constituent.

In a still further embodiment of the invention the vaporisable matter contained in the hollow interior region comprises a blend of vaporisable matter of different particle sizes, and the particle sizes of the blend of the vaporisable matter are selected for maintaining the level of vapour of the vaporisable constituent in the aerosol substantially constant over the time period during which the vaporisable matter is being heated from the time the vaporisable matter is raised to a temperature suitable for vaporising the constituent until substantially all of the vapour has been evaporated from the vaporisable constituent.

In a still further embodiment of the invention the vaporisable matter contained in the hollow interior region of the container is selected from one or more of the following:

30

plant matter	herbs	tobacco
mullein	passion flower	cloves

yohimbe	mint	tea
eucalyptus	camomile.	

5 In one embodiment of the invention the vaporisable matter contained in the hollow interior region of the container is tobacco.

10 In a further embodiment of the invention the container is in the form of a sachet adapted for engagement in a plug portion of the vaporising chamber with the plug portion of the vaporising chamber in engagement with the vaporising chamber.

15 Additionally the invention provides a method for vaporising a vaporisable constituent of vaporisable matter to form an aerosol, the method comprising placing the vaporisable matter in a hollow interior region of a container comprising a first accommodating means for accommodating a carrier fluid into the hollow interior region and a second accommodating means for accommodating the aerosol from the hollow interior region, placing the container in a vaporising chamber of a vaporising device, heating the container and the vaporisable matter therein to a temperature at which the vaporisable constituent vaporises, and drawing a carrier fluid into the hollow interior region of the container through the first accommodating means and through the hollow interior region for entraining vapour of the vaporised constituent in the carrier fluid to form the aerosol and drawing the aerosol through the second accommodating means.

25 In one embodiment of the invention the temperature to which the vaporisable matter within the container is heated is varied for maintaining the level of the vaporisable constituent substantially constant in the aerosol over a time period from the time the vaporisable matter is raised to a temperature sufficient for vaporising the vaporisable constituent until substantially all the vapour has been evaporated from the vaporisable constituent.

30 The invention also provides a vaporising device comprising a vaporising chamber and a heat source for heating the vaporising chamber, and a container according to

the invention located in the vaporising chamber, the vaporising chamber having a carrier fluid inlet for facilitating drawing of a carrier fluid into the hollow interior region of the container through the first permeable means for entraining vapour of a vaporisable constituent of the vaporisable matter in the carrier fluid to form an aerosol of the carrier fluid and the vapour of the vaporisable constituent, so that the aerosol can be drawn from the hollow interior region of the container through the second permeable means.

The advantages of the invention are many. By virtue of the fact that the vaporisable matter is provided in a container which is suitable for locating in a vaporising chamber of a vaporising device, the vaporisable matter contained in the container can be factory selected and thus selected under controlled conditions and factory packed into the container also under controlled conditions. Thus the consistency and/or blending and other properties of the vaporisable matter, such as moisture content, weight and the proportions of other ingredients and additives to the vaporisable matter in the container can be accurately controlled under factory conditions. Accordingly, the consistency and blend as well as such other properties of the vaporisable matter can be selected and controlled so that the level of the vapour of the vaporisable constituent or constituents in the aerosol remains substantially constant during vaporisation of the vaporisable matter.

A further advantage of providing the vaporisable matter in a container which is suitable for locating in a vaporising chamber of a heating device is that the vaporisable matter does not come into direct contact with the vaporising chamber, and thus, the risk of contamination, soiling or otherwise damaging the vaporising chamber is avoided.

By providing a first permeable means which is permeable to the carrier fluid and a second permeable means which is permeable to the aerosol, namely, the carrier fluid with the vapour of the vaporisable constituent contained therein, more accurate control of the amount and quality of the carrier fluid being drawn into the hollow interior region of the container can be achieved. Furthermore, by providing the

second permeable means for accommodating the aerosol from the hollow interior region of the container permits the rate and quality of the aerosol being drawn from the hollow interior region of the container to be also more accurately controlled. Indeed, where the second permeable means is provided by a filter, the passage of
5 undesirable constituents in the aerosol through the filter can be substantially inhibited, and thus removed from the aerosol, thereby providing a relatively pure aerosol uncontaminated by undesirable vapours from other vaporisable constituents of the vaporisable matter. By controlling the rate at which the carrier fluid is drawn into the hollow interior region of the container and the rate at which the aerosol is
10 being drawn out of the hollow interior region, more accurate control of the level of the vaporised constituent or constituents in the aerosol can be achieved.

Furthermore, by appropriately selecting the first and second permeable means, the pressure drop which is required to be applied by a user during drawing on the
15 mouthpiece in order to draw the aerosol from the hollow interior region of the container can be minimised.

Additionally, by factory controlling the content of the vaporisable matter in the container, and factory packing of the vaporisable matter into the container, the level
20 of the vaporised constituent or constituents can be readily controlled, and thus, the level of vapour of the vaporisable constituent or constituents in the aerosol during production of the aerosol can be readily controlled.

By producing the vaporisable matter as a blend of matter of particles of different
25 sizes, and/or strips of different sizes, so that the surface area of the vaporisable matter is maximised, more accurate control of the level of the vaporised constituent or constituents in the aerosol during production of the aerosol can be achieved. In particular, by providing the vaporisable matter as a blend of particles of different sizes of maximum dimensions within a range of 50 microns and 5mm, and
30 furthermore, by providing some or all of the particles in the form of strips of maximum transverse cross-sectional dimensions in the range of 50 microns to 5mm and of length in the range of 5mm to 40mm, it has been found that particularly

accurate control of the level of the vapour of the vaporisable constituent or constituents in the aerosol during production of the aerosol can be controlled within relatively tight limits, and in particular, the level of the vapour of the vaporisable constituent or constituents in the aerosol can be maintained substantially constant
5 during vaporisation of a charge of the vaporisable matter in the container during production of the aerosol therefrom.

The invention will be more clearly understood from the following description of some preferred embodiments thereof, which are given by way of example only, with
10 reference to the accompanying drawings, in which:

Fig. 1 is a perspective view of a sachet according to the invention of tobacco for use in a gas powered vaporising device for vaporising vaporisable constituents in the tobacco to form an aerosol thereof,

15

Fig. 2 is an exploded perspective view of the sachet of Fig. 1,

Fig. 3 is a perspective view of the gas powered vaporising device,

20

Fig. 4 is a transverse cross-sectional side elevational view of the vaporising device of Fig. 3,

Fig. 5 is a side elevational view of a portion of the vaporising device of Fig. 3,

25

Fig. 6 is a transverse cross-sectional view of the portion of Fig. 5 of the vaporising device of Fig. 3 on the line VI-VI of Fig. 5,

Fig. 7 is a perspective view of a portion of the vaporising device of Fig. 3,

30

Fig. 8 is a perspective view of another portion of the vaporising device of Fig. 3,

Fig. 9 is a partly cutaway perspective view of the portion of Fig. 8 of the vaporising device of Fig. 3,

5 Fig. 10 is a transverse cross-sectional side elevational view of a portion of the device of Fig. 3 illustrating the sachet of Fig. 1 located in a vaporising chamber thereof,

10 Fig. 11 is a perspective view of a sachet according to another embodiment of the invention of tobacco,

Fig. 12 is an exploded perspective view of the sachet of Fig. 11,

15 Fig. 13 is a perspective view of a sachet according to a further embodiment of the invention of tobacco,

Fig. 14 is an exploded perspective view of the sachet of Fig. 13,

20 Fig. 15 is a perspective view of a sachet according to a still further embodiment of the invention of tobacco,

Fig. 16 is an exploded perspective view of the sachet of Fig. 15,

25 Fig. 17 is a perspective view of a container also according to the invention of tobacco for use in the vaporising device of Fig. 3,

Fig. 18 is another perspective view of the container of Fig. 17,

30 Fig. 19 is a transverse cross-sectional side elevational view of the container of Fig. 17,

Fig. 20 is a perspective view of a container according to another embodiment of the invention of tobacco for use in a vaporising device substantially similar

to that of Fig. 3,

Fig. 21 is a transverse cross-sectional side elevational view of the container of Fig. 20,

5

Fig. 22 is a transverse cross-sectional view of a portion of a vaporising device, which is substantially similar to the vaporising device of Fig. 3 illustrating the container of Fig. 20 located therein,

10

Fig. 23 is a perspective view of a container according to a further embodiment of the invention of tobacco for use in the vaporising device, the portion of which is illustrated in Fig. 22, and

15

Fig. 24 is a perspective view of a portion of the vaporising device according to another embodiment of the invention.

Referring to the drawings and initially to Figs. 1 to 10, there is illustrated a container according to the invention, which in this embodiment of the invention is provided by a sachet, indicated generally by the reference numeral 1, containing vaporisable matter, in this case, tobacco 2 for placing in a vaporising chamber of a vaporising device for vaporising vaporisable constituents in the tobacco 2, for example, nicotine and other desirable constituents to produce an aerosol. The sachet 1 according to this embodiment of the invention is disposable, is pre-packed with the tobacco 2, and is particularly suitable for use with the vaporising device disclosed in PCT published Application Specification No. WO 2006/082571 A1 (which is incorporated herein by reference) for placing in a vaporising chamber thereof in which the aerosol is produced. Before describing the sachet 1 in further detail, the relevant components of the vaporising device disclosed in PCT published Application Specification No. WO 2006/082571 will be briefly described.

30

Referring in particular to Figs. 3 to 10, the vaporising device is indicated generally by the reference numeral 5 and is a portable handheld device which comprises a two-

part casing 6 of plastics material. An elongated main housing 9 of suitable heat conducting metal materials is located in the housing 5, and a combustion chamber 10 is formed in the main housing 9 wherein a fuel gas/air mixture is converted to heat by a gas catalytic combustion element 12. Exhaust gases from the combustion chamber 10 are exhausted through an exhaust gas chamber 13 located downstream of the combustion chamber 10, and in turn through exhaust gas ports 14. A vaporising chamber 15 within which vaporisable matter is vaporised is located downstream of the exhaust gas chamber 13, and heat from the combustion chamber 10 and the exhaust gas chamber 13 is transferred into a vaporising chamber 15 for vaporising the vaporisable matter therein.

The vaporising chamber 15 comprises a socket portion 16 which is formed by a cylindrical socket side wall 17 extending downstream from the exhaust gas chamber 13 and a hollow plug portion 18 which is formed by a cylindrical plug side wall 20 which extends from a downstream end cap 21. The plug portion 18 is of a suitable heat conducting metal, and is releasably engageable in the socket portion, and the plug side wall 20 engages the socket side wall 17 with a snug sliding fit for facilitating heat transfer from the socket side wall 17 to the plug side wall 20. The plug side wall 20 and the downstream end cap 21 define a hollow interior region 22, which when the plug portion 18 is located in the socket portion 16 forms the vaporising chamber 15. An upstream end of the plug side wall 20 defines an open mouth 24 to the hollow interior region 22, and a transversely extending end wall 23 in the socket portion 16 closes the open mouth 24 when the plug portion 18 is fully engaged in the socket portion 16.

Heat is transferred by conduction through the main housing 9 from the combustion chamber 10, the exhaust gas chamber 13, the socket side wall 17 and the plug side wall 20 into the vaporising chamber 15 for vaporising vaporisable matter located in the hollow interior region 22 of the plug portion 18. Additional heat is also transferred from the exhaust gas chamber 13 through a heat transfer member 25 of a suitable heat conducting metal material which extends centrally into the socket portion 16 from the exhaust gas chamber 13, and in turn into the hollow interior

region 22 of the plug portion 18 when the plug portion 18 is engaged in the socket portion 16. The heat transfer member 25 terminates in a pointed tip 26 for engaging and piercing the sachet 1 as will be described in more detail below.

5 An outlet opening 28 in the downstream end cap 21 of the plug portion 18 accommodates the aerosol from the vaporising chamber 15 into an outlet tube 29 which accommodates the aerosol to a mouthpiece 30 through which the aerosol is drawn into the mouth of a subject and inhaled. A heat sink element 31 is located in the outlet tube 29 for cooling the aerosol and condensing tarry constituents entrained
10 therein prior to being drawn through the mouthpiece 30. An air inlet port 32 into the main housing 9 and air accommodating openings 33 in the end wall 23 accommodate air into the vaporising chamber 15. In this embodiment of the invention air is a carrier fluid in which vapours vaporised from the vaporisable constituents of the vaporisable matter in the vaporising chamber 15 are entrained for
15 producing the aerosol.

Fuel gas, in this embodiment of the invention a mixture of butane and propane in liquid form, in which the butane predominates is stored in a rechargeable reservoir 34 in the casing 6 and is delivered through an isolating switch 35 and a pressure
20 regulator (not shown) from the reservoir 34 through a supply pipe 36 to a temperature responsive safety isolating valve 37. The fuel gas from the temperature responsive safety isolating valve 37 is supplied to a temperature responsive control valve 38 for controlling the supply of fuel gas to the combustion chamber 10, for in turn controlling the temperature of the vaporising chamber 15. The fuel gas from the
25 temperature responsive control valve 38 is mixed with air in a venturi mixer 39, and the fuel gas/air mixture from the venturi mixer 39 is delivered into the combustion chamber 10 where it is converted to heat by the gas catalytic combustion element 12. A detailed description of the vaporising device 5 and its operation is given in published PCT Application Specification No. WO 2006/082571 A1.

30

Referring now to Figs. 1 and 2, the sachet 1 comprises a cylindrical side wall 45 of an impermeable material which is impermeable to both the aerosol and the carrier

fluid, namely, air in which vapours of the vaporisable constituents are entrained to produce the aerosol. In this embodiment of the invention the cylindrical side wall 45 is of a paper based material, and typically, is of paper of the type used for rolling a cigarette. The side wall 45 defines a hollow interior region 46 within which the tobacco 2 is contained. An upstream end 47 of the side wall 45 defines a first accommodating means, namely, an upstream opening 48 for accommodating the carrier fluid, namely, air into the hollow interior region 46. A downstream end 50 of the side wall 45 defines a second accommodating means, namely, a downstream opening 52 for accommodating the aerosol from the hollow interior region 46. A first permeable means, which is permeable to air, comprising a first permeable membrane 51 extends across the upstream opening, and forms an upstream end cap 49 through which air is accommodated into the hollow interior region 46. A second permeable means, which is permeable to the aerosol, comprising a second permeable membrane 54 extends across the downstream opening 52 and forms a downstream end cap 53 through which the aerosol is drawn from the hollow interior region 46. The upstream and downstream end caps 49 and 53 are sealably secured to the side wall 45 of the sachet 1 by a suitable adhesive. Air, which is the carrier fluid, is accommodated into the hollow interior region 46 through the upstream end cap 49 from the air inlet port 32 in the main housing 9 and the air accommodating openings 33 in the end wall 23 of the vaporising chamber 15. The aerosol, which comprises air with the vapour or vapours of the vaporisable constituent or constituents of the tobacco 2 entrained therein is accommodated from the hollow interior region 46 through the downstream end cap 53 and in turn through the outlet opening 28 in the downstream end cap 21 of the plug portion 18.

In this embodiment of the invention the first and second permeable membranes 51 and 54 of the upstream and downstream end caps 49 and 53, respectively, are of similar permeable materials. Both are of a porous paper material of thickness of the order of 100 microns formed of fibres of approximately 10 microns diameter. The paper material of the upstream and downstream end caps 49 and 53 is of porosity to be sufficiently permeable to air and to the aerosol, while at the same time retaining the tobacco 2 within the hollow interior region 46 of the sachet 1 for preventing

particles of tobacco 2 and contaminants, such as tar and the like contaminating the vaporising chamber 15.

The paper material of the upstream and downstream end caps 49 and 53 is
5 relatively easily pierceable, so that when the sachet 1 is located in the hollow interior region 22 of the plug portion 18 and the plug portion 18 is being engaged in the socket portion 16 of the vaporising device 1, the upstream end cap 49 is readily easily pierced by the heat transfer member 25, so that in use the heat transfer member 25 extends into the hollow interior region 46 of the sachet 1 for directly
10 transferring heat into the tobacco 2. The paper material of the upstream and downstream end caps 49 and 53 is also of the type which effectively self-seals, so that once pierced by the heat transfer member 25, the paper material of the upstream end cap 49 self-seals around the heat transfer member 25, thereby preventing loss of particles of tobacco 2 and other contaminants from the hollow
15 interior region 46 of the sachet 1. The sealing action of the paper material of the upstream end cap 49 on the heat transfer member 25 also has a cleansing action on the heat transfer member 25 as the sachet 1 is being disengaged from the heat transfer member 25, thereby removing tobacco particles and tarry contaminants from the heat transfer member 25.

20 The sachet 1 substantially defines the internal volume of the vaporising chamber 15 of the vaporising device 5, and the side wall 45 of the sachet 1 is of outer diameter just less than the internal diameter of the plug side wall 20 of the plug portion 18, and is of length substantially similar to the length of the plug side wall 20 from the
25 downstream end cap 21 to the open mouth 24. Thus, the sachet 1 forms a releasable, relatively snug, tight fit in the hollow interior region 22 of the plug portion 18, so that when the plug portion 18 is fully engaged in the socket portion 16, heat is efficiently transferred from the socket side wall 17 through the plug side wall 20 and the side wall 45 of the sachet 1 to the tobacco 2.

30 The tobacco 2 in this embodiment of the invention is in both particulate form and strip form and comprises a blend of tobacco particles and strips of different sizes.

The particles of the different particle size in the blend of particle sizes are of size such that the maximum dimension of the particles is in a range from 50 microns to 5mm. The strips of the different sizes are of length in the range of 5mm to 40mm and of maximum transverse cross-sectional dimensions in the range of 50 microns to 5mm. The different sizes of the particles and strips of the blend of particles and strips of the tobacco 2 are selected to optimise the surface area of the particles and strips consistent with vaporising the vaporisable constituents of the tobacco 2, so that the level of vapour of the vaporised constituents in the aerosol is substantially constant from the time the tobacco 2 has been brought up to the vaporisation temperature of the vaporisable constituents to be vaporised until those vaporisable constituents in the tobacco 2 have been exhausted. It has been found that by providing the tobacco in particulate form and strip form, and of particles of different sizes appropriately sized and with the maximum dimensions of the particles within the range of 50 microns to 2mm and with the strips of different sizes and appropriately sized of lengths in the range of 5mm to 40mm and of maximum transverse cross-sectional dimensions in the range of 50 microns to 5mm, enhances the rate of vaporisation of the vaporisable matter, particularly at the initial stages after the tobacco has been brought up to the vaporisation temperature of the vaporisable constituents to be vaporised. Additionally, by so providing the tobacco 2 of such particle and strip sizes, vapours are more efficiently released from the vaporisable constituent, and thus a relatively sharp cut-off of the evaporation of the vapours of the vaporisable constituents of the tobacco 2 occurs as the vaporisable constituents are being exhausted. This, thus, provides an aerosol which is more consistent over the period during which the vaporisable constituents of the tobacco 2 in the sachet 1 are being vaporised, and in particular, assists in maintaining the level of the vapours of the vaporisable constituents in the aerosol substantially constant from the time the tobacco 2 is brought up to the vaporisation temperature until substantially all of the vaporisable constituents to be vaporised.

In use, the sachet 1 pre-packed with the tobacco 2 is placed in the hollow interior region 22 of the plug portion 18 with the downstream end cap 53 of the sachet 1 abutting the downstream end cap 21 of the plug portion 18. The plug portion 18 is

then engaged in the socket portion 16 of the vaporising device 5, and is urged fully home into the socket portion 16 with the upstream end cap 49 of the sachet 1 abutting the upstream end wall 23 of the socket portion 16. As the plug portion 18 is being urged into the socket portion 16, the upstream end cap 49 of the sachet 1 is pierced by the pointed tip 26 of the heat transfer member 25, and further urging of the plug portion 18 into the socket portion 16 urges the heat transfer member 25 into the hollow interior region 46 of the sachet 1 for transferring heat directly to the tobacco 2.

10 With the plug portion 18 of the vaporising chamber 15 engaged in the socket portion 16, the vaporising device 5 is operated for delivering fuel gas/air mixture into the combustion chamber 10 where the fuel gas/air mixture is initially ignited to burn in a flame to raise the gas catalytic combustion element 12 to its ignition temperature. Thereafter, the gas catalytic combustion element 12 converts the fuel gas/air mixture to heat. In this embodiment of the invention the temperature responsive control valve 38 is preset to control the temperature of the main housing 9 of the vaporising device 5 at a temperature so that the temperature within the vaporising chamber 15 and in turn the temperature of the tobacco 2 is maintained at a temperature of approximately 160°C, which is the optimum temperature for vaporising the desirable vaporisable constituents in the tobacco.

Once the tobacco 2 in the sachet 1 in the combustion chamber 15 has been brought up to the vaporising temperature of 160°C, the vaporisable constituents of the tobacco 2 commence to vaporise. By drawing on the mouthpiece 30 of the vaporising device 5, air is drawn into the vaporising chamber 15 and in turn into the hollow interior region 46 of the sachet 1 through the upstream end cap 49. Vapours of the vaporised constituents are entrained in the air in the hollow interior region 46 to form the aerosol. The aerosol is drawn through the outlet opening 28 in the downstream end cap 21 of the plug portion 18 and in turn into the outlet tube 29 and through the mouthpiece 30. The aerosol is cooled as it passes over the heat sink 31 in the outlet tube 29, and tarry substances in the aerosol condense onto the heat sink 31.

In practice, it is envisaged that the vaporising chamber 15 and the sachet 1 will be of size suitable for containing a sufficient quantity of tobacco 2 to produce between six and twelve puffs.

5

When the tobacco 2 in the sachet 1 is spent, the sachet is removed from the combustion chamber 15, and is replaced with a fresh sachet 1 of tobacco 2.

Referring now to Figs. 11 and 12, there is illustrated a disposable sachet 60 according to another embodiment of the invention of tobacco 2 for use with the vaporising device 5. The sachet 60 is substantially similar to the sachet 1, and similar components are identified by the same reference numerals. The main difference between the sachet 60 and the sachet 1 is that the cylindrical side wall 45 of the sachet 60 is of metal gauze material, and is thus not impermeable, and the upstream and downstream end caps 49 and 53 are of a similar metal gauze material to that of the side wall 45. Being of a gauze material, the upstream end cap 49 and the downstream end cap 53 are permeable to air and the aerosol. Since the upstream end cap 49 is of metal gauze material, a heat transfer member accommodating slit 61 is provided in the upstream end cap 49 for accommodating the heat transfer member 25 into the hollow interior region 46 of the sachet 60. As the plug portion 18 with the sachet 60 located therein is being engaged in the socket portion 16 of the vaporising device 5, the pointed tip 26 of the heat transfer member 25 engages the slit 61, thereby opening the slit 61 to accommodate the heat transfer member 25 into the hollow interior region 45 of the sachet 60.

25

Otherwise, the sachet 60 and its use in the vaporising device 5 is similar to that already described with reference to the sachet 1.

Referring now to Figs. 13 and 14, there is illustrated a disposable sachet 65 also according to the invention of tobacco 2 for use with a vaporising device substantially similar to the vaporising device 5. The sachet 65 is substantially similar to the sachet 1 and similar components are identified by the same reference numerals.

30

The main difference between the sachet 65 and the sachet 1 is in the side wall 45 thereof. The side wall 45 is of similar material to the side wall 45 of the sachet 1, as are the upstream and downstream end caps 49 and 53 thereof of a similar material to that of the upstream and downstream end caps 45 and 53 of the sachet 1.

5 However, in this embodiment of the invention the side wall 45 is shaped at 66 to form longitudinally extending recesses 67 for accommodating heat exchange projections extending from the plug side wall 20 of the plug portion 18 into the hollow interior region 22 thereof for enhancing heat transfer from the plug portion 18 to the sachet 65 and in turn to the tobacco 2 therein. The heat exchange projections on
10 the plug side wall 20 for engaging the shaped portions 66 of the sachet 65 are not illustrated, however, their construction and shape is complementary to the shape of the recesses 67 of the sachet 65, and will be readily apparent to those skilled in the art.

15 Otherwise the sachet 65 and its use in conjunction with the vaporising device 5 is similar to the sachet 1 already described.

Referring now to Figs. 15 and 16, there is illustrated a disposable sachet 70 according to a still further embodiment of the invention of tobacco 2 for use in a
20 vaporising device substantially similar to the vaporising device 5. In this embodiment of the invention, it is envisaged that the heat transfer member 25 of the heating device 5 will be omitted. The sachet 70 is substantially similar to the sachet 1, and similar components are identified by the same reference numerals. The main difference between the sachet 70 and the sachet 1 is that a tubular heat transfer
25 element 71 is located within the hollow interior region 46 of the sachet 70 adjacent the upstream end cap 49, and extends into the hollow interior region 46 from the upstream end cap 49. An opening 72 in the upstream end cap 49 exposes the heat transfer element 71. The heat transfer element 71 engages and co-operates with the upstream end wall 23 of the socket portion 16 for enhancing heat transfer into
30 the tobacco 2 in the sachet 70. Ideally, though not essential, the heat transfer element 71 may be of a magnetic material, so that the heat transfer element 71 is drawn towards and tightly abuts the upstream end wall 23 of the socket portion 16 by

magnetic attraction. In this embodiment of the invention the side wall 45 is of aluminium foil, and the upstream and downstream end caps 49 and 53 are of perforated aluminium foil.

- 5 Otherwise, the sachet 70 and its use in the vaporising device 5 is similar to the sachet 1.

However, it is envisaged that in certain cases the internal diameter of the heat transfer element 71 may be just greater than the outer diameter of the heat transfer member 25, and the vaporising device would be provided with the heat transfer member 25, so that the heat transfer element 71 would be a snug sliding fit on the heat transfer member 25 for transferring heat from the heat transfer member 25 to the heat transfer element 71, and in turn to the tobacco 2.

- 15 Referring now to Figs. 17 to 19, there is illustrated a disposable container according to another embodiment of the invention, indicated generally by the reference numeral 75, of tobacco 2 for use in conjunction with the vaporising device 5 described with reference to Figs. 3 to 9 for vaporising the tobacco 2 contained in the container 75. In this embodiment of the invention the container 75 instead of being
20 formed by a sachet is shaped in the form of the plug portion 18 of the vaporising device 5, and also comprises an outlet tube 76 extending from the container 75 and terminating in a mouthpiece 77. In this embodiment of the invention the container 75 replaces the plug portion 18 and the outlet tube 29 of the vaporising device 5. The container 75 comprises a cylindrical side wall 78 which defines a hollow interior
25 region 79 for the tobacco 2, and which is of similar outer diameter to that of the plug side wall 20 of the plug portion 18 for releasably engaging the socket side wall 17 of the socket portion 16 with a snug sliding fit for facilitating heat transfer by conduction between the socket side wall 17 and the side wall 78 of the container 75. The length of the side wall 78 of the container 75 is similar to the length of the plug side wall 20
30 of the plug portion 18. In this embodiment of the invention the material of the side wall 78 is impermeable to air and to the aerosol, and is of a suitable plastics material. An upstream end 80 of the side wall 78 is closed by an upstream end cap

81 of a first material which is permeable to air, which in this case is porous paper material. A downstream end 82 of the side wall 78 is closed by a downstream end cap 83 of similar impermeable plastics material to that of the side wall 78. The outlet tube 76, which is also of a similar plastics material to that of the side wall 78, extends
5 from the downstream end cap 83. An outlet opening 84 in the downstream end cap 83 communicates the outlet tube 76 with the hollow interior region 79 of the container 75.

In this embodiment of the invention the second permeable means is provided by a
10 filter 85 of a filter medium which is formed into a plug which is engaged in the outlet tube 76 adjacent the outlet opening 84 in the downstream end cap 83. The material of the filter 85 is of a material suitable for substantially inhibiting the passage of tarry substances and undesirable vapours in the aerosol therethrough.

15 A heat sink element 86 similar to the heat sink element 31 of the vaporising device 5 is located in the outlet tube 76 intermediate the filter 85 and the mouthpiece 77.

In use, since the container 75 replaces the plug portion 18 of the vaporising device 5, the plug portion and the outlet tube 29 are no longer required, and may be
20 dispensed with. Thus, with the container 75 engaged and fully home in the socket portion 16 of the vaporising device 5, the vaporising device 5 is ready for use. With the temperature of the tobacco 2 in the container 75 raised to approximately 195°C by the vaporising device 5, a subject draws on the mouthpiece 77 of the outlet tube 76, thereby drawing an aerosol of the vapours of the vaporisable constituents of the tobacco 2 from the hollow interior region 79 of the container 75 through the outlet
25 tube 76, and in turn through the mouthpiece 77. Air is drawn into the hollow interior region 79 of the container 75 through the air accommodating openings 33 in the upstream end wall 23 and in turn through the upstream end cap 81. The vaporised constituents are entrained in the air as it is being drawn through the hollow interior
30 region 79 to form the aerosol, and tarry substances and other undesirable vaporised constituents are filtered from the aerosol as it is drawn through the filter 85.

Otherwise, the container 75 and its use in conjunction with the vaporising device 5 is similar to that of the sachet 1.

Referring now to Figs. 20 to 22, there is illustrated a disposable container according to another embodiment of the invention, indicated generally by the reference numeral 90, of tobacco 2 for use in conjunction with the vaporising device 5 described with reference to Figs. 3 to 9 for vaporising the tobacco 2 contained in the container 90. As in the case of the container 75, the plug portion 18 of the vaporising device 5 is not required for vaporising the vaporisable constituents of the tobacco 2 in the container 90. The container 90 comprises a cylindrical side wall 91 of paper, similar to that used in rolling a cigarette. The side wall 91 defines a hollow interior region 92 for the tobacco 2, and an upstream end cap 93 extends across an upstream opening 94, and is sealably secured to the side wall 91. The upstream end cap 93 is of a first permeable material, which in this case is a porous paper material similar to that of the upstream end cap 49 of the sachet 1 which is described with reference to Figs. 1 and 2, for accommodating a carrier fluid, namely, air, which subsequently forms the aerosol, into the hollow interior region 92. The outside diameter of the socket side wall 91 is just less than the internal diameter of the side wall 17 of the socket portion 16 of the vaporising device 5 so that the side wall 91 is a relatively tight sliding fit in the vaporising chamber 15 for maximising heat transfer from the socket side wall 17 of the socket portion 16 to the tobacco 2. The length of the side wall 91 is substantially similar to the axial length of the socket side wall 17 of the socket portion 16.

A downstream opening 95 defined by the side wall 91 at a downstream end 96 accommodates the aerosol from the hollow interior region 92. An outlet tube 97 extends from the side wall 91 at the downstream end 96 thereof for accommodating the aerosol from the hollow interior region 92, and in this embodiment of the invention the outlet tube 95 is formed by a filter accommodating cylindrical side wall 98 of a relatively stiff paper material which is suitable for withstanding moisture from the mouth of a user. The diameter of the filter accommodating side wall 98 is substantially similar to the diameter of the side wall 91, and the filter accommodating

side wall 98 overlaps the side wall 91 at the downstream end 96 thereof, where it is secured to the side wall 91 by a suitable adhesive.

In this embodiment of the invention the second permeable means is provided by a filter 99 which is located within the filter accommodating side wall 98 and extends through the filter accommodating side wall 98 from the downstream opening 95 defined by the side wall 91. The filter 99 is of similar material to the filter 85 of the container 75. In effect, the container 90 according to this embodiment of the invention is in the form of a stubby cigarette which is closed at its upstream end by the upstream end cap 93.

In use, as discussed above, the plug portion 18 of the vaporising device 5 is not required. The container 90 with the tobacco 2 therein is engaged in the vaporising chamber 15 defined by the socket portion 16 by sliding the side wall 91 into the vaporising chamber 15 with the side wall 91 in relatively tight sliding engagement with the side wall 17 of the socket portion 16. The container 90 is urged into the vaporising chamber 15 until it is fully home in the vaporising chamber 15, and typically, when the container 90 is fully home in the vaporising chamber 15, the filter accommodating side wall 98 adjacent the downstream end of the side wall 91 abuts the socket side wall 17 of the socket portion 16 of the vaporising device. As the container 90 is being inserted into the vaporising chamber 15, the upstream end cap 93 is pierced by the pointed tip 26 of the heat transfer member 25, and further urging of the container 90 into the vaporising chamber 15 causes the heat transfer member 25 to extend into the hollow interior region 92 of the container 90 for engaging and transferring heat to the tobacco 2 therein.

The vaporising device is operated to raise the temperature within the vaporising chamber 15 and in turn the temperature of the tobacco 2 to the desired vaporising temperature of 160°C. A user then places the lips of his or her mouth around the filter accommodating side wall 98 and draws the aerosol from the hollow interior region 92 through the filter 99. When the tobacco 2 in the container 90 has been exhausted, the container 90 is replaced with a fresh container 90 in the vaporising

chamber 15.

Referring now to Fig. 23, there is illustrated a disposable container, according to another embodiment of the invention, indicated generally by the reference numeral 100 of tobacco 2. The container 100 is substantially similar to the container 90 which has been described with reference to Figs. 20 to 22, and similar components are identified by the same reference numerals. The only difference between the container 100 and the container 90 is that in the container 100 the upstream end cap 93 has been omitted, and the tobacco within the hollow interior region 92 of the container 100 is therefore exposed through the upstream opening 94. The container 100 is dimensioned similarly as the container 90 so that the side wall 91 of the container 100 is a relatively tight sliding fit in the vaporising chamber 15 of the vaporising device 5. Otherwise, the container 100 and its use is similar to that described with reference to the container 90.

Referring now to Fig. 24, there is illustrated a socket portion 16 of a vaporising device according to another embodiment of the invention. Both the vaporising device and the socket portion 16 of this embodiment of the invention are substantially similar to the vaporising device 5 and the socket portion 16 of the vaporising device 5, and similar components are identified by the same reference numerals. The main difference between the two vaporising devices is in the socket portion 16. In this case, instead of a single centrally located heat transfer member 25 extending from the upstream end wall 23 into the socket portion 16, four heat transfer members 25 are provided. The heat transfer members 25 are similar to the heat transfer member 25 of the socket portion 16 of the vaporising device 5, and extend from the exhaust gas chamber 13 through the upstream end wall 23, and are located at equi-spaced apart intervals circumferentially around the centre of the upstream end wall 23. Otherwise, the socket portion 16 and the vaporising chamber 15 of the vaporising device according to this embodiment of the invention are similar to the socket portion 16 and the vaporising chamber 15 of the vaporising device 5.

Where sachets and containers similar to the sachets and containers described

herein are to be provided for use with the socket portion 16 illustrated in Fig. 24, the sachets and containers will be substantially similar to those described hereinabove, with the exception that where heat transfer member accommodating slits are required in the upstream end cap of the sachets or containers, four heat transfer
5 accommodating slits will be provided appropriately positioned for engaging the pointed tips 26 of the respective heat transfer members 25.

While the downstream end caps of some of the sachets have been described as being of a paper based material, which is permeable to the aerosol, it is envisaged in
10 certain cases that the downstream end caps may be of a filter material for filtering out undesirable constituents, vaporised or otherwise, which would be entrained in the aerosol, for example, for filtering out tarry substances and other undesirable constituents. Such filter material may, but not necessarily, be of material similar to the filter 85 of the container 75. Where the downstream end cap is provided of a
15 filter material, it is envisaged that the downstream end cap will be in the form of a cylindrical plug, which would be engaged in the downstream opening defined by the side wall of the sachets, in order to provide sufficient filtering of the aerosol. Such a filter could be of the type provided on a filter tipped cigarette.

20 While not illustrated, it is envisaged that the sachets may be provided with a tab adjacent the downstream end thereof for facilitating removal of a spent sachet from the vaporising chamber.

While the sachets and containers have been described as containing tobacco, the
25 sachets and containers may be provided with any other vaporisable matter, which includes one or more vaporisable constituents which are to be vaporised.

While the sachets and containers according to the invention have been described for use with a gas powered heating device, it is envisaged that the sachets may be
30 provided for use in conjunction with a heating device heated by any other suitable heating source, for example, by an electrically powered heating source or the like.

While the sachets and container have been described as being of cylindrical shape, the sachets and container may be of any other suitable or desirable shape. While it is desirable that the sachet should define the interior of the vaporising chamber, this is not essential. However, it is desirable that there should be a relationship between
5 the sachet and the interior of the vaporising chamber to optimise the amount of air drawn through the sachet and in turn through the tobacco in order to produce a desirable aerosol of the vaporised constituents.

Additionally, it will be appreciated that the upstream and downstream end caps
10 which form the first and second permeable means, respectively, may be permeable to other fluids, including vapours, gases and the like besides the carrier fluid, which in general will be air, and the aerosol.

While the sachets and container have been described as being of specific types of
15 materials, the sachets and container may be of any other suitable materials, and the materials of the first and second permeable means may be of any suitable material which would permit air to be drawn into the hollow interior region of the sachet, and the aerosol to be drawn therefrom. Indeed, in some embodiments of the invention it is envisaged that the side wall of the sachet may be of a wire gauze material, while
20 the upstream and downstream end caps may be of a suitable paper or other such permeable material. Needless to say, the first and second permeable materials may be the same or different. It is also envisaged that the materials of the first and second permeable means and the side wall may be similar materials.

25 Additionally, in some embodiments of the invention it is envisaged that the vaporising device may be adapted for facilitating altering of the temperature of the device for varying the temperature of the tobacco in the sachet for assisting in maintaining the level of vaporised matter substantially constant in the aerosol from the time the tobacco has been brought up to the vaporising temperature until the
30 tobacco or other vaporisable matter has been exhausted.

It will be appreciated that while the vaporising device has been described as

maintaining the temperature of the tobacco at 160°C for vaporising the vaporisable constituents, this temperature may vary, depending on the type of tobacco used. It will also be appreciated that where the vaporisable matter is vaporisable matter other than tobacco, the vaporising device will be operated for maintaining the

5 temperature of the vaporisable matter at an appropriate temperature for vaporising the vaporisable constituents therein. For example, it is envisaged that where the vaporisable matter is camomile, a suitable vaporising temperature would be of the order of 195°C.

Claims

1. A container defining a hollow interior region and having vaporisable matter in the hollow interior region, the container being adapted for locating in a vaporising chamber of a vaporising device, and being adapted for facilitating heat transfer from the vaporising device to the vaporisable matter for producing an aerosol of a vaporisable constituent of the vaporisable matter, the container comprising a first accommodating means for accommodating the carrier fluid into the hollow interior region, and a second accommodating means for accommodating the aerosol of the carrier fluid and vapour of the vaporisable constituent from the hollow interior region.
2. A container as claimed in Claim 1 in which the container substantially defines the vaporising chamber.
3. A container as claimed in Claim 1 or 2 in which the container is adapted to be a relatively tight fit in the vaporising chamber for facilitating heat transfer from the vaporising chamber to the container.
4. A container as claimed in any preceding claim in which the container is adapted to releasably engage the vaporising chamber.
5. A container as claimed in any preceding claim in which the first accommodating means comprises an upstream inlet.
6. A container as claimed in Claim 5 in which the upstream inlet is formed by an upstream opening.
7. A container as claimed in Claim 5 or 6 in which the first accommodating means comprises a first permeable means located in the upstream inlet.
8. A container as claimed in any preceding claim in which the second accommodating means comprises a downstream outlet.

9. A container as claimed in Claim 8 in which the downstream outlet is formed by a downstream opening.
10. A container as claimed in Claim 8 or 9 in which the second accommodating means comprises a second permeable means located in the downstream outlet.
11. A container as claimed in any preceding claim in which the container extends between an upstream end and a downstream end, the first accommodating means being located adjacent the upstream end and the second accommodating means being located adjacent the downstream end.
12. A container as claimed in Claim 11 in which the outer transverse cross-sectional area of the container intermediate the upstream and downstream ends thereof is substantially similar to the inner transverse cross-sectional area of the vaporising chamber.
13. A container as claimed in Claim 11 or 12 in which the outer transverse cross-sectional area of the container intermediate the upstream and downstream ends thereof is just less than the inner transverse cross-sectional area of the vaporising chamber.
14. A container as claimed in any of Claims 11 to 13 in which the container comprises a side wall which defines the hollow interior region, the side wall extending between the upstream end and the downstream end.
15. A container as claimed in Claim 14 in which the side wall defines the upstream opening adjacent the upstream end, and the downstream opening adjacent the downstream end.
16. A container as claimed in any of Claims 6 to 15 in which the upstream opening is closed by an upstream end cap.

17. A container as claimed in Claim 16 in which the upstream end cap comprises the first accommodating means.
18. A container as claimed in Claim 16 or 17 in which the upstream end cap is
5 formed by the first permeable means.
19. A container as claimed in any of Claims 6 to 18 in which the downstream opening is closed by a downstream end cap.
- 10 20. A container as claimed in Claim 19 in which the downstream end cap comprises the second accommodating means.
21. A container as claimed in Claim 19 or 20 in which the downstream end cap is formed by the second permeable means.
- 15 22. A container as claimed in any of Claims 14 to 21 in which the side wall is of a heat conducting material.
23. A container as claimed in any of Claims 14 to 22 in which the side wall is of a
20 paper based material.
24. A container as claimed in any of Claims 14 to 23 in which the side wall is of cardboard material.
- 25 25. A container as claimed in any of Claims 14 to 24 in which the side wall is of a foil material.
26. A container as claimed in any of Claims 14 to 25 in which the side wall is of a
metal foil.
- 30 27. A container as claimed in any of Claims 14 to 26 in which a portion of the container is impermeable to the aerosol.

28. A container as claimed in Claim 27 in which the portion of the container which is impermeable to the aerosol is also impermeable to the carrier fluid.

5 29. A container as claimed in Claim 27 or 28 in which the impermeable portion of the container is located intermediate the first accommodating means and the second accommodating means.

10 30. A container as claimed in any of Claims 27 to 29 in which the side wall forms the impermeable portion of the container.

31. A container as claimed in any of Claims 27 to 30 in which the side wall is of a gauze material.

15 32. A container as claimed in Claim 31 in which the side wall is of a gauze of metal material.

33. A container as claimed in any of Claims 27 to 32 in which the side wall of the container is adapted for engaging the vaporising chamber.

20

34. A container as claimed in any of Claims 27 to 33 in which the side wall of the container is adapted for engaging a corresponding side wall of the vaporising chamber.

25 35. A container as claimed in Claim 34 in which the side wall of the container is adapted for engaging the corresponding side wall of the vaporising chamber with a heat transfer fit.

30 36. A container as claimed in Claim 34 or 35 in which the side wall of the container is adapted for slideably engaging the corresponding side wall of the vaporising chamber.

37. A container as claimed in any of Claims 14 to 36 in which the side wall is of cylindrical construction.
38. A container as claimed in any of Claims 11 to 37 in which the second
5 accommodating means comprises an outlet tube extending from the container.
39. A container as claimed in Claim 38 in which the second permeable means is located adjacent the outlet tube.
- 10 40. A container as claimed in Claim 38 or 39 in which the second permeable means is located in the outlet tube.
41. A container as claimed in any of Claims 38 to 40 in which the second permeable means is in the form of a plug.
15
42. A container as claimed in any of Claims 38 to 41 in which the outlet tube terminates in a mouthpiece.
43. A container as claimed in any of Claims 38 to 41 in which a heat sink means
20 is located in the outlet tube.
44. A container as claimed in Claim 43 in which the heat sink means is located in the outlet tube intermediate the second permeable means and the mouthpiece.
- 25 45. A container as claimed in any of Claims 38 to 44 in which the outlet tube is of transverse cross-section which is substantially similar to the transverse cross-section of the container.
46. A container as claimed in any of Claims 38 to 45 in which the outlet tube is of
30 circular transverse cross-section.
47. A container as claimed in Claim 46 in which the outlet tube is of diameter

which is similar to the diameter of the side wall of the container.

48. A container as claimed in any of Claims 38 to 47 in which the container is adapted for engaging the vaporising chamber with the outlet tube extending
5 therefrom to provide access to the mouthpiece.

49. A container as claimed in any of Claims 19 to 45 in which the downstream end cap is of an impermeable material, and defines an outlet opening.

10 50. A container as claimed in Claim 49 in which the outlet tube extends from the downstream end cap and communicates with the hollow interior region of the container through the outlet opening in the downstream end cap.

51. A container as claimed in Claim 49 or 50 in which the second permeable
15 means is located adjacent the outlet opening in the downstream end cap.

52. A container as claimed in any preceding claim in which the container is adapted for accommodating a heat transfer member of the vaporising chamber into the hollow interior region of the container for transferring heat to the vaporisable
20 matter contained therein.

53. A container as claimed in Claim 52 in which the upstream end of the container is adapted for accommodating the heat transfer member into the hollow interior region thereof.
25

54. A container as claimed in Claim 52 or 53 in which the upstream end cap is adapted for accommodating the heat transfer member into the hollow interior region.

55. A container as claimed in any of Claims 52 to 54 in which a heat transfer
30 member accommodating slit is formed in the container for accommodating the heat transfer member therethrough to the hollow interior region thereof.

56. A container as claimed in Claim 55 in which the heat transfer accommodating slit is formed in the upstream end cap.

57. A container as claimed in Claim 55 or 56 in which the heat transfer member
5 accommodating slit is formed in the first permeable means.

58. A container as claimed in any preceding claim in which the first permeable means comprises a first permeable material which is permeable to the carrier fluid.

10 59. A container as claimed in Claim 58 in which the first permeable material is a paper based material.

60. A container as claimed in Claim 58 or 59 in which the first permeable material is a gauze.

15

61. A container as claimed in any of Claims 58 to 60 in which the first permeable material is a gauze of a metal material.

62. A container as claimed in any of Claims 58 to 61 in which the first permeable
20 material is perforated.

63. A container as claimed in any preceding claim in which the second permeable means comprises a second permeable material which is permeable to the aerosol of the carrier fluid and the vapour of the vaporisable constituent.

25

64. A container as claimed in Claim 63 in which the second permeable material is a paper based material.

65. A container as claimed in Claims 63 or 64 in which the second permeable
30 material is a gauze.

66. A container as claimed in any of Claims 63 to 65 in which the second

permeable material is a gauze of a metal material.

67. A container as claimed in any of Claims 63 to 66 in which the second permeable material is perforated.

5

68. A container as claimed in any preceding claim in which the second permeable means comprises a filter medium.

69. A container as claimed in Claim 68 in which the filter medium of the second permeable means is adapted for substantially inhibiting the passage of undesirable vapours from the aerosol passing therethrough.

10

70. A container as claimed in Claim 68 or 69 in which the filter medium of the second permeable means is adapted for substantially inhibiting the passage of tar and other undesirable fluids passing therethrough.

15

71. A container as claimed in any preceding claim in which the vaporisable matter contained in the hollow interior region of the container is in particulate form.

72. A container as claimed in any preceding claim in which the vaporisable matter contained in the hollow interior region is of particle size of maximum dimensions in the range of 50 microns to 5mm.

20

73. A container as claimed in any preceding claim in which the vaporisable matter is in strip form.

25

74. A container as claimed in Claim 73 in which the strips of the vaporisable matter are of maximum transverse dimensions in the range of 50 microns to 5mm.

75. A container as claimed in Claim 73 or 74 in which the strips of the vaporisable matter are of length in the range of 5mm to 40mm.

30

76. A container as claimed in any of Claims 73 to 75 in which the vaporisable matter contained in the hollow interior region comprises a blend of vaporisable matter of different strip sizes, and the strip sizes of the blend of the vaporisable matter are selected for maintaining the level of vapour of the vaporisable constituent
5 in the aerosol substantially constant over the time period during which the vaporisable matter is being heated from the time the vaporisable matter is raised to a temperature suitable for vaporising the constituent until substantially all of the vapour has been evaporated from the vaporisable constituent.

10 77. A container as claimed in any of Claims 73 to 76 in which the vaporisable matter contained in the hollow interior region comprises a blend of vaporisable matter of different particle sizes and different strip sizes, and the particle sizes and the strip sizes of the blend of the vaporisable matter are selected for maintaining the level of vapour of the vaporisable constituent in the aerosol substantially constant
15 over the time period during which the vaporisable matter is being heated from the time the vaporisable matter is raised to a temperature suitable for vaporising the constituent until substantially all of the vapour has been evaporated from the vaporisable constituent.

20 78. A container as claimed in any of Claims 71 to 77 in which the vaporisable matter contained in the hollow interior region comprises a blend of vaporisable matter of different particle sizes, and the particle sizes of the blend of the vaporisable matter are selected for maintaining the level of vapour of the vaporisable constituent in the aerosol substantially constant over the time period during which the
25 vaporisable matter is being heated from the time the vaporisable matter is raised to a temperature suitable for vaporising the constituent until substantially all of the vapour has been evaporated from the vaporisable constituent.

79. A container as claimed in any preceding claim in which the vaporisable
30 matter contained in the hollow interior region of the container is selected from one or more of the following:

plant matter

herbs

tobacco

mullein	passion flower	cloves
yohimbe	mint	tea
eucalyptus	camomile.	

5 80. A container as claimed in any preceding claim in which the vaporisable matter contained in the hollow interior region of the container is tobacco.

81. A container as claimed in any preceding claim in which the container is in the form of a sachet adapted for engagement in a plug portion of the vaporising chamber
10 with the plug portion of the vaporising chamber in engagement with the vaporising chamber.

82. A method for vaporising a vaporisable constituent of vaporisable matter to form an aerosol, the method comprising placing the vaporisable matter in a hollow
15 interior region of a container comprising a first accommodating means for accommodating a carrier fluid into the hollow interior region and a second accommodating means for accommodating the aerosol from the hollow interior region, placing the container in a vaporising chamber of a vaporising device, heating the container and the vaporisable matter therein to a temperature at which the
20 vaporisable constituent vaporises, and drawing a carrier fluid into the hollow interior region of the container through the first accommodating means and through the hollow interior region for entraining vapour of the vaporised constituent in the carrier fluid to form the aerosol and drawing the aerosol through the second accommodating means.

25 83. A method as claimed in Claim 82 in which the vaporisable matter is in particulate form.

84. A method as claimed in Claim 83 in which the vaporisable matter is of particle
30 size of maximum dimensions in the range of 50 microns to 5mm.

85. A method as claimed in any of Claims 82 to 84 in which the vaporisable

matter is in strip form.

86. A method as claimed in Claim 85 in which the vaporisable matter of strip form is of maximum transverse dimensions in the range of 50 microns to 5mm.

5

87. A method as claimed in Claim 85 or 86 in which the strips of the vaporisable matter are of length in the range of 5mm to 40mm.

88. A method as claimed in any of Claims 85 to 87 in which the vaporisable
10 matter is in the form of a blend of strips of the vaporisable matter of different sizes, the sizes of the strips of the blend being selected for maintaining the level of the vapour of the vaporisable constituent in the aerosol substantially constant over the time period during which the vaporisable matter contained in the container is being heated from the time the vaporisable matter is raised to a temperature suitable for
15 vaporising the vaporisable constituent until substantially all of the vapour has been evaporated from the vaporisable constituent.

89. A method as claimed in any of Claims 85 to 88 in which the vaporisable
20 matter is in the form of a blend of strips and particles of respective different sizes, the sizes of the strips and the sizes of the particles of the blend being selected for maintaining the level of the vapour of the vaporisable constituent in the aerosol substantially constant over the time period during which the vaporisable matter contained in the container is being heated from the time the vaporisable matter is raised to a temperature suitable for vaporising the vaporisable constituent until
25 substantially all of the vapour has been evaporated from the vaporisable constituent.

90. A method as claimed in any of Claims 83 to 89 in which the vaporisable
30 matter is in the form of a blend of particles of different sizes, and the sizes of the particles of the blend are selected for maintaining the level of the vapour of the vaporisable constituent in the aerosol substantially constant over the time period during which the vaporisable matter contained in the container is being heated from the time the vaporisable matter is raised to a temperature suitable for vaporising the

vaporisable constituent until substantially all of the vapour has been evaporated from the vaporisable constituent.

91. A method as claimed in any of Claims 82 to 90 in which the temperature to
5 which the vaporisable matter within the container is heated is varied for maintaining the level of the vaporisable constituent substantially constant in the aerosol over a time period from the time the vaporisable matter is raised to a temperature sufficient for vaporising the vaporisable constituent until substantially all the vapour has been evaporated from the vaporisable constituent.

10

92. A vaporising device comprising a vaporising chamber and a heat source for heating the vaporising chamber, and a container as claimed in any of Claims 1 to 81 located in the vaporising chamber, the vaporising chamber having a carrier fluid inlet for facilitating drawing of a carrier fluid into the hollow interior region of the container
15 through the first permeable means for entraining vapour of a vaporisable constituent of the vaporisable matter in the carrier fluid to form an aerosol of the carrier fluid and the vapour of the vaporisable constituent, so that the aerosol can be drawn from the hollow interior region of the container through the second permeable means.

20

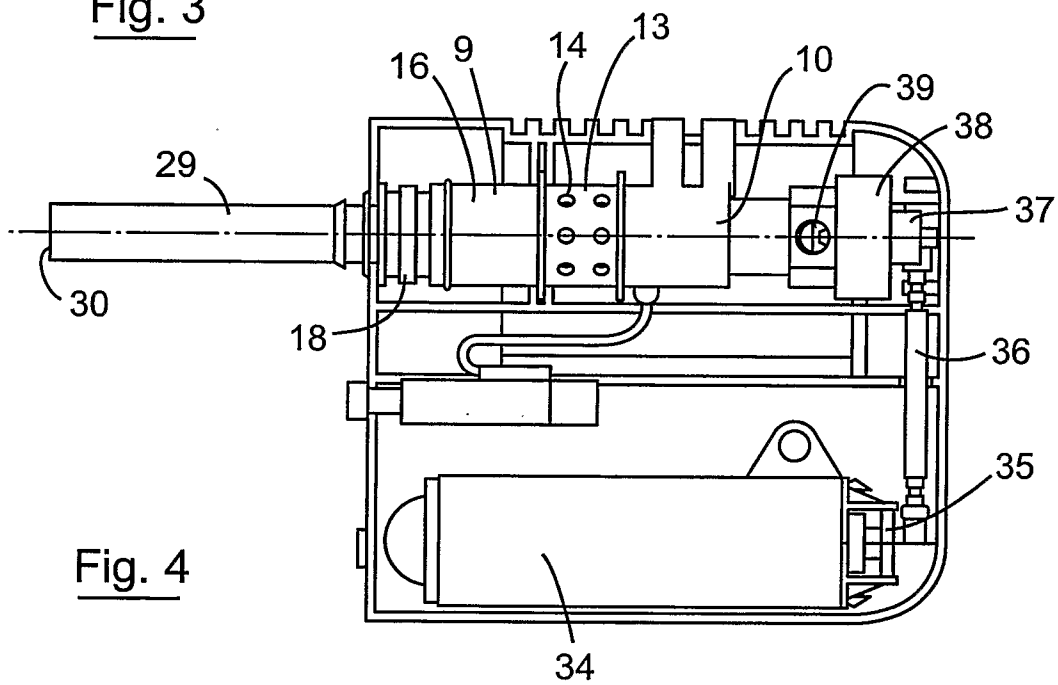
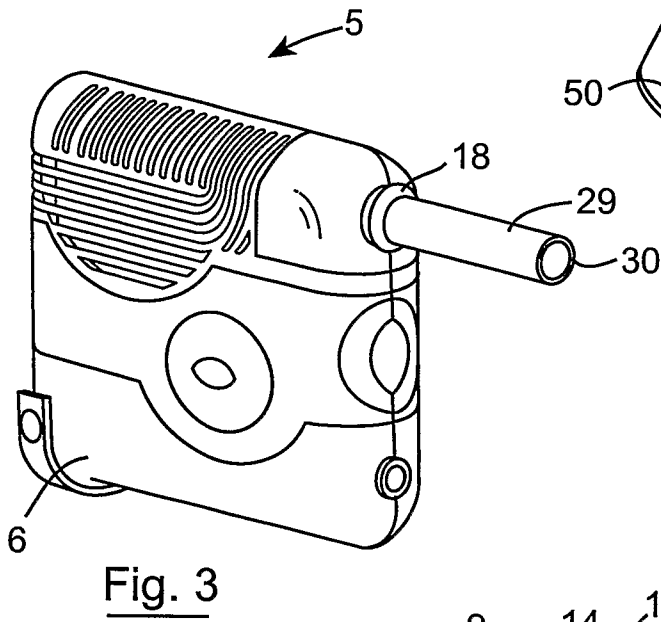
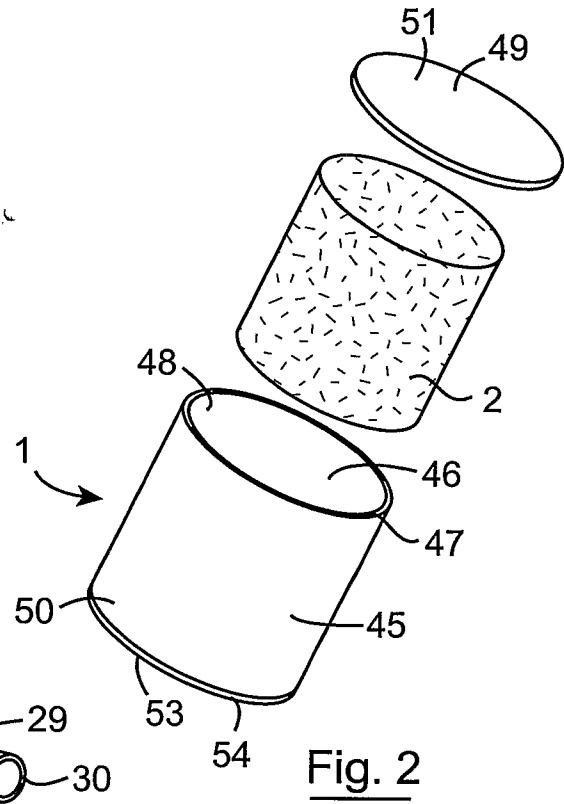
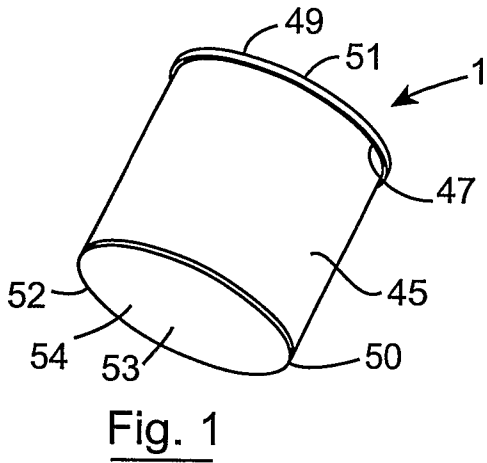

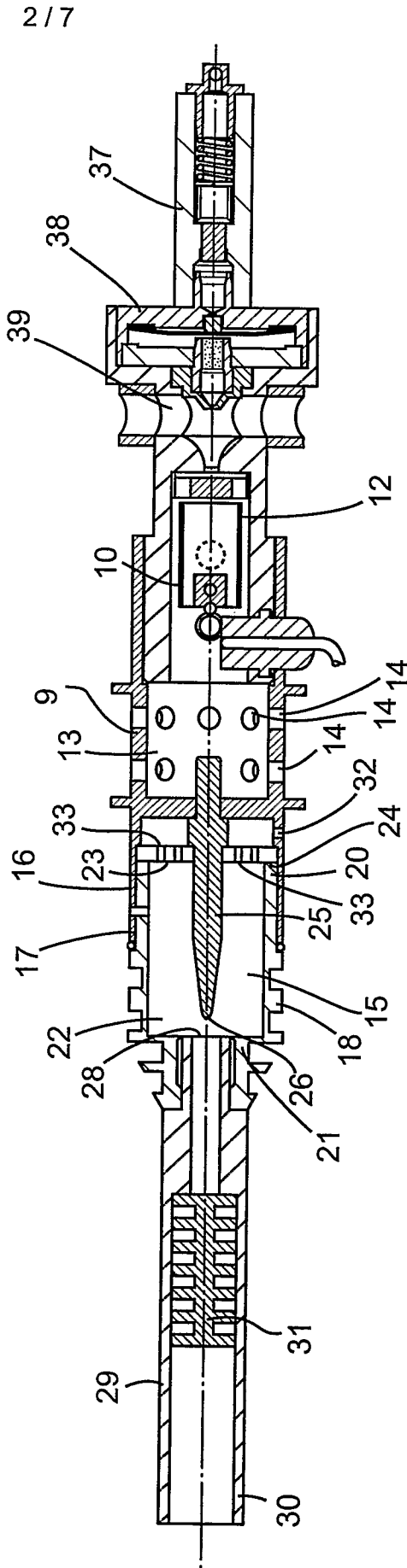
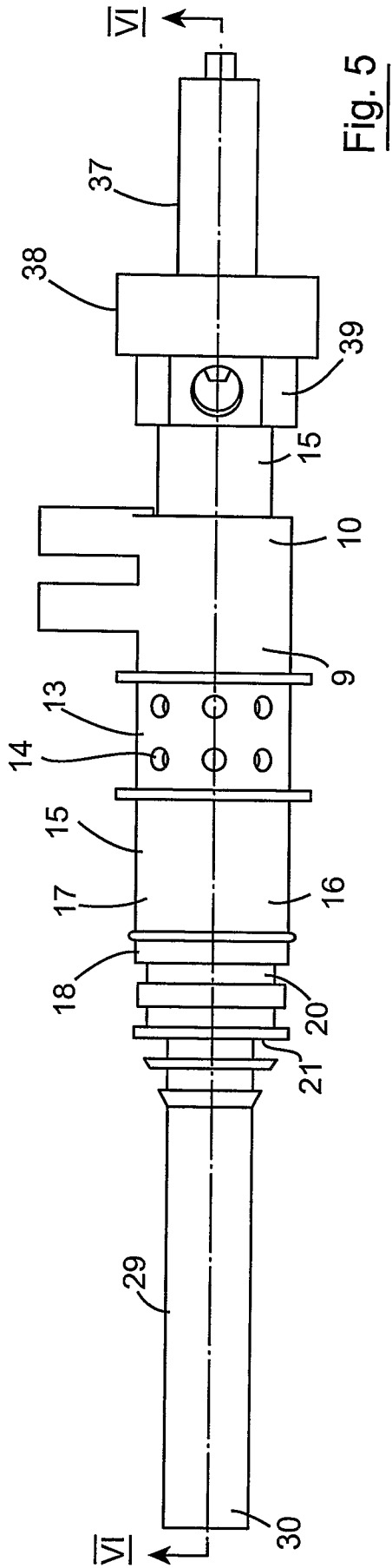

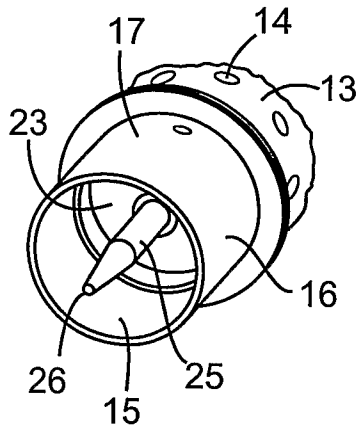

Fig. 7

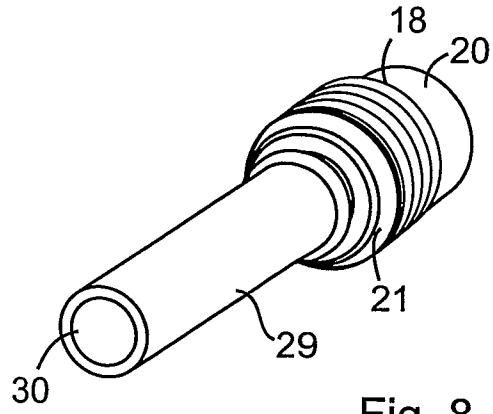

Fig. 8

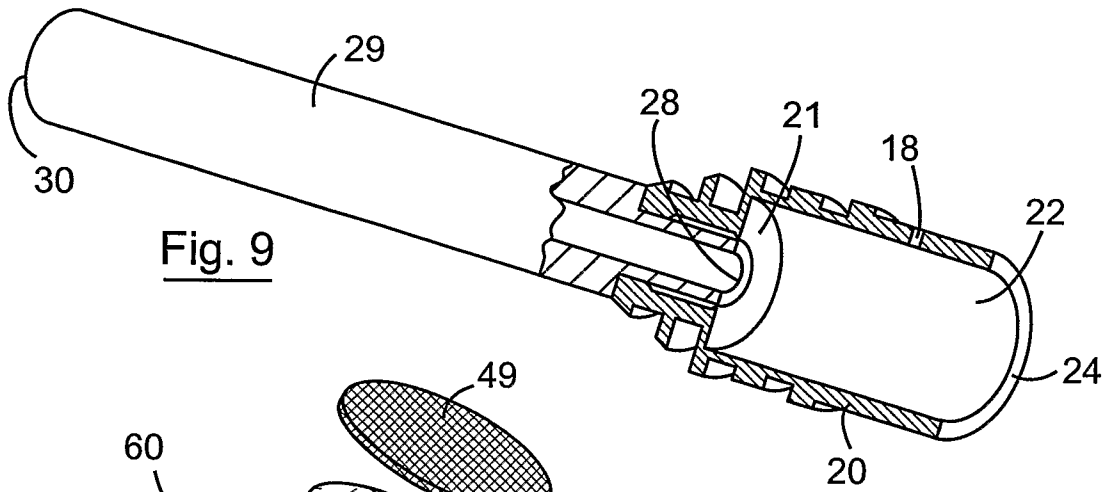

Fig. 9

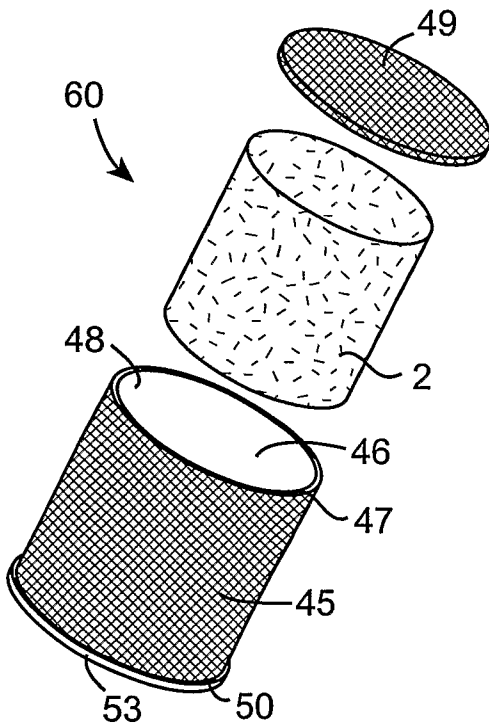

Fig. 12

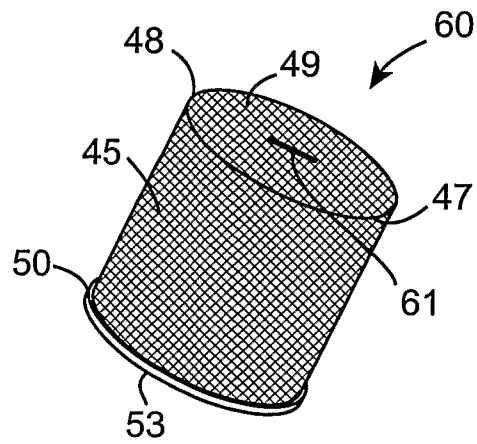

Fig. 11

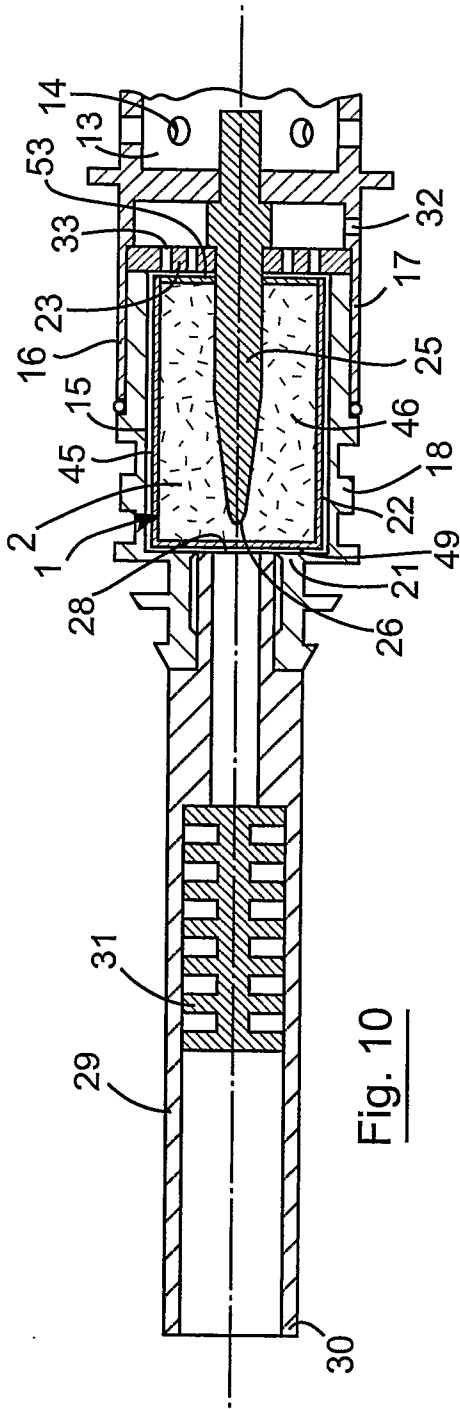

Fig. 10

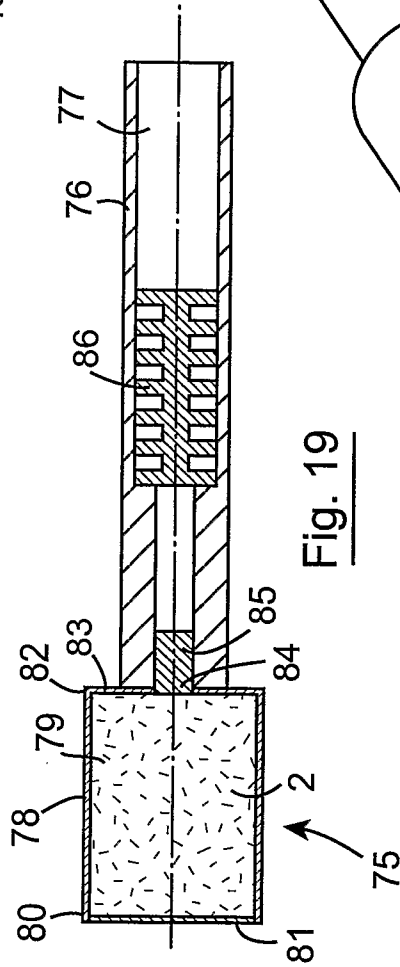

Fig. 19

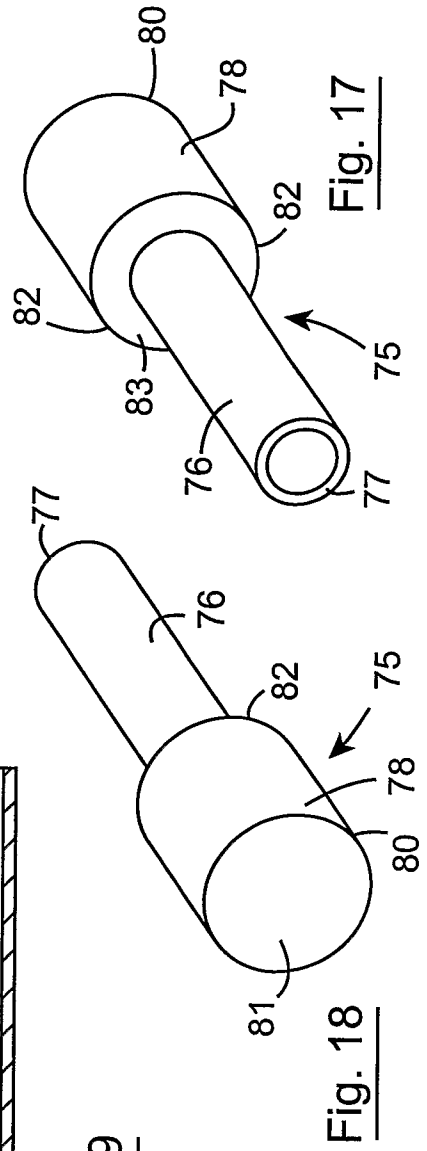

Fig. 17

Fig. 18

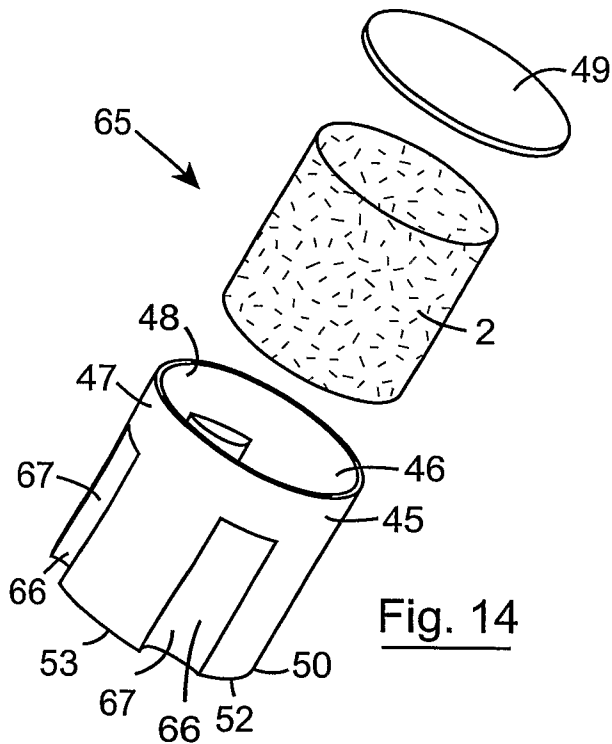

Fig. 14

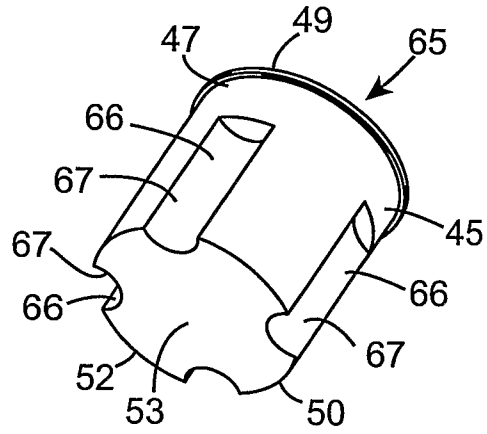

Fig. 13

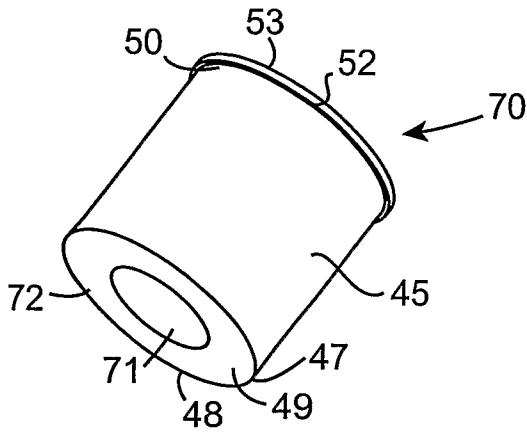

Fig. 15

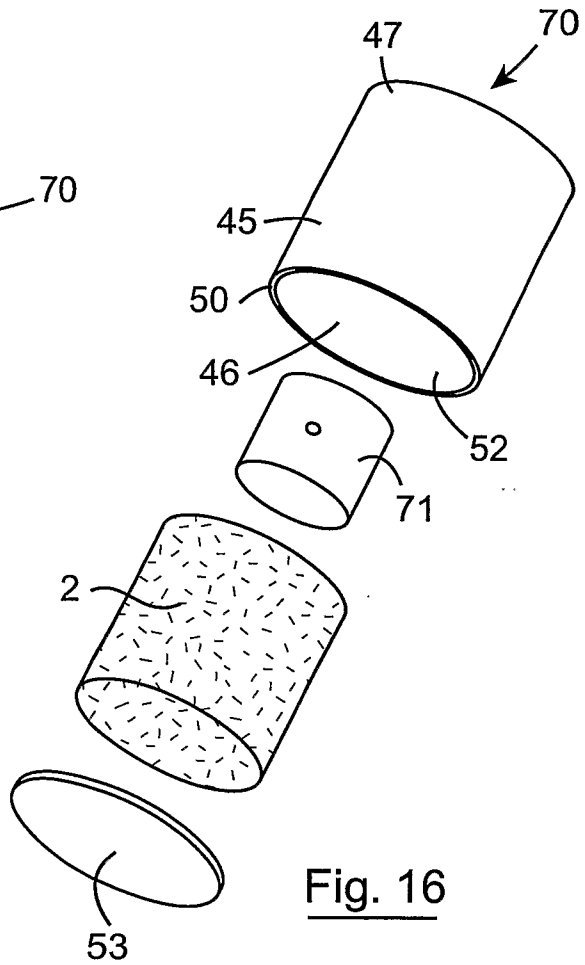

Fig. 16

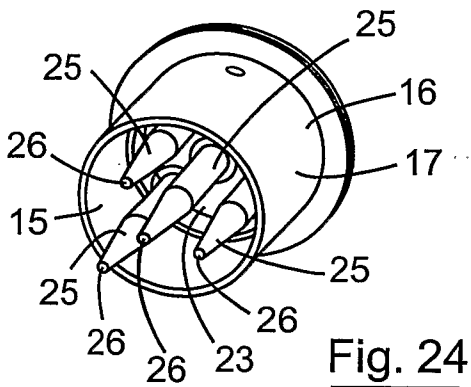
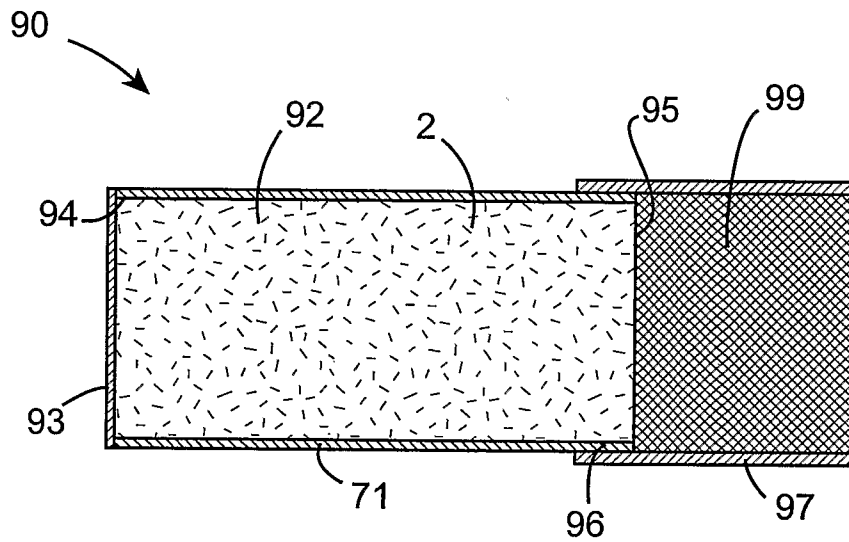
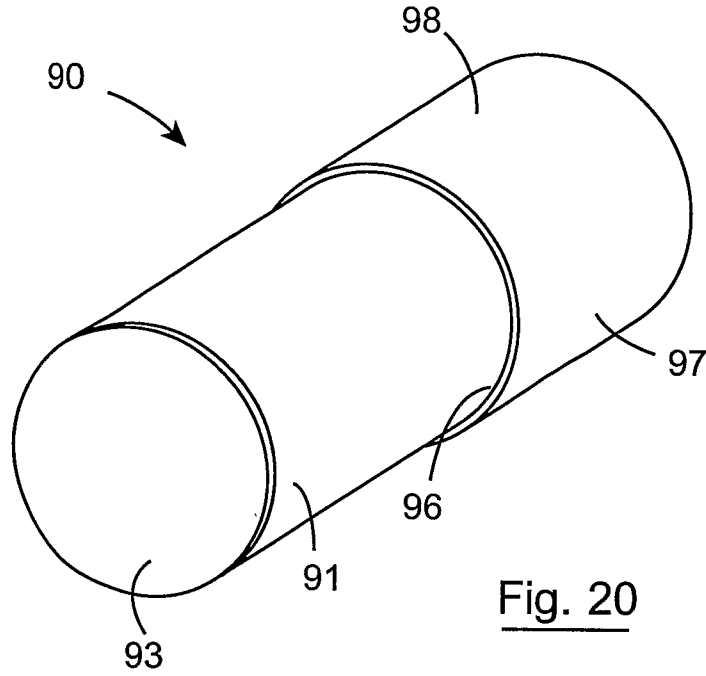

Fig. 24



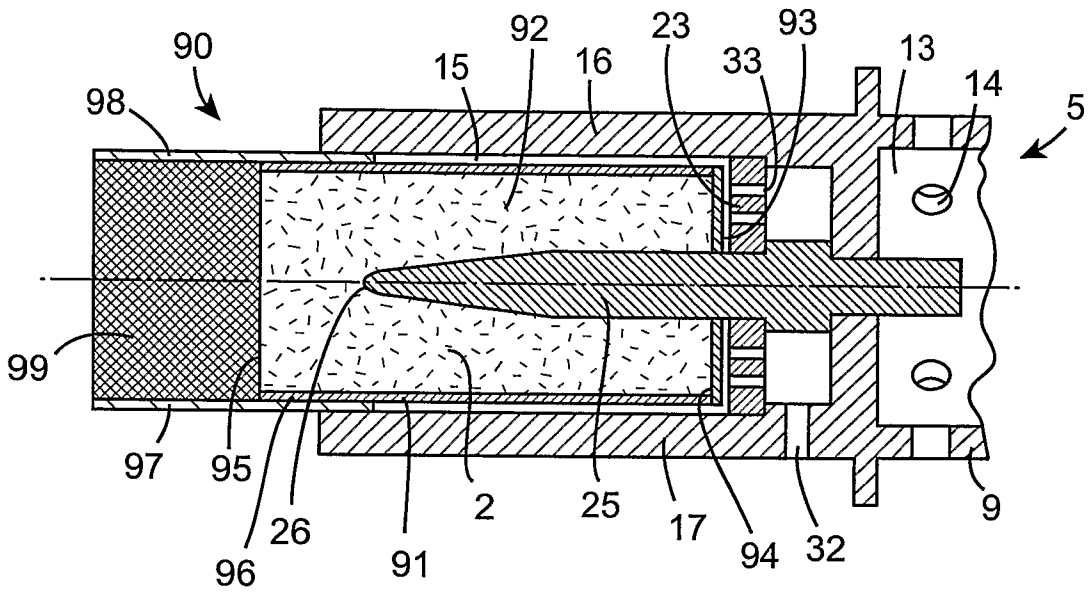

Fig. 22

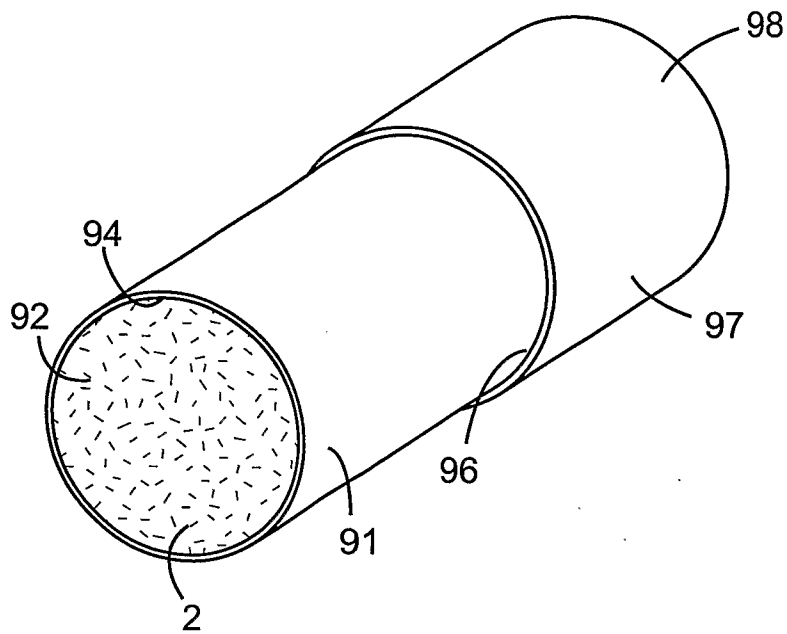

Fig. 23