



INTERNATIONAL APPLICATION PUBLISHED UNDER THE PATENT COOPERATION TREATY (PCT)

<p>(51) International Patent Classification ⁷ : G01J 3/18, 3/28, 3/02</p>	<p>A1</p>	<p>(11) International Publication Number: WO 00/40935</p> <p>(43) International Publication Date: 13 July 2000 (13.07.00)</p>
<p>(21) International Application Number: PCT/DK00/00006</p> <p>(22) International Filing Date: 7 January 2000 (07.01.00)</p> <p>(30) Priority Data: PA 1999 00020 8 January 1999 (08.01.99) DK</p> <p>(71) Applicant (for all designated States except US): IBSEN MICRO STRUCTURES A/S [DK/DK]; Gammelgårdsvej 65, DK-3520 Farum (DK).</p> <p>(72) Inventors; and (75) Inventors/Applicants (for US only): IBSEN, Per, Eld [DK/DK]; Peblinge Dosseringen 4. st. tv., DK-2200 København N (DK). ROSE, Bjarke [DK/DK]; Færøvej 13, 1., DK-2800 Lyngby (DK). RASMUSSEN, Michael [DK/DK]; Svend Gønges Vej 34, DK-2700 Brønshøj (DK).</p> <p>(74) Agent: HOFMAN-BANG A/S; Hans Bekkevolds Allé 7, DK-2900 Hellerup (DK).</p>		<p>(81) Designated States: AE, AL, AM, AT, AT (Utility model), AU, AZ, BA, BB, BG, BR, BY, CA, CH, CN, CR, CU, CZ, CZ (Utility model), DE, DE (Utility model), DK, DK (Utility model), DM, EE, EE (Utility model), ES, FI, FI (Utility model), GB, GD, GE, GH, GM, HR, HU, ID, IL, IN, IS, JP, KE, KG, KP, KR, KZ, LC, LK, LR, LS, LT, LU, LV, MA, MD, MG, MK, MN, MW, MX, NO, NZ, PL, PT, RO, RU, SD, SE, SG, SI, SK, SK (Utility model), SL, TJ, TM, TR, TT, TZ, UA, UG, US, UZ, VN, YU, ZA, ZW, ARIPO patent (GH, GM, KE, LS, MW, SD, SL, SZ, TZ, UG, ZW), Eurasian patent (AM, AZ, BY, KG, KZ, MD, RU, TJ, TM), European patent (AT, BE, CH, CY, DE, DK, ES, FI, FR, GB, GR, IE, IT, LU, MC, NL, PT, SE), OAPI patent (BF, BJ, CF, CG, CI, CM, GA, GN, GW, ML, MR, NE, SN, TD, TG).</p> <p>Published With international search report.</p>

(54) Title: SPECTROMETER

(57) Abstract

A method and apparatus for measuring spectral information of light from at least one object (15); said apparatus comprising at least one light detecting means (34); and at least one transparent body (31) having a front side (F) including: an entrance surface (311) having positioned in or near thereof an entrance aperture means (30), and at least one reflecting surface (312); and said transparent body further having a back side (B) including: at least one reflecting surface (313) for reflecting light received from said entrance aperture means, and an exit surface (314); said detecting means being positioned in or near said exit surface; said first reflecting surface, said second reflecting surface, or both, having at least one diffractive optical element (32) and/or at least one focusing means (33). Such apparatus comprising more spectral channels, and such apparatus comprising distance sensing means.

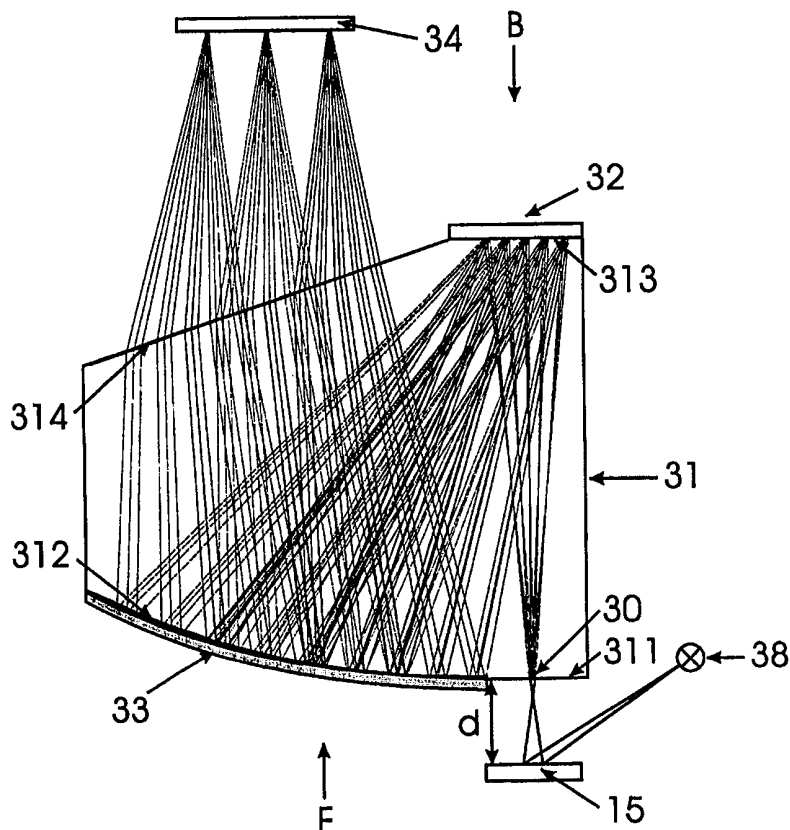

FOR THE PURPOSES OF INFORMATION ONLY

Codes used to identify States party to the PCT on the front pages of pamphlets publishing international applications under the PCT.

AL	Albania	ES	Spain	LS	Lesotho	SI	Slovenia
AM	Armenia	FI	Finland	LT	Lithuania	SK	Slovakia
AT	Austria	FR	France	LU	Luxembourg	SN	Senegal
AU	Australia	GA	Gabon	LV	Latvia	SZ	Swaziland
AZ	Azerbaijan	GB	United Kingdom	MC	Monaco	TD	Chad
BA	Bosnia and Herzegovina	GE	Georgia	MD	Republic of Moldova	TG	Togo
BB	Barbados	GH	Ghana	MG	Madagascar	TJ	Tajikistan
BE	Belgium	GN	Guinea	MK	The former Yugoslav Republic of Macedonia	TM	Turkmenistan
BF	Burkina Faso	GR	Greece			TR	Turkey
BG	Bulgaria	HU	Hungary	ML	Mali	TT	Trinidad and Tobago
BJ	Benin	IE	Ireland	MN	Mongolia	UA	Ukraine
BR	Brazil	IL	Israel	MR	Mauritania	UG	Uganda
BY	Belarus	IS	Iceland	MW	Malawi	US	United States of America
CA	Canada	IT	Italy	MX	Mexico	UZ	Uzbekistan
CF	Central African Republic	JP	Japan	NE	Niger	VN	Viet Nam
CG	Congo	KE	Kenya	NL	Netherlands	YU	Yugoslavia
CH	Switzerland	KG	Kyrgyzstan	NO	Norway	ZW	Zimbabwe
CI	Côte d'Ivoire	KP	Democratic People's Republic of Korea	NZ	New Zealand		
CM	Cameroon			PL	Poland		
CN	China	KR	Republic of Korea	PT	Portugal		
CU	Cuba	KZ	Kazakstan	RO	Romania		
CZ	Czech Republic	LC	Saint Lucia	RU	Russian Federation		
DE	Germany	LI	Liechtenstein	SD	Sudan		
DK	Denmark	LK	Sri Lanka	SE	Sweden		
EE	Estonia	LR	Liberia	SG	Singapore		

SPECTROMETER

5 DESCRIPTION1. BACKGROUND OF THE INVENTION

10 The present invention relates to an apparatus and methods for measuring spectral information of light from at least one object.

The Technical Field

15 Spectroscopy is commonly practised with the use of cumbersome equipment comprising mirrors, lenses, and positioning equipment. However, recently monolithic spectrometers which are feasible for miniaturization, and less susceptible to misalignment, distortion, moisture,
20 malfunction and other defects, have opened up for wider applications.

Known monolithic spectrometers are generally unilateral-type spectrometers which are constructed so that the
25 light entrance is positioned on the same side of the light propagating body as the light exits the body. This, however, limits the use of the spectrometers to applications wherein the detection means can be allowed to occupy space between the spectrometer and the object
30 to be measured.

An example of unilateral-type spectrometers is based on the Czerny-Turner configuration, which limits the minimum size of the compact spectrometer because of the required
35 means for collimating the incoming light onto the diffraction means. Also, the Czerny-Turner configuration

requires that entrance and detection means are placed on the same side of the spectrometer body.

5 Most monolithic spectrometers are not constructed to meet mass producing requirements. Often, the required production process involves steps such as diamond turning, grinding, and polishing. These processes are generally carried out in sequential steps, and known to be very expensive.

10

Generally, known monolithic spectrometers are rather simple. They consist of only one spectrometer channel, i.e. they can only measure one object at a time. Additionally, known monolithic spectrometers suffer from not being interference free, i.e. the measuring light contains spectral information from both the object and the reference light. This is a disadvantage in many practical situations where knowledge of the reference light is required to obtain precise spectral characteristics of the measured object. Either, the spectral characteristics of the reference light has to be known, or it has to be measured in the same spectrometer either prior to or immediately after measurements have been performed on the object measured. This method is both time consuming and can cause erroneous measurements if the reference light source varies over time.

25
30
35 Additionally, none of the prior art monolithic spectrometers include distance sensing means and consequently they are sensitive to variations in object distance. For a unilateral-type spectrometer (e.g. the Czerny-Turner configuration) it is not straightforward to integrate the distance sensing means within the monolithic spectrometer, because entrance means and detection means are placed on the same side of the spectrometer.

Prior Art Disclosures

5 US Patent No. 5,026,160, Dorain et al., "Monolithic
Optical Programmable Spectrograph (MOPS)," discloses a
unilateral solid monolithic spectrograph having a Czerny-
Turner configuration wherein the incoming light is
collimated into a parallel beam of light which is
10 directed onto a diffraction grating and wherein the
diffracted beam of light is focused onto a light exit
placed on the same side of the monolithic body as the
light entrance. The spectrometer has a base of BK7
optical glass to which all components, such as mirrors
15 and gratings, are affixed with optical index matching
glue. Affixing the components, however, require critical
alignment procedures.

International Application No. WO 97/02475, Rajic et al.,
20 "Monolithic Spectrometer and Method for Fabrication of
Same", discloses another compact spectrometer utilizing
the Czerny-Turner configuration. The spectrometer is a
single body of translucent material with positioned
surfaces for transmission, reflection, and spectral
25 analysis of light rays. In this configuration, the
mirrors and the grating are fabricated in the single body
of material, and consequently the critical alignment
steps can be avoided.

30 US Patent No. 5,159,404, Bittner, "Diode Array
Spectrometer", and Company Product Information No 79-802-
e, Carl Zeiss Jena, "MMS Spectral Sensors", disclose a
compact spectrometer where the grating and the focusing
mirror is combined in a single element. This makes it
35 possible to construct a very compact spectrometer.

However, stray light generated by imperfect gratings cannot simply be suppressed.

5 All these prior art monolithic spectrometers described above are unilateral-type spectrometers. This means that the entrance and detection means are both placed on the same side of the spectrometer, which limits the application areas because the spectrometer might not always be placed as close to the object as is desired.

10

International Application No. WO 96/05487, Ridyard and Shrewsbury, "Radiation detector", disclose a monolithic transmission spectrometer for UV detection in which a curved reflective face and a planar diffraction grating focus light from the entrance aperture means onto the radiation detector means. This configuration relies on a fixed order of the optical elements of focusing and then diffracting the light which makes it difficult if not impossible to easily compensate or avoid aberrations, in particular chromatic aberration. In addition because the diffracted light is under a large solid angle of the detector, stray light originated from imperfections in the grating cannot easily be suppressed.

15

25 All these prior art spectrometers are constructed from a solid block of transparent material (e.g., glass). The production process used is not applicable to mass production, because it is based on diamond turning, grinding and polishing. Furthermore, it has neither been indicated nor suggested to design spectrometers having planar-like structures which are more suited for mass production.

30

35 European Application No. EP 0 942 266 A1, H. Teichmann, "Spektrometer" discloses a compact spectrometer which is

manufactured by use of replication techniques. This spectrometer is a unilateral spectrometer based on the Czerny-Turner configuration which has the the disadvantages mentioned above.

5

All the above mentioned prior art spectrometers only include one spectrometer channel, which only allow measurement of one object at a time. Additionally, the prior art techniques are all sensitive to variations in the reference light used to illuminate the object.

10

Further, inclusion of distance sensing means is not straightforward in these spectrometers just as the cited prior art techniques are sensitive to variations in object distance.

15

US Application No. 5,493,393, Beranek *et al.*, "Planar Waveguide Spectrograph", discloses a compact unilateral spectrograph for wavelength division multiplexing applications. The spectrograph is based on glass-optical planar waveguides, and a multi-channel spectrograph is disclosed. The multi-channel spectrograph is manufactured by simply stacking identical waveguide spectrographs on top of each other. This prior art spectrograph is not designed in a planar-like manner, which is feasible for mass production, neither are the additional channels utilized for measuring reference light.

20

25

US Application No. 4,770,530, Van Aken *et al.*, "Remote Spectrophotometer", discloses a non-compact spectrophotometer including means for directing reference light to a reference detector. In one preferred embodiment, a single detector is used to measure the integrated reference light. This embodiment does not provide a very precise reference measurement. In yet another preferred embodiment, the object and reference light are measured

30

35

sequentially, which does not provide a precise reference measurement either, because the reference light might have changed. In yet another preferred embodiment, the object and reference light are directed to separate spectrometers, which is not a very cost effective solution. This illustrates why non-compact spectrometers do not provide multi-functionality nearly to the extent compact spectrometers do.

10

International Application No. WO 98/12541, Hammer et al., "Improved Spectrophotometer", discloses a non-compact spectrophotometer including a reference detector for conducting a reference measurement simultaneously with measurements performed on the object. However, the measurements are performed on the object to be measured after the light has been dispersed by a diffractive grating, i.e. the object is not illuminated by polychromatic light.

20

International Application No. WO 98/01729, Ellsmore et al., "Spectrometer", discloses a non-monolithic spectrometer with two channels. However, in addition to being non-monolithic, the two channels are not exactly identical because they create different focus for different wavelengths. Further, the measurements are performed on the object to be measured (here a gas, e.g. carbon monoxide) after the light has been dispersed by a diffractive grating, i.e. the object is not illuminated by polychromatic light.

30

US Patent No. 4,707,138, Coatney, "Color Measuring and Control Device", discloses a color-detecting device. This prior art does not utilize a spectrometer, but monitor only two known wavelengths to obtain the color (spectral characteristics) of the object. In addition, the color

35

sensor comprises a height detector to provide a signal indicating the distance between the object and color sensor. The height measurements are used to modify the color readings accordingly. The sensor is not compact, neither is the distance sensing means an integrated part of the color sensor, but a separate unit.

2. DISCLOSURE OF THE INVENTION

10

Object of the Invention

In an aspect, it is the object of the present invention to provide an improved apparatus and method for measuring spectral information of at least one object. In particular, it is the object to provide an apparatus which is compact and which flexibly can be positioned with respect to the at least one object to be measured.

Also, it is the object of the present invention to provide such an apparatus and method which allow for compensation or reduction of aberration, in particular chromatic aberration.

Further, it is the object of the present invention to provide such an apparatus and method which allow for mass production thereof.

In another aspect, it is the object of the present invention to provide such a method and apparatus for which the measurement of spectral distribution of the at least one object is not influenced by variations in reference light.

In still a further aspect, it is the object of the present invention to provide such a method and apparatus

for which the measured spectral distribution of at least one object is not influenced by variations in the distance from the light entrance of the apparatus to the object.

5

Further objects will appear from the description of the invention and its preferred embodiments.

10 Solution According to the Invention

"Transmission Spectrometer"

15 According to an aspect of the invention, there is provided an apparatus for measuring spectral information of light from at least one object; said apparatus comprising

20 at least one light detecting means; and

at least one transparent body having a front side and a back side; said front side including:

25 an entrance surface having positioned in or near thereof at least one entrance aperture means for receiving light from the at least one object, and

at least one reflecting surface; and

30

said back side including:

at least one other reflecting surface for reflecting light received from said at least one entrance aperture means to said at least one reflecting surface of the front side, and

35

an exit surface; said exit surface being arranged in a mutual relationship with said at least one light detecting means; said detecting means being positioned in or near thereof, or positioned at a distance there from, for detecting the reflected light from said at least one reflecting surface of the front side;

10 said at least one other reflecting surface of the back side, said at least one reflecting surface of the front side, or both, having at least one diffractive optical element (32) and/or at least one focusing means (33);

15 said at least one diffractive element and said at least one focusing means being arranged so that the transmitted light is diffracted before being focused; and

20 said at least one transparent body being transparent to the lights from the object, said reflecting surface of the back side, and said other reflecting surface of the front side;

which apparatus is compact.

25

Also, the arrangement of the at least one diffractive element and the at least one focusing means so that the transmitted light is diffracted before being focused ensures that compensation or reduction of aberration, in particular chromatic aberration can easily be obtained.

30

Compensation or reduction of aberration can be obtained in any suitable manner involving aberration correcting means under or after the focusing process.

35

In a preferred embodiment, the apparatus further comprises aberration correcting means.

5 In a particularly preferred embodiment, the aberration correcting means comprises that the at least one focusing means is aspheric whereby the wavelength dependent reflection by the aspheric focusing means is used to correct the diffracted light of various wavelengths to the desired focus.

10

In another particularly preferred embodiment, the aberration correcting means comprises tilting a planar exit surface or providing an aspheric exit surface whereby the diffracted light focused by the focusing
15 means is refracted to the desired focus.

In still another particularly preferred embodiment, the aberration correcting means comprises a combination of the at least one focusing means being aspheric and the
20 exit surface being tilted whereby the aberration compensation or reduction can be made more effective.

Further, according to the invention light detecting means are separated from the entrance aperture means, whereby
25 the apparatus can be positioned in a flexible manner with respect to the object(s) to be measured. That is, the apparatus can be positioned very close to one or more objects. This is e.g. particularly useful for applications of compact spectrometers to color
30 measurements in printing machines.

More reflecting surfaces

In many applications it is desired to have a large
35 resolution of the spectrometer. This can be achieved by

providing a long light path in the spectrometer between the entrance aperture means and detecting means.

In a preferred embodiment, the front side includes at least one further reflecting surface; and the said back side includes at least one further reflecting surface; said further reflecting surfaces being arranged to reflect light more times before being received by the at least one focusing means, the at least one diffractive means, or both whereby the light path can be increased and consequently the resolution can be increased.

Entrance Aperture Means

The light from the object to be measured enters the spectrometer through an entrance aperture means. The aperture means serves to achieve a suitable resolution of the spectrometer.

Preferably the entrance aperture means comprises of a rectangular slit, but the light might also be provided through optical waveguide means, in particular optical fiber means, or through other appropriate aperture means, thereby ensuring a desired resolution of the spectrometer and a suitable reception of light.

In another preferred embodiment, the entrance aperture means further comprises a wavelength bandpass filter whereby it is achieved that the spectrometer only analyzes a desired wavelength bandwidth of light, which is particularly useful in order to optimize the signal-to-noise ratio.

35

Diffraction Optical Element

The at least one diffractive optical element is preferably planar or aspheric whereby it can easily be adapted to said at least one reflecting surfaces of the front and back sides depending on their particular function.

In another preferred embodiment, the diffractive optical element is a blazed grating whereby an improved efficiency of the spectrometer is achieved, said efficiency being defined as the amount of light distributed across the light detecting means compared to the amount of light entering the entrance aperture means.

Focusing Surface

The at least one focusing means is preferably an aspheric surface, whereby it is achieved that the optics design of a compact spectrometer can be realized with fewer aberrations. In this regard, the term "aspheric surface" is known in the art, see e.g. ZEMAX, Optical Design Program, User's Guide Version 7.0, Focus Software, Inc., Tucson, AZ (1998) p. 13-4. We note that a spherical surface, which is commonly used in many standard lenses, is a specie of an aspheric surface.

The term "aberrations" is intended to designate the various forms of aberration, e.g. spherical and chromatic aberration, known in the art, e.g., see E. Hecht, "Optics," Addison-Welsey, 1987, Section 6.3.

35

Light Detecting Means

The light detecting means can be positioned either in or near the exit surface of the transparent body of the apparatus, e.g. compact spectrometer, or it can be positioned at a distance from the exit surface. By positioning the light detecting means in or near the exit surface, a very rugged spectrometer is achieved, which is advantageous in many applications where the spectrometer might be subject to vibrations during its use. Also it is advantageous with respect to long term stability of the spectrometer.

The light detection means may be positioned below or above the surface of the exit surface face of the back side of the transparent body. In a preferred embodiment the detection means is positioned below the surface of the exit surface thereby ensuring a more robust spectrometer with less sensitivity of having the components in or near the surface of exit face destroyed by external strikes or the like to the body.

In a preferred embodiment the light detecting means comprises an array detector, whereby it is achieved that each element of the array detector corresponds to either a single wavelength or a narrow bandwidth of wavelengths. Hereby, simultaneous measurement of a desired bandwidth range of wavelength can be measured simultaneously.

In another preferred embodiment the light detection means further comprises a wavelength bandpass filter, whereby it is achieved that the light detection means only analyzes the desired wavelength bandwidth of light which is particularly useful in order to optimize the signal-to-noise ratio.

The Transparent Body

5 In a preferred embodiment, the transparent body is a unitary body or a composed body. Preferably the unitary or composed body is replicated in optical plastic material, e.g. by embossing or molding, whereby it is possible to mass-produce e.g. a very cheap compact spectrometer.

10

In a preferred embodiment the unitary or composed body is replicated such that the reflective surfaces are positioned below the respective surfaces of the front side and back side thereof. This embodiment is particularly advantageous, because the final spectrometer exhibits a box shape with parallel outer surfaces.

15 It is particularly preferred that the transparent body is a composed body comprising a front part, a back part, and optionally an intermediate part; said front part incorporating said entrance aperture means, said at least one diffractive optical element and/or said at least one focusing means; and said back part incorporating said exit surface, said at least one diffractive optical element and/or said at least one focusing means.

20 The intermediate part may be present or not depending on the application. In a preferred embodiment, said optionally intermediate part consists of a material selected from the group consisting of a low cost transparent material, a thermally stable transparent material, and a filtering material, or a combination thereof.

30 The parts of the composed body might be coupled by e.g. optical cement.

The unitary or composed body might also be assembled by single pieces of optical elements, e.g. replicated
5 optical elements or glass optical elements, which are coupled with e.g. optical cement.

Light Absorbing Material

10

The transparent body is preferably covered with light absorbing material, e.g., black paint, apart from apertures necessary for light passage, e.g. the entrance aperture means and at the exit surface. The light
15 absorbing material serves to suppress stray light, i.e. to suppress multiple scattered light inside the transparent body that adds noise to the measurements. The light absorbing material further serves to prevent ambient light to enter the spectrometer and thus add
20 noise to the measurements. Additionally it serves to prevent light from the entrance aperture means to be guided directly to the light detection means, which is possible in a transmission spectrometer, and crucial for the measurements because this effect cannot easily be
25 eliminated electronically.

Imperfections in the diffractive optical element is causing a substantial amount of stray light in all spectrometers. By arranging the optical elements so that
30 light from the diffractive optical element can not be scattered directly onto the light detecting means, inclusion of light absorbing material can eliminate or reduce this highly undesired noise source.

35 Preferably, the light absorbing material has an index of refraction identical to or very close to the index of

refraction of the spectrometer unit, whereby reflections from the interface between said light absorbing material and said spectrometer body is minimized. Hereby it is achieved that the amount of stray light is further
5 suppressed.

In a preferred embodiment where the transparent body is molded, the light absorbing material is also molded into
10 said body.

In yet another preferred embodiment, the light absorbing material is coated, e.g. painted, onto said transparent
body.

15 In another preferred embodiment where the transparent body is a composed body, light absorbing material is positioned inside the composed body, e.g. between the composed units, whereby it is possible to further suppress the amount of stray light and eliminate light
20 scattering directly from the entrance aperture means to the light detection means, because extra sets of apertures can be included.

25 "Multi-channel Transmission Spectrometer"

In a preferred embodiment, the apparatus comprises at least two spectrometer channels, e.g. a multi-channel spectrometer comprising at least two transparent bodies,
30 each of which constitutes said channels.

The multi-channel spectrometer might be realized by positioning the channels in parallel, but the channels can also be placed in continuation of each other in a so-
35 called serial spectrometer.

In a preferred embodiment where the multiple channels are placed in parallel, the light detection means preferably comprises of an array sensor with a separate array for each channel. In contrast hereto, in a serial spectrometer, the different channels illuminate separate parts of the single-array detector.

The advantage of the parallel multi-channel spectrometer is that the sensitivity can be adjusted separately for each channel at the cost of constructing extra electronics.

In contrast hereto, in the serial multi-channel spectrometer, the different channels can not be adjusted individually, but the advantage is that this configuration requires less electronics.

Object Illumination

In a preferred embodiment, the apparatus, e.g. either the transmission spectrometer or the multi-channel spectrometer, further comprises at least one reference light source arranged to illuminate the object.

The object can be illuminated either in a reflection or a transmission mode, which is further described below. The illuminating light can be guided to the object either by free space propagation, e.g. combined with lens arrangements, or via light guiding means, e.g. an optical fiber.

Illumination Mode

In a preferred embodiment, the object is illuminated in a reflection mode, here defined as a mode wherein the object is illuminated on the side facing the spectrometer, i.e. light scattered off or reflected from the object is received by the entrance aperture means of the apparatus. Typical objects illuminated in reflection mode comprise objects that are not transparent to the wavelength bandwidth of the illuminating light, e.g. non-transparent solid surfaces such as printing paper.

In another preferred embodiment, the object is illuminated in a transmission mode, here defined as a mode wherein the object is illuminated on the side not facing the spectrometer, i.e. light transmitted through the object is received by the entrance aperture means of the apparatus. Typical objects illuminated in transmission mode comprise of objects that are transparent to the wavelength bandwidth of the illuminating light, e.g. transparent gases or liquids.

Reference Light Source

Generally, the at least one reference light source should emit polychromatic light in a wavelength range suitable for the application. For visible light applications, preferably the at least one reference light source is a continuous light source or a flash-type light source, preferably a white-light LED or a xenon lamp of either the continuous type or flash type.

Other preferred lamps are tungsten, metal-halide such as mercury-halide, halogen or deuterium lamps. Ambient light can also be used as light source, e.g. sunlight. A series

of narrow-bandwidth light sources can also be used. In a preferred embodiment, a series of LED's is used, where the individual wavelength bandwidths overlap and consequently creates polychromatic light.

5

Reference Channel

In a preferred embodiment, part of the illuminating light is guided to the entrance of at least one of the spectrometer channels via light guiding means or via free space propagation. This channel is here defined as the reference channel.

10
15 In a preferred embodiment, said transparent body comprises at least one measuring part for measuring light from the object and a reference part for measuring light from the at least one reference light source whereby the measurement is independent of variations in the reference
20 light.

In a particularly preferred embodiment at least one spectrometer channel is used to analyze light from the at least one object whereas another spectrometer channel,
25 the reference channel, is used to simultaneously analyze the spectral distribution and intensity of the reference light source used to illuminate the object to be analyzed.

30 This configuration is particularly advantageous because simultaneous readout of reference light source and object provides a means for rapid and more accurate measurements. Additionally, simultaneous measurements of object and reference light make the measurements
35 insensitive to any variation in the reference light used to illuminate the object.

The spectrometer channel used to monitor the reference light can be illuminated with part of the reference light either via optical fiber means or other waveguiding means. In a preferred embodiment, a special base plate is used to guide part of the reference light to the reference channel.

10 Reference Light Correction

In a preferred embodiment the apparatus further comprises means for removing the spectral influence of the reference light in the light measured from the object. The reference light correcting means communicate with the light detection means.

Hereby, object light is measured independent of variations in the reference light.

20 Typical reference light correcting means comprise computing means for determining light intensities of both object light and reference light and calibration procedures including corrections for cross interferences in both channels.

In a preferred embodiment, the ratio of the signal entering the reference channel to the ratio illuminating the object is known, and the reference light correcting means simply accounts for the ratio and subtracts the reference light from the object light.

In another preferred embodiment, the spectrometer undergoes a first calibration with a calibration object, where after the changes of the reference light is monitored in the reference channel. The reference light

correcting means then corrects for the changes in the reference light compared with the reading of reference light taken at the calibration.

5

"Combined Transmission Spectrometer with Distance Sensor"

In a preferred embodiment, the apparatus further comprises a light spot source for illuminating a light spot onto the object; and a distance sensing means for measuring the distance between the object and said entrance aperture means, whereby the spectral information of the object is measured independent of variations in the object distance.

15

Any of the spectrometer geometry's described above can include distance sensing means, but in a preferred embodiment, the distance sensing means is combined with a transmission spectrometer, whereby the distance sensing means can reuse the spectral sensing means.

20

In another preferred embodiment, the distance sensing means is combined with a multi-channel spectrometer, where at least one channel is used as reference channel.

25

Distance Sensing Means

"Light Spot Source"

30

The distance sensing means includes a light spot source for illuminating a light spot onto the object. In a preferred embodiment the light spot source comprises of a monochromatic light source, e.g. a laser diode, or a source with limited wavelength bandwidth, e.g. an LED.

35

"Focusing Means"

In a preferred embodiment the distance sensing means includes means for focusing the light spot on the object onto the spot detection means. The focusing means can
5 either be a refractive optical element, e.g. a lens, or a diffractive optical element.

In a preferred embodiment the focusing means further comprises a wavelength bandpass filter allowing only
10 passage of the light within the bandwidth of the light spot source. Hereby, the amount of object light entering the spectrometer via the focusing means is minimized.

15 *"Spot Detecting Means"*

In a preferred embodiment, the spot detecting means is an array detector or a position sensitive detector.

20 In a particular preferred embodiment, the spot detecting means is the same as the light detecting means, whereby is achieved that the spectral measurement is performed simultaneously with the distance sensing. This geometry is particularly advantageous when the distance sensing
25 means is combined with a transmission spectrometer.

In a preferred embodiment, either the spot size or the spot position is determined on the spot detection means.

30

Converting Spot Size or Spot Position to Object Distance

In a preferred embodiment, the object distance is determined by geometrical magnification, whereas in
35 another preferred embodiment, the object distance is

determined by triangulation. Both methods are well known in the art.

5 Object Distance Correction

In a preferred embodiment the apparatus further comprises means for removing the influence of the object distance in the light measured from the object. The object
10 distance correcting means communicate with the spot detection means.

Hereby, object light is measured independent of variations in object distance.

15

In a preferred embodiment, the changes in object light intensity entering the spectrometer caused by changing object distance is known, and the object distance
20 correcting means simply accounts for the changes when the object distance is known.

In another preferred embodiment the distance sensing means is combined with a multi-channel spectrometer in which at least one channel is used as reference channel.
25 The spectrometer undergoes a first calibration with a calibration object, where the received object intensity is measured at fixed object distances. Here after the changes of the object light versus object distance is known, and the distance correcting means is correcting
30 here fore.

Further Solutions According to the Invention"General Multi-channel Spectrometer"

- 5 In another aspect, the present invention provides an apparatus for measuring spectral information of light from at least one object; said apparatus comprising
- at least one light detecting means; and
- 10 at least one transparent body including:
- an entrance surface having positioned in or near thereof at least one entrance aperture means for receiving light from the at least one object, and
- 15 one or more reflecting surfaces; and
- an exit surface; said exit surface being arranged in a mutual relationship with said at least one light detecting means positioned in or near thereof, or positioned at a distance therefrom, for detecting the reflected light from said one or more reflecting surfaces;
- 25 said one or more reflecting surfaces having at least one diffractive optical element and/or at least one focusing means;
- 30 said at least one transparent body being transparent to the lights from the object and said one or more reflecting surfaces, and
- said at least one transparent body being composed of several parts for measuring light from several objects.
- 35

This apparatus still has the advantage of being compact and easy to position with respect to the objects. It is however not limited to the transmission configuration whereby entrance aperture means and detecting means may
5 be positioned on the same face of the transparent body.

In a preferred embodiment, the several parts for measuring light from several objects comprise at least one measuring part for measuring light from one or more
10 objects and a reference part for measuring light from a reference light source.

Preferred embodiments including the same features for this aspect of the invention are similar to those
15 described in the present general and detailed description including the examples. In particular, the features of the embodiments described in the sections "Transmission Spectrometer", "Multi-channel Transmission Spectrometer" and "Transmission Spectrometer with Distance Sensor",
20 hereby included here by reference.

"General Spectrometer with Distance Sensor"

25 In another aspect, the present invention provides an apparatus for measuring spectral information of light from at least one object; said apparatus comprising

at least one light detecting means;

30

at least one light spot source for illuminating a light spot onto the at least one object; and

35

at least one transparent body; said body including:

an entrance surface having positioned in or near thereof at least one entrance aperture means for receiving light from the object, and

5 one or more reflecting surfaces; and

an exit surface; said exit surface being arranged in a mutual relationship with said at least one light detecting means; said detecting means being
10 positioned in or near thereof, or positioned at a distance therefrom, for detecting the reflected light from said one or more reflecting surfaces; and

distance sensing means for measuring the distance between
15 the at least one object and said entrance aperture means;

said one or more reflecting surfaces having at least one diffractive optical element and/or at least one focusing means; and

20 said at least one transparent body being transparent to the lights from the object and said one or more reflecting surfaces.

25 This apparatus has the advantage of correcting for influences of distance variations from the apparatus to the at least one object.

Preferred embodiments including the same features for
30 this aspect of the invention are similar to those described in the present general and detailed description including the examples. In particular, the features of the embodiments described in the sections "Transmission Spectrometer", "Multi-channel Transmission Spectrometer"
35 and "Transmission Spectrometer with Distance Sensor", hereby included here by reference.

"General Multi-channel Spectrometer with Distance Sensor"

In another aspect, the present invention provides an apparatus for measuring spectral information of light
5 from at least one object; said apparatus comprising

at least one light detecting means;

10 at least one light spot source for illuminating a light spot onto the at least one object;

at least one transparent body including:

15 an entrance surface having positioned in or near thereof at least one entrance aperture means for receiving light from the at least one object, and

one or more reflecting surfaces; and

20 an exit surface; said exit surface being arranged in a mutual relationship with said at least one light detecting means positioned in or near thereof, or positioned at a distance therefrom, for detecting the reflected light from said one or more reflecting
25 surfaces;

said one or more reflecting surfaces having at least one diffractive optical element and/or at least one focusing means; and

30 distance sensing means for measuring the distance between the at least one object and said entrance aperture means;

35 said at least one transparent body being transparent to the lights from the object and said one or more reflecting surfaces, and

said at least one transparent body being composed of several parts for measuring light from several objects.

5 In a preferred embodiment, the several parts for measuring light from several objects comprise at least one measuring part for measuring light from one or more objects and a reference part for measuring light from a reference light source.

10

In addition to the advantages of compactness of the general multi-channel spectrometer described above, this apparatus has the advantage of correcting for influences of distance variations to the object or objects. This is particularly advantageous since multi-channel spectrometers generally do not include this correction.

15

Preferred embodiments including the same features for this aspect of the invention are similar to those described in the present general and detailed description including the examples. In particular, the features of the embodiments described in the sections "Transmission Spectrometer", "Multi-channel Transmission Spectrometer" and "Transmission Spectrometer with Distance Sensor", hereby included here by reference.

20

25

"Methods of Spectral Measurements"

30 In another aspect, the present invention provides an apparatus for measuring spectral information of light from at least one object; said method comprising:

measuring light from at least one object by an apparatus comprising light detection means and at least one transparent body according to the invention;

35

said method further comprising:

5 illuminating the at least one object by light from at least one reference light source;

10 simultaneously, measuring object light from the illuminated objects in at least one measuring channel and measuring reference light from the at least one reference light source in at least one reference channel; and

removing spectral influence of the reference light in the measured light from the object.

15 In a preferred embodiment, the spectral influence of the reference light in the object light is removed by subtracting the measured reference light from the measured object light.

20 In another preferred embodiment, the spectral influence of the reference light in the object light is removed by correcting for changes in the reference light compared to a reference measurement taken at a first calibration.

25 In still another preferred embodiment, the method further comprising the steps of:

illuminating light from a light spot source onto the object;

30 focusing light from the light spot on the object onto the spot detection means; and

35 determining the spot size or the spot position on said spot detection means; and

determining the distance to the object, preferably by geometrical magnification or by triangulation.

5 It is particularly advantageous to measure the spectral distribution of multiple objects, thus allowing parallel and fast measurements. Additionally, it is advantageous to measure the spectral distributions of at least one object independently of variations in reference light and variations in object distance. Particularly if the object
10 is illuminated by flash type illumination means, e.g. a xenon flash tube, the object light vary from flash to flash.

"Methods of Spectral Measurements - Distance Sensing"

15 In another aspect, the present invention provides an apparatus for measuring spectral information of light from at least one object; said method comprising:

20 measuring light from at least one object by an apparatus comprising light detection means and at least one transparent body according to the invention;

said method further comprising:

25 correcting the influence of distance between the objects and the apparatus on the measured object light;

said correction comprising measuring said distance by:

30 illuminating light from a light spot source onto the object;

35 focusing light from the light spot on the object onto the spot detection means;

determining the spot size or the spot position on said spot detection means; and

5 determining the distance to the object, preferably by geometrical magnification or by triangulation.

Hereby, it is possible to measure the spectral distribution of the object independent of variations in object distance, which is particularly useful e.g. when
10 measuring color in printing devices where the distance between the light entrance means and the printer paper can vary.

15 3. BRIEF DESCRIPTION OF THE DRAWINGS

In the following, the invention is further disclosed with detailed description of preferred embodiments, reference
20 being made to the drawings in which

Fig. 1 shows a cross-sectional sketch of the optical layout of a conventional spectrometer

Fig. 2 shows a three dimensional sketch of the optical
25 layout for a prior art compact spectrometer made in a monolithic material.

Fig. 3 shows a preferred embodiment of the present invention in which the ray-tracing simulations are
30 illustrated.

Fig. 4 shows a preferred embodiment of the present invention in which the ray-tracing simulations are illustrated for an apparatus with multiple reflective
35 surfaces leading to improved resolution.

Fig. 5A shows a three dimensional sketch of a preferred embodiment in which the apparatus comprises parallel front sides and back sides.

5 Fig. 5B shows a cross-sectional sketch of the preferred embodiment shown in Fig. 5A in which the reflecting surfaces are placed below the respective surfaces of the front side and back side.

10 Fig. 6 shows a three dimensional sketch of a preferred embodiment in which the apparatus is a composed body in which light absorbing material is positioned inside the composed body.

15 Fig. 7 shows a three dimensional sketch of a preferred embodiment in which the apparatus consists of two parallel spectrometer channels.

20 Fig. 8 shows a three dimensional sketch of a preferred embodiment in which one spectrometer channel is combined with distance sensing means.

25 Fig. 9 shows a three dimensional sketch of a preferred embodiment in which two parallel spectrometer channels are combined with a distance sensing means.

30 Fig. 10 shows a cross-sectional sketch of a preferred embodiment, in which two parallel spectrometer channels are combined with a distance sensing means. In addition, a base plate containing focusing means for the distance sensing means a guiding means for the reference light is included. This preferred embodiment is used to perform the measurements used in examples 1-3.

35 Fig. 11 shows a three dimensional sketch of the base plate used in Fig. 10.

Fig. 12 shows a three dimensional sketch of a preferred embodiment, in which two parallel spectrometer channels are combined with a distance sensing means. In addition, a base plate containing focusing means for the distance sensing means, a guiding means for the reference light is included. In this preferred embodiment, all reflective surfaces are placed below the respective surfaces of the front side and back side of the spectrometer and the base plate.

10

Fig. 13 shows a plot of measured spectral distribution of reference light source in said reference channel and a plot of measured spectral distribution of object and distance-sensing means in said measurement channel.

15

Fig. 14 shows a plot of measured spectral distributions of an orange color calibration tile including distance-sensing means taken at two different object distances.

20 Fig. 15 shows a plot of measured reflectance from an orange color calibration tile, said measured reflection and its dependence on variations in object distance before and after the distance sensing means corrects for variations in object distance. For comparison, the theoretical reflection curve is included too.

25

4. DETAILED DESCRIPTION

Conventional Spectrometer - Prior Art

5 The optical layout of a typical conventional spectrometer is shown in Fig. 1. A source 10 of light is typically a slit or an aperture illuminated by light from an object 15 positioned at a distance d therefrom. Light from the source passes to a first parabolic mirror 11, which
10 produces and directs a plane wave towards a diffractive means 12, e.g. grating. The diffracted plane wave is collected by a second parabolic mirror 13, which reflects the light and focuses an image of the source onto a detector 14. Since the angle of diffraction of the light
15 from the diffractive means varies with wavelength, the spectrometer effectively produces an infinite number of images, each at different wavelength, spread across the plane of the detecting means. In a conventional spectrometer, the relative alignment of the slit,
20 mirrors, grating, and detector is crucial to the reliability of the spectrometer. Commonly, the detector can only measure one wavelength at a time. Consequently, measurement of other wavelengths or the bandwidth of a spectral line requires physical movement of the grating.

25

Compact Spectrometers - Prior Art

With improved detector technology, spectrometers using
30 linear detector arrays can measure simultaneously the intensities at multiple wavelengths. Consequently, no moving parts are necessary in the spectrometer. The optical layout of a typical prior art compact, monolithic spectrometer 25 is shown in Fig. 2. A source 20 of light
35 is typically a slit or aperture illuminated by light from an object 15 positioned at a distance d therefrom. Light

from the source passes to a first parabolic mirror 21, which produces and directs a plane wave towards a diffraction grating 22. The diffracted plane wave is collected by a second parabolic mirror 23 which reflects
5 the light and focuses an image of the source onto a linear detector array 24. Since the angle of diffraction of the light from the diffraction grating varies with wavelength, the spectrometer effectively produces an infinite number of images, each at different wavelength,
10 spread across the plane of the detector.

Preferred Embodiments

15 Ray-Tracing Simulation of a Compact Transmission Spectrometer

Fig. 3 shows a cross-sectional sketch of a ray-tracing simulation of a single channel including a transparent
20 body 31 in a preferred transmission spectrometer embodiment. A light source 38 illuminates the object 15 positioned in front F of the transparent body 31. The object is positioned the distance d from the entrance aperture means 30, positioned at the entrance surface
25 311. In this example the entrance aperture means comprises of a rectangular slit. Inside the transparent body 31 the light propagates towards a reflecting surface 313 of the back side at which a diffractive optical element 32 (here a blazed grating) diffracts the light
30 towards a reflective surface 312 of the front side, in this preferred embodiment an aspheric mirror 33. The aspheric mirror focuses the diffracted wavelengths across the plane of the light detecting means 34, in this example comprising of an array detector and placed
35 opposite the entrance means at the back side B of the transparent body. The light detecting means is placed at

a distance from the exit surface 314, which is tilted to correct for chromatic aberrations.

5 Ray-Tracing Simulation of Compact Transmission Spectrometer with Multiple Reflective Surfaces and Parallel Front Side and Back Side

10 Fig. 4 shows a cross-sectional sketch of a ray-tracing simulation of a single channel including a transparent body 31 in a preferred transmission spectrometer embodiment. A light source 38 illuminates the object 15 positioned in front F of the transparent body 31. The object is positioned the distance d from the entrance aperture means 30, positioned at the entrance surface 15 311a. In this example the entrance aperture means comprises of a rectangular slit. Inside the transparent body 31, the light propagates towards a further reflecting surface 313b of the back side at which a planar mirror 35a directs the light towards a further 20 reflective surface 312b of the front side at which a planar mirror 35b directs the light towards the reflective surface 313a of the back side, at which a diffractive optical element 32 (here a blazed grating) 25 diffracts the light towards the reflective surface 312a of the front side, in this preferred embodiment an aspheric mirror 33. The aspheric mirror focuses the diffracted wavelengths across the plane of the light detecting means 34, in this example comprising of an 30 array detector and placed opposite the entrance means at the back side B of the transparent body. The light detecting means is placed at a distance from the exit surface 314a.

35 In this preferred embodiment the diffractive optical element 32 and the detecting means 34 are arranged in

parallel planes or coinciding planes. Also, the entrance surface 311a and the exit surface 314a are parallel.

Other preferred transmission spectrometer geometry's will be shown in the following, but will not be substantiated by ray-tracing simulations.

Compact Spectrometer with Optical Elements Positioned Below the Respective Surfaces of the Front Side and Back Side

Fig. 5A shows a three dimensional sketch of a preferred embodiment in which the reflective surfaces (i.e., the planar mirrors 35a, 35b, the diffractive optical element 32, and the aspheric mirror 33) are positioned below the respective surfaces of the front side and back side. This is clearly illustrated in Fig. 5B, which shows a cross-sectional sketch taken at the plane C from Fig. 5A.

The principle of the ray-tracing simulations is illustrated in Fig. 4 with the exception that that the aspheric mirror 33 now focus the diffracted wavelengths across the detecting means 34 which is now positioned at the exit surface.

Composed Compact Spectrometer with Light Absorbing Material into Said Body

Fig. 6 shows a three dimensional sketch of a preferred embodiment in which the spectrometer body is a composed body (31a, 31b) and in which light absorbing material 315 is placed between said composed bodies. The spectrometer is similar to the transmission spectrometer illustrated in Fig. 5 and described above.

The composed body comprising a front part 31a and a back part 31b. The front part is incorporating an entrance aperture means 30, a further planar mirror 35b, and the focusing means 33. The back part is incorporating a further planar mirror 35a, the diffractive optical element, and the exit surface.

This preferred embodiment is composed of two parts (31a, 31b).

10

In another preferred embodiment, the transparent composed body further comprises an intermediate part.

Compact Dual Channel Spectrometer

15

Fig. 7 shows a three dimensional sketch of a preferred embodiment that consists of two parallel spectrometer channels. In the preferred embodiment shown in Fig. 7, the dual channel spectrometer comprises of a measurement channel 41a to measure light from the object 15 and a reference channel 41b to measure light from the reference light source 38 (not shown in Fig. 7). The light enters each spectrometer channel through an aperture, in this example rectangular slits (40a, 40b), and each channel is an independent transmission spectrometer working according to the ray-tracing simulation illustrated in Fig.3 with the exception that that the aspheric mirrors (43a, 43b) now focus the diffracted wavelengths across the detecting means (44a, 44b) which is now positioned at the exit surface.

30

The light from the measurement channel 41a is focused onto the light detecting means 44a whereas the light from the reference channel is focused onto the light detecting means 44b.

35

Preferably the detecting means (44a, 44b) comprises of a dual line sensor, said line comprising of an array sensor. In this example the array sensor is a dual line sensor of 2x256 pixels (S4801-256Q), from Hamamatsu Photonics, JP.

An illustration of simultaneous measurement of object light and reference light is shown in Example 1.

10

Compact Spectrometer Unit Combined with Distance Sensing Means

Fig. 8 shows a three dimensional sketch of a preferred embodiment in which one spectrometer channel 31 is combined with a distance sensing means. The spectrometer channel is similar to the transmission spectrometer illustrated in Fig. 7 and described above.

The distance sensing means preferably comprises of a light spot source 51 for focusing a light spot 53 onto said object 15. A focusing means 52 is integrated within the compact spectrometer unit 31 and focuses the light spot from the object onto said spot detecting means 44c. In this preferred embodiment, the light detecting means and the spot detecting means is combined in a single detecting means 44c.

For the preferred embodiment shown in Fig. 8, the light spot source 51 illuminates the object 15 under an angle. If the object distance is changed, the position of the illuminated light spot on the spot detecting means 44c is displaced in the longitudinal direction of the detecting means. I.e., the object distance is determined by triangulation.

An illustration of simultaneous measurement of object light and spot position for two different object distances is shown in Example 2.

5

Compact Dual Channel Spectrometer with Distance Sensing Means

10 Fig. 9 shows a three dimensional sketch of another preferred embodiment in which a dual channel spectrometer is combined with a distance sensing means. That is a combination of the preferred embodiments illustrated in Figs. 7 and 8 respectively.

15 Figure 10 shows another cross-sectional sketch of a preferred embodiment in which a dual channel spectrometer is combined with a distance sensing means. This embodiment has been used for the examples described below, and includes additionally a base plate 61 that
20 guides part of the reference light 68 to the reference channel. Additionally, the base plate contains the focusing means 62 for the distance sensing means. The base plate 61, spectrometer unit 41, and detecting means 44 are aligned with respect to each other in a specially
25 fabricated box (not shown here).

A three dimensional sketch of the base plate 61 is illustrated in Fig. 11. Part of the reference light used to illuminate the object enters the base plate 61 via an
30 entrance aperture 65. A double-sided mirror coating 66 ensures that the light is multiple reflected (see the illustration of the light rays 68 in Figs. 10 and 11) to a prism with a mirror coating 64. The mirror 64 ensures that the reference light is reflected through the
35 entrance aperture means 60 (here placed on the base plate 61) into the spectrometer reference channel.

Additionally, the base plate 61 contains the focusing means 62 for the distance sensing means. In order not to allow passage of object light through the distance sensing entrance a wavelength bandpass filter 63 allowing only the narrow wavelength bandwidth of the light spot source (not shown here) for the distance sensing means to be transmitted.

A ray trace of the light for the distance sensing means 67 is shown in Fig. 10. For this preferred embodiment, a prism 45 is used to bend the focused light for the distance sensing means to the same detection means 44 as is used to analyze the light from the object. By choosing an array sensor as detection means, the spectrometer can use part of the array sensor as spectral sensing means whereas the distance sensing means use the remaining part of the array sensor as spot detection means.

20 All planar Dual Channel Spectrometer with Distance Sensing Means and Reference Light Providing Means

Fig. 12 shows a three dimensional sketch of another preferred embodiment in which a dual channel spectrometer is combined with a distance sensing means. This preferred embodiment is a planar version of the embodiment illustrated in Figs. 10 and 11. In this preferred embodiment, all reflective surfaces are placed below the respective faces of the front side and back side of the spectrometer and the base plate.

5. EXAMPLES

35 The invention is further illustrated by the following instructive examples.

Example 1 "Simultaneous determination of spectral distribution from the object and the reference light source"

5 An apparatus according to the one shown in Fig. 10 was provided where the object was illuminated by a reference light source at an angle of 45 degrees. The object was a calibrated white tile from NPL, UK. The object distance d was 15 mm and the object was illuminated with a xenon
10 light source. The signals are read from the two channels in the array sensor (S4801-256 from Hamamatsu Photonics, JP). Fig. 13 shows the intensity I in arbitrary units versus pixel number N . The solid line S represents the spectral distribution of the reference light source and
15 the dashed line D represents the spectral distribution read from the white object. The pixel numbers are converted to wavelengths by computing means. Note that the spectral distributions only cover pixels 150-256 whereas the remaining pixels (see dashed line D), in
20 particular 0-100, are used by the distance sensing means described in Example 2.

25 Example 2 "Simultaneous determination of spectral distribution of the object and object distance"

An apparatus according to the one used in example 1 was provided in which the light spot source (VCSEL SV 4631-001 from Honeywell, US) emitting at 850 nm is focused
30 onto the object under an illumination angle of 40 degrees. A wavelength bandpass filter 63 (JENOFILT 804 CWL-850) was combined with the focusing means 62 on said base plate 61. By illumination of the object via an angle, the triangulation principle is used to determine
35 the object distance. Fig. 14 shows intensity I in arbitrary units versus pixel number N . Measurements are

performed at object distances of 14 mm and 16 mm respectively. It is clearly seen that changing the object distance cause displacement of the spot position on said spot detecting means. The spot position is determined by
5 determining the pixel at which the pixel intensity attains its maximum. Converting the spot position to object distance by triangulation is known in the art.

10 Example 3 "Determination of object reflectance including correction for variation in object distance"

Determination of object distance is particularly advantageous in applications where colour has to be
15 measured from solid surfaces, e.g., paper. Varying the object distance changes the total amount of intensity that reaches the detecting means and consequently, the measured colour density vary with varying object distance. By use of the distance sensing means described
20 in example 2, the variation in intensity caused by variations in object distance is corrected. In Fig. 15 showing reflectance R versus wavelength λ [nm], the theoretical reflection curve is shown for a calibrated orange tile from NPL, UK (solid curve). The spectrometer
25 is calibrated at an object distance of 14 mm. From the figure, it can be seen that the measurements performed at $d=14$ mm (dashed curve) fit the theoretical curve. The object distance is now changed to $d=16$ mm. Without distance correcting means, it can be seen that the
30 measurements (dashed-dotted curve) do not fit the theoretical curve whereas the measurements agree well with the theory when the distance correcting algorithm is applied (dotted curve). The distance correcting algorithm is applied by computing means.

35

SPECTROMETER

CLAIMS

5

1. An apparatus for measuring spectral information of light from at least one object (15); said apparatus comprising

10 at least one light detecting means (34); and

at least one transparent body (31) having a front side (F) and a back side (B);

15 said front side including:

an entrance surface (311) having positioned in or near thereof at least one entrance aperture means (30) for receiving light from the at least one
20 object, and

at least one reflecting surface (312); and

said back side including:

25

at least one other reflecting surface (313) for reflecting light received from said at least one entrance aperture means to said at least one reflecting surface of the front side, and

30

an exit surface (314); said exit surface being arranged in a mutual relationship with said at least one light detecting means (34); said detecting means being positioned in or near thereof, or positioned at
35 a distance therefrom, for detecting the reflected

light from said at least one reflecting surface of the front side;

5 said at least one other reflecting surface of the back side, said at least one reflecting surface of the front side, or both, having at least one diffractive optical element (32) and/or at least one focusing means (33);

10 said at least one diffractive element and said at least one focusing means being arranged so that the transmitted light is diffracted before being focused; and

15 said at least one transparent body being transparent to the lights from the object, said other reflecting surface of the back side, and said reflecting surface of the front side.

2. The apparatus according to claim 1 wherein the apparatus further comprises aberration correcting means.

20

3. The apparatus according to claim 2 wherein the aberration correcting means is selected from the group consisting of an aspheric focusing means, a tilted exit surface, an aspheric exit surface, and a combination thereof.

25

4. The apparatus according to any one of claims 1-3 wherein the front side includes:

30 at least one further reflecting surface (312b); and

the said back side includes:

at least one further reflecting surface (313b);

35

said further reflecting surfaces being arranged to reflect light more times before being received by the at least one focusing means (33), the at least one diffractive means (32), or both.

5

5. The apparatus according to any one of claims 1-4 wherein the at least one diffractive optical element (32), the at least one focusing means (33), the reflecting surfaces (312b, 313b) or all, are positioned
10 above and/or below the respective surfaces of the front side and back sides of the at least one transparent body.

6. The apparatus according to any one of claims 1-5 wherein the at least one diffractive optical element (32)
15 and the detection means (34) are arranged in parallel planes or coinciding planes.

7. The apparatus according to any one of claims 1-6 wherein the entrance surface (311a) and the exit surface
20 (314a) are parallel.

8. The apparatus according to any one of claims 1-7 wherein the entrance aperture means consists of a
25 rectangular slit.

9. The apparatus according to any one of claims 1-8 wherein the entrance aperture means is constituted by an
optical fiber means.

30 10. The apparatus according to any one of claims 1-9 wherein the at least one diffractive optical element is aspheric.

35 11. The apparatus according to any one of claims 1-10 wherein the focusing means is aspheric.

12. The apparatus according to any one of claims 1-11
wherein the at least one light detecting means is
positioned at a distance from the surface of the exit
5 surface of the at least one transparent body.

13. The apparatus according to any one of claims 1-12,
wherein the at least one light detecting means is
positioned below or above the surface of the exit surface
10 of the at least one transparent body.

14. The apparatus according to any one of claims 1-13
wherein said at least one transparent body is a unitary
body (31), or a composed body (31a,31b).

15
15. The apparatus according to claim 14 wherein said
transparent body is a composed body (31a,31b) comprising
a front part, a back part, and optionally an intermediate
part; said front part incorporating said entrance
20 aperture means (30), said at least one diffractive
optical element (32) and/or said at least one focusing
means (33); and said back part incorporating said exit
face, said at least one diffractive optical element (32)
and/or said at least one focusing means (33).

25
16. The apparatus according to claim 15 wherein said
optionally intermediate part consists of a material
selected from the group consisting of a low cost
transparent material, a thermally stable transparent
30 material, and a filtering material, or a combination
thereof.

17. The apparatus according to claims 14-16, wherein said
unitary or composed body is fabricated by means of
35 replication.

18. The apparatus according to any one of claims 1-17 wherein said at least one transparent body is covered by light absorbing material.
- 5 19. The apparatus according to claim 18 wherein said light absorbing material has a refractive index identical to the refractive index of said at least one transparent body.
- 10 20. The apparatus according to any one of claims 18 or 19 wherein said light absorbing material is coated onto said at least one transparent body.
- 15 21. The apparatus according to any one of claims 1-20 wherein said light absorbing material is molded into said at least one transparent body.
- 20 22. The apparatus according to any one of claims 1-20 wherein said light absorbing material (315) is positioned inside said at least one transparent body.
23. The apparatus according to any one of claims 1-22 comprising at least two spectrometer channels (41a, 41b).
- 25 24. The apparatus according to claim 23 wherein said the at least two spectrometer channels are parallel.
- 30 25. The apparatus according to claim 23 wherein said at least two spectrometer channels are placed in continuation of each other.
26. The apparatus according to any one of claims 1-25 further comprising at least one reference light source (38) for illumination of the object (15) to be measured.

35

27. The apparatus according to claim 26 wherein said at least one reference light source (38) illuminates the object (15) in a reflection configuration.
- 5 28. The apparatus according to claim 26 wherein said at least one reference light source (38) illuminates the object (15) in a transmission configuration.
- 10 29. The apparatus according to any one of claims 1-28 wherein said body comprises at least one measuring part (41a) for measuring light from the object and a reference part (41b) for measuring light from the at least one reference light source.
- 15 30. The apparatus according to claim 29 wherein said part of the reference light (38) is guided to said reference channel (41b) by a guiding plate (61).
- 20 31. The apparatus according to claim 29 wherein said part of the reference light (38) is guided to said reference channel (41b) by optical fiber means.
- 25 32. The apparatus according to any of claims 29-31 further comprising means for removing spectral influence of the reference light in the measured light from the at least one object which means communicates with light detection means for the at least one measuring part and with light detection means for the reference part of said body.
- 30 33. The apparatus according to any one of claims 1-32 further comprising a light spot source (51) for illuminating a light spot (53) onto the object; and a distance sensing means for measuring the distance between
- 35 the object and said entrance aperture means.

34. The apparatus according to claim 33 wherein the light spot source is a monochromatic light source, preferably a laser or a LED with limited bandwidth.
- 5 35. The apparatus according to any one of claims 33-34 wherein said distance sensing means includes means (52) for focusing a light spot (53) from the object onto the spot detection means (44c).
- 10 36. The apparatus according to claim 35 wherein the focusing means (52) comprises a wavelength bandpass filter (63) allowing only passage of light within the bandwidth of the light spot source (51).
- 15 37. The apparatus according to any one of claims 33-36 wherein said distance sensing means further include means for determining the spot size on said spot detection means, and/or means for determining the position of the imaged spot on said spot detection means (44c).
- 20 38. The apparatus according to any one of claims 33-37 wherein the said spot detection means (44c) is a position sensitive detector or an array detector.
- 25 39. The apparatus according to any one of claims 33-38 wherein said distance sensing means further include distance converting means for converting either the spot size or the spot position on the spot detection means to a distance to the object, preferably by geometrical
- 30 magnification or by triangulation.
40. The apparatus according to any one of claims 33-39 further comprising means for removing the influence of the varying object distance in the measured light from
- 35 the object.

41. An apparatus for measuring spectral information of light from at least one object (15); said apparatus comprising

5 at least one light detecting means (34); and

at least one transparent body (31) including:

10 an entrance surface (311) having positioned in or near thereof at least one entrance aperture means (30) for receiving light from the at least one object, and

15 one or more reflecting surfaces (312,313); and

an exit surface (314); said exit surface being arranged in a mutual relationship with said at least one light detecting means (34) positioned in or near thereof, or positioned at a distance therefrom, for
20 detecting the reflected light from said one or more reflecting surfaces;

25 said one or more reflecting surfaces having at least one diffractive optical element (32) and/or at least one focusing means (33);

30 said at least one transparent body being transparent to the lights from the object and said one or more reflecting surfaces, and

said at least one transparent body being composed of several parts for measuring light from several objects.

35 42. The apparatus as claimed in claim 41 wherein the several parts for measuring light from several objects comprise at least one measuring part (41a) for measuring

light from one or more objects and a reference part (41b) for measuring light from a reference light source.

43. An apparatus for measuring spectral information of
5 light from at least one object (15); said apparatus comprising

at least one light detecting means (34);

10 at least one light spot source (51) for illuminating a light spot onto the at least one object; and

at least one transparent body (31); said body including:

15 an entrance surface (311) having positioned in or near thereof at least one entrance aperture means (30) for receiving light from the object, and

one or more reflecting surfaces (312,313); and

20

an exit surface (314); said exit surface being arranged in a mutual relationship with said at least one light detecting means (34); said detecting means being positioned in or near thereof, or positioned at
25 a distance therefrom, for detecting the reflected light from said one or more reflecting surfaces; and

distance sensing means for measuring the distance between the at least one object and said entrance aperture means;

30

said one or more reflecting surfaces having at least one diffractive optical element (32) and/or at least one focusing means (33); and

said at least one transparent body being transparent to the lights from the object and said one or more reflecting surfaces.

5 44. An apparatus for measuring spectral information of light from at least one object (15); said apparatus comprising

at least one light detecting means (34);

10

at least one light spot source (51) for illuminating a light spot onto the at least one object;

at least one transparent body (31) including:

15

an entrance surface (311) having positioned in or near thereof at least one entrance aperture means (30) for receiving light from the at least one object, and

20

one or more reflecting surfaces (312,313); and

an exit surface (314); said exit surface being arranged in a mutual relationship with said at least one light detecting means (34) positioned in or near thereof, or positioned at a distance therefrom, for detecting the reflected light from said one or more reflecting surfaces;

25

30 said one or more reflecting surfaces having at least one diffractive optical element (32) and/or at least one focusing means (33); and

35 distance sensing means for measuring the distance between the at least one object and said entrance aperture means;

said at least one transparent body being transparent to the lights from the object and said one or more reflecting surfaces, and

5 said at least one transparent body being composed of several parts for measuring light from several objects.

45. The apparatus as claimed in claim 44 wherein the several parts for measuring light from several objects
10 comprise at least one measuring part (41a) for measuring light from one or more objects and a reference part (41b) for measuring light from a reference light source.

46. A method of measuring spectral information of light
15 from at least one object (15), said method comprising:

measuring light from at least one object by an apparatus comprising light detection means and at least one transparent body as defined in any one of the preceding
20 claims;

said method further comprising:

illuminating the at least one object by light from at
25 least one reference light source (38);

simultaneously, measuring object light from the illuminated objects in at least one measuring channel (41a) and measuring reference light from the at least one
30 reference light source in at least one reference channel (41b); and

removing spectral influence of the reference light in the measured light from the object.

35

47. A method according to claim 46, wherein the spectral influence of the reference light in the object light is removed by subtracting the measured reference light from the measured object light.

5

48. A method according to claim 46, wherein the spectral influence of the reference light in the object light is removed by correcting for changes in the reference light compared to a reference measurement taken at a first calibration.

10

49. A method according to any one of claims 46-48, further comprising the steps of:

15 illuminating light from a light spot source onto the object;

focusing light from the light spot on the object (53) onto the spot detection means (44c); and

20

determining the spot size or the spot position on said spot detection means; and

determining the distance to the object, preferably by geometrical magnification or by triangulation.

25

50. A method of measuring spectral information of light from at least one object (15), said method comprising:

30 measuring light from at least one object by an apparatus comprising light detection means and at least one transparent body as defined in any one of the preceding claims;

35 said method further comprising:

correcting the influence of distance between the objects and the apparatus on the measure object light;

said correction comprising measuring said distance by:

5

illuminating light from a light spot source onto the object;

10

focusing light from the light spot on the object onto the spot detection means (44c);

determining the spot size or the spot position on said spot detection means; and

15

determining the distance to the object, preferably by geometrical magnification or by triangulation.

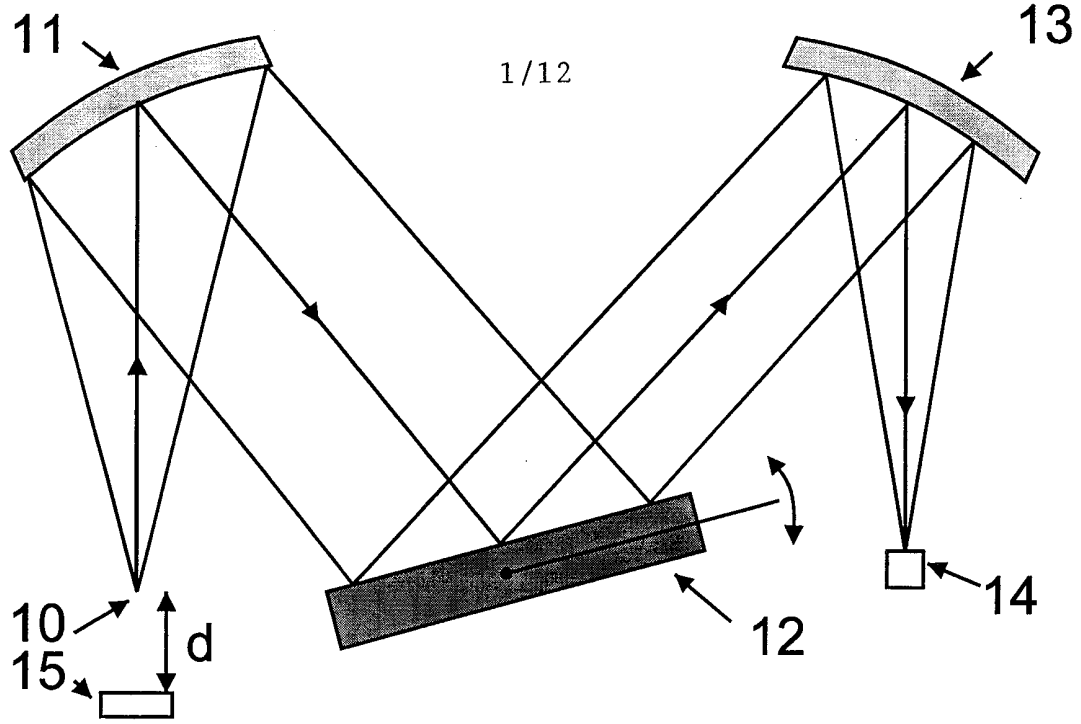

Figure 1

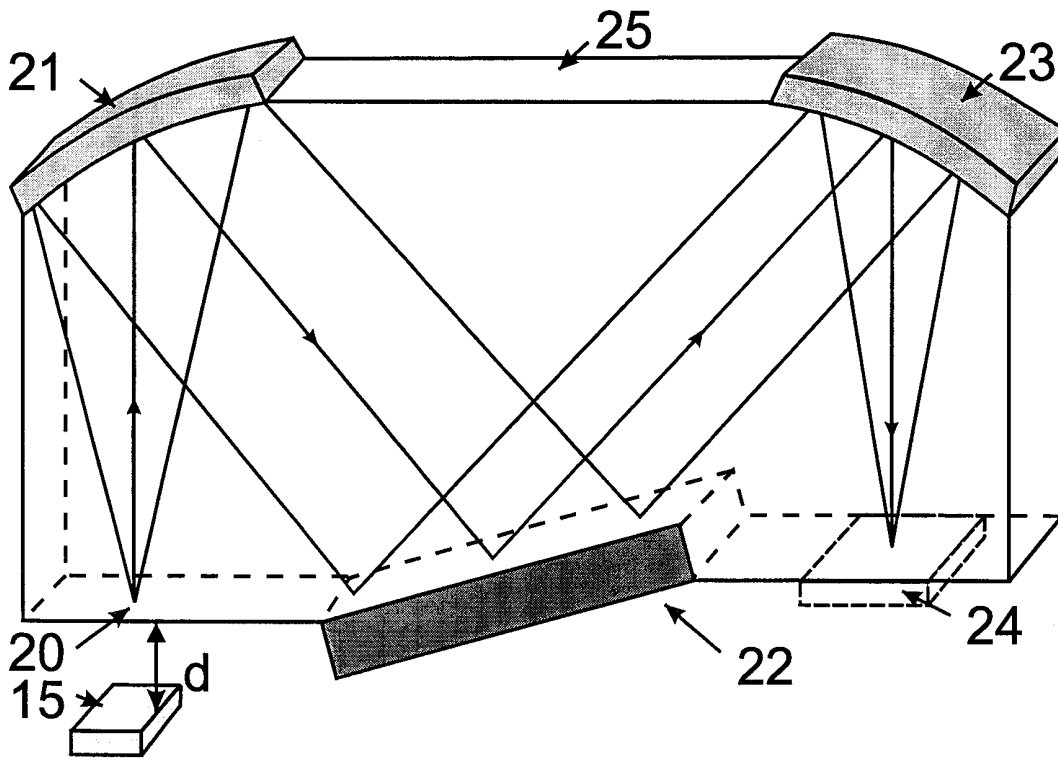

Figure 2

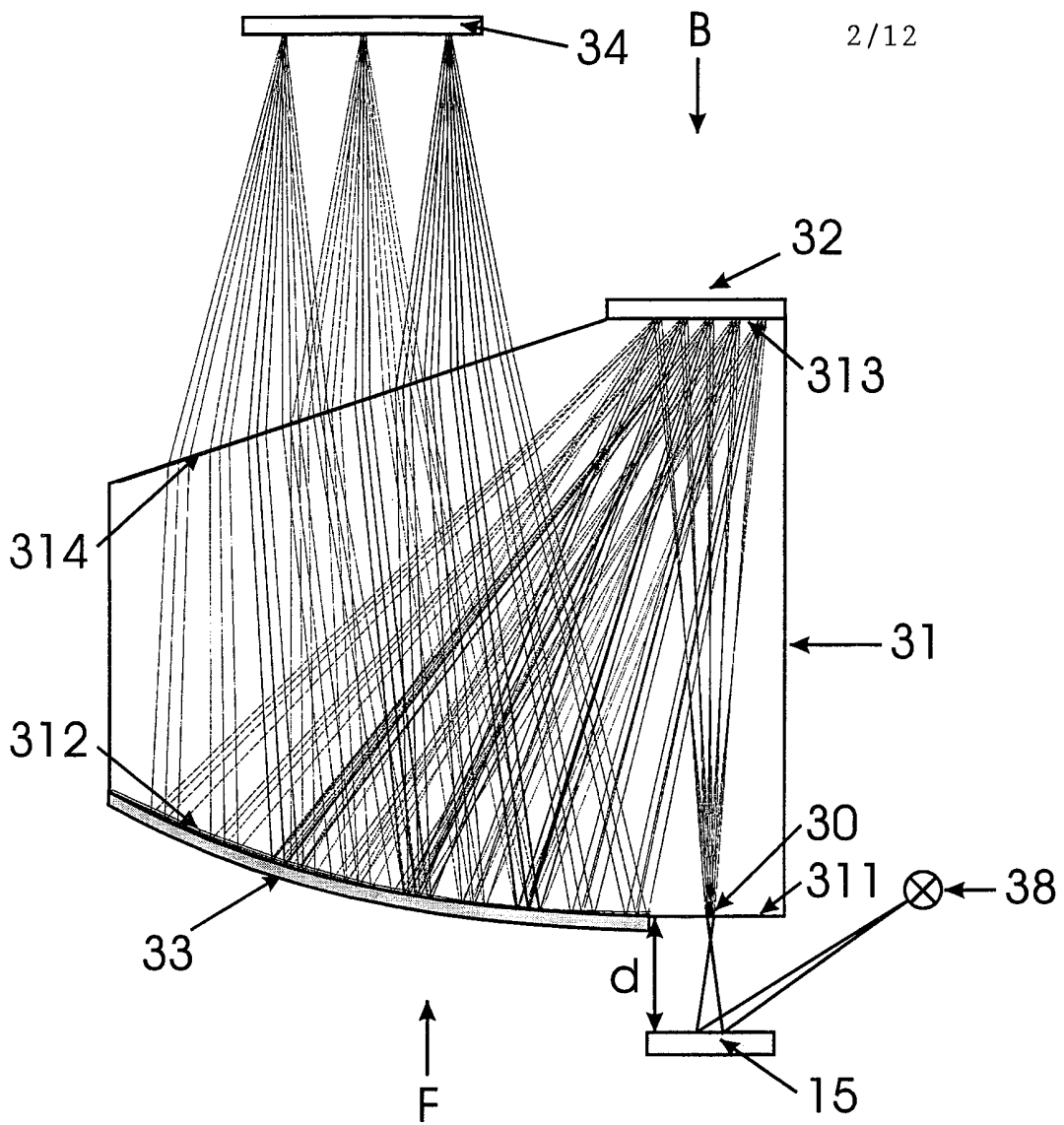

Figure 3

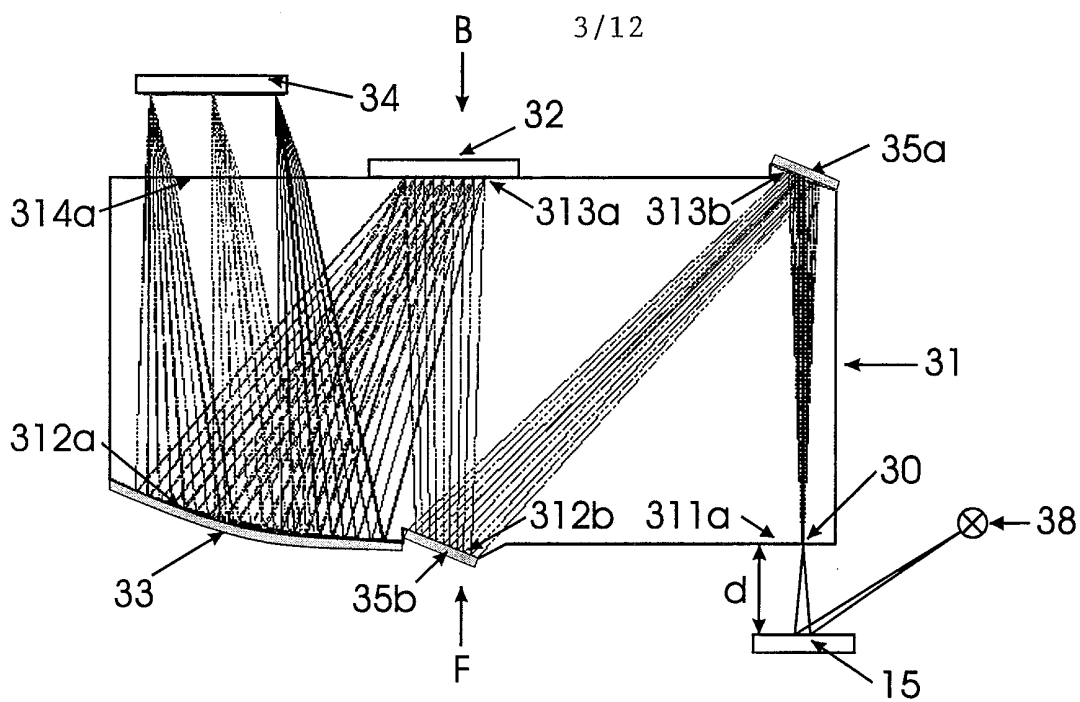
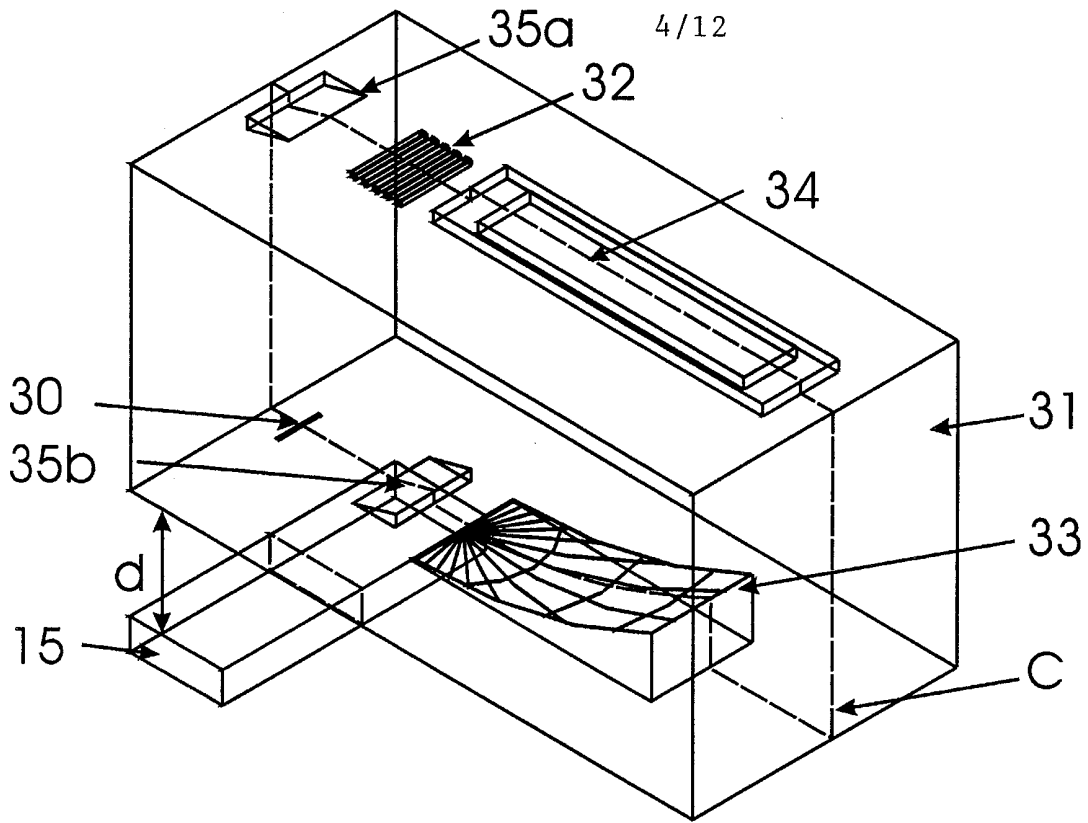
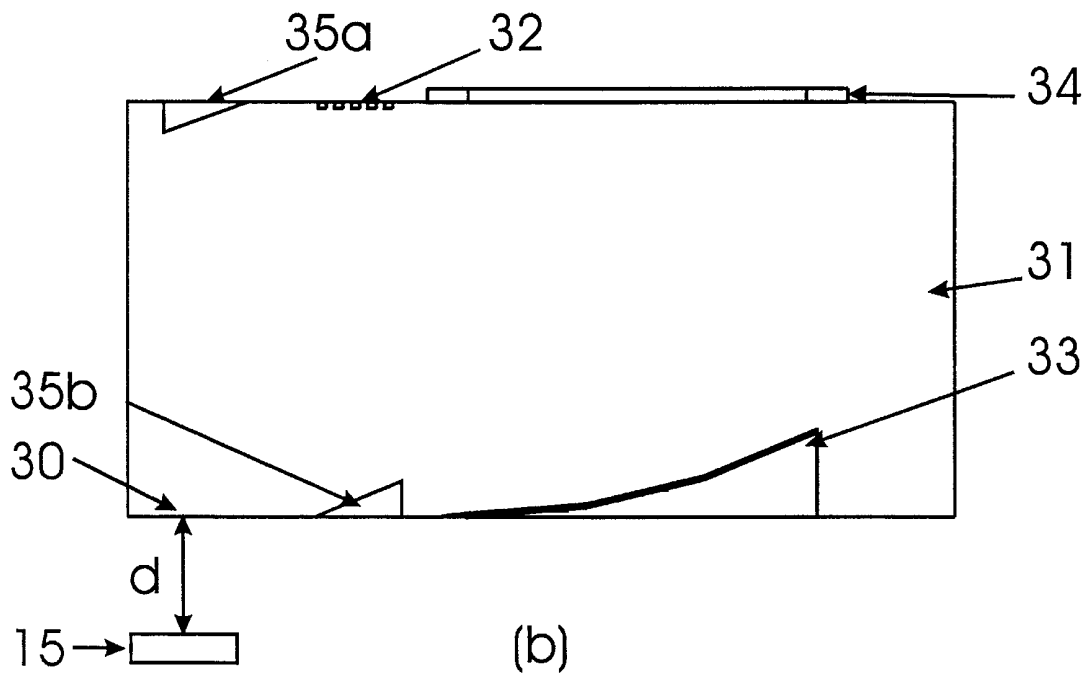

Figure 4



(a)



(b)

Figure 5

5/12

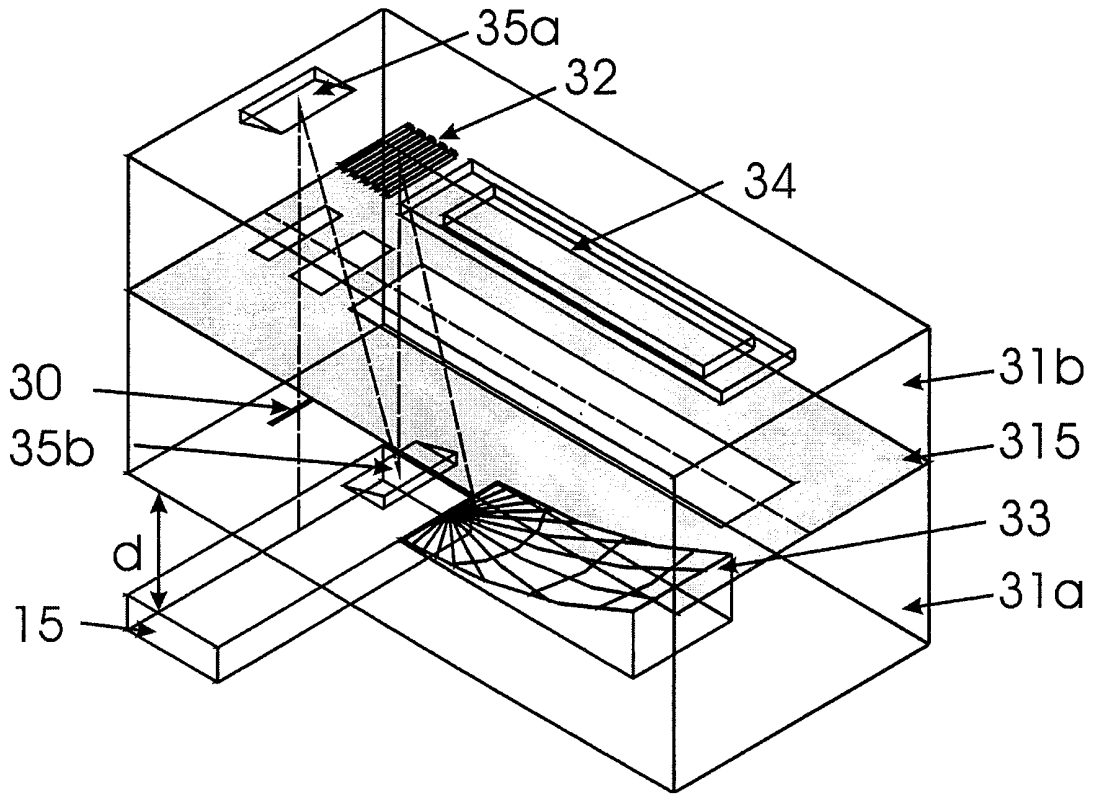

Figure 6

6/12

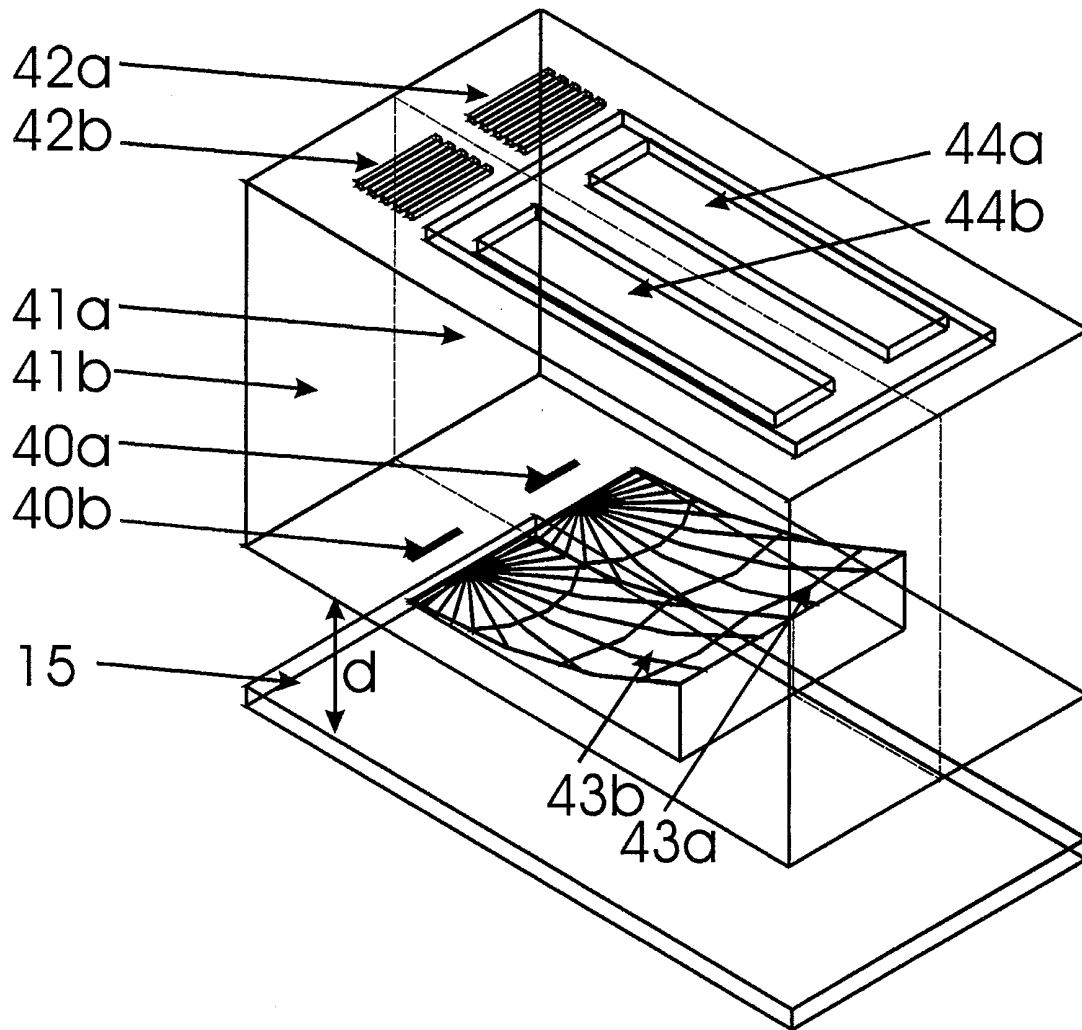

Figure 7

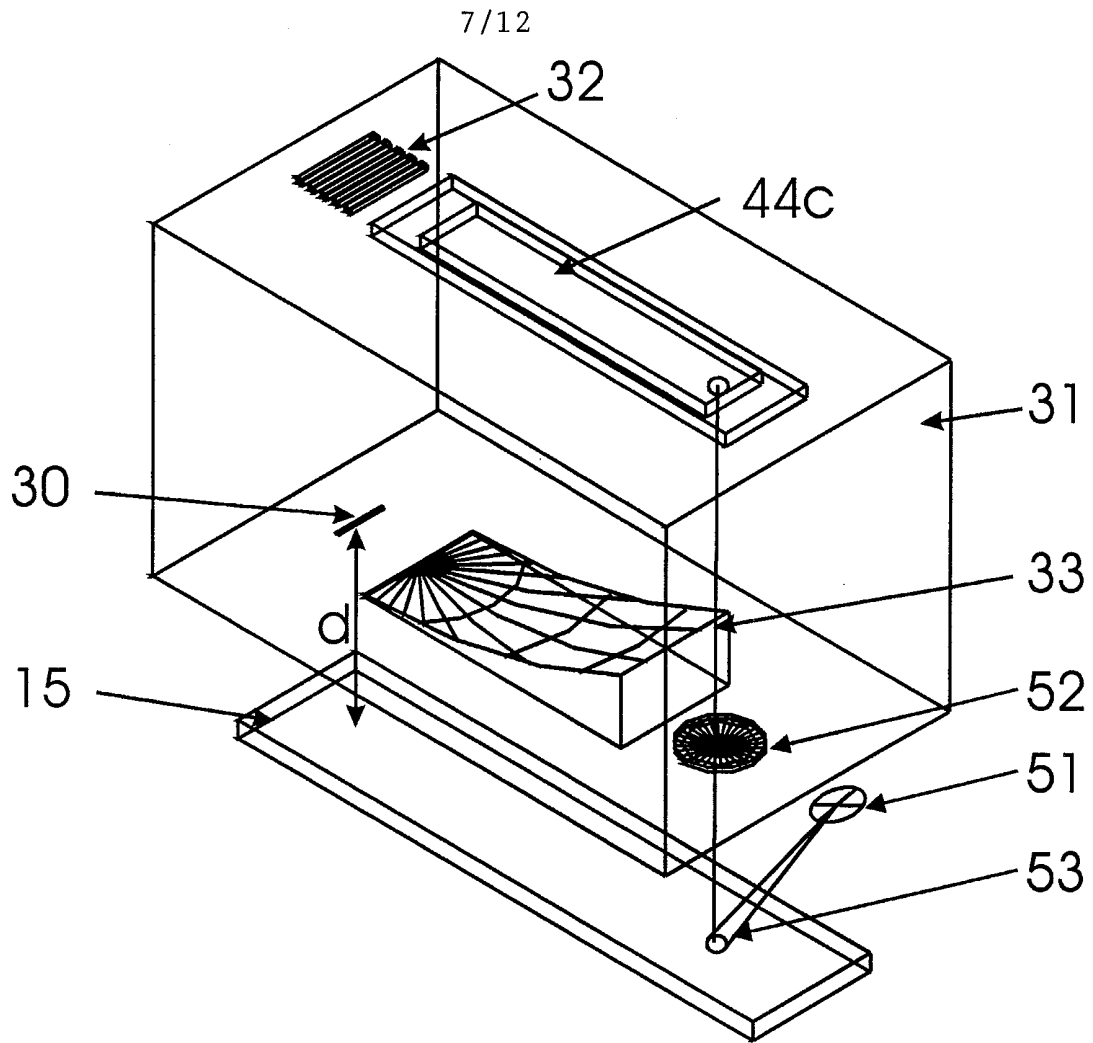

Figure 8

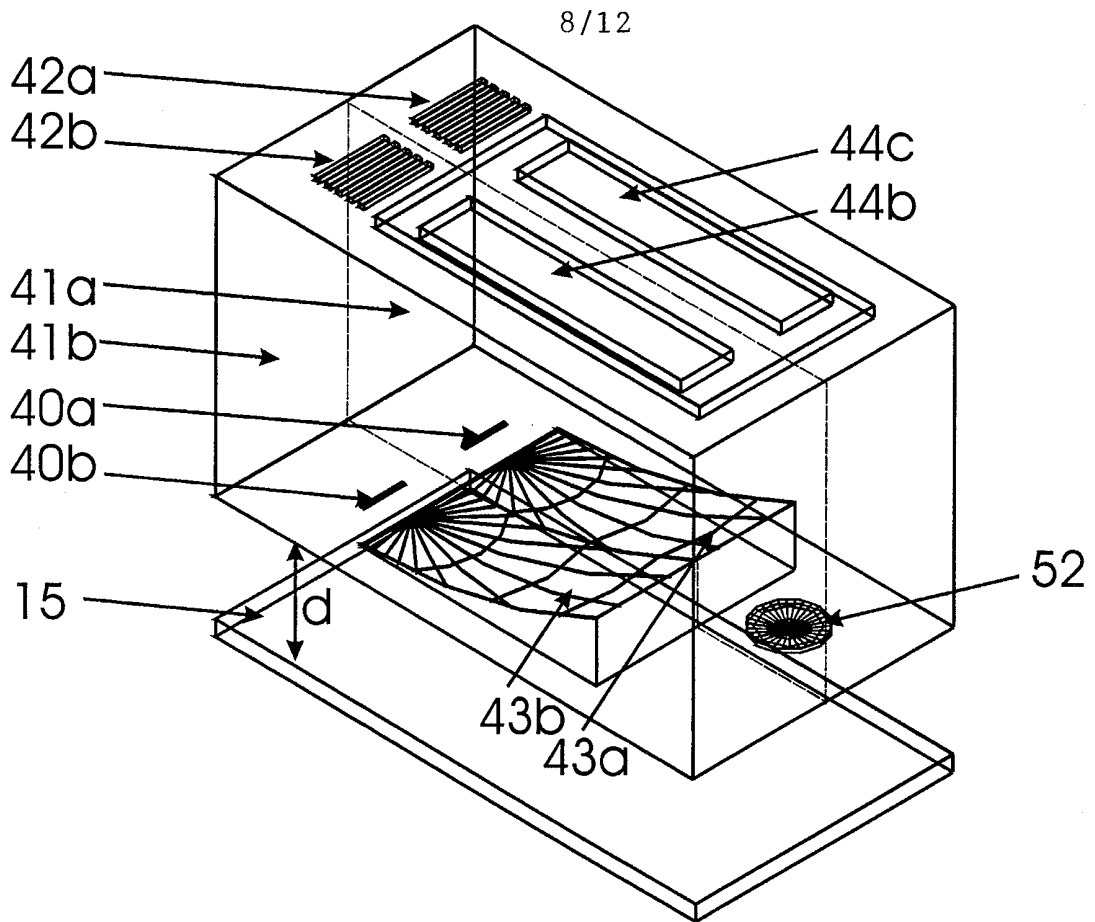

Figure 9

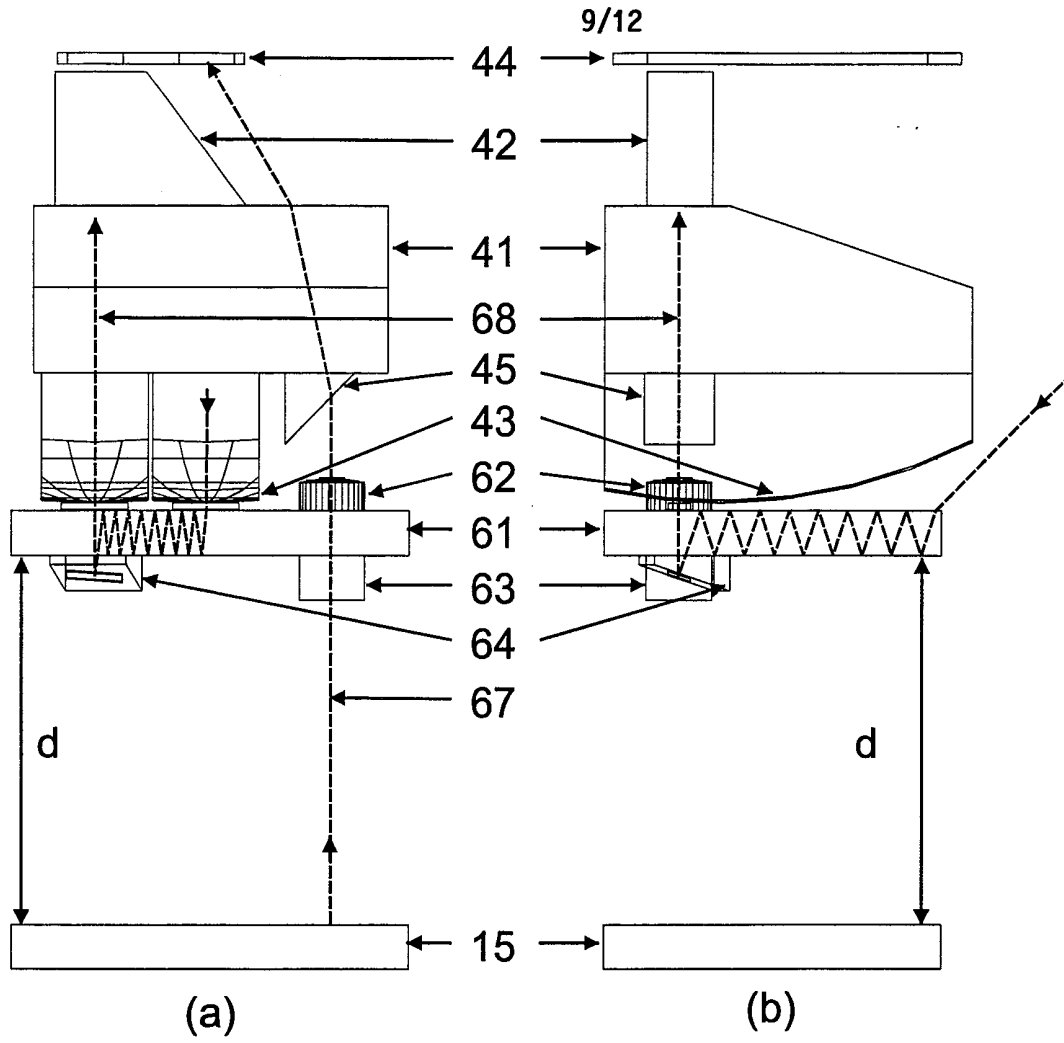

Figure 10

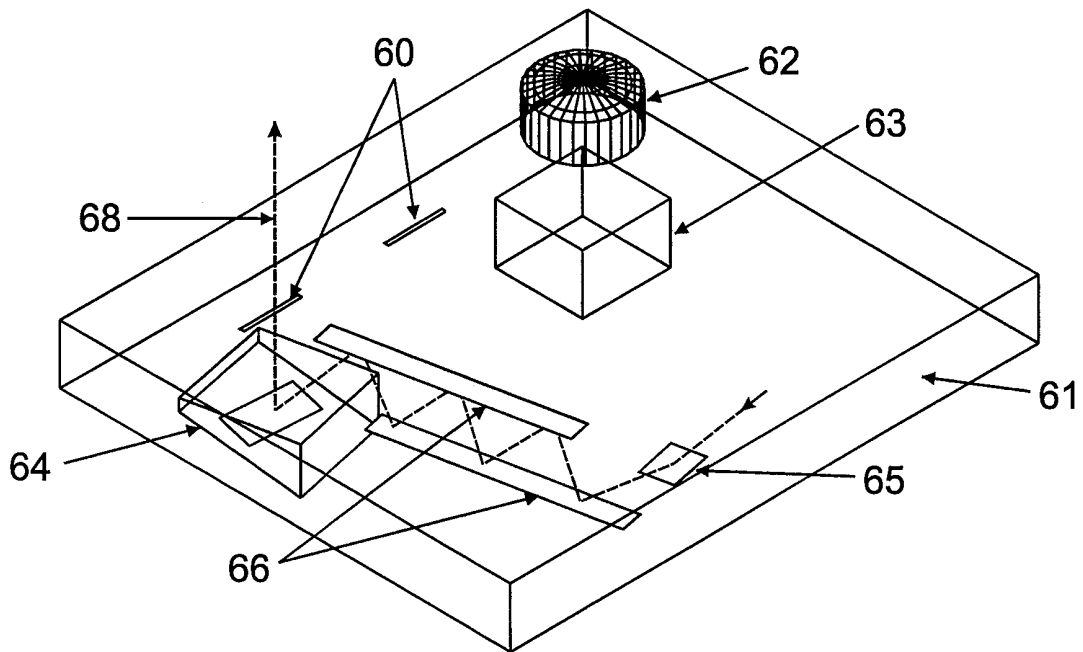

Figure 11

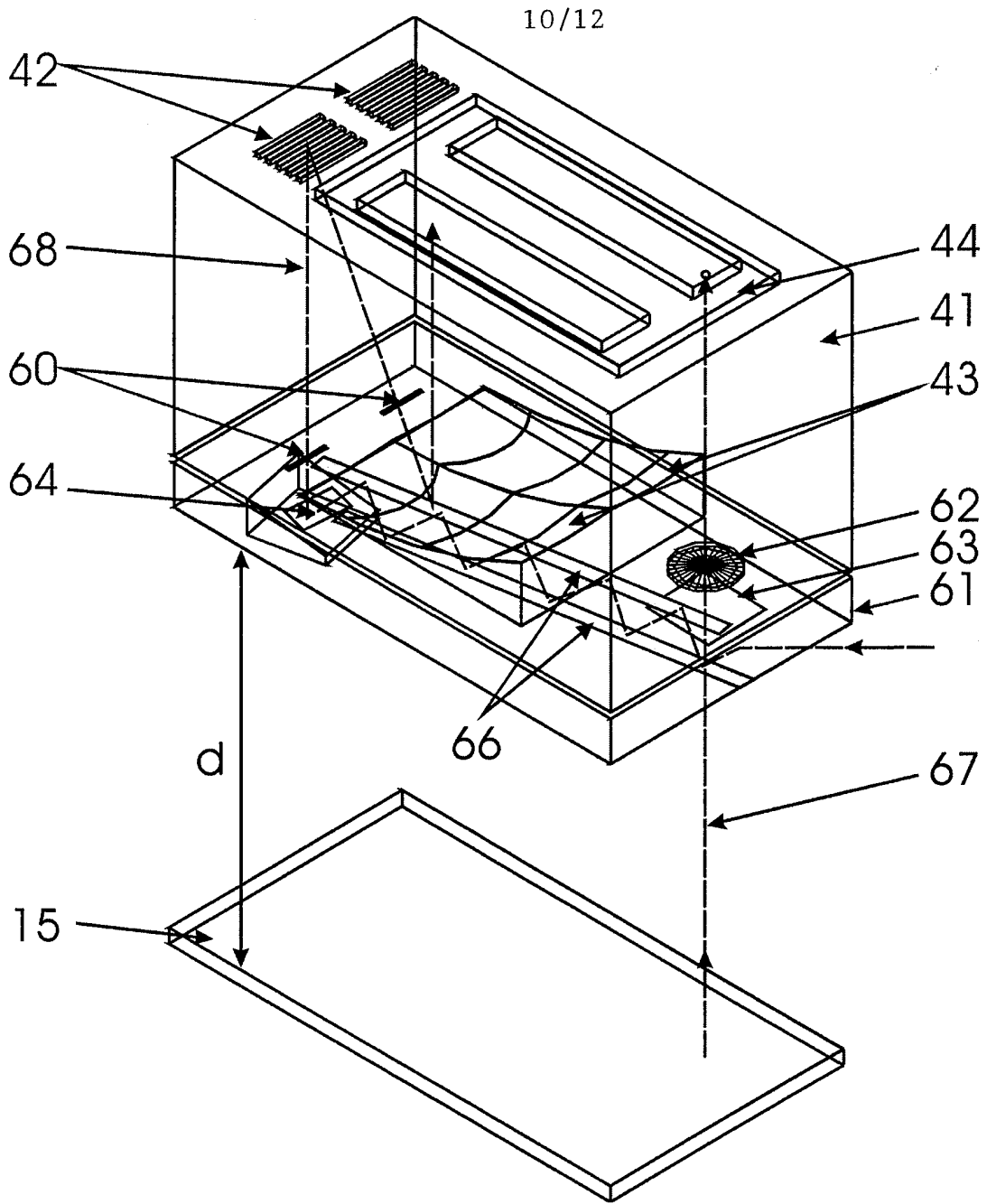

Figure 12

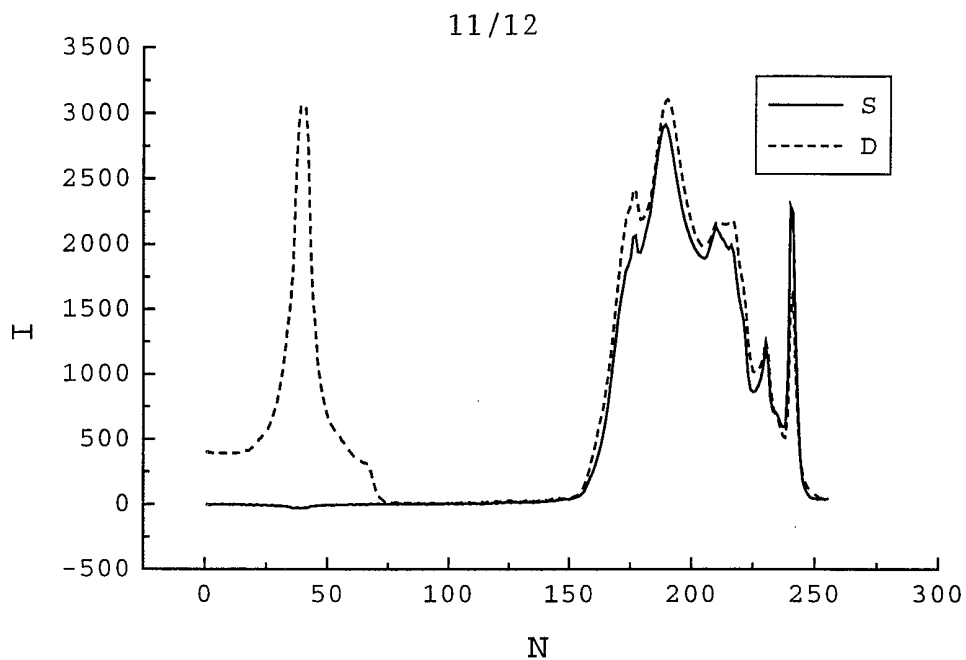

Figure 13

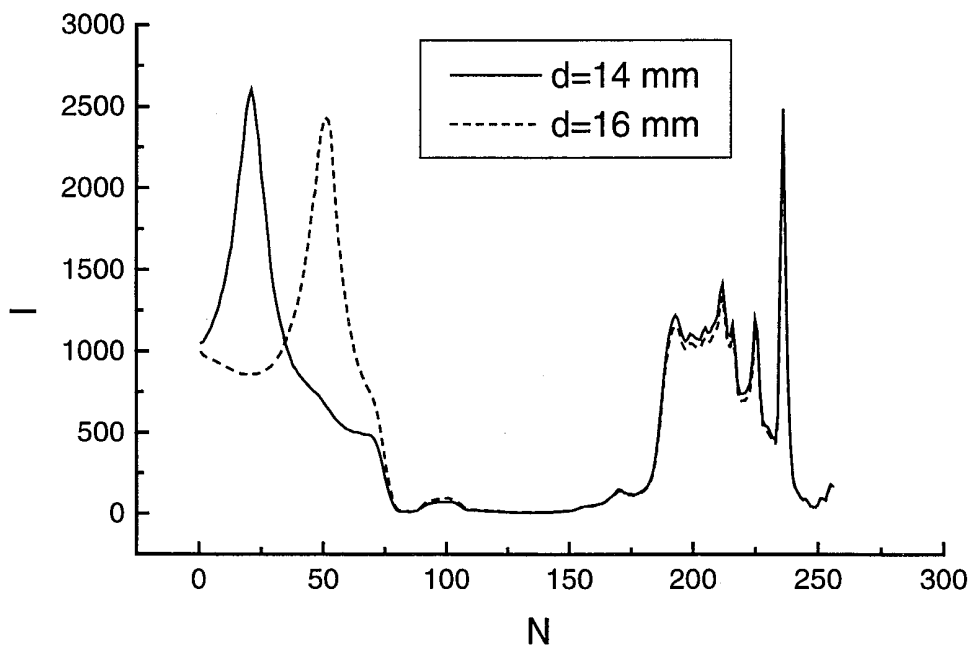

Figure 14

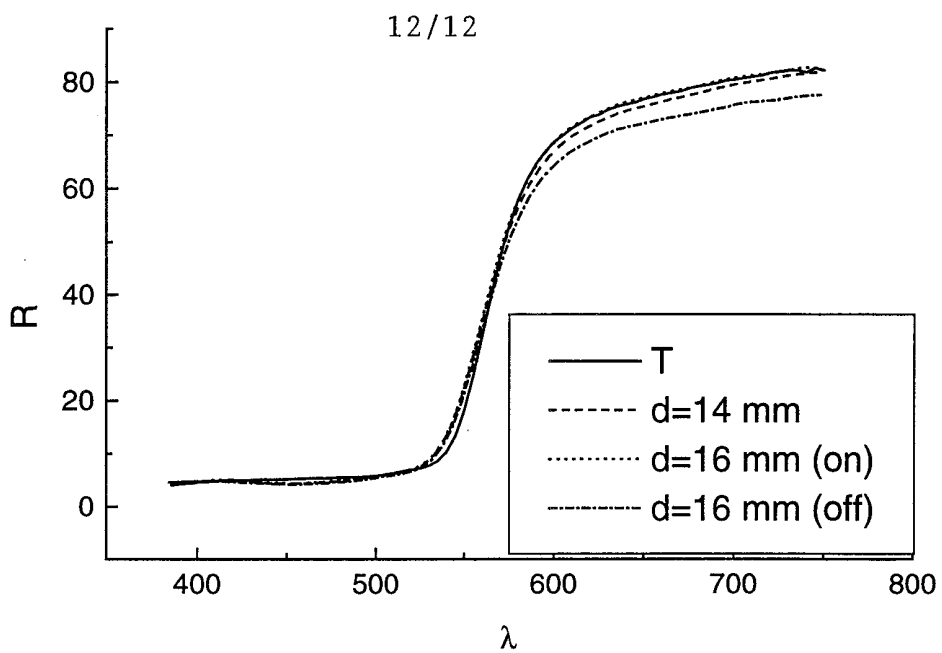

Figure 15

INTERNATIONAL SEARCH REPORT

International Application No

PCT/DK 00/00006

A. CLASSIFICATION OF SUBJECT MATTER
 IPC 7 G01J3/18 G01J3/28 G01J3/02

According to International Patent Classification (IPC) or to both national classification and IPC

B. FIELDS SEARCHED

Minimum documentation searched (classification system followed by classification symbols)

IPC 7 G01J G01B G01S

Documentation searched other than minimum documentation to the extent that such documents are included in the fields searched

Electronic data base consulted during the international search (name of data base and, where practical, search terms used)

C. DOCUMENTS CONSIDERED TO BE RELEVANT

Category *	Citation of document, with indication, where appropriate, of the relevant passages	Relevant to claim No.
Y	WO 96 05487 A (RIDYARD ANDREW ; SHREWSBURY DAVID (GB)) 22 February 1996 (1996-02-22) cited in the application	1-3, 8, 9, 11, 14, 17-20, 23, 24, 26, 27, 29, 31, 32, 41, 42, 46-48
A	page 1, line 12 - line 15 page 3, line 9 - line 21 page 5, line 12 - page 6, line 14 page 7, line 30 - page 9, line 3 page 9, line 21 - line 29 figure 1 --- -/--	15, 16, 21, 22

Further documents are listed in the continuation of box C.

Patent family members are listed in annex.

* Special categories of cited documents :

- "A" document defining the general state of the art which is not considered to be of particular relevance
- "E" earlier document but published on or after the international filing date
- "L" document which may throw doubts on priority claim(s) or which is cited to establish the publication date of another citation or other special reason (as specified)
- "O" document referring to an oral disclosure, use, exhibition or other means
- "P" document published prior to the international filing date but later than the priority date claimed

- "T" later document published after the international filing date or priority date and not in conflict with the application but cited to understand the principle or theory underlying the invention
- "X" document of particular relevance; the claimed invention cannot be considered novel or cannot be considered to involve an inventive step when the document is taken alone
- "Y" document of particular relevance; the claimed invention cannot be considered to involve an inventive step when the document is combined with one or more other such documents, such combination being obvious to a person skilled in the art.
- "&" document member of the same patent family

Date of the actual completion of the international search

24 March 2000

Date of mailing of the international search report

05/04/2000

Name and mailing address of the ISA

European Patent Office, P.B. 5818 Patentlaan 2
 NL - 2280 HV Rijswijk
 Tel. (+31-70) 340-2040, Tx. 31 651 epo nl,
 Fax: (+31-70) 340-3016

Authorized officer

Jacquin, J

INTERNATIONAL SEARCH REPORT

International Application No

PCT/DK 00/00006

C.(Continuation) DOCUMENTS CONSIDERED TO BE RELEVANT		
Category	Citation of document, with indication, where appropriate, of the relevant passages	Relevant to claim No.
Y A	WO 97 02475 A (LOCKHEED MARTIN ENERGY SYS INC) 23 January 1997 (1997-01-23) cited in the application page 4, line 16 -page 5, line 27 figure 3	1-3,8,9, 11,14, 17-20 4,15,16
A	EP 0 489 286 A (ZEISS CARL FA ;ZEISS STIFTUNG (DE)) 10 June 1992 (1992-06-10) cited in the application column 1, line 38 - line 44 column 2, line 13 - line 21	5,12,13
A	PATENT ABSTRACTS OF JAPAN vol. 004, no. 138 (P-029), 27 September 1980 (1980-09-27) & JP 55 087925 A (HASUMI RITSUO), 3 July 1980 (1980-07-03) abstract	6,7
A	US 3 973 850 A (POUEY MICHEL) 10 August 1976 (1976-08-10) column 5, line 23 column 13, line 25 - line 39	10
Y A	US 5 493 393 A (BERANEK MARK W ET AL) 20 February 1996 (1996-02-20) cited in the application column 2, line 4 - line 18 column 8, line 23 - line 51 column 9, line 19 - line 58	23,24,41 29-31, 42,44-46
Y A	US 4 770 530 A (VAN AKEN HAROLD ET AL) 13 September 1988 (1988-09-13) cited in the application column 3, line 20 - line 34 column 3, line 48 - line 61 column 6, line 7 - line 51 column 10, line 13 - line 35 column 10, line 56 -column 11, line 19 figures 1,4,6,7	26,27, 29,31, 32,42, 46-48 30, 43-45, 49,50
A	US 4 825 091 A (BREYER KARL-HERMANN ET AL) 25 April 1989 (1989-04-25) column 2, line 56 -column 3, line 2 figure 1	33-39, 43-45,49
A	US 4 585 349 A (GROSS DANIEL ET AL) 29 April 1986 (1986-04-29) column 3, line 33 - line 68 figure 1	26-50

INTERNATIONAL SEARCH REPORT

Information on patent family members

International Application No

PCT/DK 00/00006

Patent document cited in search report		Publication date	Patent family member(s)	Publication date
WO 9605487	A	22-02-1996	AT 188290	T 15-01-2000
			AU 685998	B 29-01-1998
			AU 3227095	A 07-03-1996
			CA 2197340	A 22-02-1996
			DE 69514237	D 03-02-2000
			EP 0775297	A 28-05-1997
			JP 10504104	T 14-04-1998
			NZ 291207	A 28-07-1998
			US 5812262	A 22-09-1998
			ZA 9506700	A 10-04-1996
WO 9702475	A	23-01-1997	AU 5436696	A 05-02-1997
			US 5754290	A 19-05-1998
EP 0489286	A	10-06-1992	DE 4038638	A 11-06-1992
			AT 126586	T 15-09-1995
			DE 59106269	D 21-09-1995
			JP 4294223	A 19-10-1992
			US 5159404	A 27-10-1992
JP 55087925	A	03-07-1980	NONE	
US 3973850	A	10-08-1976	FR 2180574	A 30-11-1973
			DE 2238662	A 25-10-1973
			JP 1131788	C 27-01-1983
			JP 49022151	A 27-02-1974
			JP 54033146	B 18-10-1979
			US 4036558	A 19-07-1977
US 5493393	A	20-02-1996	US 4999489	A 12-03-1991
			CA 2098832	A 22-06-1992
			EP 0563314	A 06-10-1993
			WO 9211517	A 09-07-1992
US 4770530	A	13-09-1988	CA 1319531	A 29-06-1993
			DE 3713149	A 29-10-1987
			DE 3788670	D 17-02-1994
			DE 3788670	T 21-07-1994
			EP 0242725	A 28-10-1987
			GB 2189623	A, B 28-10-1987
US 4825091	A	25-04-1989	DE 3703422	A 18-08-1988
			EP 0277542	A 10-08-1988
			JP 63195514	A 12-08-1988
US 4585349	A	29-04-1986	CH 663466	A 15-12-1987
			EP 0142464	A 22-05-1985
			JP 60073405	A 25-04-1985