

**(12) STANDARD PATENT**  
**(19) AUSTRALIAN PATENT OFFICE**

(11) Application No. **AU 2018317375 B2**

(54) Title  
**Stackable fractional plastic pallet**

(51) International Patent Classification(s)  
**A47B 7/02** (2006.01)                      **B65D 19/40** (2006.01)  
**B65D 19/00** (2006.01)

(21) Application No: **2018317375**                      (22) Date of Filing: **2018.08.14**

(87) WIPO No: **WO19/036422**

(30) Priority Data

(31) Number	(32) Date	(33) Country
<b>16/100,387</b>	<b>2018.08.10</b>	<b>US</b>
<b>62/641,507</b>	<b>2018.03.12</b>	<b>US</b>
<b>62/546,217</b>	<b>2017.08.16</b>	<b>US</b>

(43) Publication Date: **2019.02.21**

(44) Accepted Journal Date: **2021.05.13**

(71) Applicant(s)  
**CHEP Technology Pty Limited**

(72) Inventor(s)  
**WOOD, Matthew;BARNSWELL, Paul;DAUBENSPECK, Bradley Wayne;NORMAN, Craig Rolland**

(74) Agent / Attorney  
**Spruson & Ferguson, GPO Box 3898, Sydney, NSW, 2001, AU**

(56) Related Art  
**US 2010/0154685 A1**  
**US 2013/0119624 A1**  
**US 6895868 B1**  
**US 2015/0135999 A1**  
**US 4735154 A**  
**US 2006/0272556 A1**



- (51) International Patent Classification:  
*A47B 7/02* (2006.01)      *B65D 19/00* (2006.01)  
*B65D 19/40* (2006.01)
- (21) International Application Number:  
PCT/US2018/046625
- (22) International Filing Date:  
14 August 2018 (14.08.2018)
- (25) Filing Language: English
- (26) Publication Language: English
- (30) Priority Data:  
62/546,217      16 August 2017 (16.08.2017)      US  
62/641,507      12 March 2018 (12.03.2018)      US  
16/100,387      10 August 2018 (10.08.2018)      US
- (71) Applicant: **CHEP TECHNOLOGY PTY LIMITED**  
[AU/AU]; Level 10, Angel Place, 123 Pitt Street, Sydney,  
New South Wales 2000 (AU).
- (72) Inventors; and  
(71) Applicants (*for US only*): **WOOD, Matthew** [US/US];  
213 Granada Blvd, Davenport, Florida 33837 (US).  
**BARNSWELL, Paul** [US/US]; 102 Via Rosa Court, De-  
bary, Florida 32713 (US). **DAUBENSPECK, Bradley**  
**Wayne** [US/US]; 5825 Caymus Loop, Windermere, Flori-  
da 34786 (US). **NORMAN, Craig Rolland** [US/US]; 1015  
Garden Crossing Lane, Cumming, Georgia 30040 (US).
- (74) Agent: **TAYLOR, Michael W.** et al.; Allen, Dyer, Doppelt  
& Gilchrist, P.A., 255 S. Orange Avenue, Suite 1401, Or-  
lando, Florida 32801 (US).
- (81) Designated States (*unless otherwise indicated, for every  
kind of national protection available*): AE, AG, AL, AM,  
AO, AT, AU, AZ, BA, BB, BG, BH, BN, BR, BW, BY, BZ,  
CA, CH, CL, CN, CO, CR, CU, CZ, DE, DJ, DK, DM, DO,  
DZ, EC, EE, EG, ES, FI, GB, GD, GE, GH, GM, GT, HN,  
HR, HU, ID, IL, IN, IR, IS, JO, JP, KE, KG, KH, KN, KP,  
KR, KW, KZ, LA, LC, LK, LR, LS, LU, LY, MA, MD, ME,  
MG, MK, MN, MW, MX, MY, MZ, NA, NG, NI, NO, NZ,

(54) Title: STACKABLE FRACTIONAL PLASTIC PALLET

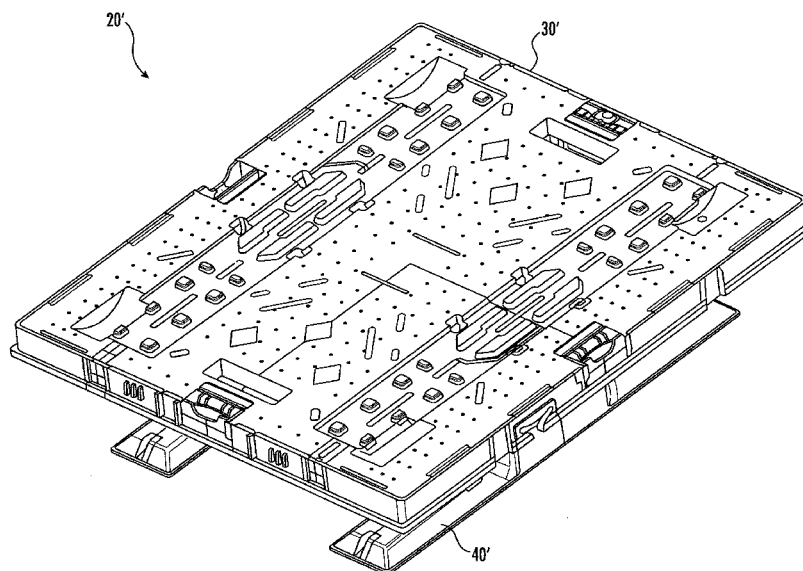

FIG. 11

(57) Abstract: A pallet includes a top deck that includes a product support surface and an opposing underside, and with the product support surface including a pair of pallet support leg receiving areas. A pair of pallet support legs is on the underside of the top deck and aligned with the pallet support leg receiving areas. Each pallet support leg including a center leg section having a first end adjacent the underside of the top deck and a second end opposite the first end, and a pair of leg extensions extending outwards from the second end of the center leg section. An underside of the center leg section and the pair of leg extensions are configured to engage one of the pallet support leg receiving areas of an identical pallet when stacked thereon.



OM, PA, PE, PG, PH, PL, PT, QA, RO, RS, RU, RW, SA,  
SC, SD, SE, SG, SK, SL, SM, ST, SV, SY, TH, TJ, TM, TN,  
TR, TT, TZ, UA, UG, US, UZ, VC, VN, ZA, ZM, ZW.

**(84) Designated States** (*unless otherwise indicated, for every kind of regional protection available*): ARIPO (BW, GH, GM, KE, LR, LS, MW, MZ, NA, RW, SD, SL, ST, SZ, TZ, UG, ZM, ZW), Eurasian (AM, AZ, BY, KG, KZ, RU, TJ, TM), European (AL, AT, BE, BG, CH, CY, CZ, DE, DK, EE, ES, FI, FR, GB, GR, HR, HU, IE, IS, IT, LT, LU, LV, MC, MK, MT, NL, NO, PL, PT, RO, RS, SE, SI, SK, SM, TR), OAPI (BF, BJ, CF, CG, CI, CM, GA, GN, GQ, GW, KM, ML, MR, NE, SN, TD, TG).

**Published:**

— *with international search report (Art. 21(3))*

## STACKABLE FRACTIONAL PLASTIC PALLET

### Technical Field

[0001] The present disclosure relates to the field of pallets, and more particularly, to a fractional plastic pallet that is stackable with other fractional plastic pallets.

### Background

[0002] Retail stores often prefer the use of fractional pallets when displaying products thereon that are for customer purchase. A fractional pallet is typically one-quarter to one-half the size of a full size pallet. Fractional pallets have a significantly smaller footprint than full size pallets, which allows the retail stores to display a greater variety of products within the same size area as a conventional pallet.

[0003] In addition, retail stores often prefer the use of fractional plastic pallets instead of fractional wood pallets. Fractional plastic pallets are more aesthetically pleasing than fractional wood pallets, as well as being more sanitary.

[0004] Even in view of current fractional plastic pallets, there is still a need for a fractional plastic pallet that can be easily moved by pallet handling equipment and can enable display use that is aesthetically acceptable. Since the products to be carried by the fractional plastic pallet at times may be relatively heavy, the load carrying capacity of the pallet should not be sacrificed while also providing accessibility.

### Summary

[0004a] In a first aspect, the present invention provides a pallet comprising:

a top deck including a product support surface

and an opposing underside, and with the product support surface including a pair of pallet support leg receiving areas; and

a pair of pallet support legs on the underside of said top deck and aligned with the pallet support leg receiving areas, each pallet support leg including:

a center leg section having a first end adjacent the underside of said top deck, and a second end opposite the first end, with the center leg section spaced from all sides of said top deck to allow four way entry with pallet handling equipment,

a pair of leg extensions extending outwards from the second end of the center leg section, with each leg extension forming a gap

1a

between the underside of said top deck to allow entry with the pallet handling equipment, and

with an underside of the center leg section and the pair of leg extensions configured to engage one of the pallet support leg receiving areas of an identical pallet when stacked thereon.

**[0004b]** In a second aspect, the present invention provides a method for making a pallet comprising:

forming a top deck including a pallet support surface and an opposing underside, and with the product support surface including a pair of pallet support leg receiving areas;

forming a pair of pallet support legs, with each pallet support leg including:

a center leg section having a first end and a second end opposite the first end, with the center leg section spaced from all sides of said top deck to allow four way entry with pallet handling equipment,

a pair of leg extensions extending outwards from the second end of the center leg section, with each leg extension forming a gap between the underside of said top deck to allow entry with the pallet handling equipment, and

with an underside of the center leg section and the pair of leg extensions configured to engage one of the pallet support leg receiving areas of an identical pallet when stacked thereon; and

coupling the first ends of the center leg sections of the pair of pallet support legs to the underside of the top deck, with the pair of pallet support legs being aligned with the pallet support leg receiving areas in the top deck.

**[0005]** A pallet includes a top deck that including a product support surface and an opposing underside, and with the product support surface including a pair of pallet support leg receiving areas. A pair of pallet support legs is on the underside of the top deck and is aligned with the pallet support leg receiving areas.

**[0006]** Each pallet support leg includes a center leg section and a pair of leg extensions. The center leg section has a first end adjacent the underside of the top deck, and a second end opposite the first end. The pair of leg extensions extend

outwards from the second end of the center leg section. An underside of the center leg section and the pair of leg extensions are configured to engage one of the pallet support leg receiving areas of an identical pallet when stacked thereon.

**[0007]** Each pallet support leg receiving area is recessed from the product support surface. The pair of pallet support legs is configured to removably couple to the underside of the top deck.

**[0008]** An underside of the pair of pallet support legs is configured to interlock with the pair of pallet support leg receiving areas of the identical pallet when stacked thereon. Each pallet support leg receiving area includes a pattern of spaced apart protrusions matching a corresponding pattern of spaced apart protrusion openings in the underside of each pallet support leg.

**[0009]** The underside of the top deck includes a pair of center leg section openings, with each center leg section opening to receive the first end of one of the center leg sections. Each center leg section opening is separated by a divider, and wherein the first end of each center leg section is slotted to receive the divider. Each center leg section includes a plurality of locking tabs for engaging a plurality of locking tab openings within each center leg section opening.

**[0010]** Each pallet support leg has a length within a range of 75% to 95% of a length of the top deck, and a width within a range of 10% to 20% of a width of the top deck. A length of each center leg section is within a range of 30% to 40% of an overall length of each pallet support leg. In one embodiment, the top deck has a length of 24 inches and a width of 20 inches.

**[0011]** Another aspect is directed to a method for making a pallet as described above.

### **Brief Description of the Drawings**

**[0012]** FIG. 1 is an upper perspective view of a fractional plastic pallet in accordance with the disclosure.

**[0013]** FIG. 2 is a top view of the fractional plastic pallet shown in FIG. 1.

**[0014]** FIG. 3 is a bottom view of the fractional plastic pallet shown in FIG. 1.

**[0015]** FIG. 4 is a side view of the fractional plastic pallet shown in FIG. 1.

**[0016]** FIG. 5 is an end view of the fractional plastic pallet shown in FIG. 1.

**[0017]** FIG. 6 is a top perspective view of one of the product display

attachment points shown in FIG. 1.

**[0018]** FIGS. 7 and 8 are perspective views of a pallet jack in position at different entry points on the fractional plastic pallet shown in FIG. 1.

**[0019]** FIG. 9 is a perspective view of the fractional plastic pallet shown in FIG. 1 stacked with another fractional plastic pallet.

**[0020]** FIG. 10 is an upper perspective view of a reconfigurable pallet/dolly platform in accordance with the disclosure.

**[0021]** FIG. 11 is a top perspective view of the reconfigurable pallet/dolly platform shown in FIG. 10 configured as a pallet.

**[0022]** FIG. 12 is a bottom perspective view of the reconfigurable pallet/dolly platform shown in FIG. 10 configured as a pallet.

**[0023]** FIG. 13 is a top perspective view of the reconfigurable pallet/dolly platform shown in FIG. 10 configured as a dolly.

**[0024]** FIG. 14 is a bottom perspective view of the reconfigurable pallet/dolly platform shown in FIG. 10 configured as a dolly.

**[0025]** FIG. 15 is a bottom view of the reconfigurable pallet/dolly platform shown in FIG. 10.

**[0026]** FIG. 16 is top view of the reconfigurable pallet/dolly platform shown in FIG. 10.

**[0027]** FIG. 17 is a perspective view of one of the pallet support legs as shown in FIGS. 11-12.

**[0028]** FIG. 18 is a bottom perspective view of the reconfigurable pallet/dolly platform shown in FIG. 10.

**[0029]** FIG. 19 is a side view of the pallet shown in FIGS. 11-12 stacked with another pallet.

**[0030]** FIG. 20 is a side view of the dolly shown in FIGS. 13-14 stacked with another dolly.

### **Detailed Description**

**[0031]** The present description is made with reference to the accompanying drawings, in which exemplary embodiments are shown. However, many different embodiments may be used, and thus the description should not be construed as limited to the particular embodiments set forth herein. Rather, these embodiments

are provided so that this disclosure will be thorough and complete. Like numbers refer to like elements throughout, and prime notations are used to indicate similar elements in alternative embodiments.

**[0032]** Referring initially to FIGS. 1-5, the illustrated fractional plastic pallet **20** includes a top deck **30**, and a pair of pallet support legs **40** coupled to the top deck. The pallet support legs **40** are configured to enable 4-way entry by pallet handling equipment, such as a forklift or a pallet jack. As will be discussed in detail below, the fractional plastic pallet **20** is also reparable, stackable and includes a number of different product display attachment points.

**[0033]** The illustrated fractional plastic pallet **20** is also known as a quarter pallet since it is one quarter the size of a conventional full size pallet. A size of the fractional plastic pallet **20** is 24 inches by 20 inches. As readily appreciated by those skilled in the art, the dimensions of the pallet **20** may be changed to accommodate other fractional sizes, such as half-size, for example. Also, plastic used in the fractional plastic pallet **20** may be recyclable.

**[0034]** The top deck **30** includes a product support surface **32** and an opposing underside **34**, and with outer exposed sides extending between the product support surface and the opposing underside. The outer exposed sides include spaced apart sides **36** and spaced apart sides **38**. Sides **36** are parallel to the pallet support legs **40**, and sides **38** are orthogonal to the pallet support legs **40**.

**[0035]** The top deck **30** includes a number of different product display attachment points for securing a product display or box to the fractional plastic pallet **20**. When the fractional plastic pallet **20** is on the floor within a store with products thereon, for example, a product display helps to promote the products. U.S. patent no. 9,387,953 discloses a fractional plastic pallet with product display attachment points, and is incorporated herein by reference in its entirety. The '953 patent is assigned to the current assignee of the present invention.

**[0036]** Product display attachment points include display attachment slots **50**, **52** and **54** in the product support surface **32**, as shown in FIG. 2. Each display attachment slot **50**, **52**, **54** is rectangular shaped and is sized to receive a tab descending from the base of a product display so as to allow the product display to be held in place on the fractional plastic pallet **20**. The display attachment slots **50**, **52**, **54** extend through the product support surface **32** and are visible from the

opposing underside **34**, as shown in FIG. 3.

**[0037]** Display attachment slots **50** are located adjacent the edges of the top deck **30**, display attachment slots **52** are located near the center of the top deck **30**, and display attachment points **54** are also located adjacent the edges of the top deck **30**. Display attachment slots **52** may be provided to cooperate with display attachment slots **50**. Display attachment slots **54** are provided to accommodate a different size product display to be held in place on the fractional plastic pallet **20**.

**[0038]** Four display attachment slots **50** are adjacent each side **36**, and two display attachment slots **50** are adjacent each side **38**. In the center of the fractional plastic pallet **20** there are two display attachment slots **52**. The two display attachment slots **52** are separated by a hand access hole **60**. There is one display attachment slot **54** centered on each of the sides **36**, **38** of the top deck **30**.

**[0039]** Product display attachment points further include display attachment slots **70**. Each display attachment slot **70** is adjacent the edges **36**, **38** of the top deck **30**, and centered between the corners of the fractional plastic pallet **20**.

**[0040]** Referring now to FIG. 6, each display attachment slot **70** includes an outer slot **72** within the top deck **30** and an inner slot **82** recessed within the outer slot. The outer slot **72** includes sides **74** and a partially closed bottom **76** forming a curved shelf. The inner slot **82** is adjacent the curved shelf **76** and is recessed below the outer slot **72**. The inner slot **82** has a pair of spaced apart sidewalls **84** and **86**, and a closed bottom **88**.

**[0041]** Within the inner slot **82**, sidewall **84** includes a projection **90** extending therefrom, and the opposing sidewall **86** includes a tapered member **92** extending therefrom. The tapered member **92** has a downwards taper towards the projection **90**. If the product display tab has an appropriately positioned hole, that hole can engage and lock onto the projection **90** or the tapered member **92**.

**[0042]** The sidewall **86** with the tapered member **92** is curved corresponding to the curved shelf **76**, whereas the sidewall **84** with the projection **90** is not curved. The tapered member **92** includes a lowermost surface **94** that is perpendicular to the closed bottom **88** of the inner slot **82**. There is a gap between the flat underside **94** and the closed bottom **88**.

**[0043]** The projection **90** has a quarter-spherical shape, for example. The tapered member **92** is aligned with a center of the projection **90**.

**[0044]** Product display attachment points further include display attachment slots **100**. Each display attachment slot **100** is adjacent a respective display attachment slot **70**, and is recessed from a side **36, 38** of the top deck **30**.

**[0045]** A significant portion of the corresponding sides **36, 38** of the top deck **30** is removed so as to expose the display attachment slot **100**. Removal of the corresponding sides **36, 38** is not uniform for the display attachment slots **100** so as to form a pair of spaced apart retention tabs **102** for securing a product display tab. The retention tabs **102** are at an upper portion of the display attachment slot **100**, while the lower portion of the display attachment slot **100** is fully exposed.

**[0046]** Product display attachment points include display attachment slots **110**, which are also recessed from the sides **38** of the top deck **30**. However, the side **38** of the top deck **30** is removed so as to fully expose the display attachment slot **110**. To hold a product display tab in place, the display attachment slot **110** includes one or more engagement teeth **112**. Each engagement tooth **112** has a tapered side projecting outwards and a flat bottom.

**[0047]** In the illustrated embodiment, there are three engagement teeth **112** for each display attachment slot **110**. There are two display attachment slots **110** for each side **38**. There may be a different number of engagement teeth **112** in other embodiments of the display attachment slots **110**.

**[0048]** Product display attachment points further include display attachment slots **118**. The display attachment slots **118** are diamond shaped. There are three display attachment slots **118** on each side of the hand access hole **60**. The respective display attachment slots **118** are grouped together in a triangular pattern.

**[0049]** As noted above, the fractional plastic pallet **20** is repairable. The pallet support legs **40** are formed separate from the top deck **30**, with the top deck **30** being detachable from the pallet support legs **40** for pallet repair. Snap pins, for example, may be used to secure each pallet support leg **40** to an underside of the top deck **30**. Alternatively, attachments other than snap pins may be used, as readily appreciated by those skilled in the art. If the fractional plastic pallet **20** is damaged, anyone of the pallet support legs **40** and the top deck **30** may be replaced as needed.

**[0050]** Each pallet support leg **40** has a center leg section **42** and a pair of leg extensions **44** extending from the center leg section **42**. The center leg section **42**

and the pair of leg extensions **44** are monolithically formed. The center leg section **42** is secured to the top deck **30** while the leg extensions **44** provide pallet stability.

**[0051]** Each center leg section **42** is spaced from the sides **36, 38** of the top deck **30**. This advantageously allows four way entry with pallet handling equipment **150**, as illustrated in FIGS. 7 and 8. The illustrated pallet jack **150**, for example, may be used to lift the fractional plastic pallet **20** from any of the four sides of the pallet. The pallet support legs **40** are sized and positioned on the underside **34** of the top deck **30** so that tines **152** with a spacing of 21 inches or 27 inches is supported.

**[0052]** Each pallet support leg **40** has a length within a range of 75% to 95% of the length of the top deck **30**, and a width within a range of 10% to 20% of a width of the top deck **30**. The overall length and width of the pallet support legs **40** provide stability for the pallet **20**. Also, a length of each center leg section is within a range of 30% to 40% of an overall length of each pallet support leg **40**.

**[0053]** As noted above, the fractional plastic pallet **20** may be sized such that the top deck **30** has a length of 24 inches and a width of 20 inches. An example length of the pallet support legs **40** may be 20.4 inches and an example width of each pallet support leg **40** may be 2.95 inches. An example length of the center leg section **42** may be 5.28 inches.

**[0054]** In addition, the fractional plastic pallet **20** is stackable with other fractional plastic pallets **20**, as illustrated in FIG. 9. The lower surface or underside of each pallet support leg **40** is configured to engage or interlock with a pallet support leg receiving area **160** on the top deck **32** of another fractional plastic pallet **20** when stacked thereon.

**[0055]** More particularly, the pallet **20** includes a top deck **30** that includes a product support surface **32** and an opposing underside **34**, and with the product support surface **32** including a pair of pallet support leg receiving areas **160**. A pair of pallet support legs **40** is on the underside of the top deck **30** and is aligned with the pallet support leg receiving areas **160**. By having the pallet support legs **40** engaging or interlocking with the pallet support leg receiving areas **160** stability is provided as stacked fractional plastic pallets **20** are moved.

**[0056]** The illustrated pallet support leg receiving areas **160** are recessed within the product support surface **32** of the top deck **30**, as illustrated in FIG. 2. Each pallet support leg receiving area **160** is sized slight larger than the lowermost

surface **170** of a pallet support leg **40**. In addition, a grid pattern of spaced apart square protrusions **162** is provided within the pallet support leg receiving area **160**, as also shown in FIG. 2.

**[0057]** The grid pattern of spaced apart square protrusions **162** is for engaging a corresponding grid pattern of spaced apart square protrusion openings **172** on the underside **170** of each pallet support leg **40**, as shown in FIG. 3. The fractional plastic pallet **20** is not limited to the illustrated grid pattern and other configurations for engaging the underside **170** of the pallet supports legs **40** to the pallet support leg receiving areas **160** may be used, as readily appreciated by those skilled in the art.

**[0058]** Another feature of the fractional plastic pallet **20** is directed to shrink wrap gripping members **180** used with the application and retention of shrink wrap over a product being carried by the top deck **30**. Shrink wrap is commonly used to secure a product to a pallet. This is often an alternative to banding, although both can be applied if desired.

**[0059]** A problem encountered in applying shrink wrap to a pallet is in securing the ends of the shrink wrap. This problem is encountered both at the start and the finish of shrink wrapping since the wrap might not want to adhere to the product or the pallet, or may fail to retain itself against the product of the pallet at the end.

**[0060]** Referring now to FIG. 4, the illustrated shrink wrap gripping members **180** are positioned along the sides **36** of the top deck **30**. There are two shrink wrap gripping members **180** on each side **36**.

**[0061]** The shrink wrap gripping members **180** take the form of a two-sided groove, similar to the shape of an anvil. The two-sided groove has a front recess **182** and a rear recess **184** and a narrowed opening **186**. The narrowed opening **186** allows the shrink wrap to be located into the groove, but makes it harder for it to come out again. The wrap can be pulled into either the front or rear recesses **182**, **184**, and can secure an end of the wrap either at the start or at the end of the wrapping process.

**[0062]** The bottom edge of the top deck **30** includes grooves **190** for use as a banding strap locator, as illustrated in FIG. 3. Above the grooves **190** are side reinforcements **192** for additional stiffness to the sides **36**, as illustrated in FIG. 4. The side reinforcements **192** assist with supporting a load on the top deck **30** that might cause flexing of the top deck in the area above the end sections **44** of the

pallet support legs **40**.

**[0063]** The top deck **30** includes a hand access hole **60**. In the illustrated embodiment the hand access hole **60** is located at or towards the center of gravity of the fractional plastic pallet **20**, or at or near the center of the product support surface **32**. In other embodiments, there may be a pair of hand access holes **60**. The pair of hand access holes **60** may be centered within the top deck **30**. Alternatively, the hand access hole **60** is optional such that in other embodiments of the top deck **30** a hand access hole will not be included.

**[0064]** The hand access hole **60** provides an easy means for an operator to handle the fractional plastic pallet **20**. The hand access hole **60** is sized large enough for a user to insert all four fingers of his hand therethrough. By providing the central hand access hole **60** towards the center of the fractional plastic pallet **20**, or at or near the balance point of the fractional plastic pallet **20**, the pallet **20** can very easily be grasped by the user for carrying it or for unloading it from a stack of pallets.

**[0065]** Finger grip details can be provided on one or both long sides of the hand access hole **60**. A rounded end wall may be provided at one or both short ends thereof. A rounding of the finger grips or ends of the hand access hole **60** offers a smoother engagement surface to the user. This also can make the fractional plastic pallet **20** more comfortable when being lifted.

**[0066]** The top deck **30** is formed using ribbing grids **200**, as illustrated in FIG. 3. The ribbing grids **200** advantageously allow the fractional plastic pallet **20** to have a high strength/load capacity. The ribbing grids **200** of the fractional plastic pallet **20** may be configured to handle loads up to 500 pounds, for example.

**[0067]** In addition, the product support surface **32** of the top deck **30** includes an array of frictional points **31** to prevent slippage of products on the product support surface **32**. Each frictional point **31** has a circular shape and is in the form of a raised stub, for example.

**[0068]** The fractional plastic pallet **20** also includes a ridge **39** that extends along the corners of the pallet. The ridge **39** is at the lower edge of sides **36**, **38**. The corners are configured so that they are recessed from the ridge **39**, as shown in FIGS. 1 and 2.

**[0069]** A method for making the above illustrated pallet **20** includes forming a top deck **30** that includes a product support surface **32** and an opposing underside

**34**, and with the product support surface **32** including a pair of pallet support leg receiving areas **160**.

**[0070]** The method further includes forming a pair of pallet support legs **40**. Each pallet support leg **40** includes a center leg section **42** and a pair of leg extensions **44**. The center leg section **42** has a first end and a second end opposite the first end. The pair of leg extensions **44** extend outwards from the second end of the center leg section **42**. An underside of the center leg section **42** and the pair of leg extensions **44** is configured to engage one of the pallet support leg receiving areas **160** of an identical pallet when stacked thereon.

**[0071]** The method further includes coupling the first ends of the center leg sections **42** of the pair of pallet support legs **40** to the underside of the top deck **30**. Each pallet support leg **40** is aligned with a corresponding pallet support leg receiving area **160** in the top deck **30**.

**[0072]** Referring now to FIGS. 10-20, another embodiment is directed to a reconfigurable pallet/dolly platform. The reconfigurable pallet/dolly platform includes a top deck **30'** that may be configured with pallet support legs **40'** to form a pallet **20'** as illustrated in FIGS. 11 and 12, or may be configured with dolly wheels **140'** to form a dolly **120'** as illustrated in FIGS. 13-14.

**[0073]** The top deck **30'** is advantageously reconfigured to support either configuration. The top deck **30'** includes a product support surface **32'** and an opposing underside **34'**. As illustrated in FIG. 15, the underside **34'** includes a pair of pallet support leg attachment areas **310'** for receiving a pair of pallet support legs **40'** when configured as a pallet **520'**. The underside **34'** further includes a plurality of dolly wheel attachment areas **320'** for receiving a plurality of dolly wheels **140'** when configured as a dolly **120'**.

**[0074]** As illustrated in FIG. 16, the product support surface **32'** includes a pair of pallet support leg receiving areas **160'** aligned with the pair of pallet support leg attachment areas **310'** and configured to engage the pair of pallet support legs **40'** from an identical platform stacked thereon when configured as a pallet **20'**. The product support surface **32'** further includes a plurality of dolly wheel receiving areas **330'** aligned with the plurality of dolly wheel wells **320'** and configured to engage the plurality of dolly wheels **140'** from an identical platform stacked thereon when configured as a dolly **120'**. Each dolly wheel attachment area **320'** includes four

attachment points **322'** for securing a dolly wheel **140'**.

**[0075]** There are four dolly wheel wells **330'** in the product support surface **32'**, one for each dolly wheel **140'**. Each dolly wheel well **330'** is adjacent to a pallet support leg receiving area **160'**. By having the dolly wheel wells **330'** receiving the dolly wheels **140'** from a stacked dolly **120'**, stability is provided as the stacked dollies **120'** are moved.

**[0076]** In particular, each dolly wheel well **330'** overlaps a corner portion **210'** of the pallet support leg receiving area **160'**. The corner portion **210'** of the pallet support leg receiving area **160'** is recessed to complete the outline of the dolly wheel well **330'**.

**[0077]** There are two dolly wheel wells **330'** adjacent each pallet support leg receiving area **160'**. In addition, each dolly wheel well **330'** includes a drainage opening **212'** so that water or other liquids do not accumulate within the dolly wheel wells **330'**. The dolly wheels **140'** at one end of the dolly **120'** can swivel about an axis perpendicular to the top deck **30'**, whereas the dolly wheels **140'** at the other end of the dolly **120'** do not swivel. Alternatively, all the dolly wheels **140'** can swivel.

**[0078]** The pallet support leg receiving areas **160'** are recessed within the product support surface **32'** of the top deck **30'**. Each pallet support leg receiving area **160'** is sized slight larger than the lowermost surface **170'** of a pallet support leg **40'**. By having the pallet support leg receiving areas **160'** receive pallet support legs **40'** from a stacked pallet **20'**, stability is provided as the stacked pallets **20'** are moved.

**[0079]** Each pallet support leg receiving area **160'** includes a pattern of spaced apart protrusions matching a corresponding pattern of spaced apart protrusion openings in an underside **170'** of each pallet support leg **40'**. The spaced apart protrusions include four rectangular-shaped protrusions **214'** in the center of the pallet support leg receiving area **160'** as illustrated in FIG. 16. The spaced apart protrusions further include a plurality of smaller square-shaped protrusions **216'** on each side of the four rectangular-shaped protrusions **214'** within the pallet support leg receiving area **160'**.

**[0080]** One end **218'** of each rectangular-shaped protrusion **214'** is angled or sloped. The other end **220'** of each rectangular-shaped protrusion **214'** is not angled or sloped and includes a portion removed so that the other end **220'** is narrower than

end **218'**. The four rectangular-shaped protrusions **214'** are for engaging a corresponding pattern of four rectangular-shaped protrusion openings **230'** on the underside **170'** of each pallet support leg **40'** as illustrated in FIG. 15.

**[0081]** Adjacent the four rectangular-shaped protrusions **214'** are four access openings **225'** to permit a tool to be used to separate a pallet support leg **40'** when engaged with the pallet support leg receiving area **160'**. The access openings **225'** are along an edge of the pallet support leg receiving areas **160'**. The access openings **225'** also extend into the product support surface **32'** of the top deck **30'**. The access openings **225'** also extend through the top deck **30'** so as to prevent water or other liquids from accumulating within the pallet support leg receiving areas **160'**.

**[0082]** Each pallet support leg **40'** includes a center leg section **42** and a pair of leg extensions **44'**, as illustrated in FIG. 17. The center leg section **42'** has a first end and a second end opposite the first end. The pair of leg extensions **44'** extend outwards from the second end of the center leg section **42'**.

**[0083]** The underside **34'** of the top deck **30'** includes a pair of center leg section openings **340'**, as illustrated in FIG. 18. Each center leg section opening **340'** is to receive the first end of one of the center leg sections **42'** when configured as a pallet **20'**.

**[0084]** Each center leg section opening **340'** is separated by a divider **342'**, and wherein the first end of each center leg section **42'** is slotted **346'** to receive the divider **342'**. Also, each center leg section opening **340'** includes a plurality of locking tab openings **350'** for engaging a plurality of locking tabs **352'** on one of the center leg sections **42'**.

**[0085]** Each pallet support leg **40'** includes a reinforcement member **361'** that extends through each leg extension **44'** and the center leg section **42**. Openings within the leg extensions **44'** exposes the reinforcement member **361'**. The reinforcement member **361'** may be steel, for example. A respective clip **360'** is coupled to each leg extension **44'** to enclose an exposed end of the reinforcement member **361'**.

**[0086]** The top deck **30'** also includes a pair of reinforcement members **363'** that extends from one side of the top deck **30'** to the other side. Openings within the top deck **30'** exposes the reinforcement members **363'**. The reinforcement members

**361'** may be steel, for example. Clips **362'** are coupled to the top deck **30'** to enclose exposed ends of the reinforcement member **363'**.

**[0087]** Each pallet support leg receiving area **160'** has a length within a range of 75% to 95% of the length of the top deck **30'**, and a width within a range of 10% to 20% of a width of the top deck **30'**. Also, a length of each center leg section opening **350'** is within a range of 30% to 40% of an overall length of each pallet support leg receiving area **160'**.

**[0088]** A method for making the above illustrated pallet reconfigurable pallet/dolly platform includes forming a top deck **30'** that includes a product support surface **32'** and an opposing underside **34'**.

**[0089]** The underside **34'** includes a pair of pallet support leg attachment areas **310'** for receiving a pair of pallet support legs **40'** when configured as a pallet **20'**. The underside **34'** also includes a plurality of dolly wheel attachment areas **320'** for receiving a plurality of dolly wheels **140'** when configured as a dolly **120'**.

**[0090]** The product support surface **32'** includes a pair of pallet support leg receiving areas **160'** aligned with the pair of pallet support leg attachment areas **310'** and configured to engage the pair of pallet support legs **40'** from an identical platform stacked thereon when configured as a pallet **20'** as illustrated in FIG. 19.

**[0091]** The product support surface **32'** also includes a plurality of dolly wheel attachment areas **320'** aligned with the plurality of dolly wheel wells **330'** and configured to engage the plurality of dolly wheels **140'** from an identical platform stacked thereon when configured as a dolly as illustrated in FIG. 20.

**[0092]** The top deck **30, 30'** may be configured with provisions to enable attachment of an electronic tracking device. A compartment, for example, may be formed or attached to an underside of the top deck **30, 30'** to carry the electronic tracking device. Fasteners may be used for the attachment, including screws or other hardware, plastic clips, or a combination thereof. The electronic tracking device may be configured to store data during pallet use. The electronic tracking device may include, but is not limited to, communication protocols such as Bluetooth, Bluetooth Low Energy (BLE), RFID, cellular, and GPS.

**[0093]** The top deck **30, 30'** may be configured to include channels or openings for receiving reinforcing members. The reinforcing members improve the overall performance and strength of the top deck **30, 30'**. The reinforcing members

may be formed with various materials, including but not limited to steel and other metals.

**[0094]** Many modifications and other embodiments of the invention will come to the mind of one skilled in the art having the benefit of the teachings presented in the foregoing descriptions and the associated drawings. Therefore, it is understood that the invention is not to be limited to the specific embodiments disclosed, and that modifications and embodiments are intended to be included within the scope of the foregoing description.

CLAIMS

1. A pallet comprising:
  - a top deck including a product support surface and an opposing underside, and with the product support surface including a pair of pallet support leg receiving areas; and
  - a pair of pallet support legs on the underside of said top deck and aligned with the pallet support leg receiving areas, each pallet support leg including:
    - a center leg section having a first end adjacent the underside of said top deck, and a second end opposite the first end, with the center leg section spaced from all sides of said top deck to allow four way entry with pallet handling equipment,
    - a pair of leg extensions extending outwards from the second end of the center leg section, with each leg extension forming a gap between the underside of said top deck to allow entry with the pallet handling equipment, and
    - with an underside of the center leg section and the pair of leg extensions configured to engage one of the pallet support leg receiving areas of an identical pallet when stacked thereon.
2. The pallet according to Claim 1 wherein each pallet support leg receiving area is recessed from the product support surface.
3. The pallet according to Claim 1 wherein an underside of said pair of pallet support legs is configured to interlock with the pair of pallet support leg receiving areas of the identical pallet when stacked thereon.
4. The pallet according to Claim 3 wherein each pallet support leg receiving area includes a pattern of spaced apart protrusions matching a corresponding pattern of spaced apart protrusion openings in the underside of each pallet support leg.

5. The pallet according to Claim 1 wherein said pair of pallet support legs is configured to removably couple to the underside of said top deck.

6. The pallet according to Claim 1 wherein the underside of said top deck includes a pair of center leg section openings, with each center leg section opening to receive the first end of one of the center leg sections.

7. The pallet according to Claim 6 wherein each center leg section opening is separated by a divider, and wherein the first end of each center leg section is slotted to receive the divider.

8. The pallet according to Claim 6 wherein each center leg section includes a plurality of locking tabs for engaging a plurality of locking tab openings within each center leg section opening.

9. The pallet according to Claim 1 wherein each pallet support leg has a length within a range of 75% to 95% of a length of said top deck, and a width within a range of 10% to 20% of a width of said top deck.

10. The pallet according to Claim 1 wherein a length of each center leg section is within a range of 30% to 40% of an overall length of each pallet support leg.

11. The pallet according to Claim 1 wherein said top deck has a length of 24 inches and a width of 20 inches.

12. The pallet according to Claim 1 wherein said top deck includes at least one product display attachment slot configured to receive at least one product display.

13. The pallet according to Claim 1 wherein each pallet support leg comprises a reinforcement member that extends through each leg extension and the center leg section, and a respective clip coupled to each leg extension to enclose an exposed end of the reinforcement member.

14. A method for making a pallet comprising:

forming a top deck including a pallet support surface and an opposing underside, and with the product support surface including a pair of pallet support leg receiving areas;

forming a pair of pallet support legs, with each pallet support leg including:

a center leg section having a first end and a second end opposite the first end, with the center leg section spaced from all sides of said top deck to allow four way entry with pallet handling equipment,

a pair of leg extensions extending outwards from the second end of the center leg section, with each leg extension forming a gap between the underside of said top deck to allow entry with the pallet handling equipment, and

with an underside of the center leg section and the pair of leg extensions configured to engage one of the pallet support leg receiving areas of an identical pallet when stacked thereon; and

coupling the first ends of the center leg sections of the pair of pallet support legs to the underside of the top deck, with the pair of pallet support legs being aligned with the pallet support leg receiving areas in the top deck.

15. The method according to Claim 14 wherein each pallet support leg receiving area is recessed from the product support surface.

16. The method according to Claim 14 wherein an underside of the pair of pallet support legs is configured to interlock with the pair of pallet support leg receiving areas of the identical pallet when stacked thereon.

17. The method according to Claim 16 wherein each pallet support leg receiving area includes a pattern of spaced apart protrusions matching a corresponding pattern of spaced apart protrusion openings in the underside of each pallet support leg.

18. The method according to Claim 14 wherein the pair of pallet support legs is configured to be removably coupled to the underside of the top deck.

19. The method according to Claim 14 wherein the underside of the top deck includes a pair of center leg section openings, with each center leg section opening to receive the first end of one of the center leg sections.

20. The method according to Claim 14 wherein forming each pallet support leg further comprises inserting a reinforcement member through each leg extension and the center leg section, and coupling a respective clip to each leg extension to enclose an exposed end of the reinforcement member.

**CHEP Technology Pty Limited**  
**Patent Attorneys for the Applicant/Nominated Person**  
**SPRUSON & FERGUSON**

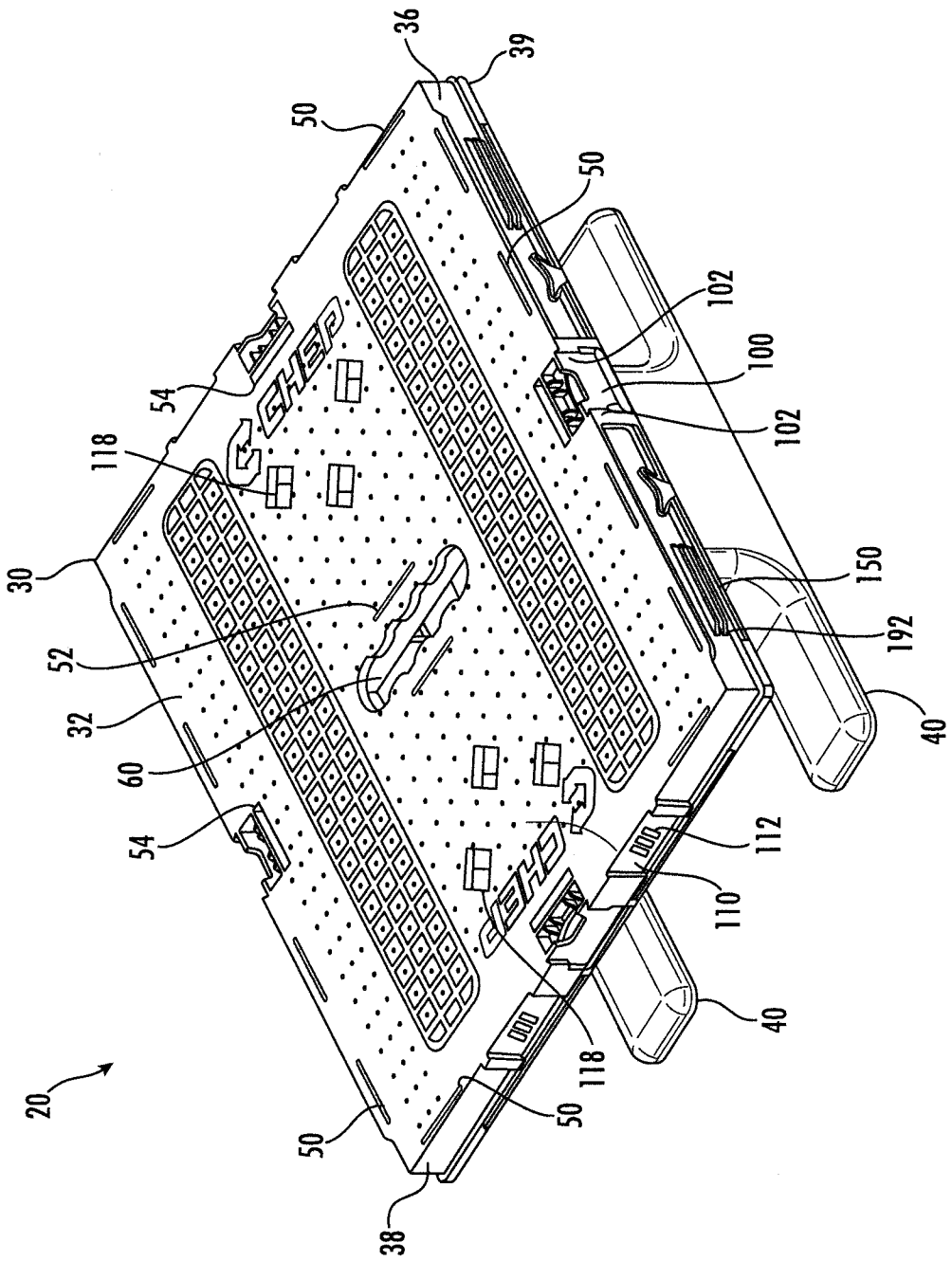

FIG. 1

2/20

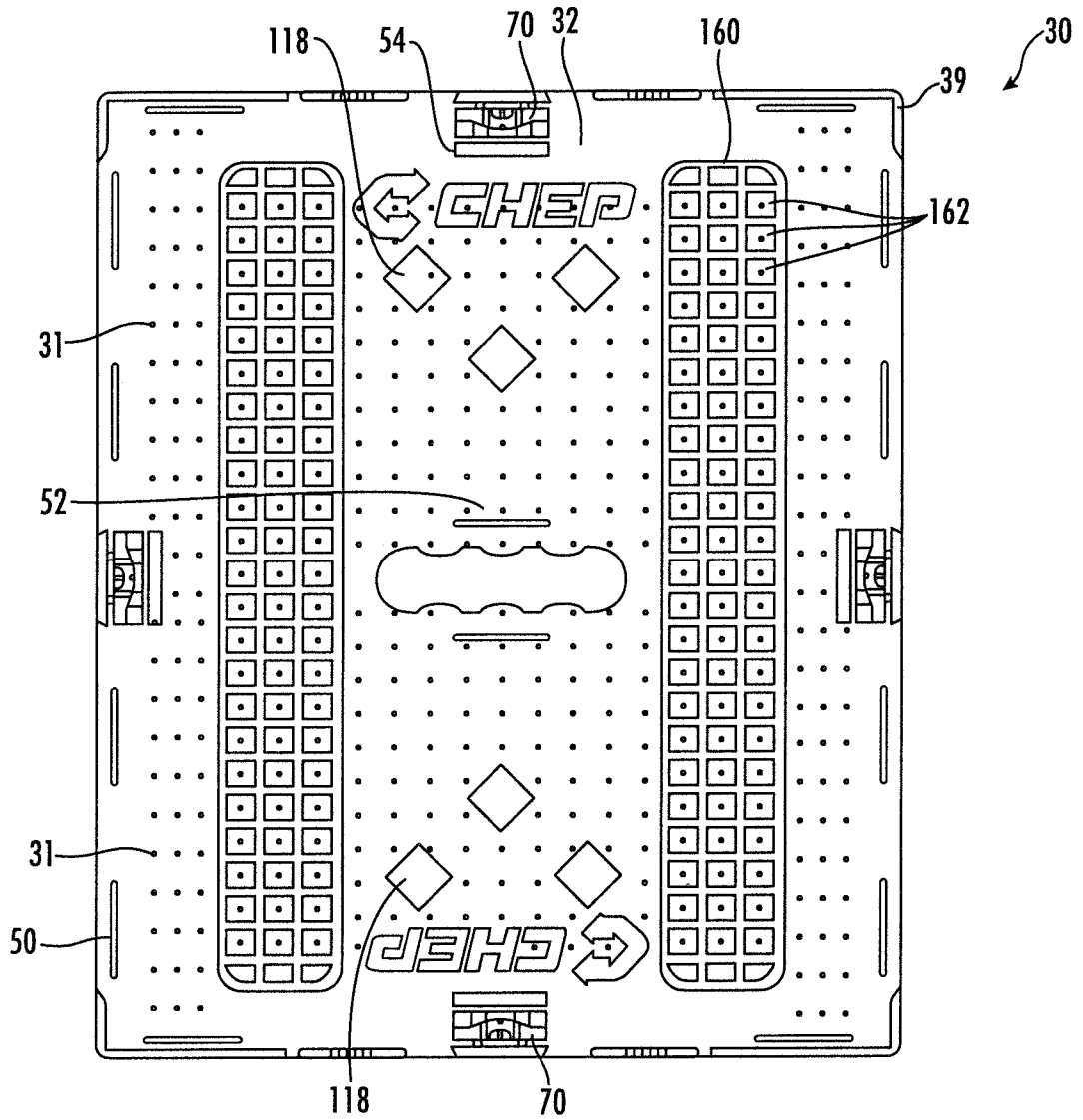

FIG. 2

3/20

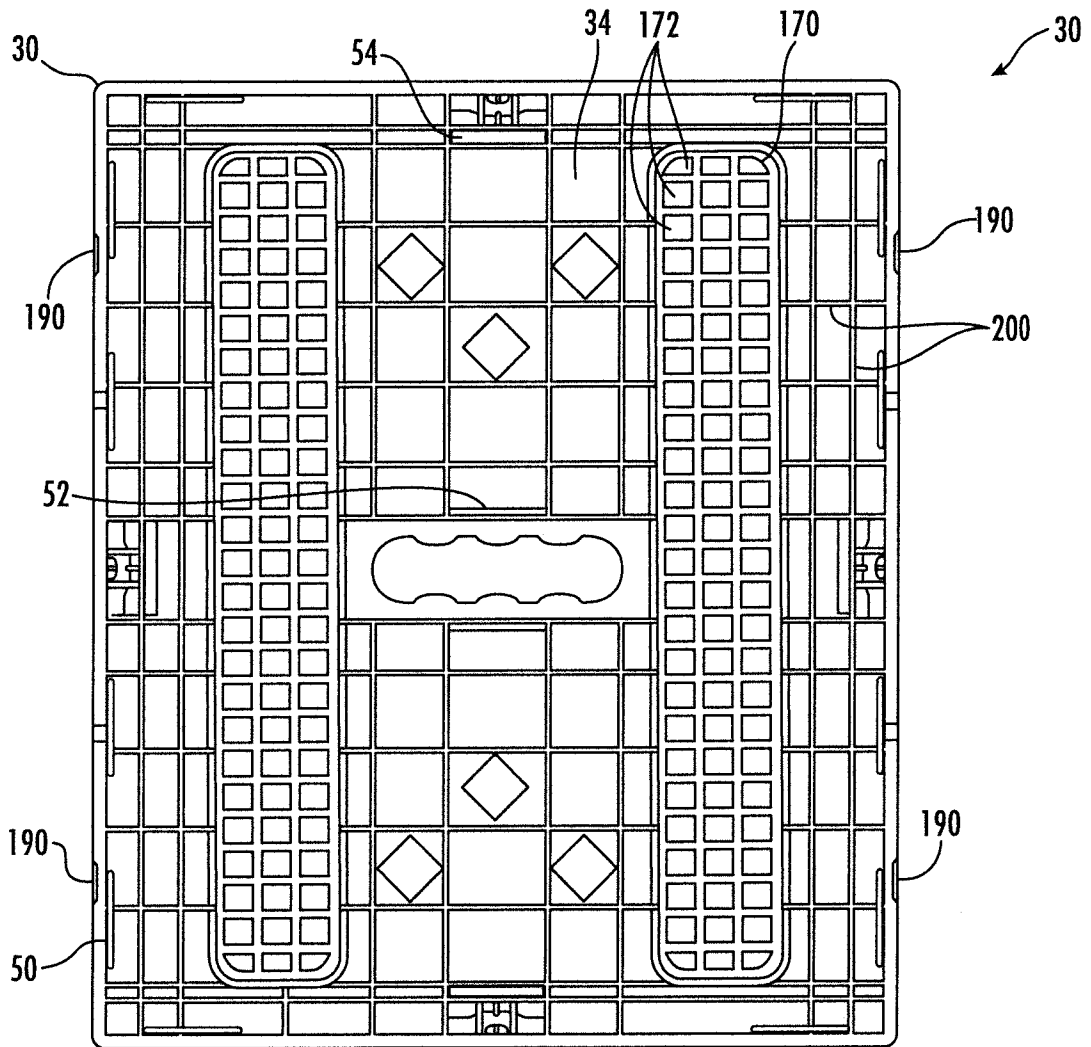

FIG. 3

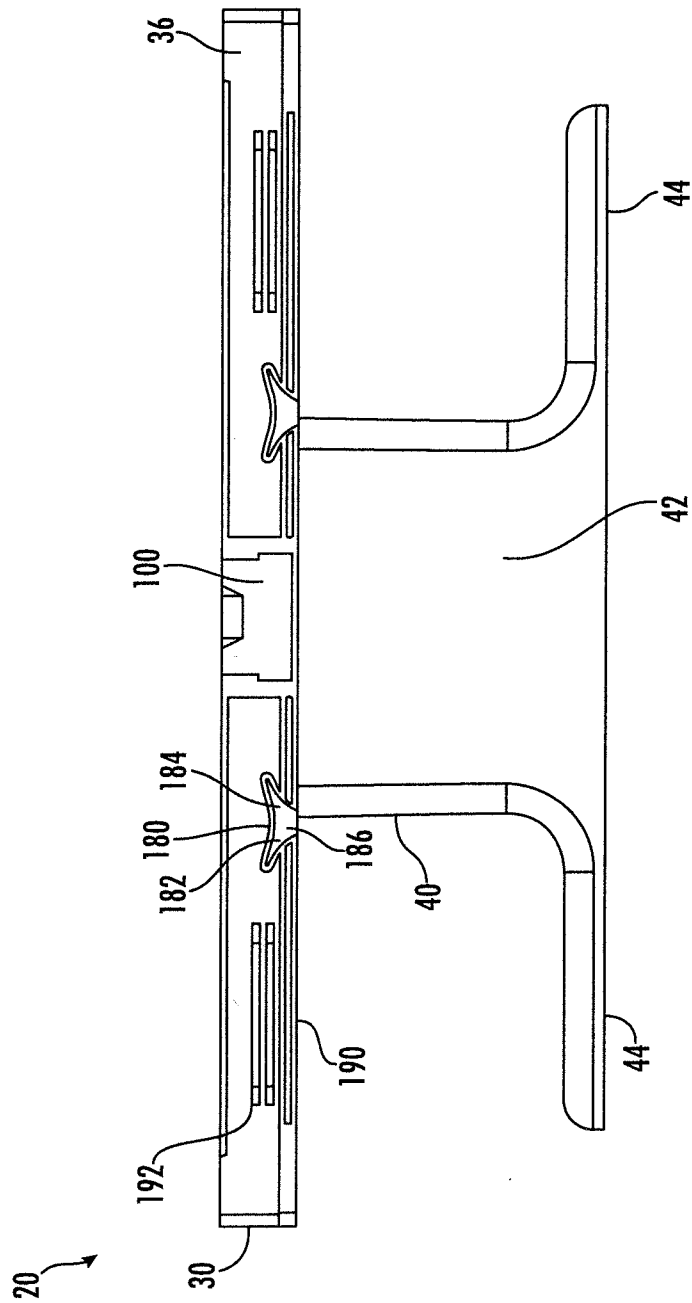

FIG. 4

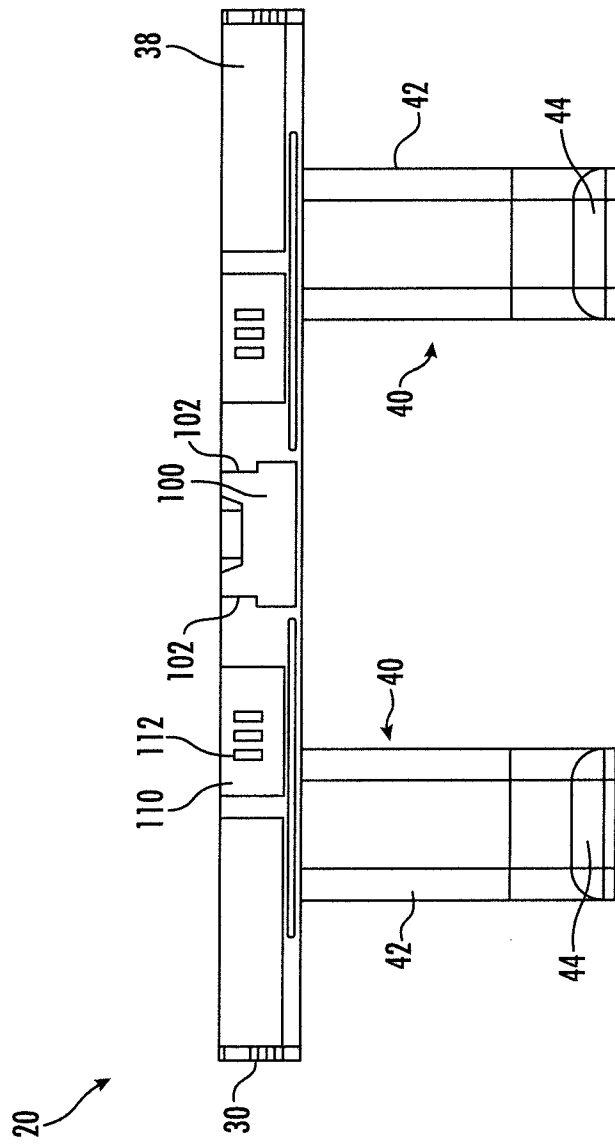

FIG. 5

6/20

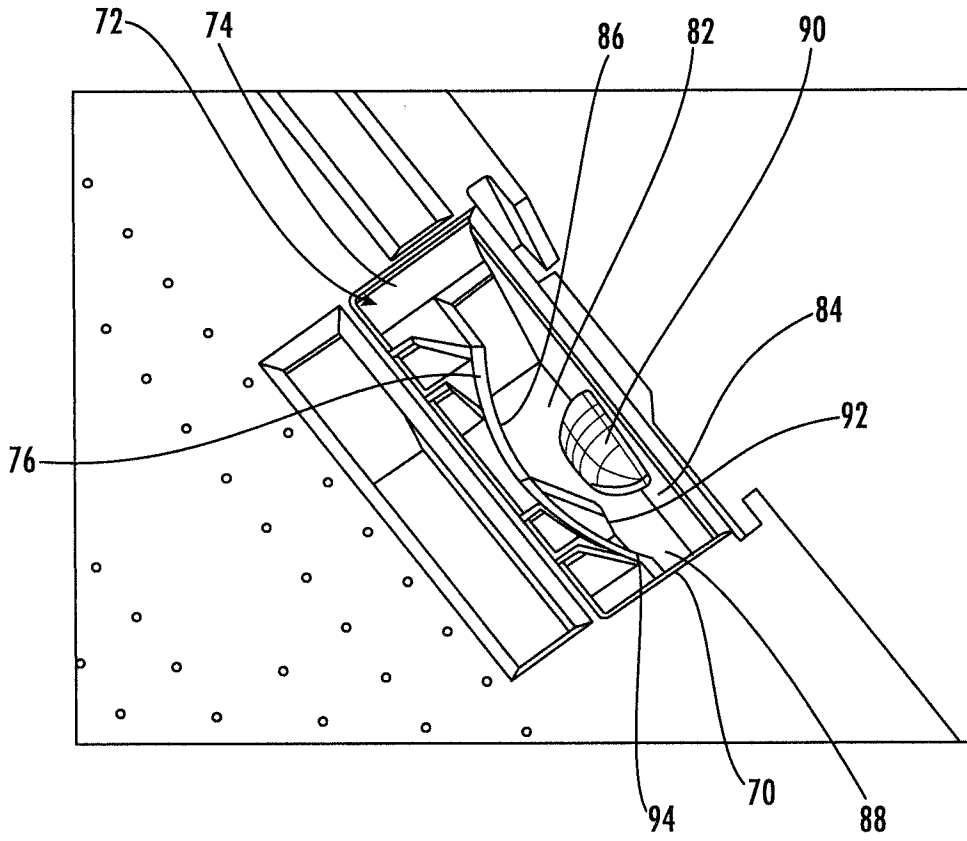

FIG. 6

7/20

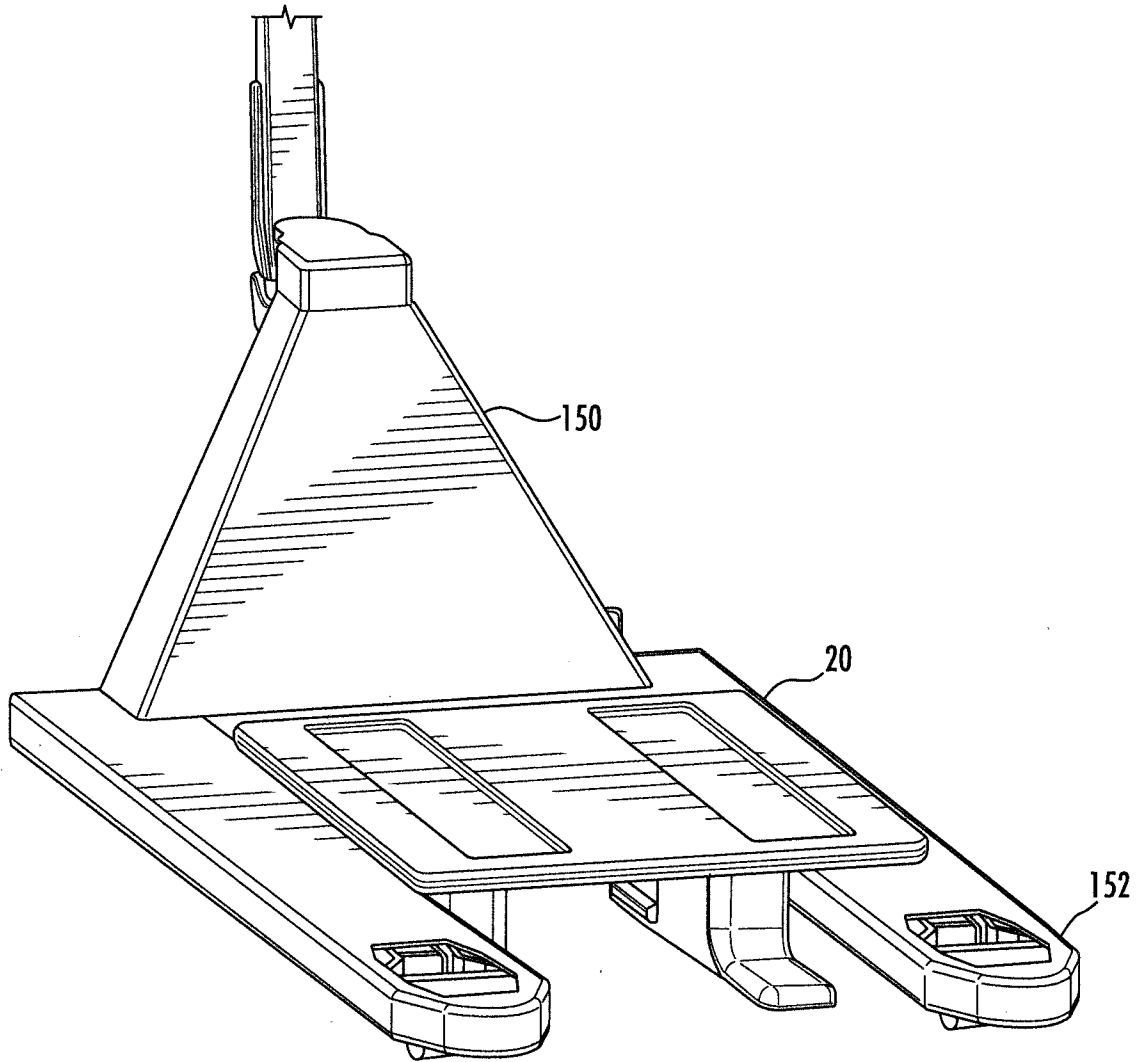

FIG. 7

8/20

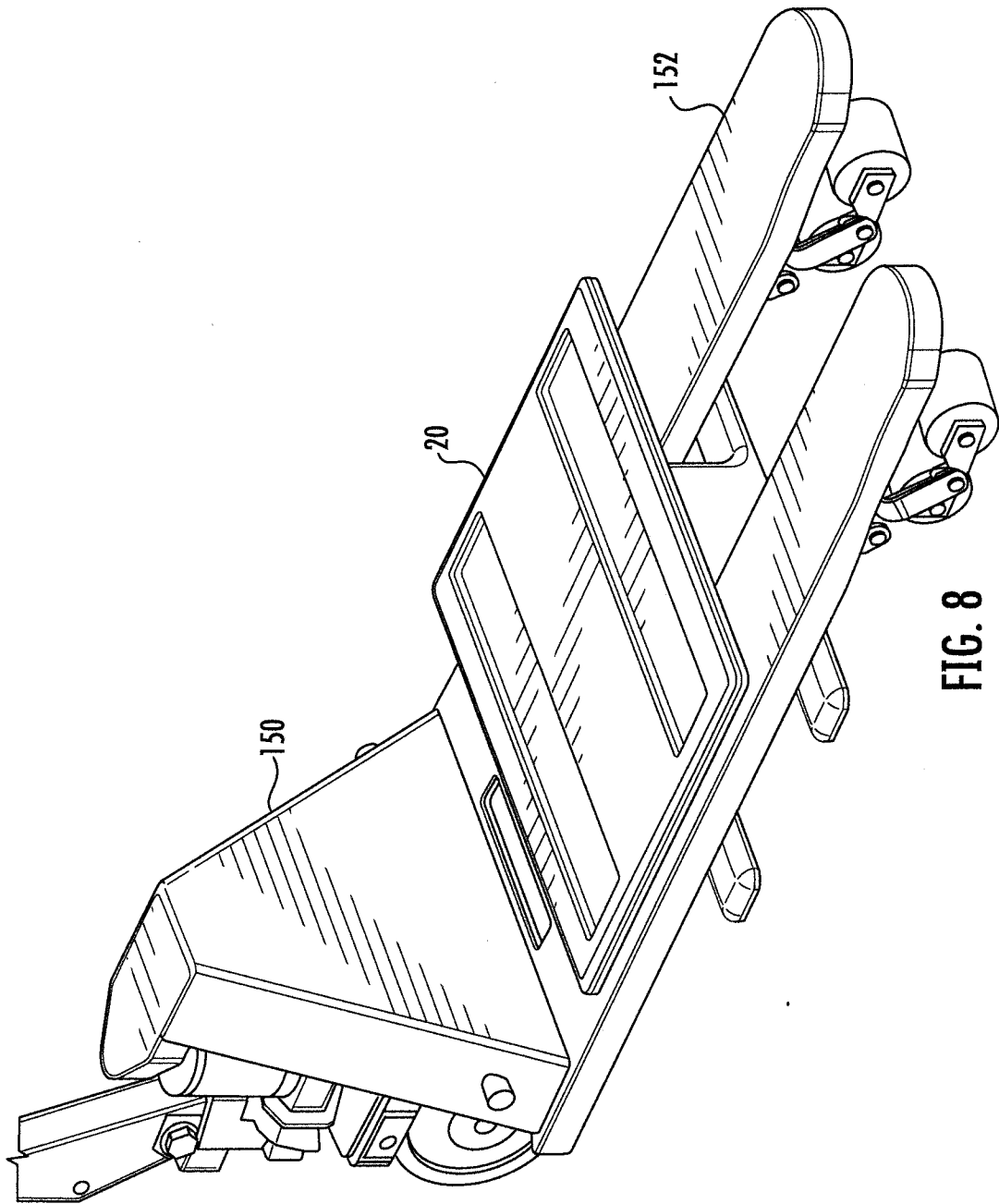

FIG. 8

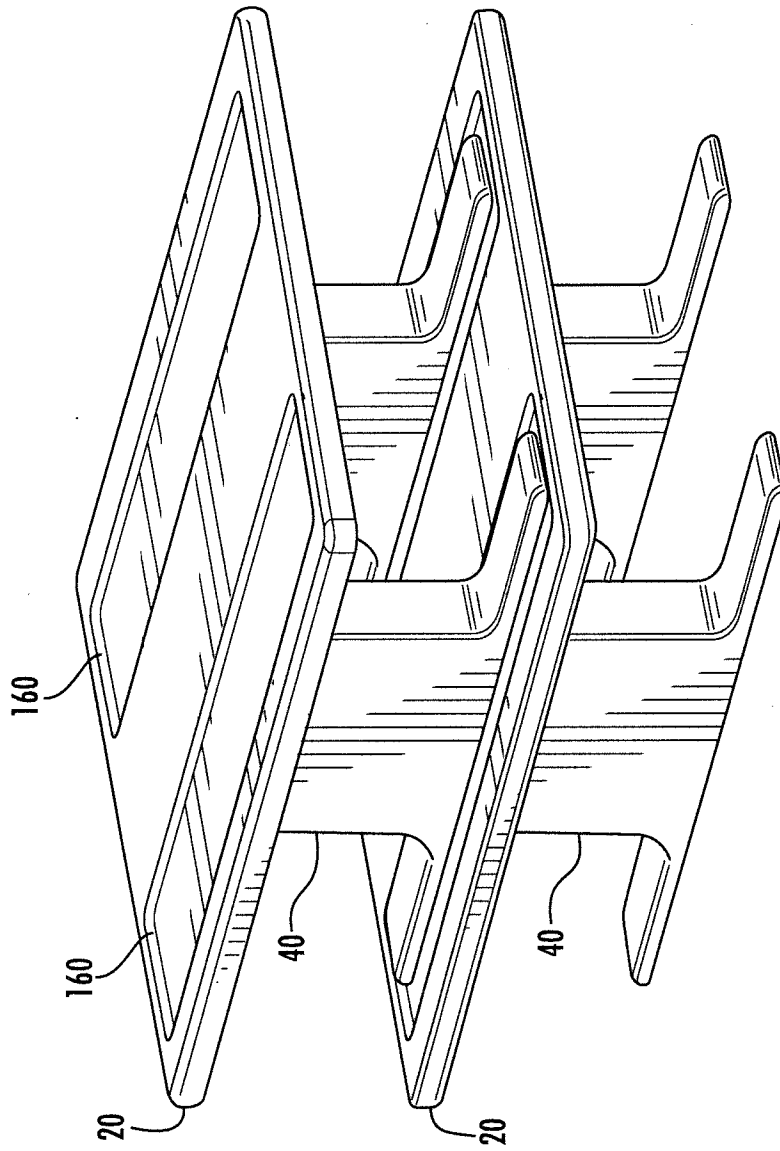

FIG. 9

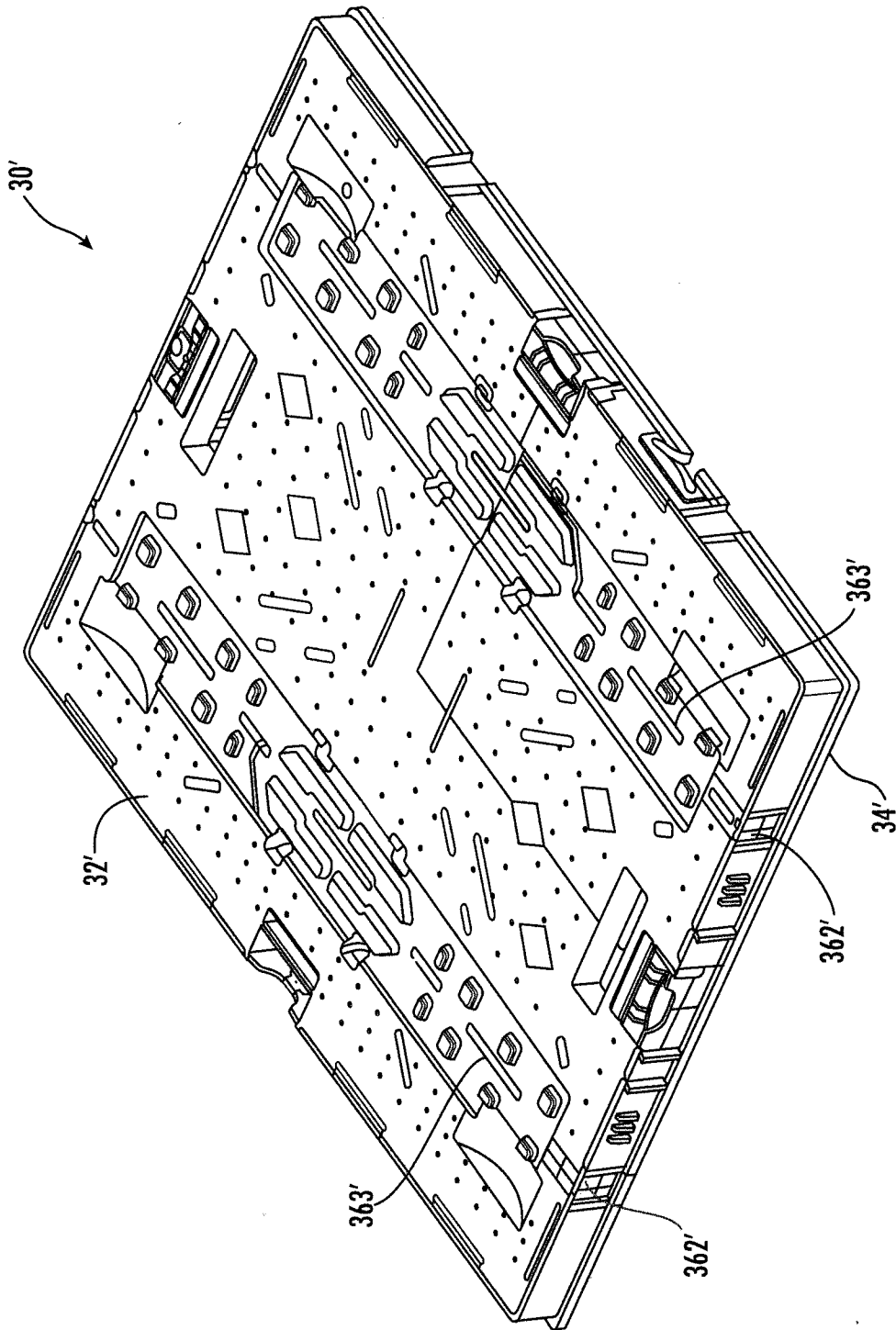

FIG. 10

11/20

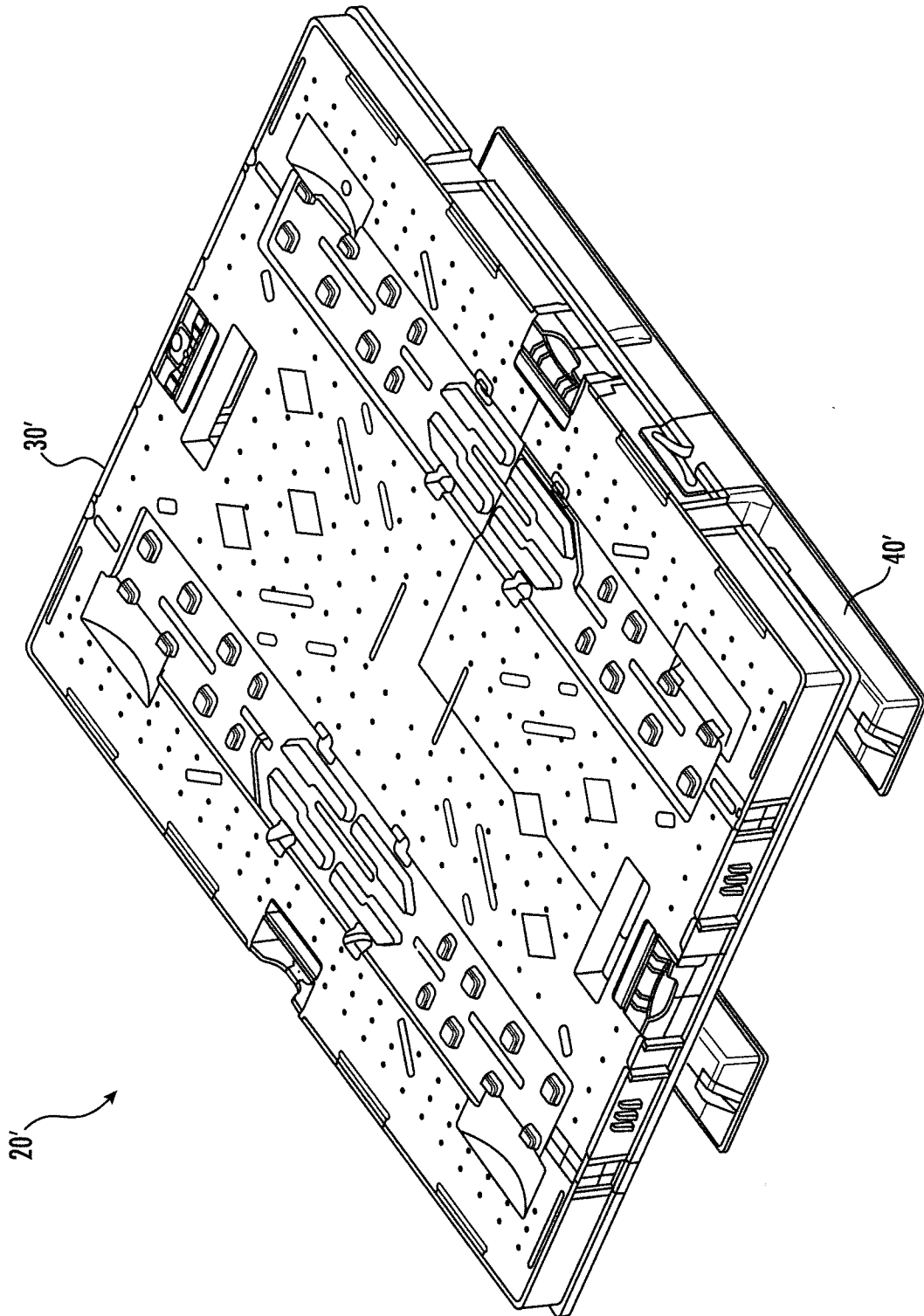

FIG. 11

12/20

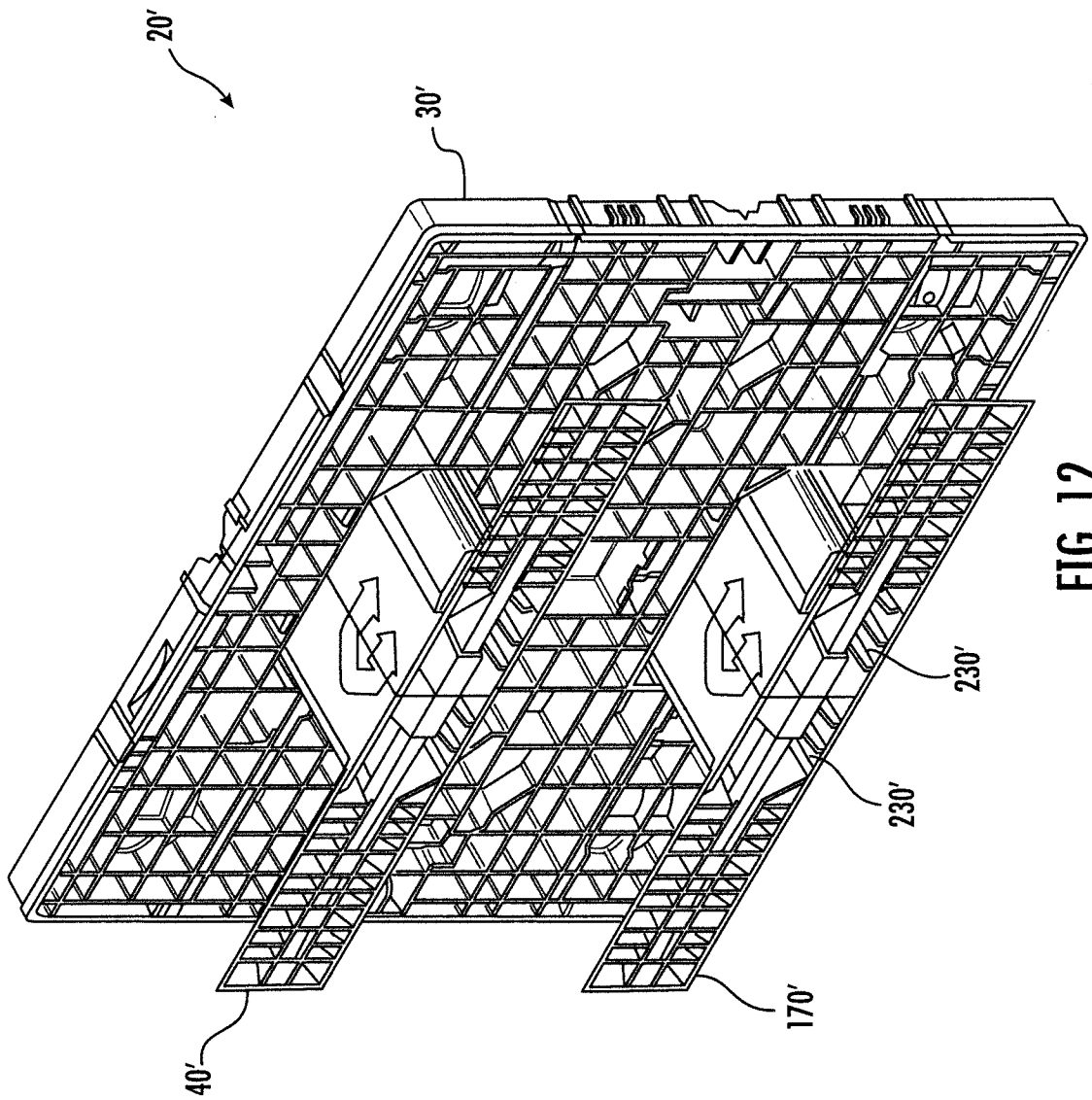

FIG. 12

13/20

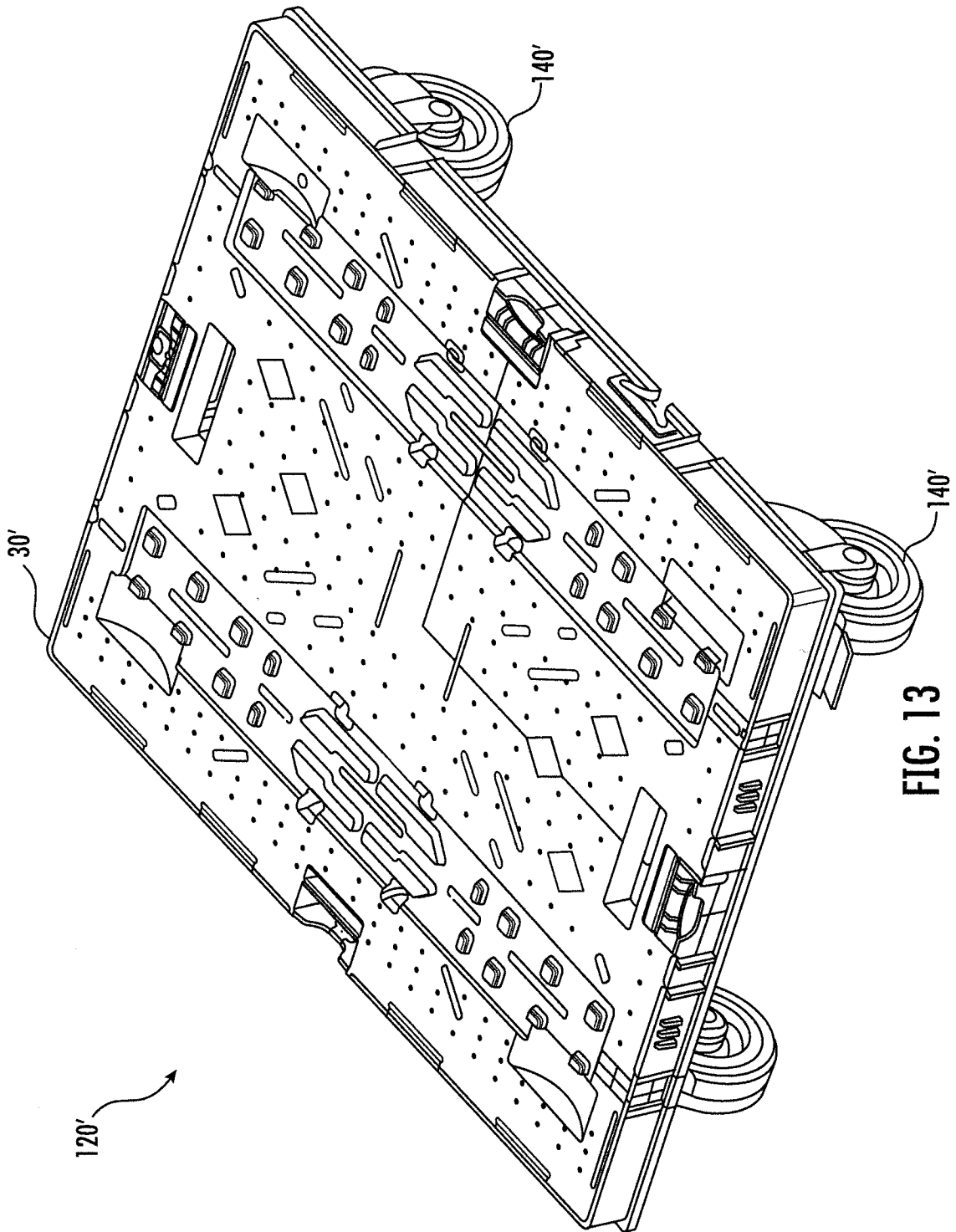

FIG. 13

14/20

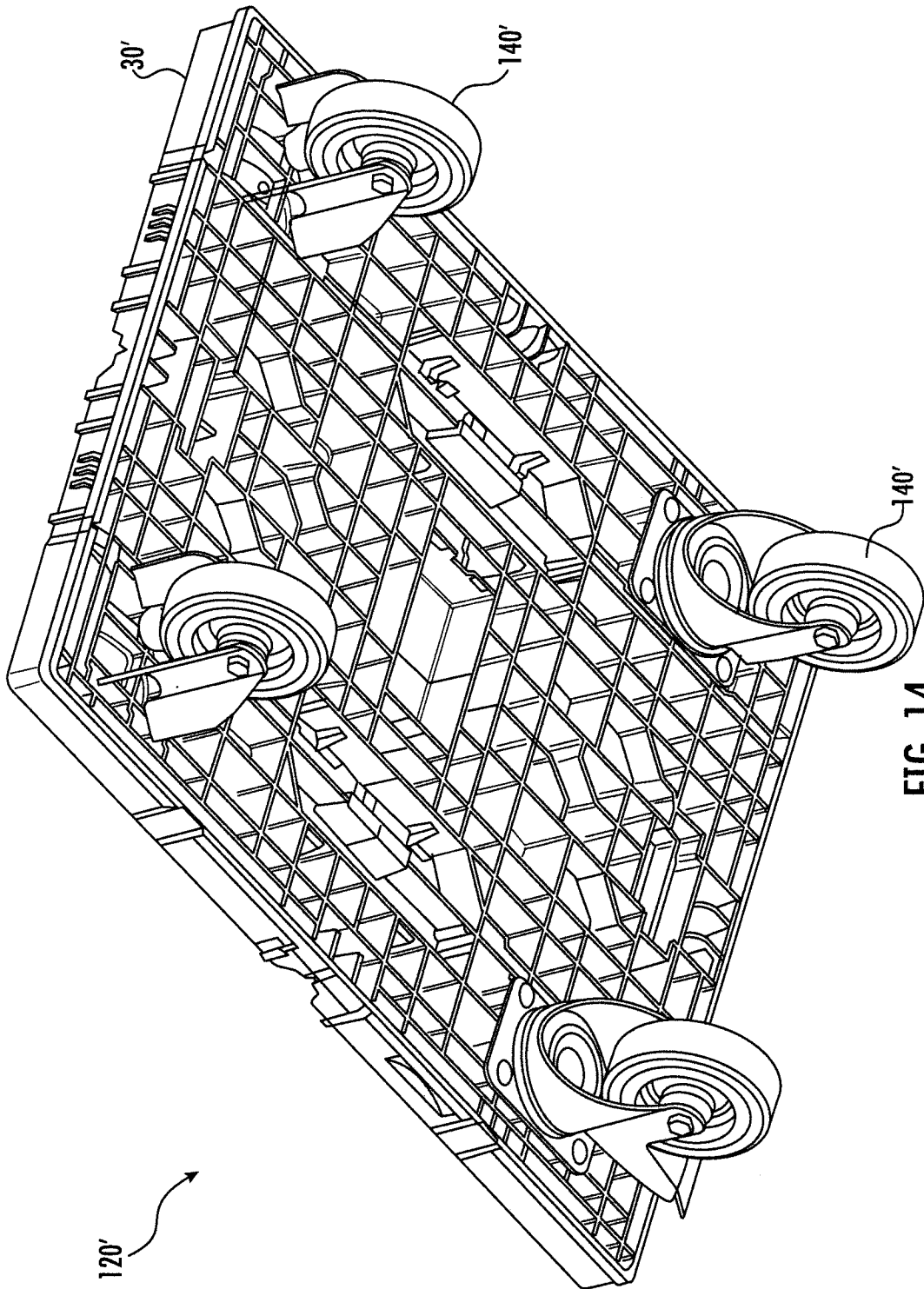

FIG. 14

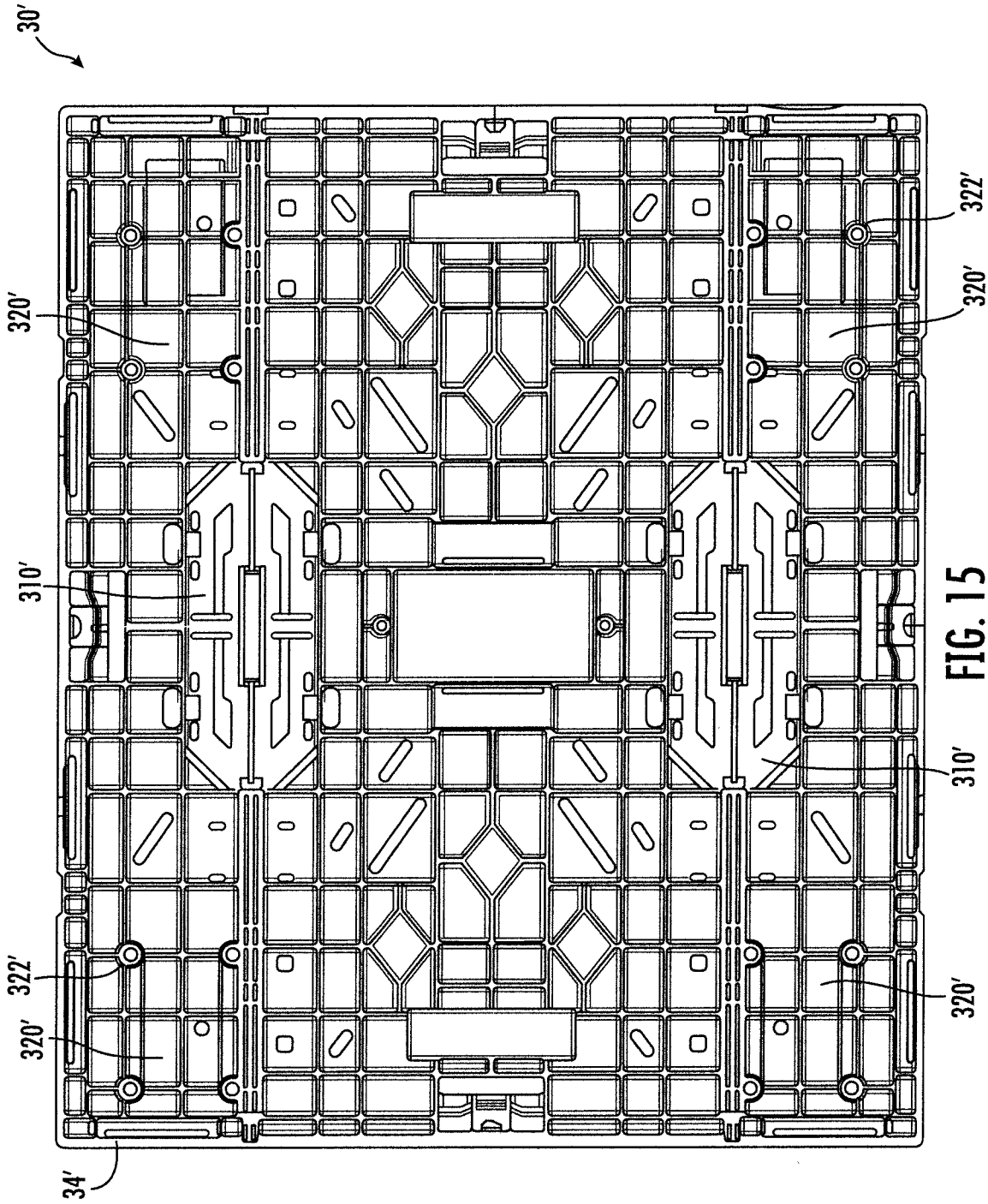

FIG. 15

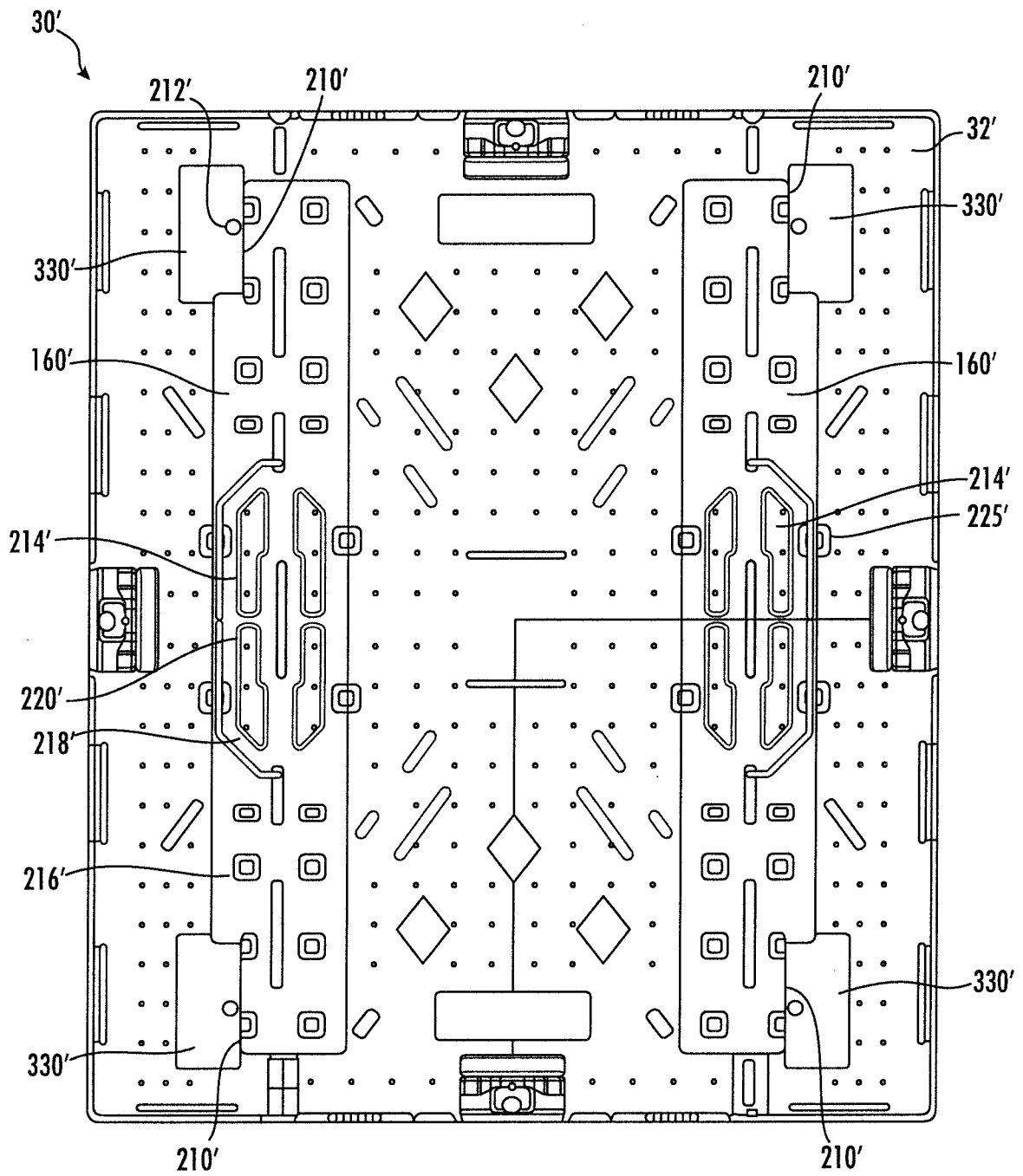

FIG. 16

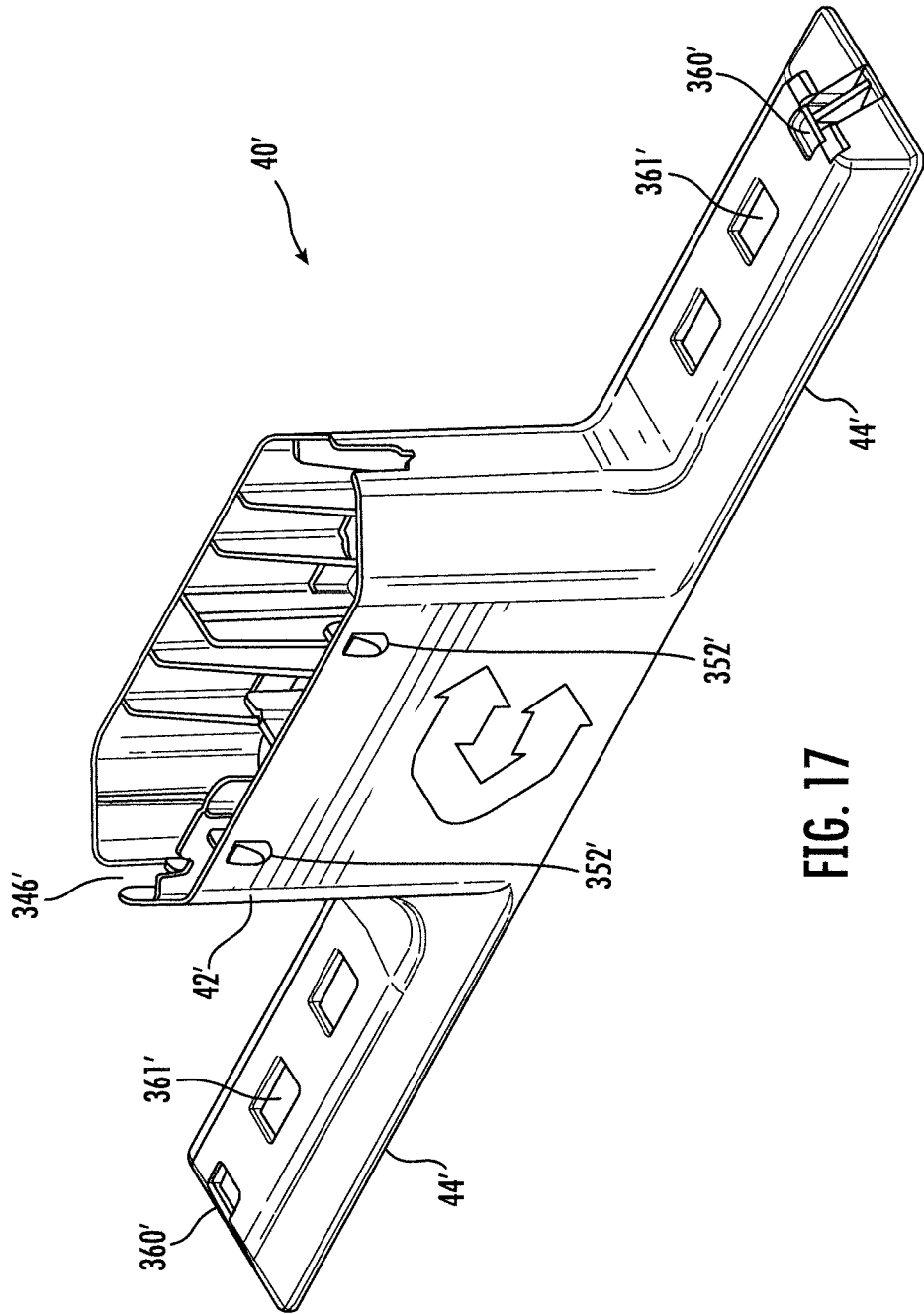

FIG. 17

18/20

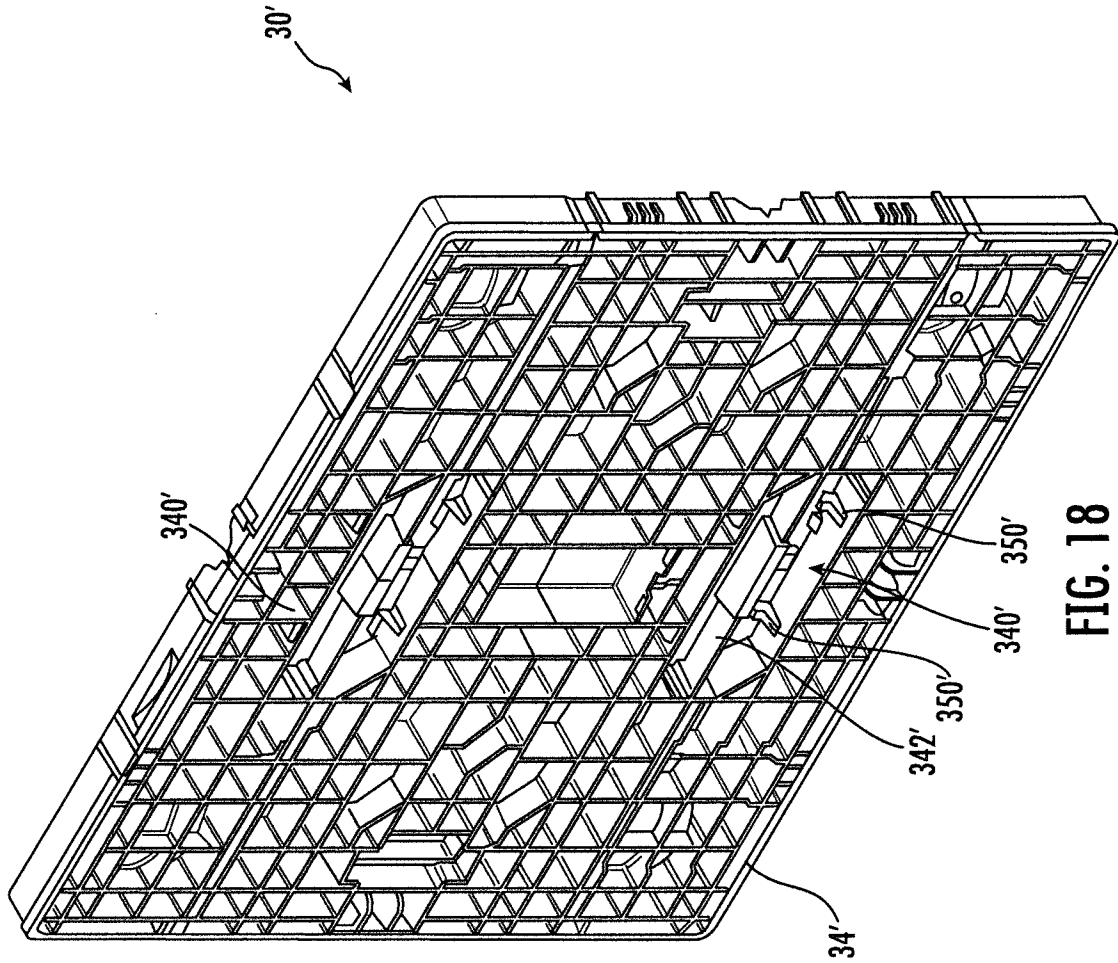

FIG. 18

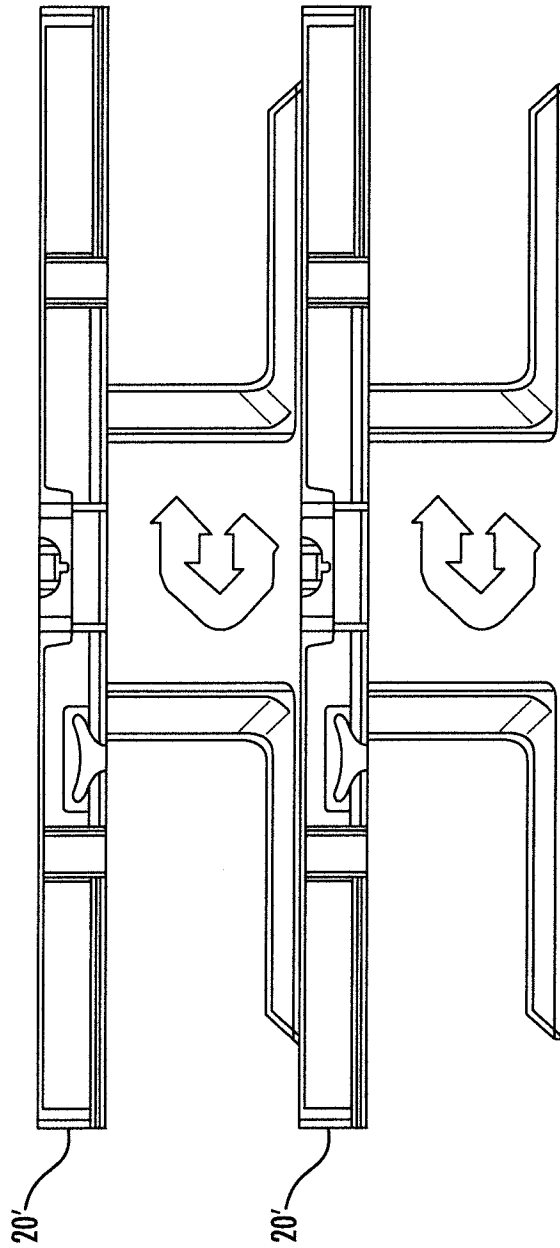

FIG. 19

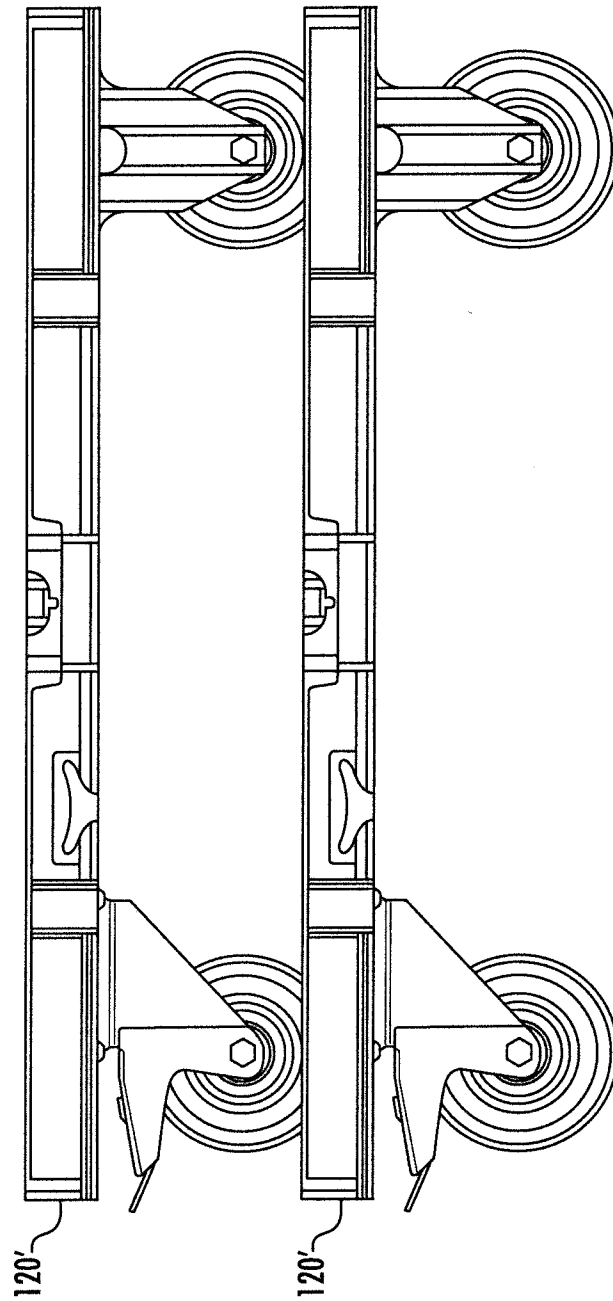

FIG. 20