

M. WINGER.  
Machine for Shaving Bark.

No. 108,668.

Patented Oct. 25, 1870.

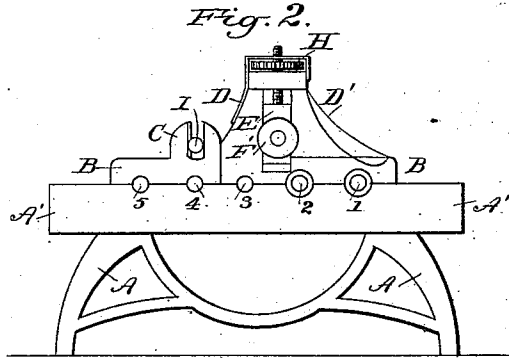
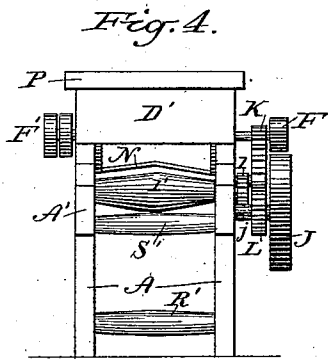
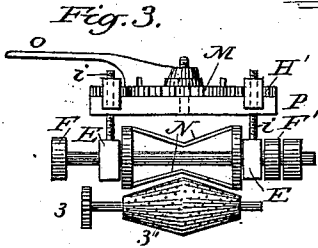
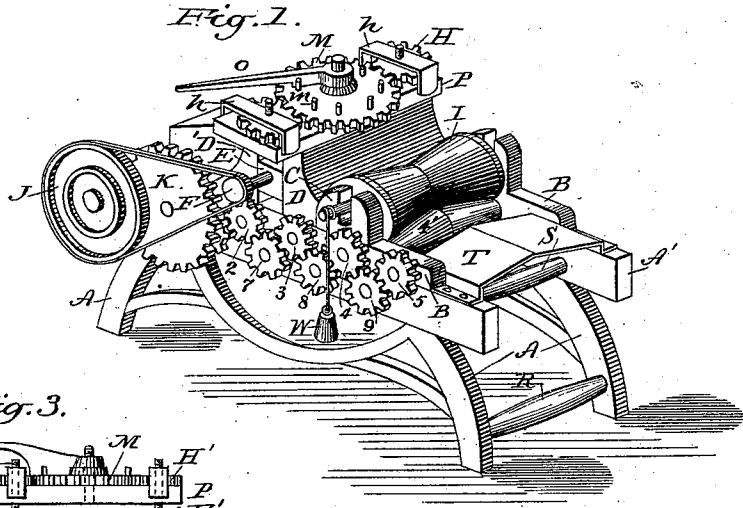

Witnesses:

Emma R. Seltzer  
W. K. Seltzer

Inventor:

Martin Winger

# United States Patent Office.

MARTIN WINGER, OF EPHRATA, PENNSYLVANIA.

Letters Patent No. 108,668, dated October 25, 1870.

## IMPROVEMENT IN BARK-SHAVING MACHINES.

The Schedule referred to in these Letters Patent and making part of the same

I, MARTIN WINGER, of Ephrata, in the county of Lancaster and State of Pennsylvania, have invented certain Improvements upon the Bark-Shaving Machine for which Letters Patent were granted Nov. 29, 1859, No. 26,317, of which the following is a specification.

The nature of my improvement consists in doing away with the traveling-bed, and the mode of adjustment of the series of knives, and the introduction of a series of rollers operated in unison by a double series of cog-gearing, altogether giving the machine greater durability and efficiency.

The accompanying drawing illustrates the construction and arrangement of the improved machine.

Figure 1 is a perspective view of the entire machine, showing one end and one side.

Figure 2, a side elevation of the opposite side seen in fig. 1.

Figure 3 shows the knives and mode of adjustment.

Figure 4 the rear end view.

A, the supports or legs A, the horizontal side-bearing for the rollers, each provided with a cogged-pinion of equal size and number of cogs, marked 1, 2, 3, 4, and 5, from the rear forward.

No. 1 of the series being on the shaft of the larger cog-wheel K, which derives motion from a pinion, L, back of and on the same shaft which carries the larger strap-pulley J, which latter is actuated by a strap or belt around a pulley, F, on the shaft which supports the knives.

The opposite end of this knife-shaft has a loose and also a driving-pulley, F', to which the power is applied. Four or more knives affixed to circular-heads around the shaft aforesaid, with its belt-pulleys.

This shaft has sliding-bearings, E, or boxes moving up or down in a grooved slot between the supports D D'.

These boxes, E, have each a stationary screw, *i*, which extends upward through the head-block P, and enter a cogged-nut, H, on each side upon the head-block P, held in bearings *h*, under which they turn, having, also, an opening for the passage of the screw when the knife-shaft is raised.

A larger central cog-wheel, M, is provided with a lever, O, and lugs, *m*, against which the lever locks to hold or turn the wheel M.

The cogged-nuts or pinions H have a female-screw,

so that by turning the larger cogged-wheel both the pinions H are moved in unison, by the use of a right-and-left screw, and raise or lower the knife-shaft at pleasure, to adjust it to the thickness of the bark to be shaved.

The five rollers 1, 2, 3, 4, and 5, lie in a horizontal line and form a revolving-bed by each roller moving on its own axis.

The feed-table T, upon which the bark is laid and fed under the upper roller I, the pressure of which is regulated by means of a suspended weight, W, on each end of the projecting shaft, and prevents the bark from turning up on its passage to the revolving-knives.

The front and rear casing D D' also prevents the flying out of dust and chips, and aids in the operation otherwise.

The roller 4 has, centrally, a row of points to aid in the feeding.

The roller 3 is provided with numerous series of short-pointed spikes to hold the bark firmly under the action of the revolving-knives.

R R' and S S' are stout cross-braces to the framework.

I have shown the knives and rollers made bevel or slightly V-shaped, differing in that respect but little from the rotary-knives shown in my patent No. 26,317, November 29, 1859.

I used, also, four pressure-rollers in combination with a convex traveling-bed, or endless-chain arrangement.

I also employed a frame for adjusting the knife-shaft with stationary screw-nuts and revolving-screws, which was more expensive and not so durable and satisfactory as the mode herein adopted, whether the knives are rounded or beveled.

I do not claim any of the parts independently considered, but

What I claim as my invention, and desire to secure by Letters Patent, is—

The series of rolls 1, 2, 3, 4, 5, and I, in combination with the cutters N and their adjusting mechanism, as shown and described.

MARTIN WINGER.

Witnesses:

W. K. SELTZER,  
EMMA KELLER.