

N. F. BRENT. CAR COUPLING.

No. 458,307.

Patented Aug. 25, 1891.

Fig. 1.

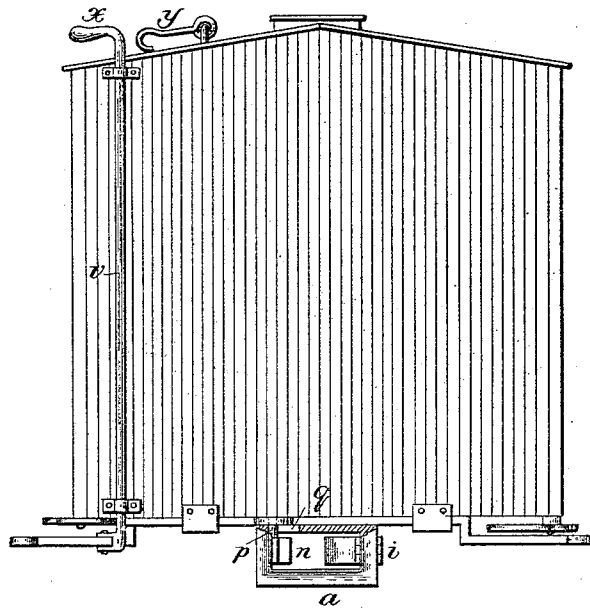
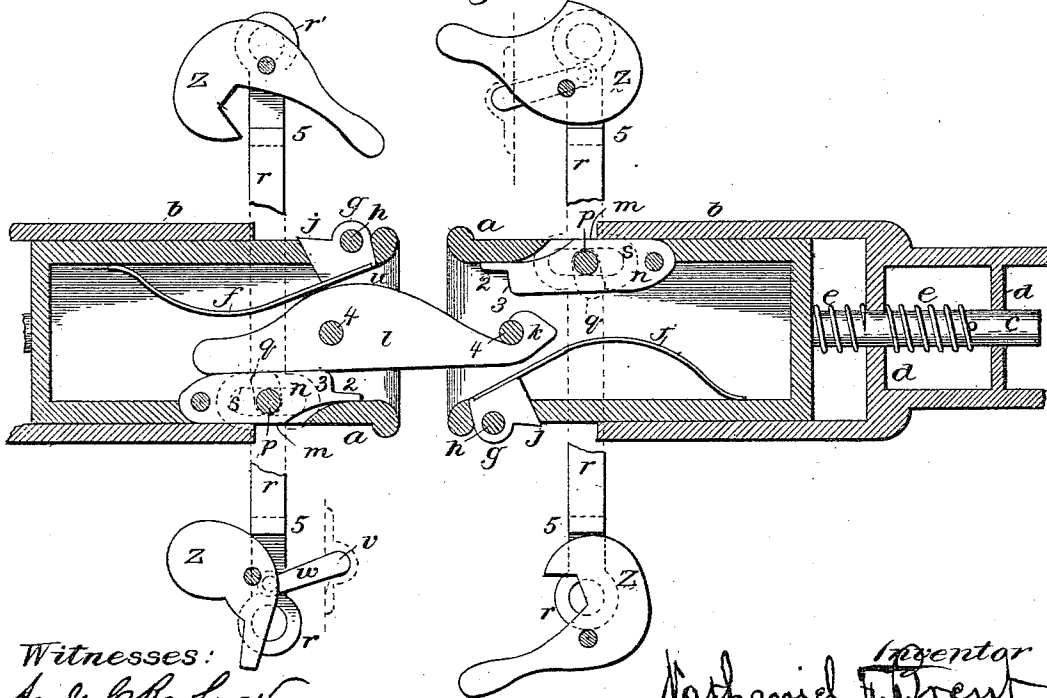

Fig. 2.



Witnesses:
Andy C. Hawley
Sowell Bette

Inventor
Nathaniel J. Brent
 By *John W. Johnson*
 Attorneys

N. F. BRENT.
CAR COUPLING.

No. 458,307.

Patented Aug. 25, 1891.

Fig. 3.

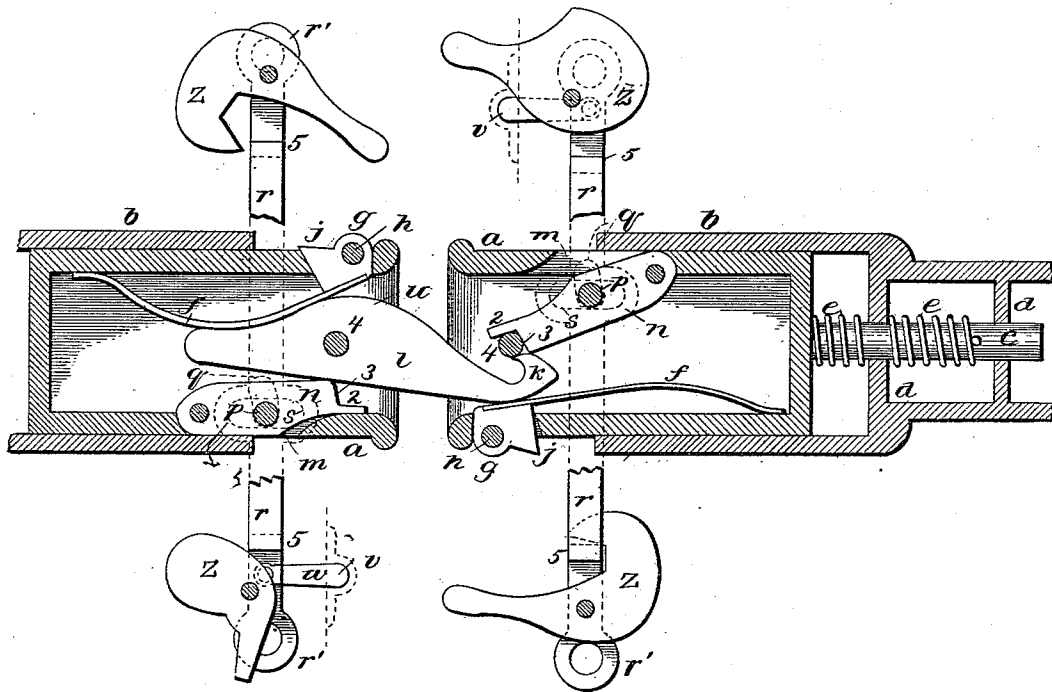

Fig. 4.

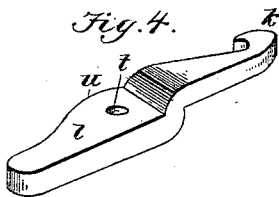
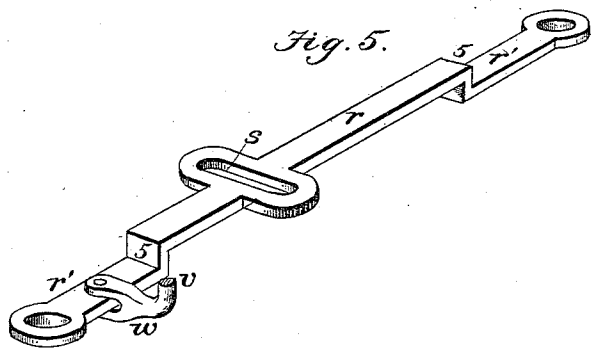

Fig. 5.



Witnesses:
Andy C. Rawlins
Howell Castle

Nathaniel F. Brent
 Inventor
John S. Johnson
 His Attorneys.

UNITED STATES PATENT OFFICE.

NATHANIEL F. BRENT, OF CHICAGO, ILLINOIS.

CAR-COUPLING.

SPECIFICATION forming part of Letters Patent No. 458,307, dated August 25, 1891.

Application filed March 17, 1891. Serial No. 385,387. (No model.)

To all whom it may concern:

Be it known that I, NATHANIEL F. BRENT, a citizen of the United States, residing at Chicago, in the county of Cook and State of Illinois, have invented new and useful Improvements in Car-Couplings, of which the following is a specification.

I have improved the car-coupling in which the coupling-link has a single hooked end, works with the usual coupling-pins, and is adapted for self-coupling freight-cars, as is shown and described in Letters Patent granted to me September 2, 1879.

My present improvement provides certain novel means whereby the cars may be uncoupled from the top or from either side of a car without removing the coupling-pins; for securing the operating devices to prevent accidental uncoupling of the cars; for holding the coupling-link in position to insure the coupling, and especially for preventing the coupling of the cars when moving them about the tracks, and without removing the coupling-pins or the coupling-link, as I will now describe, and point out in the claims concluding this specification, in connection with the accompanying drawings, in which—

Figure 1 shows an end view of a freight-car having my improved coupling and uncoupling devices applied thereto. Fig. 2 is a horizontal sectional view of the coupling devices of two cars in coupled relation, the hooked coupling-link being shown as held in secure coupled position. Fig. 3 shows a similar view, the uncoupling devices being shown in the positions they occupy to prevent the coupling action of the hook-link when such action is not desired. Fig. 4 shows the hooked coupling-link; and Fig. 5 shows the slotted slide-bar for operating the device which serves to uncouple the hooked coupling-link and also to prevent the coupling action of the said link, which is important in an automatic coupler when it is not desired to couple cars moved separately about on tracks upon which cars are standing.

Each end of each car is provided with identical draw-head coupling and uncoupling devices adapted for use with the usual coupling-pins. Each draw-head *a* is of the usual oblong square box-like casting open at the coup-

ling end for the usual pin-coupling, and preferably adapted to slide longitudinally within a guide-box *b*, firmly secured to the under side of the car-body at each end thereof. At its inner end each draw-head has a central longitudinal draw-rod *c*, fitted in cross-guides *d* in the box-casting, and provided with spiral springs *e*, placed in the casting to cushion the longitudinal movements of the draw-head in drawing the cars and in receiving the concussions thereof.

Within the draw-head at one side is fitted a flat spring *f*, which at its outer end has a solid-eyed part *g*, which stands out through a side slot to receive a pin *h*, which passes through eyes *i* on the outer side of the draw-head to hold the spring in place. This solid-eyed part *g* is fitted flush with the inner wall at the open end of the draw-head to receive the contact of the coupling-link and thereby protect the spring from being cut and worn away at this point. This solid-eyed part also forms a shoulder *j*, which stands obliquely in the wall-slot to form a stop to limit the inward movement of the spring, so as to prevent its contact with the hook end of the coupling-link *l* when the cars are coupled, and thereby prevent the spring from being cut and worn out, while at the same time its position is such as to prevent the accidental uncoupling of the hook end of the link from the coupling-pin. At the other side of the draw-head there is a wall-slot *m*, within which is pivoted a swing-plate *n*, standing forward with its free end between the inner wall of the draw-head and the coupling-pin. The free end of this swing-plate *n* terminates in a lip 2, so as to form a shoulder 3 at the end of the plate in such relation to the pin 4 that when the plate is moved inward its shouldered end 3 will strike against the hook end *k* of the coupling-link and push it to one side free of the coupling-pin and thereby allow the cars to be separated. The inner side of the swing-plate is straight, and when in the position stated its shouldered end 3 will be just behind the coupling-pin and the lip 2 of said plate will be against the side of the pin, and thus form a stop to limit the inward movement of the swing-plate to push the hook end of the link off the coupling-pin, and to one side of the

latter against the resisting force of the spring f . When the swing-plate is thus brought into action to uncouple the cars, I provide for locking it in such position to cause it to have another function, that of preventing the engagement of the hook of the coupling-link with the coupling-pin when the cars are brought together, and it is not desired to couple them, as shown in Fig. 3. In such case the coupling-link will enter the open end of the draw-head between the pin 4 and the spring f , compressing the latter, the hook end will ride upon the inner straight side of the swing-plate, and be held thereby to one side of, and so that it cannot get directly behind the coupling-pin. The swing-plate, therefore, by its form and position in the draw-head, serves both the means of uncoupling the hooked link from the coupling-pin and of preventing the hooked link from being coupled with the said pin when not desired. The placing of the swing-plate so as to stand in the line of the draw-head gives the advantage of moving it to bring its side in position to form a side wall behind the pin, and thereby prevent the hook end of the latter from catching onto the plate, because in such position of the swing-plate, the coupling-link standing out from one car, its hook end would enter the draw-head of the other, and striking the coupling-pin in the latter will press out the side spring f and ride back on the side of the swing-plate, and in moving one of the cars out from the other the hook end will move out over the side of the swing-plate free of the coupling-pin. When, however, the cars are to be coupled, the swing-plate is moved back away from the coupling-pin, as seen in Fig. 2, in which outward movement the plate is limited by the contact of its lipped end 2 against the inner wall of the draw-head.

The swing-plate is provided with a pin p , which stands up at about the middle of its length into a slot q in the upper side of the draw-head, and engages with a slide-bar r , fitted in guides on the bottom of the car just above the top of the draw-head and extending with its ends r' to each side of the car, so that it may be conveniently reached from either side and slid crosswise to move by its engagement with the pin p the swing-plate in or out, as may be desired, and for the purposes stated. For this purpose the slot q stands transversely in the top of the draw-head, and to permit of the longitudinal movement of the draw-head the slide-bar r has a slot s , which stands in the line of the draw-head, so that the latter can move with its pin p in the slot s in either position of the swing-plate and without moving the latter.

Looking at Figs. 2 and 3 it will be seen that the coupling-link has a form and construction adapted to co-operate at its non-hooked end with the spring and the swing-plate, whereby said link is held in the draw-head in position to cause its hook end to enter the draw-head

of the car to be coupled. For this purpose I make the link with a hole t in the middle of its length, by which it is secured by the coupling-pin 4 in one of the draw-heads. This coupled end of the link extends within the draw-head with its straight side against the inner straight side of the swing-plate, while the other side of the link is swelled out with a convex form u , so as to bear against the spring f , and the pin, the swing-plate, the spring, and the form of the link coact to hold the link in a straight position, so that its hook end will stand in position to enter the draw-head at one side of the coupling-pin of the car being coupled. In this construction and relation of the coupling devices the non-hooked end of the link acts as a handle within the draw-head to hold it in a fixed relation therein, and as the coupling devices of each draw-head are alike the link may be secured in either and have the relation described to the coupling and uncoupling devices.

The slide-bar, as stated, may be operated from either side of the car by its handle ends r' , to operate the swing-plate by its engaging-pin p , and I also provide for operating the slide-bar from the top of the car by means of the rod v , secured vertically on the end of the car, having a crank-arm w on its lower end pivoted to the said slide-bar, and a handle x on its upper end by which it may be turned to vibrate its crank-arm to move the slide-bar, as stated. A hook y is provided at the top of the car to lock the crank-arm when turned inward, and thereby hold the swing-plate when moved inward behind the coupling-pin when it is desired to prevent the cars from being coupled. I also provide for locking the slide-bar to hold the swing-plate either in or out of action by means of cams or hooks z , attached to the under side of the car in position to engage a shoulder or bend 5 in the bar.

Looking at Fig. 2 it will be seen that the slide-bar of one of the draw-heads is locked by the hook to secure the swing-plate against the side of the draw-head. In the other draw-head the swing-plate forms a bearing against and along the straight side of the coupling-link to hold the latter in proper position, while in Fig. 3 the swing-plate of one of the draw-heads is seen in the position in which it serves to uncouple the hook end of the link from the coupling-pin and to prevent the action of the link when it is not desired to couple the cars, and in such case the hook is seen as locking the slide-bar and its swing-plate.

I claim as my invention—

1. In a car-coupling, the combination, with the draw-head, the coupling-pin, and a hooked coupling-link, of the spring having the solid pivoted part shouldered to form a stop for the spring against the draw-head, for the purpose stated.

2. In a car-coupling, the combination, with the draw-head, the coupling-pin, the hooked

coupling-link, and the spring, of the swing-plate having the stud projecting through a slot in the top of the draw-head, and a slide-bar having a slot engaging said plate-stud, 5 for the purpose stated.

3. In a car-coupling, the combination, with the draw-head, the coupling-pin, the hooked coupling-link, and the spring, of the swing-plate pivoted at one end within the draw- 10 head and having the stud, its other end terminating in a lip and shouldered, having the relation shown to the coupling-pin, a slide-bar having a slot engaging said stud, and means for operating and securing said slide- 15 bar, in the way and for the purpose stated.

4. In a car-coupling, the combination, with the draw-head, the coupling-pin, the spring, and the swing-plate pivoted within the draw- 20 head, of the coupling-link having the hook end and the swelled and the straight sides for

co-operative relation with the said spring and the swing-plate, for the purpose stated.

5. In a car-coupling, the combination, with the draw-head, the coupling-pin, the hooked coupling-link, the spring, and the swing-plate 25 having the stud, of the slide-bar having a slot engaging said stud, a shoulder near each end, the pivoted devices engaging said shoulders, and the rod having a crank-arm engaging said slide-bar, substantially as described. 30

In testimony whereof I have hereunto set my hand in the presence of four subscribing witnesses.

NATHANIEL F. BRENT.

Witnesses:

OTTO T. LANGBEIN,
WM. KENT,
P. T. KELLY,
C. J. WARES.