

S. L. Fitts,
Making Chair-Backs,

No. 39,220,

Patented July 14, 1863.

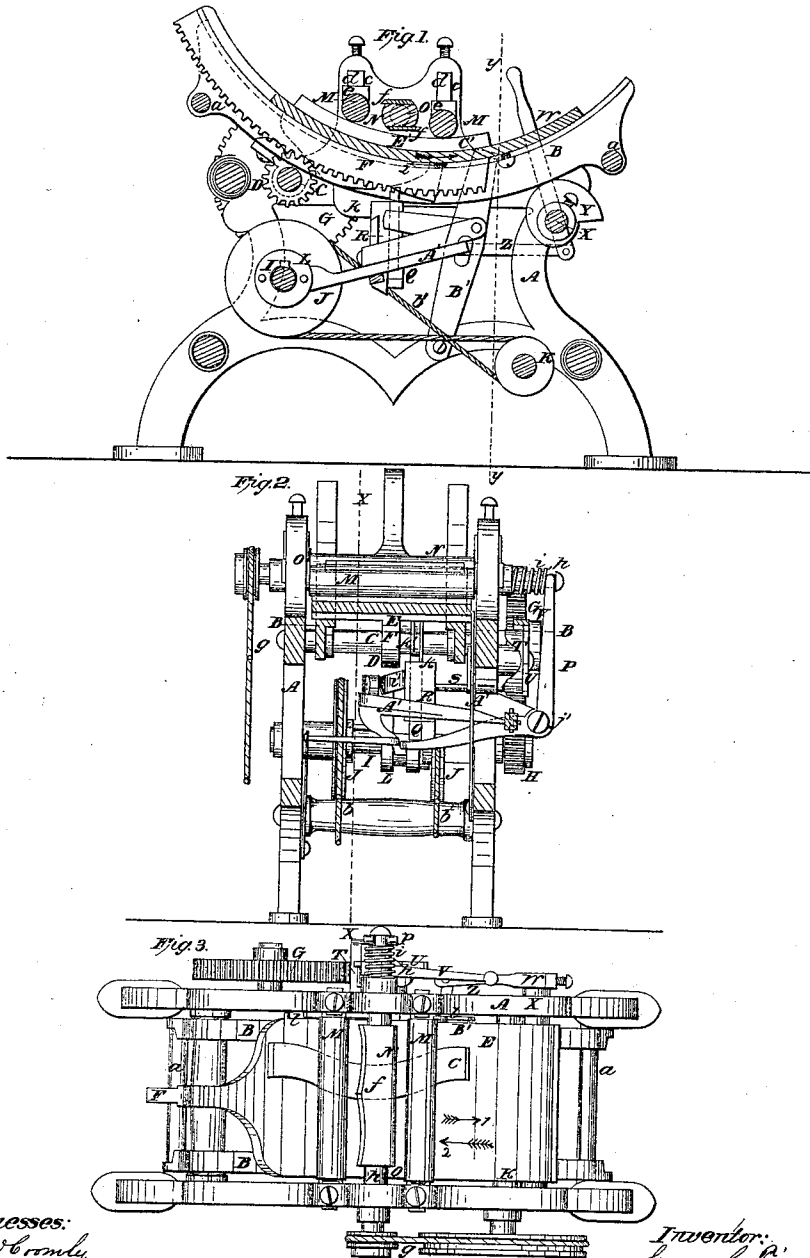

Witnesses:
J. W. C. Condy,
L. W. Reed.

Inventor:
Samuel de Fitts
per Munroe & Co
Attorneys

UNITED STATES PATENT OFFICE.

SAMUEL L. FITTS, OF ASHBURNHAM, MASSACHUSETTS.

MACHINE FOR DRESSING CHAIR-BACKS.

Specification forming part of Letters Patent No. 32,220, dated July 14, 1863.

To all whom it may concern :

Be it known that I, SAMUEL L. FITTS, of Ashburnham, in the county of Worcester and State of Massachusetts, have invented a new and Improved Machine for Dressing Chair-Backs; and I do hereby declare that the following is a full, clear, and exact description of the same, reference being had to the accompanying drawings, making a part of this specification, in which—

Figure 1 is a side sectional view of my invention, taken in the line *xx*, Fig. 2; Fig. 2, a transverse vertical section of the same, taken in the line *yy*, Fig. 1; Fig. 3, a plan or top view of the same.

Similar letters of reference indicate corresponding parts in the several figures.

This invention consists in the employment or use of a reciprocating segment bed or carriage, placed on an adjustable bed, in connection with a rotary and vibrating cutter-head and pressure-rollers, all arranged to operate as hereinafter set forth.

To enable those skilled in the art to fully understand and construct my invention, I will proceed to describe it.

A represents a framing, which may be constructed in any proper way to support the working parts, and B B represent two curved or segment ways, connected by cross-rods *a*, and fitted at one end loosely on a shaft, C, which is placed transversely in the framing A, and has a pinion, D, on it.

E is a curved or segment bed, which is placed on the ways B B, and allowed to slide freely thereon. At the under side of the bed E there is a rack, F, into which the pinion D gears. (See Fig. 1.) On one end of the shaft C there is placed a toothed wheel, G, into which a pinion, H, on a shaft, I, gears, the shaft I being in the lower part of the framing A, and having upon it two loose pulleys, J J, which are rotated by belts *b b'* from a driving-shaft, K, the belt *b'* being crossed and the belt *b* being straight, so that the pulleys J J will be rotated in reverse directions. These pulleys J J are connected alternately with the shaft I by means of a clutch, L, operated as will be presently described, and by which the direction of the rotation of the shaft C is reversed in order to give a reciprocating motion to the bed E. In the upper part of the fram-

ing A, and directly over the bed E, there are placed two pressure-rollers, M M, the journals of which are fitted in oblong slots *e*, and having springs *d* bearing upon boxes *e*, which rest on the journals of said rollers. Between the rollers M M a rotary cutter, N, is placed. This cutter is formed by having two knives, *f f*, attached to a shaft, O, which is driven by a belt, *g*, from the shaft K. The shaft O has long journals *h h*, to admit of said shaft having a certain degree of longitudinal play. One of the journals *h* has a spiral spring, *i*, upon it, and also has a groove made circumferentially in it to receive the upper forked end of a lever, P, which is of bent form and has its fulcrum at *j*. The lower horizontal part of this lever P extends underneath a pin, Q, which is fitted vertically in a socket, R, the latter being attached to a horizontal slide-rod, S, which passes through one side of the framing and is acted upon by a cam, T, which has a ratchet, U, attached to it into which a pawl, V, catches, said pawl being attached to an arm, W, on a shaft, X, which has two cams, Y Y, upon it, on which the ways B B rest. The lower end of the arm W is connected by a link, Z, with a bent lever, A', to which the clutch L is connected, and said lever A' passes through an upright lever, B', which extends up at one side of the reciprocating bed E. To the under side of the bed E there are attached two curved pendent plates, *k k'*, and to the side of the bed E, near the lever B', or adjoining it, there are placed two pins, *l*, one near each end of the bed. The chair-backs C' are got out of the proper shape and placed, one at a time, on the bed E, and underneath the rollers M M and cutter N, the rollers holding the back in proper position while the cutter N is acting upon it. The cutter acts upon the back C' when the bed E is moving in the direction indicated by the arrow 1, and when the bed has reached the termination of that movement one of the pins *l* will strike the upper end of the lever B', and actuate the bent lever A' so that the clutch will be made to shift its position on the shaft and engage with the pulley J, which will reverse the movement of the bed E. This actuating of the lever A' also moves the arm W and pawl V, the latter, through the medium of the ratchet U, turning the cam T, which slides the socket R, and brings the

pin Q under the plate *k'*, which, as the bed E moves back in the direction of arrow 2, acts upon the pin Q, and forces it down upon the lever P, so that the latter will move the cutter N longitudinally, the plate *k* having moved the cutter during the previous movement of the bed F. This longitudinal movement of the cutter N may be varied or modified to suit the character of the work required. The spring I gives the return movement to the cutter, and a spring, *i'*, gives the return movement to the socket R. At the termination of the movement of the bed E, in the direction indicated by the arrow 1, the shaft X is turned by the movement of the arm W and the cams Y Y let down the ways B B, so that the cutter will not act upon the back C' during the back movement of the bed F, each back being operated upon during two forward movements of the bed E. The arrangement as a whole is extremely simple and efficient. The bed E is varied during the termination of its backward

movement by the proper pin *l* coming in contact with the upper end of the lever B'.

Having thus described my invention, what I claim as new, and desire to secure by Letters Patent, is—

1. The reciprocating segment-bed E, placed on the adjustable ways B B, and operated substantially as shown, in combination with the pressure-rollers M M and the rotary cutter N, all arranged as and for the purpose specified.

2. The arrangement and combination of the shaft X, provided with the cams Y Y, the arm W, pawl V, ratchet U, the levers P A', cam T, socket R, with pin Q, the spring *i* on the journal of the cutter N, and pins *l l* at the side of bed E, all arranged as and for the purpose herein set forth.

SAMUEL L. FITTS.

Witnesses:

WILLIAM P. ELLIS,
OHIO WILITNEY, JR.