

J. H. Truex,

2. Sheets, Sheet 1.

Flagpole Scale.

No. 110696.

Patented Jan. 3, 1891.

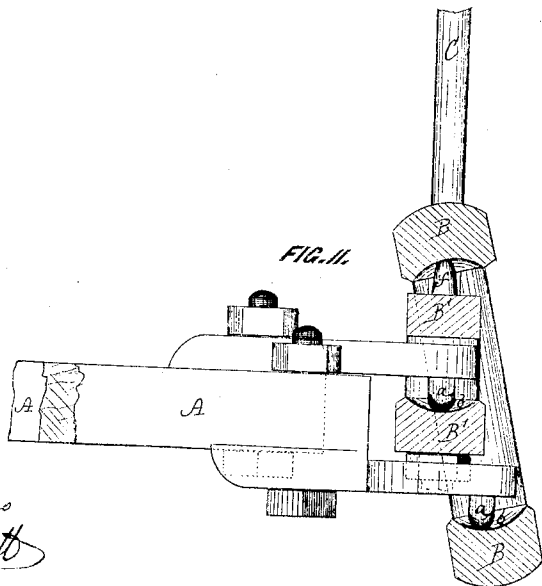
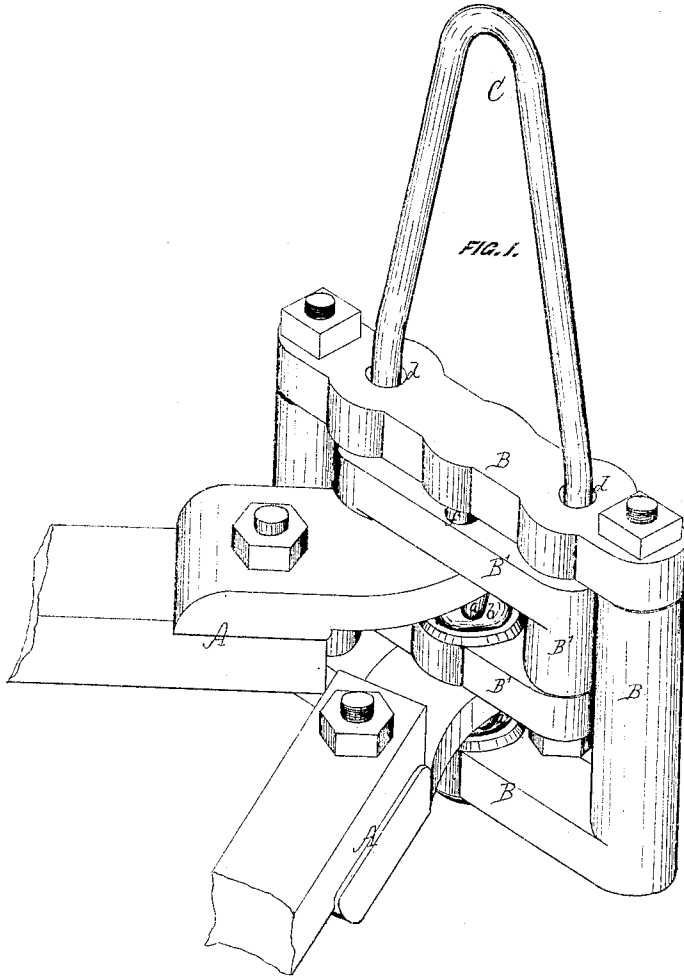

Witnesses
E. Barnes
G. W. Miatt

J. H. Truex
By J. Fraser & Co.
attys

J. H. Trues,

2, Sheets, Sheet 2.

Platform Scale.

No. 110,696.

Patented Jan. 3, 1871.

FIG. III.

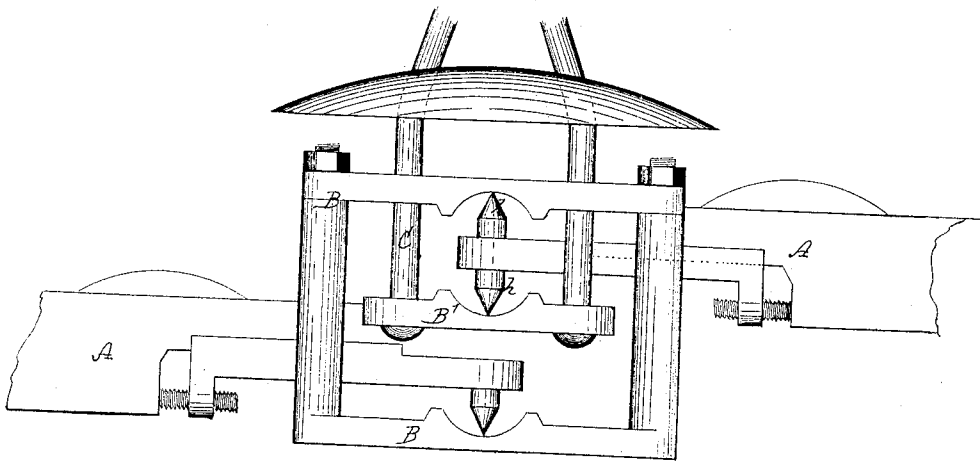

Witnesses.

J. P. Barnes
Wm. M. Meath

J. H. Trues
By J. F. Frazee
attys

United States Patent Office.

JOHN H. TRUEX, OF ROCHESTER, NEW YORK.

Letters Patent No. 110,696, dated January 3, 1871.

IMPROVEMENT IN PLATFORM-SCALES.

The Schedule referred to in these Letters Patent and making part of the same.

To all whom it may concern :

Be it known that I, JOHN H. TRUEX, of the city of Rochester, in the county of Monroe and State of New York, have invented a certain new and useful Improvement in Platform-Scales, of which the following is a specification.

Nature of the Invention.

This invention is similar in principle to the patent of Thaddeus Fairbanks, December 20, 1859, but embodies an improved construction and arrangement of the parts, whereby the levers and their stirrups have a free and independent action.

General Description.

In the drawing—

Figure 1 is a perspective view of my improvement.

Figure 2, a vertical cross-section of the same, showing the free and independent action of the levers and their stirrups.

Figure 3, a view of Fairbanks' scale.

A A represent the levers;

B B', the stirrups; and

C represents the loop by which the parts are suspended.

The levers are of the kind ordinarily used, and at their outer or diverging ends are attached to the opposite corners of the platform.

At their inner or converging ends they have bearing-points *a a*, which rest respectively in bearings *b b* in the bottom bars of the stirrups.

The stirrups are simply rectangular frames, resting one within the other, and being entirely free, and having no connection one with the other, except the passage of the sides of the loop C, through the holes *d d* of the outer one.

These holes are made somewhat larger than the sides of the loop, so as to allow a free action of the inner in the outer stirrup.

The top bar of the inner stirrup also has a bearing-point, *f*, upon which rests and is suspended the outer stirrup.

The advantage of this construction is as follows:

Each lever and its stirrup has a free action, so that it can swing outward or inward independently of the other, as shown by the outline in fig. 2. In other words, as the outer stirrup is simply hung upon the bearing-point *f*, and as its lever, resting upon its lower bar, is entirely free of any attachment to or connection with the other stirrup and lever, said parts can be thrown out or in without, in any manner, affecting the other parts.

This action is very necessary, since it is frequently

the case that heavy weights are dropped heavily upon one side or the other of the platform, which gives a sudden impetus and causes binding and rigidity unless some provision is made to relieve it. In this arrangement, the independent action of each set of levers and stirrups, obviates all difficulty of the kind.

In Fairbanks' scale this effect cannot be accomplished, since the upper bar of the outer stirrup, and the lower bar of the inner stirrup, both bear and bind upon the double points *h h* of the upper lever, which are thus confined between them.

It will be seen that if either this or the lower lever receives an end motion, it must impart the same motion to both stirrups, instead of one, and consequently to the other lever. Therefore, both sets of levers and stirrups are practically bound together, which renders them stiff and rigid in action, and not so effective in use.

In addition to the above, there is an essential difference in the construction of the two devices, since in mine two rectangular frames of complete form are used, one situated within the other, while in Fairbanks but one frame is used, with a bar attached to the loop inside to form the inner one.

I am aware that stirrups have been suspended one within the other, but they are only set one upon the other on the pivots, and are not connected together, which renders the scales liable to be thrown down by any jar or sudden movement.

In my invention the liability to such accidents is avoided by the stirrups being loosely held together by the continuation of the loop C, which passes through the upper plate of the outside stirrup, and through the sides of the inner stirrup, and is secured by a suitable nut.

Claim.

What I claim, and desire to secure by Letters Patent, is—

The arrangement of the two stirrups B B', one inside of the other, the outer suspended on the inner, both being loosely attached to each other by the continuation of the loop C, which prevents their being detached by accident, with the levers A A resting upon their respective stirrups independently of any connection with the other, whereby a free action of each set is obtained with a secure construction of mechanism, as herein shown and described.

J. H. TRUEX.

Witnesses:

R. F. OSGOOD,

G. WILLEM. MIATT.