

(12) STANDARD PATENT
(19) AUSTRALIAN PATENT OFFICE

(11) Application No. **AU 2008299528 B2**

(54) Title
Control of by-pass current in multi-polar light metal reduction cells

(51) International Patent Classification(s)
C25C 3/00 (2006.01) **C25C 3/06** (2006.01)
C25C 3/02 (2006.01) **C25C 3/08** (2006.01)
C25C 3/04 (2006.01)

(21) Application No: **2008299528** (22) Date of Filing: **2008.09.03**

(87) WIPO No: **WO09/033260**

(30) Priority Data

(31) Number (32) Date (33) Country
60/972,463 **2007.09.14** **US**

(43) Publication Date: **2009.03.19**

(44) Accepted Journal Date: **2012.02.16**

(71) Applicant(s)
Alcan International Limited

(72) Inventor(s)
Creber, David K.;Gesing, Adam J.

(74) Agent / Attorney
Shelston IP, Level 21 60 Margaret Street, Sydney, NSW, 2000

(56) Related Art
CA 1228051 A1
CA 1337059 C
CA 1224743 A1
CA 2409395 A1

(19) World Intellectual Property Organization
International Bureau



(43) International Publication Date
19 March 2009 (19.03.2009)

PCT

(10) International Publication Number
WO 2009/033260 A1

(51) International Patent Classification:

C25C 3/00 (2006.01) C25C 3/06 (2006.01)
C25C 3/02 (2006.01) C25C 3/08 (2006.01)
C25C 3/04 (2006.01)

[CA/CA]; 13160 Amanda Court, Windsor, Ontario N8N 4J1 (CA). CREBER, David K. [CA/CA]; 55 Riverside Drive, Kingston, Ontario K7L 4V1 (CA).

(21) International Application Number:

PCT/CA2008/001544

(74) Agents: GALE, Edwin J. et al.; Kirby Eades Gale Baker, Box 3432, Station D, Ottawa, Ontario K1P 6N9 (CA).

(22) International Filing Date:

3 September 2008 (03.09.2008)

(81) Designated States (unless otherwise indicated, for every kind of national protection available): AE, AG, AL, AM, AO, AT, AU, AZ, BA, BB, BG, BH, BR, BW, BY, BZ, CA, CH, CN, CO, CR, CU, CZ, DE, DK, DM, DO, DZ, EC, EE, EG, ES, FI, GB, GD, GE, GH, GM, GT, HN, HR, HU, ID, IL, IN, IS, JP, KE, KG, KM, KN, KP, KR, KZ, LA, LC, LK, LR, LS, LT, LU, LY, MA, MD, ME, MG, MK, MN, MW, MX, MY, MZ, NA, NG, NI, NO, NZ, OM, PG, PH, PL, PT, RO, RS, RU, SC, SD, SE, SG, SK, SL, SM, ST, SV, SY, TJ, TM, TN, TR, TT, TZ, UA, UG, US, UZ, VC, VN, ZA, ZM, ZW.

(25) Filing Language:

English

(26) Publication Language:

English

(30) Priority Data:

60/972,463 14 September 2007 (14.09.2007) US

(71) Applicant (for all designated States except US): ALCAN INTERNATIONAL LIMITED [CA/CA]; 1188 Sherbrooke Street West, Montreal, Québec H3A 3G2 (CA).

(84) Designated States (unless otherwise indicated, for every kind of regional protection available): ARIPO (BW, GH, GM, KE, LS, MW, MZ, NA, SD, SL, SZ, TZ, UG, ZM, ZW), Eurasian (AM, AZ, BY, KG, KZ, MD, RU, TJ, TM), European (AT, BE, BG, CH, CY, CZ, DE, DK, EE, ES, FI,

(72) Inventors; and

(75) Inventors/Applicants (for US only): GESING, Adam J.

[Continued on next page]

(54) Title: CONTROL OF BY-PASS CURRENT IN MULTI-POLAR LIGHT METAL REDUCTION CELLS

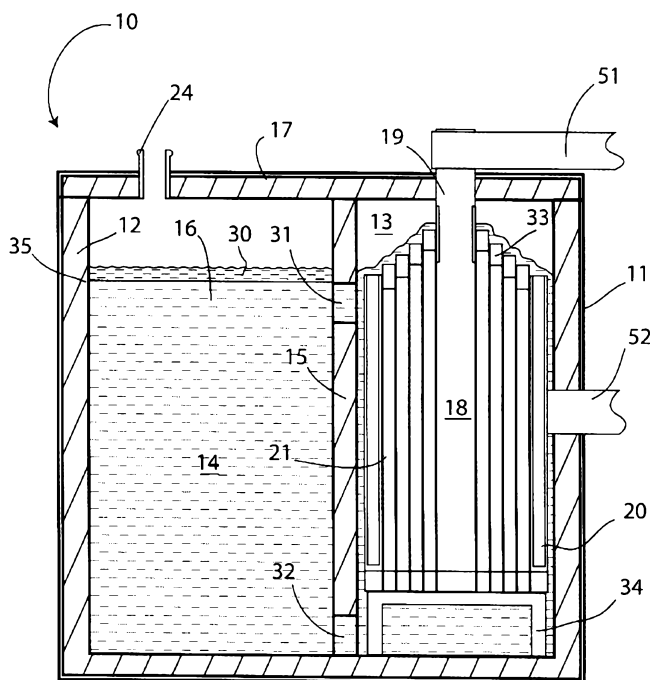

Fig. 5

(57) Abstract: The invention relates to a multi-polar reduction cell for production of a light metal by electrolysis. The cell has an anode, a cathode, and at least one current-conducting multi-polar electrode interposed between the anode and the cathode. The cell has a molten electrolyte containing a metal salt to be electrolyzed held within the cell and preferably has means to maintain an upper surface of the electrolyte at a predetermined level within the cell. The level is preferably maintained above the upper end of the multi-polar electrode(s), at least in use of the cell. The multi-polar electrode has an electrically insulating surface at its upper end that minimizes or eliminates by-pass current between the anode and cathode when the cell is operated. The invention also relates to the method of minimizing or eliminating the by-pass current.

WO 2009/033260 A1



FR, GB, GR, HR, HU, IE, IS, IT, LT, LU, LV, MC, MT, NL,
NO, PL, PT, RO, SE, SI, SK, TR), OAPI (BF, BJ, CF, CG,
CI, CM, GA, GN, GQ, GW, ML, MR, NE, SN, TD, TG).

- *as to the applicant's entitlement to claim the priority of the earlier application (Rule 4.17(iii))*
- *of inventorship (Rule 4.17(iv))*

Declarations under Rule 4.17:

- *as to applicant's entitlement to apply for and be granted a patent (Rule 4.17(ii))*

Published:

- *with international search report*

CONTROL OF BY-PASS CURRENT IN
MULTI-POLAR LIGHT METAL REDUCTION CELLS

TECHNICAL FIELD

5 This invention relates to the control of by-pass current in multi-polar metal reduction cells, particularly those used for the production of light metal such as magnesium, aluminum, sodium, lithium, etc.

BACKGROUND ART

10 Magnesium and other light metals are often produced by electrolysis from metal salts in mono-polar electrolysis cells. However, multi-polar electrolysis cells may be used, where such cells have at least one, and usually several, multi-polar electrodes positioned in the space between an anode and a cathode forming a series connection of sub-cells. The multi-polar electrodes increase the number of
15 electrolysis steps at which electrolysis may take place, and thus increase the cell energy and production efficiency compared to mono-polar cells of the same amperage. A gas is normally generated in the electrolyte during the process of electrolysis (for example, chlorine is generated when magnesium is derived from magnesium chloride). In a vertical electrode cell, the resulting gas bubbles rise
20 between the electrodes, lifting the surrounding electrolyte with them. This causes fresh electrolyte to flow between the electrodes from below and ensures that fresh metal salt is made available for further reduction. The rising volume of gas and electrolyte emerges from between the electrodes at the top of the cell and the gas separates from the liquid to fill the head space above the electrodes. The
25 electrolyte circulates back to a reservoir of electrolyte in the cell for replenishment of salt feed and eventual recirculation to the space between electrodes. Cells of this kind are said to operate on the "gas-lift" principal.

Multi-polar electrolysis cells that employ the gas-lift principal may be of two main kinds. In a first kind of cell, the anode, cathode and multi-polar electrodes are
30 planar and are arranged face-to-face in a row with suitable gaps therebetween. In a second kind of cell, the anode is in the form of a solid upright rod and the cathode

and multi-polar electrodes are in the form of hollow cylinders of different diameters encircling the rod at increasing distances, the cathode being the most distant from the anode rod. In both cases, the electrodes are encased in a container lined with refractory material that provides thermal insulation for the molten electrolyte and
5 the molten metal. An arrangement for the collection and removal of generated gas is also provided at the upper end of the cell.

A persistent problem with cells of this kind is that bypass current travels around the ends of the multi-polar electrodes following a more direct path through the electrolyte between the cathode and the anode rather than passing between
10 the multi-polar electrodes through the series-connected sub-cells formed between adjacent electrodes. This leads to reduced cell productivity, increased power consumption and decreased current efficiency. The by-pass current may typically reduce current efficiency by 3 to 5% or more.

A by-pass current forms most readily at the upper end of the electrodes if
15 the electrolyte overflows the electrodes driven by the rising volume of gas. In some cell designs, the by-pass current has been kept in check by designing the electrode cassettes (i.e. electrode assemblies) in such a way that the thickness of the electrolyte layer passing over the tops of the electrodes is minimized. This requires careful electrolyte level control to ensure that adequate, but not excessive, flow is
20 maintained. Despite such measures, by-pass currents still flow and there is a reduction of current efficiency. Examples of prior patents in which level control is suggested to reduce the by-pass current are U.S. patent 4,514,269 which issued on April 30, 1985 to Sivilotti, and U.S. patent 5,935,394 which issued on August 10, 1999 to Sivilotti et al. (and which are both assigned to the same assignee as the
25 present application). Other solutions have included the provision of electrode extensions on the upper end of the multi-polar electrodes. These extensions project well above the surface of the electrolyte and thus prevent overflow of the electrolyte. However, this solution requires that the electrolyte rising in the inter-electrode gaps be diverted, generally to the ends of the electrode array where
30 channels are provided to return the electrolyte to the reservoir. This reduces the efficiency of the electrolyte recirculation and it is a solution that cannot be

employed with cylindrical electrodes, as there are then no exits for electrolyte flow except over the tops of the electrodes. Examples of prior patents in which electrode extensions are suggested are U.S. Patent 4,401,543 which issued on August 30, 1983 to Ishizuka, and Japanese Patent Application 02-258993A which published on October 19, 1990.

5 It is an object of the present invention to overcome or ameliorate at least one of the disadvantages of the prior art, or to provide a useful alternative.

Any discussion of the prior art throughout the specification should in no way be considered as an admission that such prior art is widely known or forms part of common general knowledge in the field.

10

SUMMARY OF THE INVENTION

According to a first aspect, the present invention provides a multi-polar electrolytic cell for producing a light metal by electrolysis of a corresponding metal salt, the cell comprising:

15 a molten electrolyte containing a metal salt that produces a light metal and a gas when electrolyzed; and

an arrangement of generally vertical electrodes surrounded by said molten electrolyte, including an anode, a cathode and at least one current-conducting multi-polar electrode interposed between the anode and the cathode, said at least one multi-polar
20 electrode having an upper end;

wherein said at least one multi-polar electrode has an electrical insulator positioned to extend at least partially over said upper end, and wherein, in use of said cell, said insulator is immersed beneath said electrolyte.

25 According to a second aspect, the present invention provides a method of minimizing or eliminating by-pass current between an anode and a cathode in a multi-polar electrolysis cell suitable for production of a light metal, said method comprising:

electrically insulating an upper end of at least one multi-polar electrode of said cell,
and

30 conducting electrolysis with said insulated upper end maintained below an upper surface of molten electrolyte containing a metal salt to be electrolyzed held within said cell.

According to a third aspect, the present invention provides a multi-polar electrolytic cell for producing a light metal by electrolysis of a corresponding metal salt, the cell comprising:

35 a molten electrolyte containing a metal salt that produces a light metal and a gas when electrolyzed; and

an arrangement of generally vertical electrodes surrounded by said molten electrolyte, including an anode, a cathode and a current-conducting multi-polar electrode interposed between the anode and the cathode, said multi-polar electrode having an upper end and an electrical insulator positioned to extend over said upper end;

5 wherein, in use of said cell, said insulator is immersed beneath said electrolyte.

Unless the context clearly requires otherwise, throughout the description and the claims, the words "comprise", "comprising", and the like are to be construed in an inclusive sense as opposed to an exclusive or exhaustive sense; that is to say, in the sense of "including, but not limited to".

10 Certain exemplary embodiments can provide a multi-polar electrolytic cell for producing a light metal by electrolysis of a corresponding metal salt. The cell comprises a molten electrolyte containing a metal salt that produces a light metal and a gas when electrolyzed, and an arrangement of generally vertical electrodes surrounded by the molten electrolyte, including an anode, a cathode and at least one current-conducting multi-polar
15 electrode interposed between the anode and the cathode. At least one of the multi-polar electrode(s) has an upper end with an electrical insulator positioned over the upper end (at least partially covering the upper end surface of the electrode). In use of the cell, the insulator(s) is (are) immersed beneath the electrolyte as it overflows the electrodes. The cell may minimize or eliminate by-pass current normally encountered in multi-polar
20 electrolysis cells.

Cells of this kind preferably lack outlets or channels for the rising electrolyte that would permit the electrolyte to be diverted around and prevented from rising over the upper ends of the electrodes. Thus, the electrode structure (whether planar or cylindrical) is preferably such that all or substantially all of the rising electrolyte passes over the insulated
25 upper ends of the multi-polar electrode(s), as well as the cathode, during normal operation of the cell. Thus, the cells are preferably of a kind that, but for the insulation of the upper ends of the electrodes as disclosed herein, would develop a significant by-pass current during use.

Other exemplary embodiments can provide a method of minimizing or eliminating
30 by-pass current between an anode and a cathode in a multi-polar

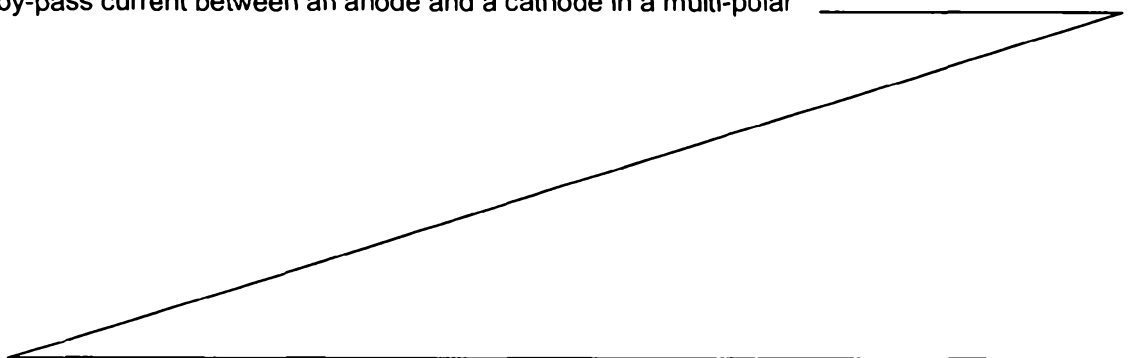

electrolysis cell suitable for production of a light metal, the method comprising electrically insulating an upper end of at least one multi-polar electrode of the cell, and conducting electrolysis with the insulated upper end maintained below an upper surface of molten electrolyte containing a metal salt to be electrolyzed held
5 within the cell.

By the term "by-pass current" we mean current that flows around (above, below and beside) a multi-polar electrode resulting in a skipping of at least one multi-polar electrolysis step between electrodes (anode, cathode or multi-polar electrode) without contributing to the electrolysis reaction. It is sometimes referred
10 to as current leakage and it represents a loss of current efficiency of the cell.

By the term "immersed beneath" to describe the condition of the insulators at the upper ends of the electrodes during normal use of the cell, we mean that the insulators are covered by electrolyte either by virtue of the overflow of the rising electrolyte and/or by virtue of the insulators being positioned below the upper level
15 of the electrolyte that it adopts when current is not flowing through the cell. In the former case, the upper ends of the electrodes, or at least the insulators, may stand proud of the upper level of the electrolyte when no current is flowing. In the latter case, they may be immersed.

In certain embodiments, it is advantageous to electrically insulate part of the
20 anode as well. Such insulation may be placed on the face of the anode (or surrounding a cylindrical anode). The insulation can be effective even if it is entirely below the electrolyte surface, but it is particularly preferred that it extend above the electrolyte surface. This insulation minimizes further the bypass currents that would flow from the anode across the adjacent multi-polar electrode even when
25 the multi-polar electrode has an insulator present.

The anode and multi-polar electrodes used in the present invention may be made of graphite, metals, cermets, composites, and laminates of these materials. The cathode is generally made of steel. The electrodes are generally non-consumable in that the electrode is not consumed by the main electrolysis reaction.
30 However, side reactions may contribute to some deterioration of the electrode material. The electrical insulators should preferably be stable in the cell

environment and resistant to attack or degradation by electrolyte and the products of electrolysis at the cell operating temperature for the duration of the cell life.

When magnesium is the metal being produced, alumina is the preferred material for the insulators. Other materials may alternatively be employed, e.g. magnesia, Mg-
5 aluminate spinel, aluminum nitride, silicon nitride, SIALON (a fine grain non-porous technical grade engineering material comprising a silicon nitride ceramic with a small percentage of aluminum oxide added), etc. The insulator may be a solid sintered or fused-cast ceramic block keyed into the edge of the graphite electrode or held in place by ceramic spacers. Alternatively, the insulators may comprise a
10 coating layer applied to the appropriately shaped electrode edge by a ceramic coating process, such as plasma spraying, sputter deposition and chemical vapour deposition. Still another electrode edge insulator may comprise thin ceramic tiles adhesively bonded to the electrode by cement.

One way of providing the upper ends of the multi-polar electrodes with
15 electrically insulating surfaces is to add pieces of insulating refractory material to the upper ends of the electrically conductive parts of the electrodes.

BRIEF DESCRIPTION OF THE DRAWINGS

Fig. 1 is plan view of a multi-polar electrolysis cell with the top removed
20 suitable for use with the present invention, the cell containing a cassette of electrodes of upright planar shape;

Fig. 2 is a plan view of a multi-polar electrolysis cell with the top removed suitable for use with the present invention, the cell containing a plurality of cassettes or electrodes of upright cylindrical shape;

25 Fig. 3 is a vertical cross-section of an electrode cassette along the line A-A in either Fig. 1 or Fig. 2 in which the multi-polar electrodes (either planar or cylindrical) are insulated in accordance with one preferred form of the present invention;

Fig. 4 is a vertical cross-section of an electrode cassette along the line A-A on
either Fig. 1 or Fig. 2 in which the multi-polar electrodes (either planar or cylindrical)
30 are insulated in accordance with a preferred form of the present invention, but with the upper ends at different heights;

Fig. 5 is a vertical cross-section of an electrolysis cell provided with one or more cylindrical cassettes of the kind shown in Fig. 4;

Figs. 6A to 6G illustrate various ways in which insulating material may be fixed to the electrically-conductive material of electrodes;

5 Fig. 7A is a partial perspective view of an alternative design of insulating block suitable for insulating upper ends of planar or electrodes;

Fig. 7B is a partial perspective view of an alternative design of insulating block suitable for insulating upper ends of cylindrical electrodes;

Fig. 8 is a graph showing the variation of by-pass currents in one example of
10 a cell with insulators of various heights on the tops of the multi-polar electrodes;
and

Fig. 9 is a graph of the measured current efficiency of a cell using insulators on the tops of some multi-polar electrodes relative to a cell without insulators over an extended period of cell operation.

15 DETAILED DESCRIPTION OF THE EXEMPLARY EMBODIMENTS

The present invention is capable of being used with multi-polar cells of all kinds, but mainly multi-polar cells that have vertical (or sloping) electrodes that are planar or cylindrical. However, the exemplary embodiments relate in particular to such cells in which electrolyte circulation is achieved by use of a "gas-lift" principal
20 in which a gas generated during electrolysis over the entire active surfaces of the electrodes causes upward flow of electrolyte in the inter-electrode gaps. When the electrolyte reaches the tops of the gaps, it overflows the adjacent tops of the electrodes (the multi-polar electrodes and cathode) and returns to the body of the cell. In the cells utilized for the exemplary embodiments, normally no channels are
25 provided to divert the electrolyte and to avoid such overflow. The indicated flow of electrolyte allows for efficiency of electrolyte circulation, but permits communication between electrodes and hence the possibility of the development of bypass current. A good circulation in the cell is needed to keep the inter-electrode gaps supplied with fresh salt to be electrolyzed, permit efficient removal
30 of the anode gas which is generated and collection of the metal cathode product

and thus allow productivity to be maintained. It is therefore desired to reduce bypass current (current efficiency loss) without reducing the efficiency of circulation.

Figures 1 and 2 are simplified plan views of electrolysis cells 10 each with a top wall removed. The cell of Fig. 1 has an electrode cassette made up of planar electrodes, whereas the cell of Fig. 2 has several electrode cassettes made up of cylindrical electrodes. In each case, the cell 10 includes an outer wall 11 provided with a refractory lining 12 that provides insulation against heat loss and flow of electricity. The cell is divided into an electrode compartment 13 and a reservoir compartment 14 separated from each other by a vertical refractory wall 15. The compartments 13 and 14 communicate with each other via channels (not shown in these figures, but shown later in relation to Fig. 5) provided near the top and bottom of the wall 15. This allows molten electrolyte 16 to circulate freely between the two compartments. Fresh metal salt may be added to the electrolyte in reservoir compartment 14 from time to time to replenish the salt consumed during the process of electrolysis.

The electrode compartment 13 of Fig. 1 contains an arrangement of electrodes in the form of an electrode cassette 18 made up of a vertical planar anode 19 flanked on each side at a distance by a pair of vertical planar cathodes 20. Interposed between the anode and the cathodes are eight vertical planar multi-polar electrodes 21, four on one side of the anode and four on the other side of the anode.

Vertical ends 22 and 23 of the cassette 18 are closed by ceramic insulators made up of a ceramic anode side insulator 25, ceramic cathode side insulators 26, ceramic side edge insulators 27 and ceramic spacers 28. These ceramic insulators and spacers prevent the development of bypass current at the vertical side edges 22 and 23 of the electrode cassette 18. They also prevent movement of electrolyte 16 into or out of the cassette 18 at the side edges 22 and 23 so the flow of electrolyte is kept vertical. In some embodiments, it is convenient if these insulators are made part of the adjacent outer wall 11, 12 and the vertical refractory wall 15. The electrode cassette 18 is positioned between short vertical refractory walls 24.

The electrode compartment of Figure 2 contains a plurality of cylindrical electrode assemblies or cassettes 18 made up of an outer cylindrical cathode 20, an inner rod-like cylindrical anode 19, and four multi-polar electrodes 21 in between the cathode and anode. The electrodes are nested together in the manner shown.

5 Figure 3 is a vertical cross-section through an electrode cassette 18 along line A-A in either Figure 1 or in Figure 2 as these cross-sections of both figures look essentially the same. In Figure 3, the cassette 18 of electrodes is made up of the anode 19 (which may be planar as in Figure 1 or a circular rod as in Figure 2) and the cathode 20 (again either planar or cylindrical). The gap between the anode and the
10 cathode on each side is filled by four different spaced multi-polar electrodes 21 (the embodiment of Fig. 1) or different parts of the four cylindrical multi-polar electrodes (the embodiment of Fig. 2) separated by gaps 36. In this view, it can be seen that the upper ends 29 of the multi-polar electrodes 21 are capped by insulators 33 which are blocks made of an electrically-insulating refractory material.
15 The method of attachment of the blocks to the electrodes is discussed in detail later.

Referring again to Figure 3, the anode 19 rests on a ceramic spacer block 40 that in turn rests on the floor of the cell or more preferably on a support within the cell (not shown in this view). Similarly, the cathode 20 rests on a refractory ceramic spacer 41 and the multi-polar electrodes 21 rest on aligned ceramic refractory
20 spacer blocks 42 which rest on a support within the cell (not shown). The blocks 40, 41 and 42 are provided with gaps 43 that align with the gaps 36 between the electrodes so that electrolyte may enter the cassette 18 of electrodes from below. In the embodiment of Figure 3, the anode 19 is also provided with a ceramic refractory circumferential insert 45 on its exterior surface in the region confronting
25 the upper ends of the multi-polar electrodes and the insulators 33. This insert provides an insulating refractory shield that further minimizes the risk of bypass current.

In operation, the cassettes 18 as shown in Figure 3 are immersed in the electrolyte 16 of the cell such that the tops of the insulators 33 are, at least in use,
30 positioned below the surface of the electrolyte 16. The gas generated in the gaps 36 between the anode, cathode and multi-polar electrodes causes electrolyte (now

containing droplets of metal resulting from the electrolysis) to flow upwards, and to form a layer 50 of electrolyte on the top of the electrodes which flows outwardly in a transverse manner to the openings or channels around the cassette. The electrolyte then flows into the electrode compartment 13 (Fig. 1 and Fig. 2) and via 5 openings previously mentioned in the upper portion of the separating vertical refractory wall 15 to the reservoir compartment 14 where metal separation occurs. The electrolyte then returns via openings in the lower portion of the vertical refractory wall 15 to the underside of the electrode cassette where it re-enters the inter-electrode gaps 36 via the gaps 43 provided between the supports 40, 41 and 10 42.

Figure 4 shows an alternative embodiment having cylindrical electrode cassettes 18 in which the electrodes are configured as in Figure 3, except that the upper ends of the insulators 33 on the top of the multi-polar electrodes 21 are arranged in a stepwise manner of increasing height towards the anode 19. Such a 15 cassette can be operated with the electrodes immersed well below the surface of the electrolyte, but can also be advantageously operated with the electrolyte level controlled so that the electrolyte containing the metal droplets cascades over the tops to achieve a relatively thin layer of electrolyte as shown at 50. This type of stepped arrangement is shown for cassettes without insulators on the top of the 20 electrodes in U.S. Patent 5,935,394 (the disclosure of which is incorporated herein by reference). Such a stepped arrangement has been used to reduce the bypass currents with some effectiveness, but the addition of insulators adds a still further significant reduction of bypass currents in arrangements of this kind.

Figure 5 shows a vertical cross-section of a cell 10 similar to that of Figure 2 25 but provided with at least one electrode cassette 18 of the type shown in Figure 4. The cell 10 comprises a vessel provided with outer walls 11 having a refractory and insulating lining 12. The vessel has a lined cover 17 that is sealed against gas leaks from the cell but has a gas vent 24 which may be connected to a conduit (not shown) for gas delivery to other equipment. The electrode cassette 18 is connected 30 to a current source (not shown) by an anode busbar 51 at the top of the anode 19 and by a cathode busbar 52 welded to the cathode 20 of the electrode cassette 18,

and passing through the wall 11 of the cell, where it is sealed against electrolyte leakage.

The cell is divided by vertical refractory wall 15 into an electrode compartment 13 occupied by the electrode cassette or cassettes 18, and reservoir compartment 14 where metal collection takes place. The vertical refractory wall 15 is provided with an upper opening 31 and lower opening 32 (or more than one of such openings). The bottom of each electrode cassette 18 is supported above the floor of the electrode compartment 13 by refractory supports 34. These supports are sufficiently open that they do not impede the flow of electrolyte to and within the cassette.

The cell is filled with molten electrolyte 16 to a level 35 in the reservoir compartment 14. During operation, the electrolyte flows upwards between the electrodes in the electrode cassette 18, flows over the tops of the insulators 33 to the electrode compartment 13, and into the reservoir compartment via the opening 31. The molten metal is entrained as droplets in the electrolyte stream and the droplets float to the surface in the reservoir compartment, where they coalesce to form a floating layer 30. The electrolyte eventually flows back to the electrode compartment 13 via the lower opening 32. Metal is periodically removed by vacuum tapping via an opening (not shown) in the top cover 17. The cover 17 may also have a closable opening (not shown) for the introduction of metal salt into the cell from time to time.

Means (not shown) are also preferably provided to maintain the upper level of the electrolyte 16 at a predetermined level 35 in the cell. Such means are known in the prior art, for example in U.S. Patent 4,518,475 (the disclosure of which is incorporated herein by reference). In the embodiments where the electrolyte level is set so that the tops of the insulators are fully immersed in the electrolyte at all times, the control of the electrolyte level is less critical.

In all embodiments, the insulators 33 are preferably positively secured to the electrodes 21 to prevent their dislodgment during operation of the cell. Depending on the material used for the insulators, they may experience buoyancy when submerged in the electrolyte, so there is therefore usually a need to attach the

insulators by means other than gravity alone. The electrical insulation helps to prevent the development of bypass current between the anode and the cathode. The insulators 33 effectively provide the multi-polar electrodes with electrical insulation extending completely along the top edges 29 of the electrodes.

5 Figures 6A through 6G illustrate some ways in which the insulators may be attached to the multi-polar electrodes, or to an anode or cathode. These methods employ pins or inserts 61 (Figures 6A, 6B, 6C, 6D), tongue and grooves 63 (Figures 6A, 6B and 6C), dovetails 62 (Figures 6E, 6F, 6G), adhesive or the like, or a combination of two or more of these mounting features. In this way, the ceramic
10 materials can be fixed securely to the conductive electrode material to prevent dislodgement of the ceramic during operation of the cell. The fixtures can be asymmetric or "off-centre" as shown, or symmetric. If off-centre, the thicker electrode material is preferably positioned on the anode face of the electrode since that surface is more likely to experience wear and loss of material in use, and the
15 off-centre positioning thus increases the effective operating life of the cassette.

Figure 7A is a partial view of the top of an electrode cassette which illustrates another preferred embodiment of the invention in which the insulators 33 are interconnected to form a unitary block 33A. As in the embodiment of Figure 3, the multi-polar electrodes 21 are each capped at their upper ends 29 with an
20 elongated insulator 33 that covers the entire upper end surface of the electrode. However, the insulators 33 are joined together by spacers 34 and end plates 35. The gaps 36' between the spacers and end plates align with the inter-electrode gaps 36 between the electrodes 21. While the spacers 34 and end plates 35 extend across the inter-electrode gaps, they are narrow enough not to impede the flow of
25 electrolyte unduly. However, they support the insulators 33 and make the cassette more rigid and secure.

Fig. 7B shows a similar arrangement for cylindrical electrode cassettes. Again, as in the previous embodiment, the insulators 33 may be joined to form a block 33B of ceramic material having the shape as shown in Figure 7B. For simplicity,
30 this figure shows only two multi-polar electrodes 21 and only one half of the electrode cassette. It can be seen that the block 33B consists of insulators 33 that

are circular (in plan view) with rounded upper ends 55. A circular gap 36' aligns with the inter-electrode gap 36 between the electrodes 21. Spacers 34 interconnect the insulators in diametrically opposed positions, thus unifying the block 33B. Again, the spacers 34 do not unduly restrict the flow of electrolyte.

5 For all exemplary embodiments, the following generally comments can be made about the dimensions of the insulators 33. Clearly, the bigger an insulator is, the lower the consequent bypass loss will be. However, it is desirable not to change the fluid flow of a cell dramatically and to ensure that the electrolyte still flows over the tops of the multi-polar electrodes (and insulators). There is a decrease in gas lift
10 as more of the multi-polar electrode is replaced with an insulator as a fraction of the face of the multi-polar electrode will no longer be electrochemically active. There is therefore a trade-off between the size of the insulator blocks and the efficiency of cell operation. Along the top and bottom edges of multi-polar electrodes, electrical resistance to the bypass current is determined by the ratio of the length of the gap
15 between the adjacent insulators and the cross-sectional area of the gap which is proportional to its width. Optimization is preferred to achieve the best balance between the hydrodynamic resistance to electrolyte flow and the electrical resistance to bypass currents.

While any amount of insulation at the top ends of the multi-polar electrodes
20 offers an advantage, the preferred dimensions for the insulators can be stated as follows, in which the terms "width", "length" and "height" have the following meanings for cells having both planar and cylindrical electrodes:

Width: The through-thickness of the multi-polar electrode, parallel to the
25 direction that the current is traveling through the multi-polar electrode.

Length: The horizontal direction, parallel to the electrode face, generally normal to the current flow.

Height: The vertical direction, parallel to the face of the electrode face.

30

To define the height dimension of the insulators, reference is made to the gaps between the multi-polar electrodes (referred to as ACD). The electrodes are often equally spaced within an electrode cassette. Although a continuous improvement is obtained with increasing insulator height, a compromise in gas lift
5 (electrolyte flow) and available room in the cell must be made. A first preferred range of dimensions of the insulators is as follows:

- Width: Between 0.1 and 1.5 times the width of the underlying multi-polar electrode, and more preferably more than 0.5 times the width.
- 10 Length: Equal to the length of the multi-polar electrode (does not extend beyond the ends of the multi-polar electrodes).
- Height: 1 to 20 times the electrode gap (ACD).

A more preferred range of dimensions is as follows:

15

- Width: Between 0.5 and 1.0 times the width of the underlying multi-polar electrode.
- Length: Equal to the length of the multi-polar electrode.
- Height: 5 to 10 times the electrode gap (ACD).

20

In cells having more than one multi-polar electrode, it is desirable to provide insulators on the upper ends of all the multi-polar electrodes. However, the provision of insulators on only one or some of the multi-polar electrodes is better than having no insulators at all. Bypass currents over the tops of the multi-polar
25 electrodes are affected by electrolyte overflow depth, number of multi-polar electrodes, thickness of multi-polar electrodes and gap between multi-polar electrodes, decomposition potential and electrolyte conductivity. The effect of placing insulators at the electrode upper ends is to add an additional degree of resistance to the leakage current pathway. This extra electrical resistance, which is
30 developed by increasing the bypass current pathway through the electrolyte, has the effect of decreasing the overall bypass current.

developed by increasing the bypass current pathway through the electrolyte, has the effect of decreasing the overall bypass current.

An example of the variation of bypass current for a range of insulator heights (expressed as multiples of the ACD) has been calculated and is shown in Figure 8.

5 Insulator heights as low as about 1 times the ACD are effective, and beyond heights that are 20 times the ACD, the improvement with increased height is less. For practical reasons a height of more than 10 times the ACD is not preferred, and a height of at least 5 times the ACD ensures an economically useful effect on the bypass currents without a significant negative impact on the electrolyte flow or cell
10 productivity.

EXAMPLE

A test was carried out to demonstrate the suitability of the design,
15 ruggedness and materials employed in one form of the present invention. In the test, an electrolytic reduction cell having 24 planar multi-polar electrodes was provided with elongated rectangular insulators attached to the tops of four of the multi-polar electrodes. The refractory material used for the insulators was made from a 93% alumina / 5% silica castable mixture. The width of each insulator was
20 the same as that of the multi-polar electrode on which it rested, the length was the same as that of the multi-polar electrode length and the height was 6 times the average ACD.

The cell was operated for 685 days under normal conditions. The test showed that the cell operated properly, and, although the multi-polar electrodes
25 did erode over the operational lifetime of the cell, the insulator dimensions did not change and the insulators remained fixed to the top of the multi-polar electrodes.

Based on the design and dimensions of the insulators, the current efficiency was calculated, compared to a cell lacking such insulators and the results are plotted against cell life in Figure 9. This shows a consistently higher current
30 efficiency with even a few insulators over the case with no such insulators.

CLAIMS:

1. A multi-polar electrolytic cell for producing a light metal by electrolysis of a corresponding metal salt, the cell comprising:
 - a molten electrolyte containing a metal salt that produces a light metal and a gas when electrolyzed; and
 - an arrangement of generally vertical electrodes surrounded by said molten electrolyte, including an anode, a cathode and at least one current-conducting multi-polar electrode interposed between the anode and the cathode, said at least one multi-polar electrode having an upper end;
 - wherein said at least one multi-polar electrode has an electrical insulator positioned to extend at least partially over said upper end, and wherein, in use of said cell, said insulator is immersed beneath said electrolyte.
2. The cell of claim 1, wherein said insulator is attached to said multi-polar electrode.
3. The cell of claim 2, wherein said insulator is attached to said multi-polar electrode by a fastening means selected from the group consisting of pins, dovetails, interposed members, and adhesive.
4. The cell of any one of claims 1 to 3, wherein said insulator has a width between 0.1 and 1.5 times the width of the multi-polar electrode, a length substantially equal to the length of the multi-polar electrode and a height of 1 to 20 times an electrode gap between adjacent electrodes.
5. The cell of any one of claims 1 to 3, wherein said insulator has a width between 0.5 and 1.0 times the width of the multi-polar electrode, a length substantially equal to the length of the multi-polar electrode and a height of 5 to 10 times an electrode gap between adjacent electrodes.

6. The cell of any one of claims 1 to 5, wherein an insulating refractory shield is provided on the anode at a position confronting said upper end of an adjacent multi-polar electrode.

7. The cell of any one of claims 1 to 6, wherein the anode, cathode and said at least one multi-polar electrode are planar and are arranged parallel to each other.

8. The cell of any one of claims 1 to 6, wherein the cathode and said at least one multi-polar electrode each form a continuous body surrounding the anode.

9. The cell of any one of claims 1 to 6, wherein the cathode and said at least one multi-polar electrode are in the form of hollow cylinders surrounding the anode.

10. The cell of any one of claims 1 to 9, wherein said insulator is made of a material selected from the group consisting of alumina, magnesia, Mg-aluminate spinel, aluminum nitride, silicon nitride and SIALON.

11. A method of minimizing or eliminating by-pass current between an anode and a cathode in a multi-polar electrolysis cell suitable for production of a light metal, said method comprising:

electrically insulating an upper end of at least one multi-polar electrode of said cell, and

conducting electrolysis with said insulated upper end maintained below an upper surface of molten electrolyte containing a metal salt to be electrolyzed held within said cell.

12. A multi-polar electrolytic cell for producing a light metal by electrolysis of a corresponding metal salt, the cell comprising:

a molten electrolyte containing a metal salt that produces a light metal and a gas when electrolyzed; and

an arrangement of generally vertical electrodes surrounded by said molten electrolyte, including an anode, a cathode and a current-conducting multi-polar electrode interposed between the anode and the cathode, said multi-polar electrode having an upper end and an electrical insulator positioned to extend over said upper end;

wherein, in use of said cell, said insulator is immersed beneath said electrolyte.

13. The cell of claim 12, having at least one other multi-polar electrode interposed between said anode and said cathode.

14. The cell of claim 13, wherein said at least one other multi-polar electrode is provided with an electrical insulator positioned over an upper end thereof.

15. The cell of claim 14, wherein said insulators positioned above said multi-polar electrode and said at least one other multi-polar electrode are interconnected by a spacer made of refractory material.

16. The cell of claim 12, wherein said insulator is attached to said multi-polar electrode.

17. The cell of claim 16, wherein said insulator is attached to said multi-polar electrode by a fastening means selected from the group consisting of pins, dovetails, interposed members, and adhesive.

18. The cell of any one of claims 12 to 17, wherein said insulator has a width between 0.1 and 1.5 times the width of the multi-polar electrode, a length substantially equal to the length of the multi-polar electrode and a height of 5.0 to 10.0 times said width of an electrode gap between adjacent electrodes.

19. The cell of any one of claims 12 to 17, wherein said insulator has a width between 0.5 and 1.0 times the width of the multi-polar electrode, a length substantially equal to the length of the multi-polar electrode and a height of 1.0 to 10 times an electrode gap between adjacent electrodes.

5

20. The cell of any one of claims 12 to 19, wherein an insulating refractory shield is provided on the anode at a position confronting said upper end of the multi-polar electrode.

21. A multi-polar electrolytic cell for producing a light metal by electrolysis of a
10 corresponding metal salt or a method of minimising or eliminating by-pass current between an anode and a cathode in a multi-polar electrolysis cell suitable for production of a light metal substantially as herein described with reference to any one of the figures or examples but excluding comparative examples.

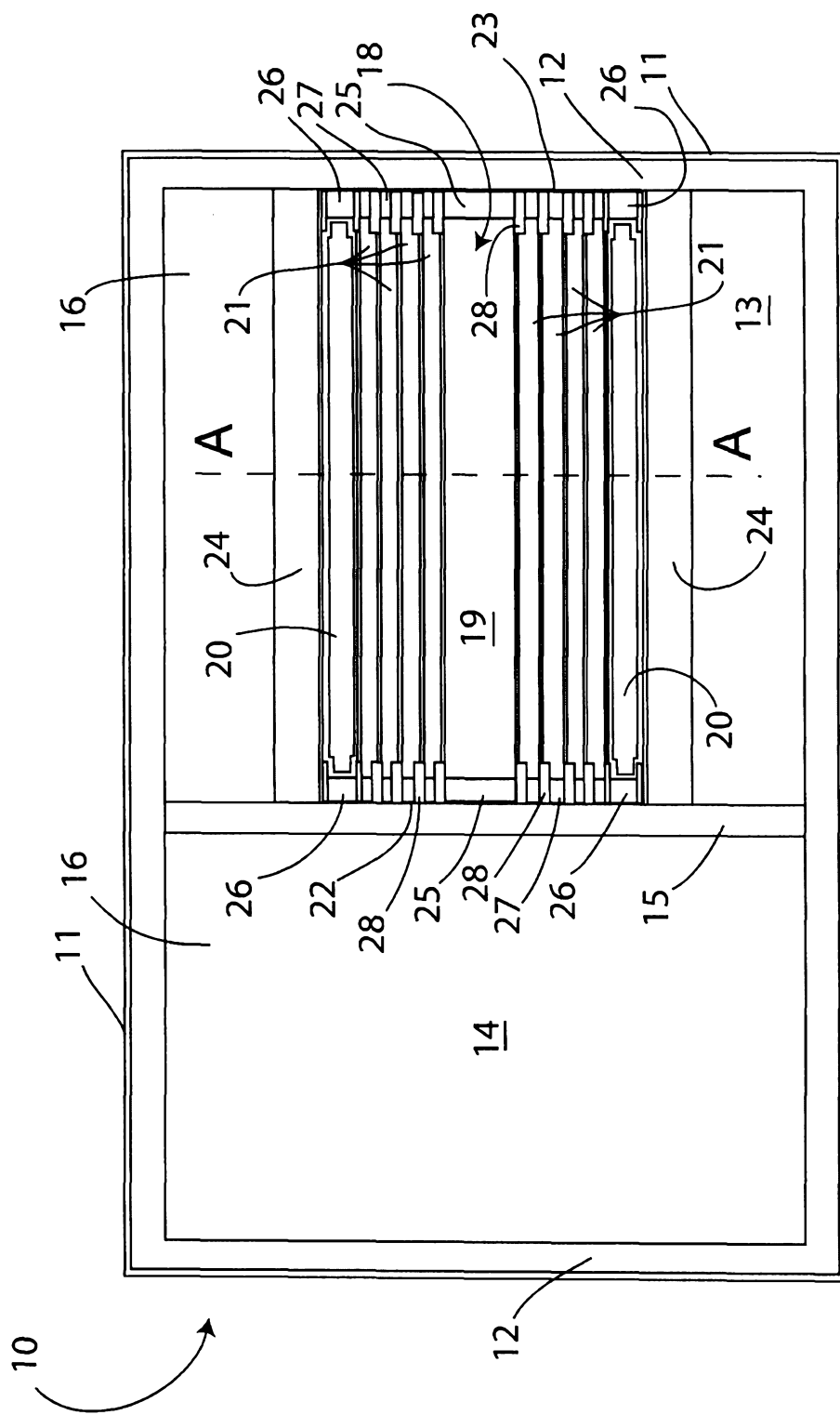

Fig. 1

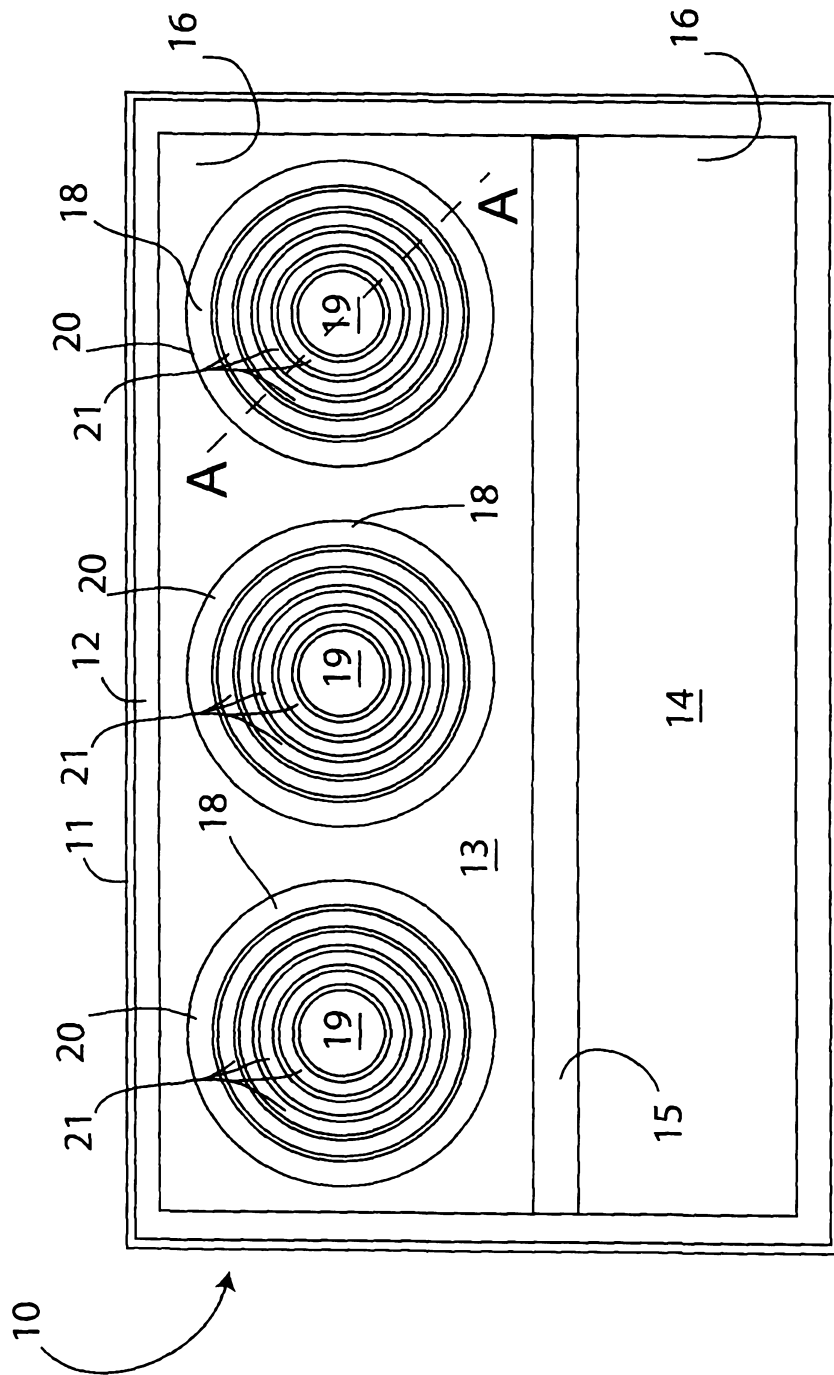

Fig. 2

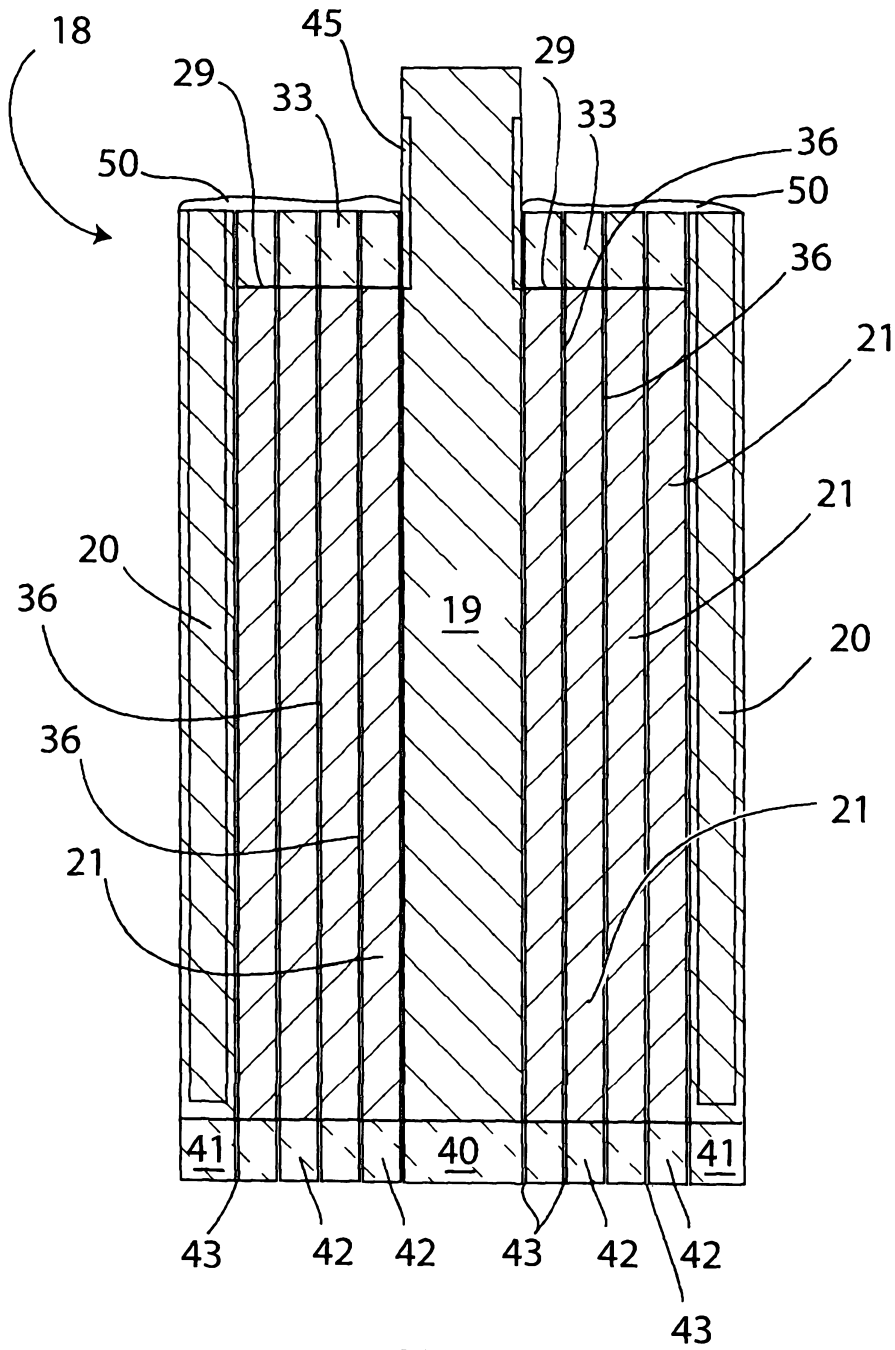

Fig. 3

4/9

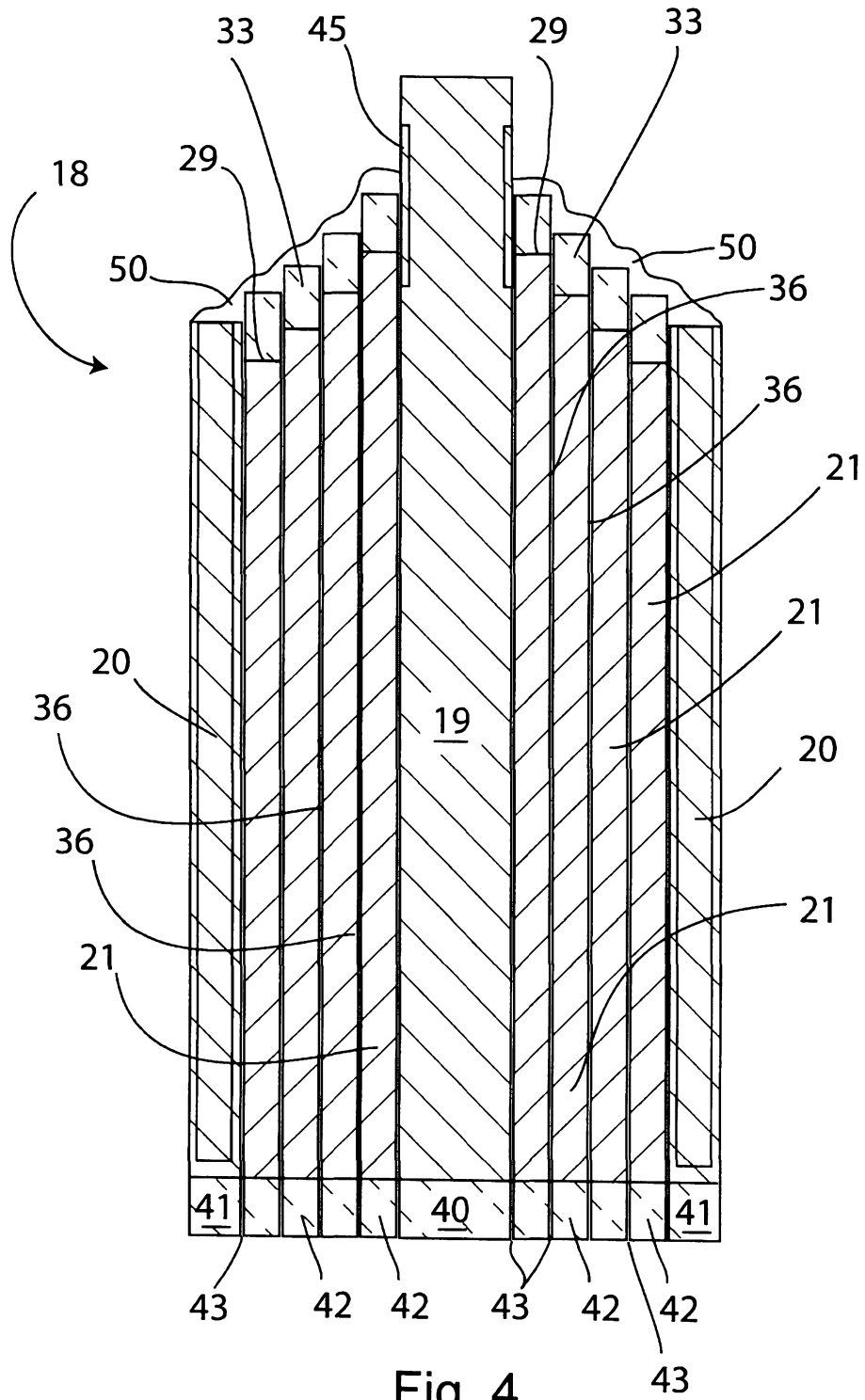

Fig. 4

5/9

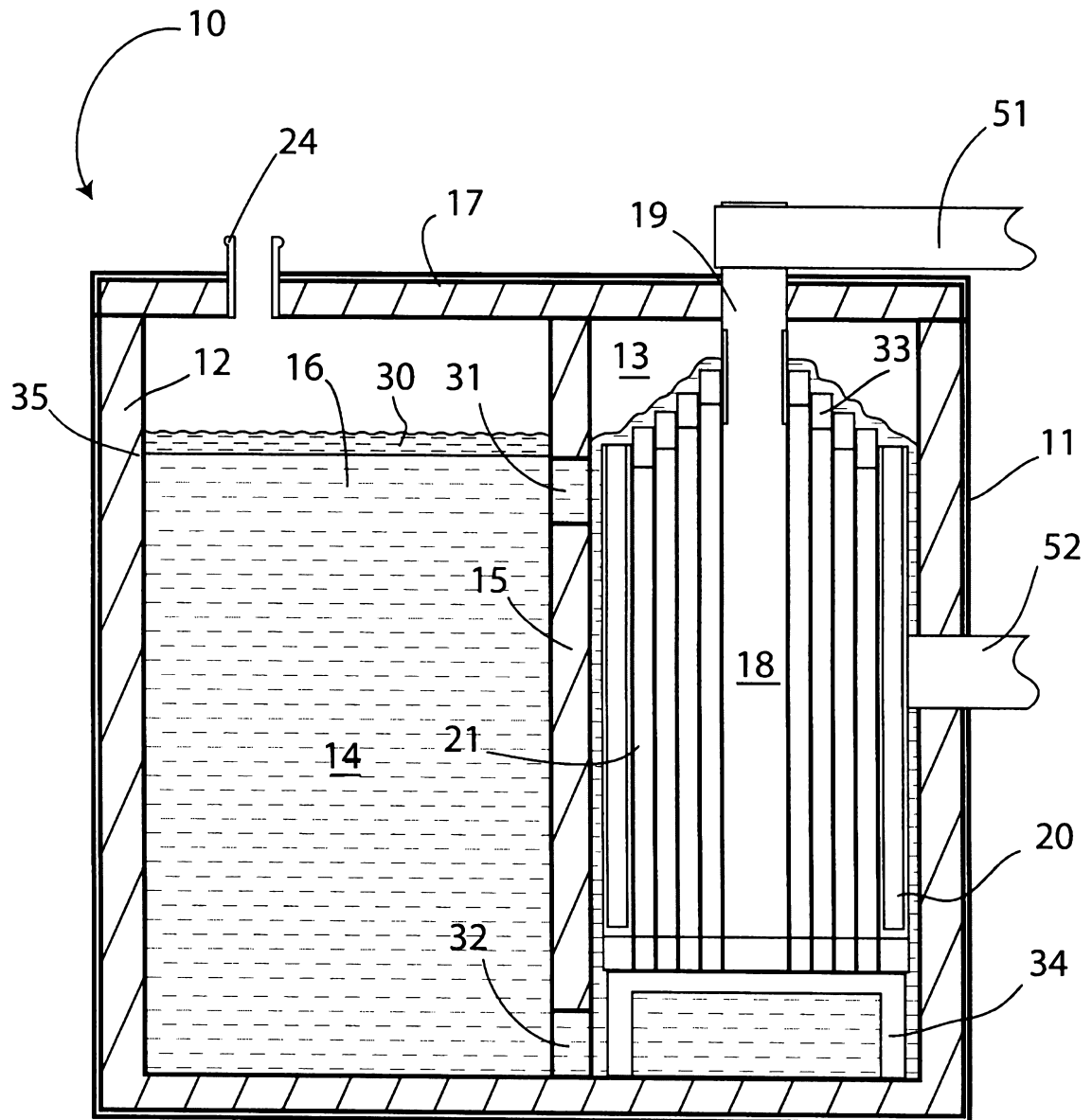
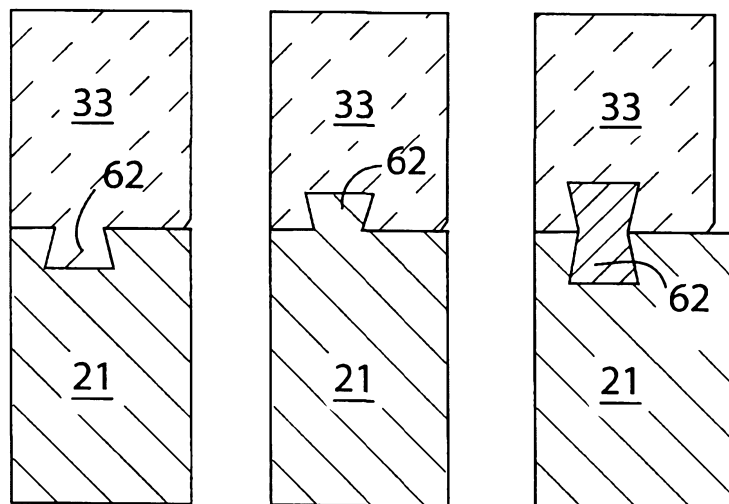
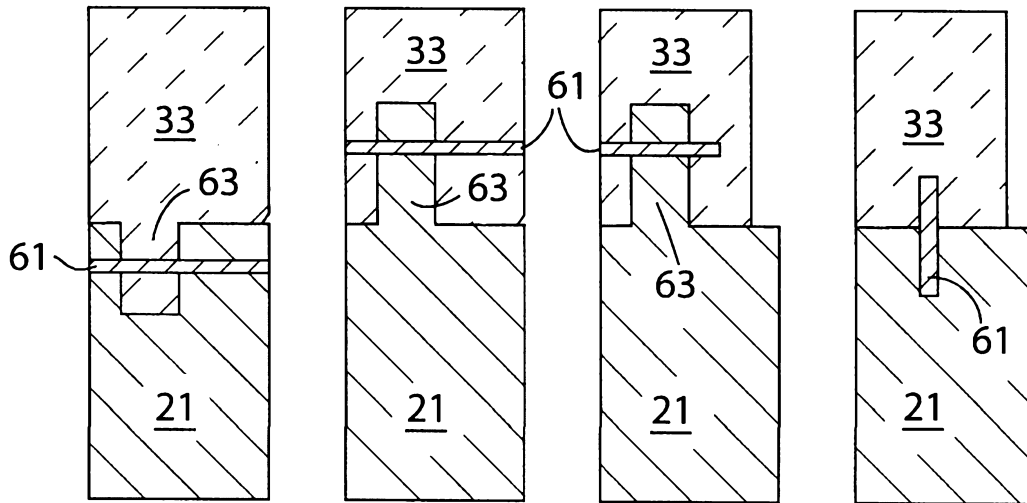

Fig. 5

6/9



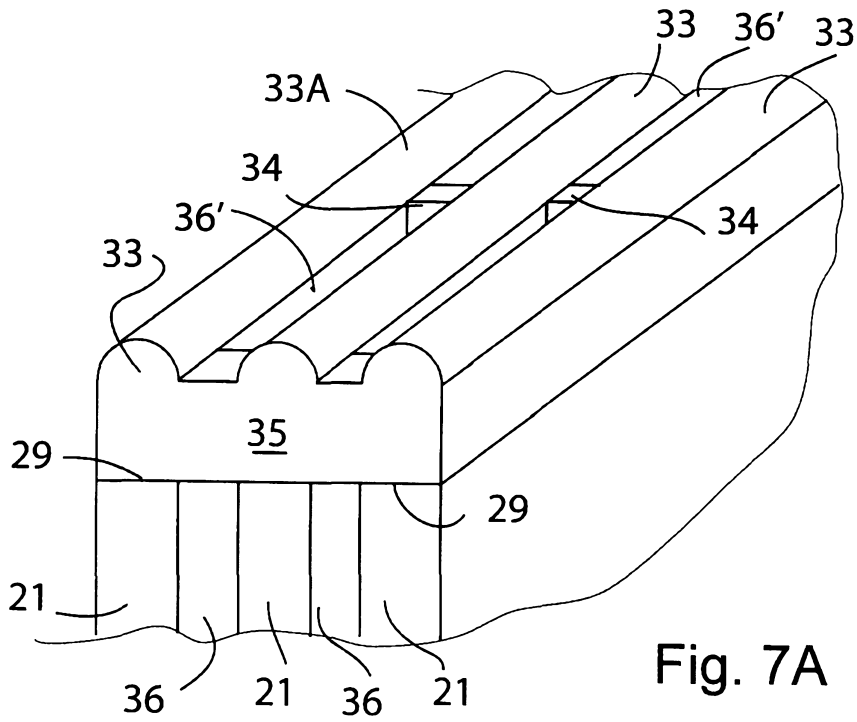

Fig. 7A

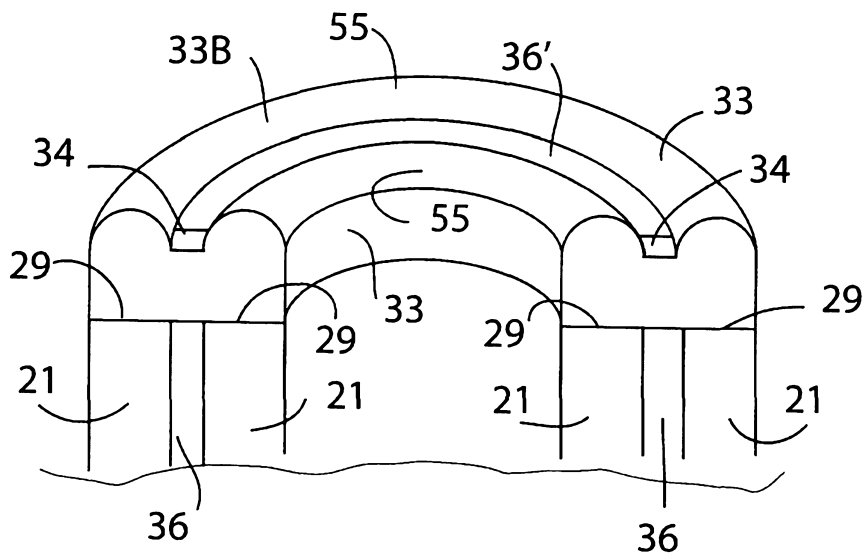

Fig. 7B

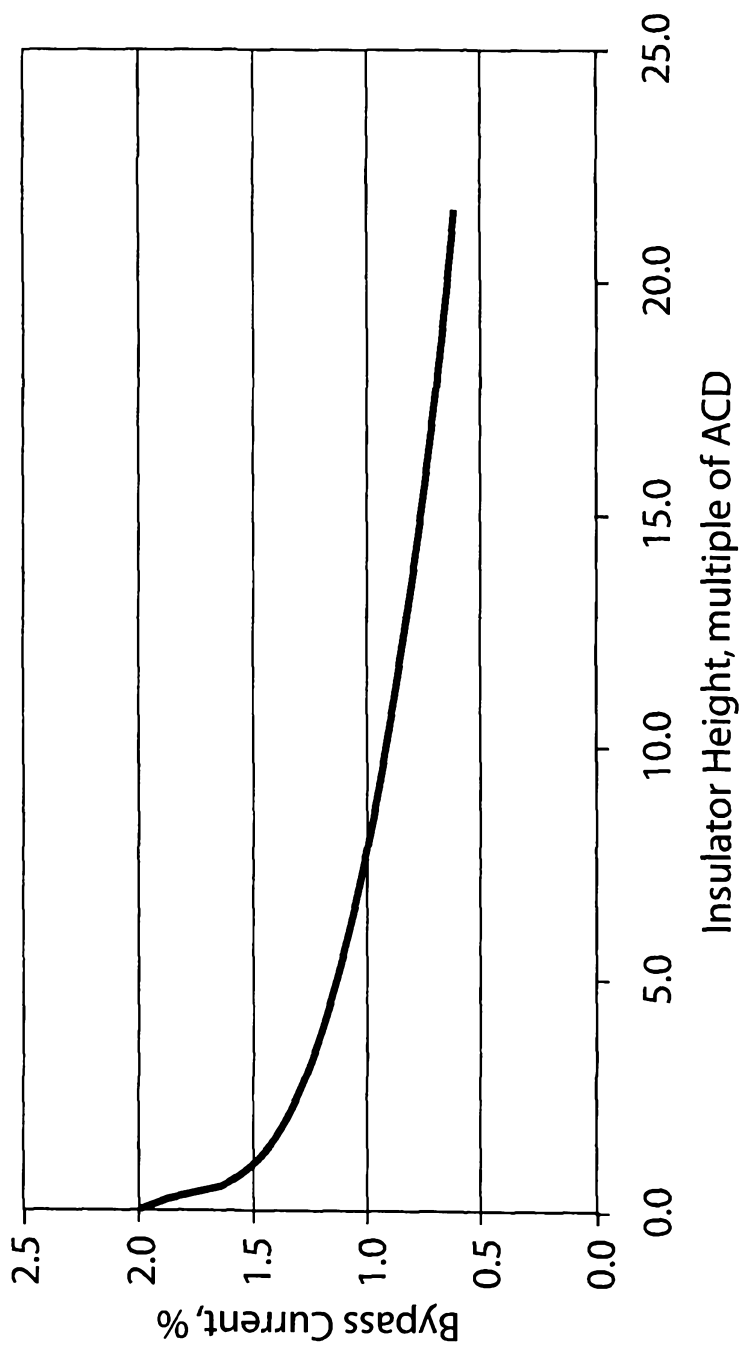

Fig. 8

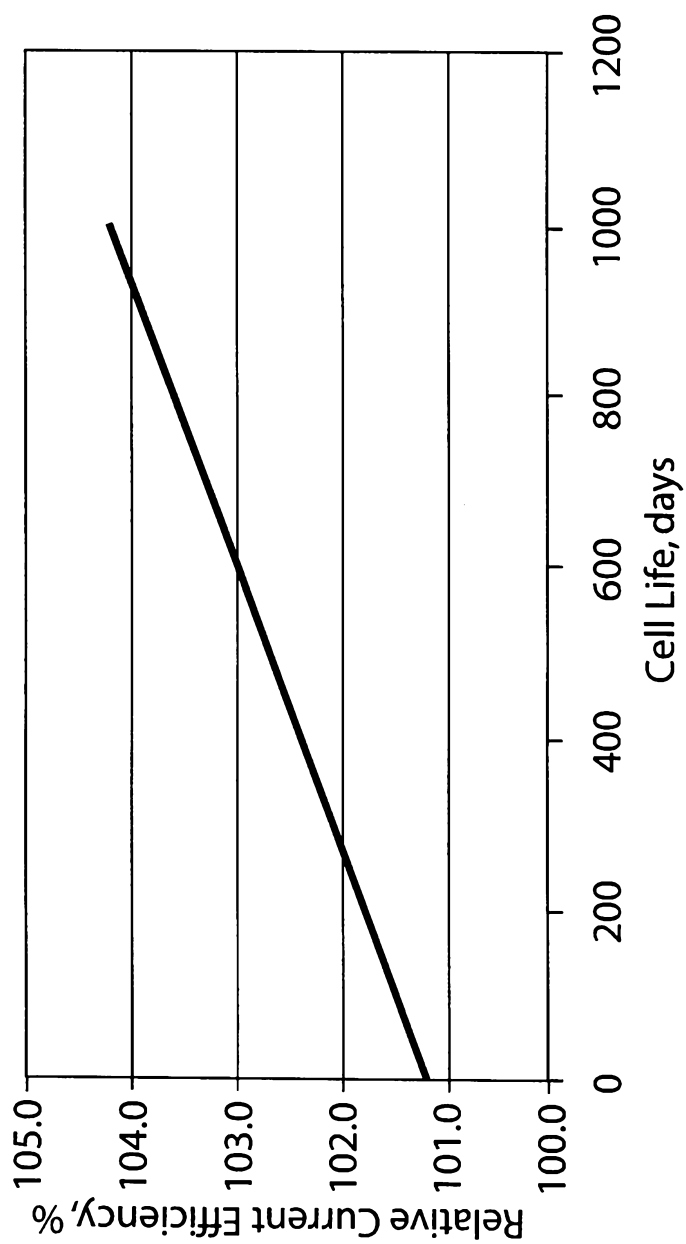

Fig. 9