

(19) World Intellectual Property Organization
International Bureau



(43) International Publication Date
6 November 2008 (06.11.2008)

PCT

(10) International Publication Number
WO 2008/134386 A2

- (51) International Patent Classification:
A61B 17/04 (2006.01)
- (21) International Application Number:
PCT/US2008/061359
- (22) International Filing Date: 24 April 2008 (24.04.2008)
- (25) Filing Language: English
- (26) Publication Language: English
- (30) Priority Data:
11/796,035 26 April 2007 (26.04.2007) US
- (71) Applicant (for all designated States except US):
ETHICON ENDO-SURGERY, INC [US/US]; 4545
Creek Road, Cincinnati, Ohio 45242 (US).
- (72) Inventors; and
- (75) Inventors/Applicants (for US only): STEFANCHIK,
David [US/US]; 5792 Cabernet Court, Morrow, Ohio
45152 (US). GRIFFITH, David B. [US/US]; 5097 Mey-
ers Lane, Cincinnati, Ohio 45242 (US).
- (74) Agents: JOHNSON, Philip S. et al.; One Johnson & John-
son Plaza, New Brunswick, New Jersey 08933 (US).
- (81) Designated States (unless otherwise indicated, for every
kind of national protection available): AE, AG, AL, AM,
AO, AT, AU, AZ, BA, BB, BG, BH, BR, BW, BY, BZ, CA,
CH, CN, CO, CR, CU, CZ, DE, DK, DM, DO, DZ, EC, EE,
EG, ES, FI, GB, GD, GE, GH, GM, GT, HN, HR, HU, ID,
IL, IN, IS, JP, KE, KG, KM, KN, KP, KR, KZ, LA, LC,
LK, LR, LS, LT, LU, LY, MA, MD, ME, MG, MK, MN,
MW, MX, MY, MZ, NA, NG, NI, NO, NZ, OM, PG, PH,
PL, PT, RO, RS, RU, SC, SD, SE, SG, SK, SL, SM, SV,
SY, TJ, TM, TN, TR, TT, TZ, UA, UG, US, UZ, VC, VN,
ZA, ZM, ZW.
- (84) Designated States (unless otherwise indicated, for every
kind of regional protection available): ARIPO (BW, GH,
GM, KE, LS, MW, MZ, NA, SD, SL, SZ, TZ, UG, ZM,
ZW), Eurasian (AM, AZ, BY, KG, KZ, MD, RU, TJ, TM),
European (AT, BE, BG, CH, CY, CZ, DE, DK, EE, ES, FI,
FR, GB, GR, HR, HU, IE, IS, IT, LT, LU, LV, MC, MT, NL,
NO, PL, PT, RO, SE, SI, SK, TR), OAPI (BF, BJ, CF, CG,
CI, CM, GA, GN, GQ, GW, ML, MR, NE, SN, TD, TG).

[Continued on next page]

(54) Title: SURGICAL SUTURING APPARATUS

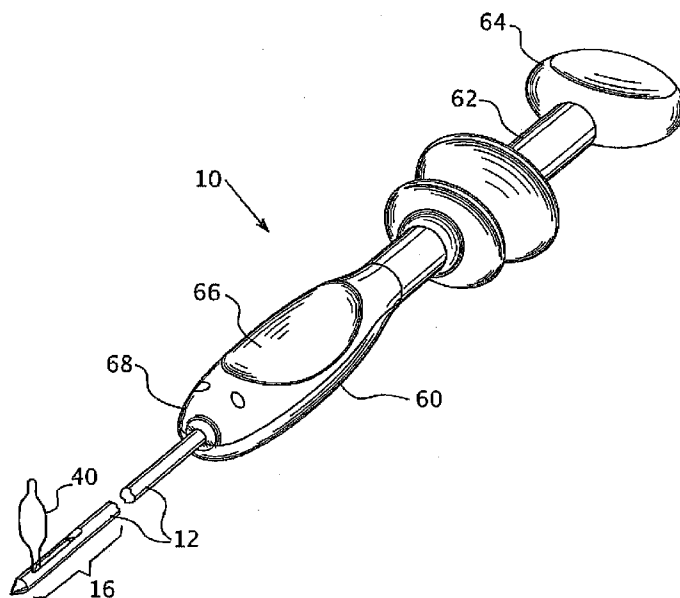

FIG. 1

(57) Abstract: A surgical suturing apparatus is described. The suturing apparatus has a needle having at least one pointed end, a channel for releasably receiving the needle, a needle positioning assembly having members for moving the needle and an actuation assembly for actuating the needle positioning assembly. The needle includes a first puncturing point at a proximal end thereof and an engagement section adjacent thereto, a distal end, which may have a second puncturing point, and another engagement section adjacent the distal end. A structure, such as an eye or a slot, is provided to secure a length of suture material to the needle. The members for moving the needle include an engagement member for releasably engaging one of the engagement sections of the needle to effect axial movement of the needle within the channel, a ramp member for effecting movement of the needle in the distal direction along the longitudinal axis of the channel and for urging the proximal end of the needle out of the channel, and a snare

axially movable within the channel and having a portion releasably housed within the channel. The snare portion is configured for capturing the proximal engagement section of the needle to guide the needle in a proximal direction when the needle is out of the channel and to guide the return of the needle to the channel.

WO 2008/134386 A2



Published:

- *without international search report and to be republished upon receipt of that report*

SURGICAL SUTURING APPARATUS

FIELD OF THE INVENTION:

[0001] The present invention relates to tools for surgical suturing, and more particularly, to a tool for endoscopic surgical suturing, including natural orifice transenteric surgery.

BACKGROUND

[0002] Sutures are used to approximate, or bring together, tissue separated, for example, by some trauma, or wound or during a surgical procedure to close an incision or an organ perforation. Suturing instruments generally include a needle and a trailing length of suture material. In endoscopic procedures, the instruments placed through an instrument channel may include needles and sutures for stitching such a wound, incision or perforation within the patient's body cavity. An exemplary suturing device is shown in U.S. Patent No. 7,131,978.

[0003] Physicians have often used endoscopes to examine, to biopsy, and to ablate the tissue of patients within lumens such as the esophagus and the bowel or other body cavity and internal patient sites. An endoscope generally includes either a rigid or flexible tube containing one or more optical fiber systems and, for operative uses (human or veterinary), one or more channels for passage of medical instruments. The optical system includes a light delivery system to illuminate the organ or site under inspection and a camera system to transmit the image of the site of interest to the viewer. The light source is normally outside the body and the light is typically directed via optical fiber bundles to the area of interest. A physician performing a therapeutic procedure with the use of an endoscope places a long, flexible instrument through the endoscope's instrument channel and then positions the instrument near the site within the body cavity, lumen or other internal site of interest where a therapeutic procedure is to be performed.

[0004] A physician performing a therapeutic procedure with the use of an endoscope places a long, flexible instrument through the endoscope's instrument channel and then positions

the instrument near the site within the body lumen where a procedure is to be performed. The instrument channels and optical fiber bundles open into the body at the distal end of the endoscope and are generally parallel to the axis of the flexible endoscope. Physicians place flexible instruments through the instrument channels while visualizing and illuminating an internal site using the optical fiber bundles.

[0005] More recently, a surgical technique known as natural orifice transenteric surgery (NOTES) is attracting interest. NOTES, which enables "scarless" abdominal operations, may be performed with an endoscope that is passed through a natural orifice (mouth, nose, anus, etc.), then through an internal incision in the stomach or colon, for example, thus avoiding any external incisions or scars. The NOTES technique has been used for diagnostic and therapeutic procedures in animal models, including transgastric (through the stomach) organ removal. Transcolonic approaches are also advocated for access to upper abdominal structures that may be more difficult to work with using a transgastric approach.

SUMMARY OF THE INVENTION

[0006] An improved surgical suturing apparatus is provided. The suturing apparatus has a needle, a channel, and members for moving the needle. The channel has a longitudinal axis, a distal end and a proximal end, and defines a housing at its distal end having an opening therein. The needle is releasably disposed within the housing and has a first end and a first puncturing point at a second end thereof. The needle includes a structure, such as an eye, slot, hook, sleeve or similar structure, for attachment to a length of suture material. The needle preferably has a first engagement surface adjacent the first end and a second engagement surface adjacent the first puncturing point.

[0007] The suturing apparatus also includes a needle positioning assembly having members movable relative to the channel for effecting a desired number of release and retrieval cycles for releasing the needle from the housing and guiding the return of the needle to the housing. An actuation assembly for controlling the members of the needle positioning assembly is also provided. When a length of suture material is attached to the needle, the puncture of

tissue with the first puncturing point and movement of the needle through tissue in a first direction threads the suture material through the tissue to provide a stitch.

[0008] At least one suture tag may be provided. Each suture tag has at least one passage therethrough for attachment to the suture material. The suture tags may be configured for attachment at one or both of the ends of the length of suture for securing the suture to the tissue at the start of and/or at the completion of suturing. The needle may be left in place following suturing to function as a suture tag to secure the suture against slipping. An alternative suture tag design includes inner and outer tapered cylinders. The inner cylinder may be co-axial relative to and axially movable within the outer cylinder in a telescoping manner. At least one passage is provided in each of the inner and outer cylinders. In one embodiment, the inner cylinder has two passages for passage of the length of suture material. The inner cylinder may be wedged into the outer cylinder to lock the suture tag and the suture in place at the sutured site.

[0009] In one embodiment, the needle positioning assembly may include an engagement member, a ramp member and a snare member. The engagement member is configured for releasably engaging the needle to effect axial movement of the needle within the channel. The ramp member is movable axially within the channel and is configured for operative contact with the needle for effecting movement of the needle to a first stage of progression adjacent the opening of the housing and to a second stage of progression wherein at least the first puncturing point is out of the housing. The snare member is movable and has a portion configured for engagement with the needle for guiding the needle when the needle is out of the housing. The portion of the snare member may comprise a noose for engagement with the second engagement surface of the needle, an expandable loop proximal to the noose and biased away from the longitudinal axis of the channel, and an elongate section proximal to the loop and operatively connected to the actuation assembly. In one embodiment, movement of the elongate section in the distal direction positions the noose and loop adjacent the opening of the housing to enable the release of the loop and noose from the channel, and movement of the elongate section in the proximal direction when the noose and loop are out of the channel effects the return of the loop and the noose to the channel.

[0010] The ramp member of the needle positioning assembly may include a rail operatively connected to the actuation assembly at a proximal end of the rail and a slope at a distal end of the rail for contact with the needle. In this embodiment, the slope, when moved into the second stage of progression, urges the needle from the housing at an angle to position the first puncturing point at a desired location for puncturing tissue.

[0011] The engagement member of the needle positioning assembly may include an elongate portion operatively connected to the actuation assembly and a pair of tines for engaging the needle at the first engagement surface.

[0012] In one embodiment, the actuation assembly includes a body portion, a handle and a plurality of rods operatively connected to the members of the positioning assembly for controlling movement of the needle. The plurality of rods in this embodiment may include a first push rod housed in the body portion and operatively connected to the handle and the engagement member for driving axial movement of the engagement member, a second push rod housed in the body portion and operatively connected to the handle and the ramp member for driving axial movement of the ramp member to the first stage of progression and for driving movement of the ramp member in the second stage of progression, a lock mechanism for locking the second push rod against movement of the ramp member to the second stage of progression, a release mechanism for selectively unlocking the second push rod to trigger movement of the ramp member to the second stage of progression, and a third push rod housed in the body portion and operatively connected to the handle and the snare member for driving axial movement of the snare member to a position for release of the portion of the snare from the channel and for return of the portion to the channel.

[0013] In one embodiment of the suturing apparatus, movement of the third push rod in a distal direction positions the portion of the snare member within the opening in the housing to effect the release of the portion of the snare member for engagement with the needle, and movement of the third push rod in a proximal direction when the portion engages the needle effects (i) the proximal travel of the needle when the needle is out of the housing to pull the needle through tissue in the proximal direction and (ii) the return of the portion of the snare

member and the needle to the channel. The actuation assembly may further include a trigger for moving the snare portion distally to the opening in the housing.

[0014] The lock mechanism may include a pin or a similar structure extending outwardly from the second push rod, and a locking plate having a notch therein for stopping the pin against movement in a distal direction beyond the notch. The release mechanism in this embodiment may comprise a lever for lifting the locking plate to release the pin from the notch.

[0015] The channel may be configured at the distal end thereof to enable the puncture of tissue in a first direction. Alternatively, the channel may be open at the distal end thereof to expose a second puncturing point at the first end of the needle to effect a puncture of tissue in a first direction when the channel is moved in the first direction. When a length of suture material is attached to the eye of the needle, the puncture of tissue with the second puncturing point and movement of the needle through the tissue in the first direction threads the suture material through the tissue. The puncture of tissue with the first puncturing point and movement of the needle through the tissue in a second direction threads the suture material through the tissue in the second direction to define a first stitch through the tissue. Multiple stitches may be made in this manner.

[0016] Methods of suturing with the suturing apparatus and a method for sterilizing the suturing apparatus are also provided.

BRIEF DESCRIPTION OF THE DRAWINGS

[0017] The novel features of the invention are set forth with particularity in the appended claims. The invention itself, however, both as to organization and methods of operation, together with further objects and advantages thereof, may best be understood by reference to the following description, taken in conjunction with the accompanying drawings in which:

FIG. 1 is a perspective view of an embodiment of the suturing apparatus of the present invention.

FIG. 2A is a partial view of one embodiment of the channel member showing one embodiment of the needle in the needle housing;

FIG. 2B is a partial view of an alternative embodiment of the channel member showing an alternative embodiment of the needle in the needle housing;

FIG. 2C is a partial view of the embodiment of the channel member of FIG. 2A showing the embodiment of the needle of FIG. 2B in the needle housing;

FIG. 3 is a partial view of an embodiment of the channel member showing the ramp pushing the needle of FIG. 2C out of the needle housing.

FIG. 4 is a partial view of the channel member showing the snare lowered onto the proximal neck of the needle.

FIG. 5 is a partial view of the channel member showing the snare pulling the needle out of the needle housing.

FIG. 6 is a partial view of the channel member showing the snare pulling the needle proximally through tissue.

FIG. 7 is a partial view of the channel member showing the snare lowering the needle back into the needle housing.

FIG. 8 is a partial view of the channel member showing the needle returned to the needle housing.

FIG. 9 is a partial view of the channel member showing the fork member pushing the needle distally to its starting position within the needle housing.

FIG. 10 is a view of the channel member and needle after passing from the proximal to the distal side of the tissue.

FIG. 11 is a view of the stitch that would be provided by a single stitch sequence through the tissue.

FIG. 12 is a view demonstrating a suturing technique wherein tissue is punctured only with the needle and not with the channel member.

FIG. 13 is a view of an embodiment of a suture anchor attached to a length of suture.

FIGS. 14A and B are section views of the actuation mechanism of the suturing apparatus of the present invention in two stages of operation.

FIG. 15 is a side section view of the actuation mechanism of FIGS. 14A and B.

DETAILED DESCRIPTION

[0018] Before the present method and embodiments of an instrument are disclosed and described, it is to be understood that this invention is not limited to the particular process steps and materials disclosed herein as such process steps and materials may vary somewhat. It is also to be understood that the terminology used herein is used for the purpose of describing particular embodiments only and is not intended to be limiting since the scope of the present invention will be limited only by the appended claims.

[0019] Unless defined otherwise, all technical and scientific terms used herein have the same meaning as commonly understood to one of ordinary skill in the art to which this invention belongs. Although any method, instrument and materials similar or equivalent to those described herein may be used in the practice or testing of the invention, particular embodiments of a method, instrument and materials are now described.

[0020] It must be noted that, as used in this specification and the appended claims, the singular forms "a," "an," and "the" include plural referents unless the content clearly dictates otherwise.

[0021] In describing and claiming the present invention, the following terminology will be used in accordance with the definitions set out below.

[0022] As used herein, the term "patient," used herein, refers to any human or animal on which a suturing procedure may be performed.

[0023] As used herein, the term "biocompatible" includes any material that is compatible with the living tissues and system(s) of a patient by not being substantially toxic or injurious and not causing immunological rejection. "Biocompatibility" includes the tendency of a material to be biocompatible.

[0024] As used herein, the term "bioabsorbable" includes the ability of a material to be dissolved and/or degraded, and absorbed, by the body.

[0025] As used herein, the term "integral" or "integrally" means that two or more parts so described are affixed, fastened or joined together so as to move or function together as a substantially unitary part. "Integral" and "integrally" include, but is not limited to, parts that are continuous in the sense that they are formed from the same continuous material, but also includes discontinuous parts that are joined, fastened or affixed together by any means so as to become substantially immovably affixed to, and substantially unitary with, each other.

[0026] As used herein, the term "proximal" (or any form thereof), with respect to a component of an instrument, means that portion of the component that is generally nearest the practitioner, physician, or surgeon, or nearest to the end of the instrument handled by the practitioner, physician, or surgeon, when in use; and with respect to a direction of travel of a component of an instrument, means toward the end of the instrument generally nearest the practitioner, physician, or surgeon, or handled by the practitioner, physician, or surgeon, when in use.

[0027] As used herein, the term "distal" (or any form thereof), with respect to a component of an instrument, means that portion of the component that is generally farthest from the practitioner, physician, or surgeon, or farthest from the end of the instrument handled by the

practitioner, physician, or surgeon, when in use; and with respect to a direction of travel of a component of an instrument, means away from the end of the instrument generally nearest the practitioner, physician, or surgeon, or handled by the practitioner, physician, or surgeon, when in use.

[0028] As used herein, the term "longitudinal axis", with respect to an instrument, means the exact or approximate central axis defined by said instrument along its greater dimension, i.e., along its length, from its distal end to its proximal end, and vice versa, and is not intended to be limited to imply a straight line, wherein, for example, an instrument includes a bend angle as described herein, it is intended that "longitudinal axis" as used herein follows such bend angle.

[0029] As used herein, the term "axial" or "axial movement" or variants thereof, with respect to an instrument or a component of an instrument, means the movement in the direction of the longitudinal axis of such instrument.

[0030] As used herein, the term "operatively connected" with respect to two or more components, means that operation of, movement of, or some action of one component brings about, directly or indirectly, an operation, movement or reaction in the other component or components. Components that are operatively connected may be directly connected, may be indirectly connected to each other with one or more additional components interposed between the two, or may not be connected at all, but within a position such that the operation of, movement of or action of one component effects an operation, movement or reaction in the other component in a causal manner.

[0031] As used herein, the term "internal site" of a patient means a lumen, body cavity or other location in a patient's body including, without limitation, sites accessible through natural orifices or through incisions.

[0032] The present invention has application in conventional endoscopic and open surgical instrumentation, as well as application in robotic-assisted surgery. The embodiments shown illustrate the use of the invention in connection with an endoscope within an internal site

of a patient. The invention is useful in a variety of minimally invasive medical procedures, including without limitation medical procedures performed through laparoscopic incisions for access to body cavities and internal organs of the body. The invention also encompasses apparatus and methods employing endoscopic devices in general, including various forms and variations of endoscopes, including without limitation: laparoscopes, gastroscopes, peritoneoscopes, sigmoidoscopes, fiber optic endoscopes, arthroscopes, amnioscopes, and the like.

[0033] The suturing apparatus of the present invention includes a needle, a channel for housing the needle, a needle positioning assembly and an actuation assembly. One embodiment of the suturing apparatus 10 with an embodiment of an actuation assembly is shown generally in FIG. 1. In this embodiment, suturing apparatus 10 includes a body 60, handle knob 64, rod 62, thumb rest 66 and, extending from the distal end 68 thereof, a channel member 12. Channel member 12 may be rigid or flexible, cylindrical or in the form of a C-channel or a like shape suitable for insertion into a patient internal site. Although shown for ease of illustration as relatively short in length, channel member 12 is particularly well suited for use with an endoscope, so may be sized both in length and in cross-section to fit with ease into a working channel of an endoscope (not shown).

[0034] In the embodiment of channel member 12 shown in reference to FIGS. 2A and 2C - 10, the distal end 14 of channel member 12 has a sharp point or edge 18 for puncturing tissue. In another embodiment, the distal tip of channel 12 can incorporate a veriss needle feature to minimize tissue damage. A veriss needle is used in laparoscopic surgery for blind puncture and consists of a sharpened canula tip about 1 mm in diameter and a distally urged spring loaded blunt tip cylindrical rod that is close fitting inside the canula tip. As the sharp canula point punctures the full thickness of the tissue, the blunt rod is freed (*i.e.* the rod is no longer compressed against its spring by the tissue to be punctured) to advance past the sharp tip and protect other structures. The distal end of channel member 12 may be dimensioned, in cross-section, to about the size of, or slightly larger than, a standard surgical needle for ease of puncturing and passing through tissue. For example, the distal outer diameter of the end of

channel member 12 may be about 0.020 to 0.125 inches (about 0.051 to about 0.317 cm) in diameter (or similar cross-sectional dimension, if not cylindrical in shape).

[0035] As shown in FIG. 1, distal end 14 also includes a housing area 16 for housing shuttle needle 20. Referring to FIGS. 2A-C, the channel member 12 also houses a fork member 30 for engaging the distal end of needle 20, a ramp member 50 for urging shuttle needle 20 out of the opening 54 of needle housing 16 and a snare 40 for engaging the proximal end of shuttle needle 20 to guide shuttle needle 20 at various stages of the suturing operation, such as through to the proximal side 102 of tissue, back into the needle housing 16 and into the desired position within needle housing 16.

[0036] In the embodiment of shuttle needle 20 shown in FIGS. 2B and 2C, the needle 20 includes opposing dual puncturing points 22 and 24 and, in the embodiment shown, opposing engagement surfaces. The first or distal end of shuttle needle 20 includes puncturing point 22, which transitions to a first engagement surface formed by shoulder 36 and narrowed distal neck area 26. Shuttle needle 20 includes at its opposite, proximal end, a proximal puncturing point 24, which transitions to a second engagement surface formed by shoulder 38 and narrowed proximal neck area 28.

[0037] In the embodiment of shuttle needle 20 shown in FIG. 2A, the distal end of needle 20 is not pointed and may be rounded or flat. The proximal end of shuttle needle 20 includes a first, or proximal puncturing point 24. Opposing engagement surfaces are shown at each of the distal and proximal ends of shuttle needle 20 as described above. The first engagement surface is formed by shoulder 36 and narrowed distal neck area 26. The second engagement surface is formed by shoulder 38 and narrowed proximal neck area 28.

[0038] In the center body portion 48 of shuttle needle 20 is the eye 46 of the needle, or a similar structure through which a length of suture material 70 extends, generally from both sides of the eye 46 such that a double strand of suture is used in each stitch. The eye 46 is crimped closed during manufacture to lock the suture securely in the shuttle needle 20. Those skilled in the art will appreciate that any suitable structure for attaching a length of suture

material to the needle 20 will suffice. Examples include, without limitation, the eye 46, slots, hooks, sleeves and similar structures for attaching the suture material to the needle 20.

[0039] In an alternative embodiment of channel member 12, the distal end 14 of channel member 12 may be open, as shown in FIG. 2B, to allow the distal puncturing point 22 of shuttle needle 20 to extend therefrom to effect puncturing of tissue for channel member 12 in lieu of puncturing with the point 18. In this embodiment, the diameter of the opening at the distal end of channel member 12 would be about the same or less than the greatest diameter of puncturing point 22 to prevent shuttle needle 20 from exiting the channel member 12 at the open distal end and to keep the channel member as clear as possible.

[0040] Fork member 30 includes a pair of tines 32 at the distal end of fork member 30 and either one or two elongate rods 34 that extend in the proximal direction and are movable axially back and forth (or, distally and proximally relative, in use, to the practitioner) within the length of channel member 20. A single rod 34 may split into two rods to lead to the pair of tines 32 at any suitable location along its length. Dual rods 34 may alternatively be provided which lead in parallel, for example, to the tines 32, which bends upwardly to engage each side of the engagement surface at distal neck 26 of shuttle needle 20. When fork member 30 is moved distally, tines 32 push against distal shoulder 36 to move shuttle needle 20 distally with the fork member 30. When fork member 30 is moved proximally within channel member 12, tines 32 contact body portion 48 of shuttle needle 20 and push the shuttle needle 20 proximally with the fork member 30.

[0041] Ramp member 50, in the embodiment shown, is an elongate bar or rail having a ramp slope 52 at the distal end thereof. Ramp member 50 is movable axially, back and forth (or, distally and proximally relative, in use, to the practitioner) within the length of channel member 20. Ramp member 50 is slightly smaller in width than the diameter of the channel member 20 to allow unhindered axial movement within channel member 20, but to inhibit rotational movement or twisting within channel member 20. Alternatively, or in addition, ramp member 50 may be guided axially by a track member (not shown) running along at least a portion of the floor 56 and/or a portion of the ceiling of channel member 20.

[0042] Ramp member 50 is operatively connected, by any suitable known manner, or integrally connected, to a push rod 76, which is preferably biased in the distal direction, but locked against the complete advance of ramp member 50 in the distal direction by a locking mechanism 82 in body 60. Ramp member 50 advances distally in a limited, or first stage of distal progression upon actuation of push rod 76 in body 60 of apparatus 10, as shown in FIG. 14, and, advances distally in a more rapid, second stage of progression to urge at least the proximal end of shuttle needle 20 out of needle housing 16 upon release of locking mechanism 82, as explained more fully below.

[0043] Referring to FIGS. 14A, B and 15, push rod 76 has a pin 86 positioned at an intermediate location on one surface of the rod 76. The locking mechanism 82 includes a plate 84 having a track 88 to capture pin 86, and thereby limits the full progression of push rod 76. Push rod 76 can be moved axially by pushing or pulling rod 62. As shown in FIGS. 14A and B, when rod 62 is pushed in the distal direction, movement of rod 62 causes some axial movement of rod 76 in the distal direction. Pin 86 is carried by the movement of rod 76 from the stop section 92 to track 88 of locking mechanism 82. Track 88 is configured to allow pin 86 of push rod 76 to move in the proximal direction until pin 86 reaches stop notch 92, and in the distal direction until pin 86 reaches stop notch 94, thereby locking push rod 76 against further distal movement until button 72, or any suitable actuation device, actuates a lever that raises and lowers plate 84. As shown in FIG. 15, by raising plate 84, the track 88 is lifted away from pin 86, thereby releasing push rod 76. Because push rod 76 is biased in the distal direction, upon release of pin 86 from track 88, push rod 76 advances in the distal direction rapidly, thereby pushing ramp member 50 rapidly toward shuttle needle 20 and urging the proximal end of shuttle needle 20 upwards at an angle (about the angle of the ramp slope 52) and out of the opening 54 of needle housing 16.

[0044] As shown in FIG. 3, when ramp member 50 is advanced distally while shuttle needle 20 is positioned within needle housing 16 with the body portion 48 and the proximal puncturing point 24 positioned beneath opening 54, ramp slope 52 slides under proximal puncturing point 24 to urge body portion 48 and the proximal end of shuttle needle 20 upwards,

at an angle, out of opening 54. The distal end of shuttle needle 20 is held in place initially by tines 32 and the edge of channel member 12 at the distal end of opening 54.

[0045] Snare 40 is formed of wires 58 which extend along the length of channel member 12 to form a loop portion 44 and a noose 42 at the distal end of the snare 40. The proximal ends of wires 58 are operatively connected to, or integrally connected to, an actuation rod 80 in the body 60 of suturing apparatus 10. The noose 42 of snare 40 is configured to grab and hold the proximal neck 28 of shuttle needle 20 at a stage of the suturing operation, as described more fully below. The loop 44 of snare 40 is compressed within channel member 12 for certain stages of the suturing operation, when, as shown for example, in FIGS. 7-9, snare 40 is pulled in the proximal direction (for example, by pulling actuation rod 80 of apparatus body 60, or a similar member operatively connected to snare 40, in the proximal direction as shown in FIG. 14) such that that loop 44 is pulled into channel member 12 proximal to opening 54.

[0046] In use, suturing apparatus 10 may be used, for example, with an endoscope. The apparatus 10 of the present invention may also be used in a NOTES procedure. Those skilled in the art will recognize that the suturing apparatus 10 of the present invention may also be used in open surgery where the distal side 100 of tissue to be sutured is not readily accessible to the practitioner and a tool is deemed appropriate to facilitate such access.

[0047] When used with an endoscope, the distal end of channel member 12 would be inserted into the proximal end of a working channel of an endoscope to guide channel member 12 to an internal site of a patient undergoing a procedure requiring sutures at or near the internal site. The distal end of channel member 12 would be advanced to the distal end of the working channel of the endoscope and would exit the working channel and advance to the internal site to be sutured. Push rods 76, 78 and 80 may be operatively connected or linked to handle rod 62 such that all three advance at least some distance along their total possible paths when handle 62 is pushed in the distal direction. Thus, when the surgeon, or other practitioner, pushes handle 62 of apparatus 10 distally, the distal movement of the handle 62 drives fork member 30 distally, which in turn drives shuttle needle 20 distally to the desired position at the distal end of channel member 12, in position for the tissue puncture at the first puncture site selected by the surgeon.

Similarly, the snare 40 is advanced such that, as the channel member 12 approaches the tissue, the noose 42 of snare 40 is positioned proximal to proximal neck 28 of shuttle needle 20, within the channel member as shown in FIG. 2B. Ramp member 50 moves distally as well in its first stage of distal progression to push shuttle needle 20 close to the distal end of channel member 12. The first puncture site may be an existing puncture site or may be the initial puncture site in a procedure, such as a stomach reduction.

[0048] A trigger on body 60 or on handle 62 of apparatus 10 is pushed to advance snare 40 to position loop 44 beneath opening 54 so that it is free to pop out of opening 54, as shown in FIGS. 2C and 3. In one method of suturing tissue, the channel member 12 may be passed through the tissue. As the channel member 12 and shuttle needle 20 pass through the tissue, the snare 40 does not pass through the tissue, but extends out of channel member 12 on the proximal side 102 of the tissue and may rest on the tissue, as shown in FIG. 10, optionally providing some stabilization for the tissue being punctured. Referring to FIG. 10, the tip 18 of channel member 12 punctures the tissue at a first puncture site, passing from the proximal side 102 to the distal side 100 of the tissue. In the alternative embodiment described above and shown in FIG. 2B, the distal puncturing point 22 of shuttle needle 20 would be exposed through the open distal end of channel member 12 to puncture the tissue 102/100.

[0049] The channel member 12 is passed far enough through the tissue to pass shuttle needle 20 through to the distal side of the tissue. The suture material 70 attached to the eye 46 of shuttle needle 20 passes to the distal side of the tissue with the shuttle needle 20. At this stage of the suturing operation, the shuttle needle 20 is positioned within needle housing 16, with tines 32 of fork member 30 engaging the distal neck 26. Ramp member 50 is spaced axially from shuttle needle 20 and loop 44 and noose 42 of snare 40 are outside of channel member 12.

[0050] The fork member 30 pulls the shuttle needle 20 back in the proximal direction to position all but the distal end and neck of shuttle needle 20 beneath opening 54. To create the back stitch (*i.e.*, to pull the suture material through to the proximal side of the tissue at a second puncture site spaced from the first puncture site), the locking mechanism 82 is released, as described above, to allow ramp member 50 to rapidly advance distally in its second stage of

progression, contact the shuttle needle 20 and urge shuttle needle 20 upwardly at an angle, as shown in FIG. 3, in a barbed, harpoon-like configuration relative to channel member 12.

[0051] At this stage, channel member 12 is pulled in the proximal direction, pulling the proximal puncturing point 24 of shuttle needle 20 with it. However, channel member 12 will pass back through the first puncture site, while the proximal puncturing point 24 of shuttle needle 20 will be pulled, still at an angle, proximally through a second puncture site, moving from the distal side of the tissue 100 to the proximal side of the tissue 102 and leading the suture material 70 proximally with it to create a stitch, as shown in FIG. 11. As the proximal puncturing point 24 of shuttle needle 20 punctures the tissue, the distal end of shuttle needle 20 is securely held in the distal end of channel member 12 by tines 32.

[0052] Before the distal end of channel member 12 can be moved completely back to the proximal side of the tissue 102, however, the shuttle needle 20 has to be completely removed from the needle housing 16. Referring to the sequence shown in FIGS. 4-6, when the proximal puncturing point 24 of shuttle needle 20 is on the proximal side of the tissue 102, noose 42 is lowered onto, and grabs the second engagement surface at the proximal neck 28 of shuttle needle 20. (FIG. 4) When shuttle needle 20 is securely within the noose 42 of snare 40, fork member 30 is pulled in the proximal direction, releasing the distal neck and shoulders 26, 36 of shuttle needle 20, (FIG. 4) allowing snare 40 to pull shuttle needle 20 completely out of needle housing 16 (FIG. 5). When free of shuttle needle 20, channel member 12 is free to be completely drawn back to the proximal side of the tissue 102 through the first puncture site (FIG. 6). Snare 40 moves with channel member 12 in the proximal direction, pulling shuttle needle 20 completely through the second puncture site of the tissue.

[0053] In the next stage of the suturing procedure as shown in FIG. 7, snare 40 lowers shuttle needle 20 back into the needle housing 16 through opening 54. Prior to or simultaneously during this stage, ramp member 50 is pulled in the proximal direction, to clear the needle housing for the return of shuttle needle 20. Snare 40 is pulled in the proximal direction by pulling the rod 62, and thereby rod 80 to which snare wires 58 are directly or operatively attached, in the proximal direction. Ramp member 50 is pulled proximally and lock mechanism 82 is re-engaged

by lowering plate 84 and with it, notch 88. As shown in FIG. 8, the shuttle needle 20 is pulled into needle housing 16 and the tines 32 of fork member 30 re-engage the distal neck 26 of shuttle needle 20. As shown in FIG. 9, fork member 30 and snare 40 push shuttle needle 20 in the distal direction within channel member 12, back toward the distal end thereof in position to begin another stitch through the tissue in the distal direction. The process is repeated until the desired number of stitches has been made.

[0054] Alternatively, the suturing can take place by passing only the shuttle needle 20 through tissue while keeping the channel member 12 on the proximal side 102 of the tissue. Referring to Fig. 12, the tissue is punctured by passing the proximal tip 24 of shuttle needle 20 through a section of tissue. The same procedure for lifting the needle 20 out of the needle housing 16 through opening 54 is carried out, as shown in FIG. 3. The needle 20 is pulled by pulling the channel member 12 while the needle 20 is still held by tines 32 to advance the tip 24 through the desired section of tissue. Needle 20 is further advanced and pulled through the tissue by the procedure shown and described with reference to FIGS. 4-6 above, then lowered back into needle housing 16 as shown in FIG. 7. The process is repeated until the desired number of stitches has been made.

[0055] Another tool would be used to tie off, or knot the suture ends before cutting the suture from shuttle needle 20 to complete the suturing procedure. A suture anchor, or suture tag having co-axial inner and outer cylinders axially movable relative to each other, may be provided. The outer cylinder of one embodiment of such a suture anchor may have a tapered inner surface and the inner cylinder may have a tapered outer surface for complementary locking engagement with the tapered inner surface of the outer cylinder to lock the suture material in a desired position. As shown in FIG. 13, a suture anchor or tag 106 having an outer tapered cylinder 108 and a co-axial inner tapered cylinder 110, positioned within outer tapered cylinder 108, can be used to tie off one or both ends of the suture. The suture 70 is directed through three passages 112, 114 and 116. The suture tags 106 are configured for attachment at one or both of the ends of the length of suture 70 for securing the suture 70 to the tissue at the start of and/ or the completion of suturing.

[0056] Referring to FIG. 13, the suture tag 106 may be tied to the suture by drawing the suture 70 through passage entrance 112b in outer tapered cylinder 108, then through passage entrance 114a of inner tapered cylinder 110, out through passage exit 114b and over the surface of inner cylinder 110 to the wider end thereof and into passage entrance 116a, out of passage exit 116b and between the two cylinders 108, 110 to passage exit 112a. When the side of suture tag 106 having passage 112a, for example, is adjacent the tissue, by pulling on the opposite portion of suture 70, in this case, the portion that extends from passage 112b, the inner tapered cylinder 110 is pulled out of the outer tapered cylinder 108 allowing the suture to be pulled through until the tissue to be ligated is compressed to the desired degree. By applying a tension force on the portion of suture 70 that extends from the passage at 112a, tapered cylinder 110 is pulled into the outer cylinder 108, wedging itself against the narrowing taper on the inside surface of outer cylinder 108, and locking the suture 70 to stop any further slipping or sliding movement of the suture through the passages 112, 114 116. As long as the tension of the portion of suture 70 extending from passage 112a is greater than the tension applied to the portion of suture 70 extending from passage 112b, no sliding of the suture 70 will occur, thus providing a one way suture lock. Any suitable means of tying the suture or attaching it to the suture tag 106 will suffice.

[0057] The suture tag 106 may be applied to the suture 70 in a separate step after the forgoing suturing procedure with the suturing apparatus is completed or, it may be placed on the trailing end of the suture 70 and used to cinch suture 70 when the shuttle needle 20 is itself used as a distal suture tag. The suture tag 106 may also be used to cinch both ends of the same suture 70, previously placed in tissue by transferring the suture 70 thru the one-way suture tag 106 using a loop type snare, which is formed by a loop of stiff fiber that is feed through the needle eye. The suture tag 106 may have such a loop pre-installed to allow the surgeon or clinician to place the suture tag 106 onto suture 70 by placing both strands in the loop of the loop type snare and pulling the loop through the tag 106 to drag the suture through the tag 106.

[0058] Instead of a suture tag 106, the shuttle needle 20 alone may be used as a tag and left at the end of the stitching to function as an anchor to secure the stitching.

[0059] The devices disclosed herein may be made of stainless steel, titanium or any biocompatible material or bioabsorbable material. The suture materials used with the suturing apparatus and suture tags are also made of biocompatible or bioabsorbable materials. The devices disclosed herein can be designed to be disposed of after a single use, or they can be designed to be used multiple times. In either case, however, the device can be reconditioned for reuse after at least one use. Reconditioning can include any combination of the steps of disassembly of the device, followed by cleaning or replacement of particular pieces, and subsequent reassembly. In particular, the device can be disassembled, and any number of the particular pieces or parts of the device can be selectively replaced or removed in any combination. Upon cleaning and/or replacement of particular parts, the device can be reassembled for subsequent use either at a reconditioning facility, or by a surgical team immediately prior to a surgical procedure. Those skilled in the art will appreciate that reconditioning of a device can utilize a variety of techniques for disassembly, cleaning/replacement, and reassembly. Use of such techniques, and the resulting reconditioned device, are all within the scope of the present invention.

[0060] Preferably, the various embodiments of the invention described herein will be processed before patient use. First, a new or used instrument, in this case, the suturing apparatus 10 is obtained and if necessary cleaned. The suturing apparatus 10 can then be sterilized by any suitable known sterilization technique. This can be done by any number of ways known to those skilled in the art including beta or gamma radiation, ethylene oxide, steam. In one sterilization technique, the suturing apparatus 10 is placed in a closed and sealed container, such as a plastic or TYVEK bag. The container and instruments are then placed in a field of radiation that can penetrate the container, such as gamma radiation, x-rays, or high-energy electrons. The radiation kills bacteria on the instruments and in the container. The sterilized instruments can then be stored in the sterile container. The sealed container keeps the deployment device and anchors sterile until it is opened in the medical facility.

[0061] In summary, numerous benefits are apparent which result from employing the concepts of the invention. The foregoing description of one or more embodiments of the invention has been presented for purposes of illustration and description. It is not intended to be

exhaustive or to limit the invention to the precise form disclosed. Obvious modifications or variations are possible in light of the above teachings. The embodiments were chosen and described in order to best illustrate the principles of the invention and its practical application to thereby enable one of ordinary skill in the art to best utilize the invention in various embodiments and with various modifications as are suited to the particular use contemplated. It is intended that the scope of the invention be limited only by the claims appended hereto.

Claims:

1. A surgical suturing apparatus comprising:

a channel having a longitudinal axis, a distal end and a proximal end, said channel defining a housing at the distal end thereof having an opening therein;

a needle releasably disposed within said housing, said needle having a first end and a first puncturing point at a second end, said needle being structured for attachment to a length of suture material;

a needle positioning assembly having members movable relative to said channel for effecting a desired number of release and retrieval cycles for releasing said needle from said housing and guiding the return of said needle to said housing; and

an actuation assembly for controlling said members of said needle positioning assembly.

2. The surgical suturing apparatus recited in claim 1 wherein said actuation assembly further comprises:

a body portion;

a handle;

a plurality of rods operatively connected to said members of said positioning assembly for controlling movement of said needle.

3. The surgical suturing apparatus recited in claim 1 further comprising a length of suture material attached to said needle such that the puncture of tissue with said first puncturing point and movement of said needle through said tissue in a first direction threads said suture material through said tissue.

4. The surgical suturing apparatus recited in claim 1 wherein said first end of said needle forms a second puncturing point and said channel is open at the distal end thereof to expose said

second puncturing point for puncturing tissue in a first direction when said channel is moved in said first direction.

5. The surgical suturing apparatus recited in claim 1 wherein needle positioning assembly comprises:

an engagement member configured for releasably engaging said needle to effect axial movement of said needle within said channel;

a ramp member movable axially within said channel and configured for operative contact with said needle for effecting movement of said needle to a first stage of progression adjacent said opening of said housing and to a second stage of progression wherein at least said first puncturing point is out of said housing; and

a movable snare member having a portion configured for engagement with said needle for guiding said needle when said needle is out of said housing.

6. The surgical suturing apparatus recited in claim 5 wherein said needle has a first engagement surface adjacent said first end and a second engagement surface adjacent said first puncturing point.

7. The surgical suturing apparatus recited in claim 6 wherein said portion of said snare member further comprises:

a noose for engagement with said second engagement surface of said needle;

an expandable loop proximal to said noose, said loop being biased away from the longitudinal axis of said channel; and

an elongate section proximal to said loop and operatively connected to said actuation assembly, wherein movement of said elongate section in said distal direction positions said noose and loop adjacent said opening of said housing to enable the release of said loop and noose from

said channel and movement in said proximal direction when said noose and loop are out of said channel effects the return of said loop and said noose to said channel.

8. The surgical suturing apparatus recited in claim 6 wherein said ramp member comprises:

a rail operatively connected to said actuation assembly at a proximal end of said rail; and,

a slope at a distal end of said rail for contact with said needle.

9. The surgical suturing apparatus recited in claim 8 wherein said slope, when moved into the second stage of progression, urges said needle from said housing at an angle to position said first puncturing point at a desired location for puncturing tissue.

10. The surgical suturing apparatus recited in claim 6 wherein said engagement member comprises an elongate portion operatively connected to said actuation assembly and a pair of tines for engaging said needle at said first engagement surface.

11. The surgical suturing apparatus recited in claim 5 wherein said actuation assembly further comprises:

a body portion;

a handle;

a first push rod housed in said body portion and being operatively connected to said handle and said engagement member for driving axial movement of said engagement member;

a second push rod housed in said body portion and being operatively connected to said handle and said ramp member for driving axial movement of said ramp member to said first stage of progression and for driving movement of said ramp member in said second stage of progression;

a lock mechanism for locking said second push rod against movement of said ramp member to said second stage of progression;

a release mechanism for selectively unlocking said second push rod to trigger movement of said ramp member to said second stage of progression; and

a third push rod housed in said body portion and being operatively connected to said handle and said snare member for driving axial movement of said snare member to a position for release of said portion of said snare from said channel and for return of said portion to said channel.

12. The surgical suturing apparatus recited in claim 11 wherein movement of said third push rod in a distal direction positions said portion of said snare member within an opening in said housing to effect the release of said portion of said snare member for engagement with said needle, and movement of said third push rod in a proximal direction when said portion engages said needle effects (i) the proximal travel of said needle when said needle is out of said housing to pull said needle through tissue in said proximal direction and (ii) the return of said portion of said snare member and said needle to said channel.

13. The surgical suturing apparatus recited in claim 12 wherein said actuation assembly further comprises a trigger for moving said snare portion distally to said opening in said housing.

14. The surgical suturing apparatus recited in claim 11 wherein said lock mechanism comprises a pin extending outwardly from said second push rod, and a locking plate having a notch therein for stopping said pin against movement in a distal direction beyond said notch.

15. The surgical suturing apparatus recited in claim 14 wherein said release mechanism comprises a lever for lifting said locking plate to release said pin from said notch.

16. The surgical suturing apparatus recited in claim 1 further comprising at least one suture tag, each having passages therethrough for attachment to the suture material, said suture tags being configured for attachment at one or both ends of the length of suture for securing the suture to said tissue.

17. The surgical suturing apparatus recited in claim 16 wherein the suture tag comprises an outer tapered cylinder and an inner tapered cylinder within said outer cylinder, each said cylinder having at least one passage therethrough for passage of the suture material.

18. A suture anchor comprising an outer cylinder and an inner cylinder axially movable within said outer cylinder, each said cylinder having at least one passage therethrough for passage of suture material therethrough.

19. The suture anchor recited in claim 18 wherein the outer cylinder has a tapered inner surface and the inner cylinder has a tapered outer surface complementary locking engagement with the tapered inner surface of the outer cylinder to lock the suture material in a desired position.

20. A method of suturing comprising:

directing a surgical instrument to a tissue site in need of suturing, wherein the surgical instrument comprises:

a channel having a longitudinal axis, a distal end and a proximal end, said channel defining a housing at the distal end thereof having an opening therein;

a needle releasably disposed within said housing having a first end thereof, a first puncturing point at a second end thereof;

a length of suture material attached to said needle;

a needle positioning assembly having members movable relative to said channel for effecting a desired number of release and retrieval cycles for releasing said needle from said housing and guiding the return of said needle to said housing; and

an actuation assembly for controlling said members of said needle positioning assembly;

actuating said actuation assembly to:

position said needle for release from said housing;

engage said first end of said needle within said housing;

release said second end of said needle from said housing;

release one of said needle positioning members from said channel;

move said channel toward said site in need of suturing;

release said first end of said needle and move said first puncturing point of said needle through said tissue to puncture said tissue at said site;

engage said second end of said needle as it passes through said puncture site with said released needle positioning member;

draw said released needle positioning member into said channel to pull said needle and a portion of said suture material through said puncture site;

draw said released needle positioning member further into said channel to return said needle to said housing; and,

re-position said needle for release from said housing; and,

repeating said actuating steps for a desired number of release and retrieval cycles to suture said tissue.

21. The method recited in claim 20 wherein said step of directing a surgical instrument to said site in need of suturing comprises directing said channel through said tissue at said site in a first direction of puncture and said step of actuating said actuation assembly to move said first puncturing point of said needle through said tissue comprises moving said first puncturing point of said needle through said tissue in a second direction at an adjacent site to provide a stitch.

22. The method recited in claim 21 wherein said step of repeating said actuating steps comprises repeating the steps of directing said channel through said tissue at successive sites in said first direction and moving said first puncturing point of said needle through said tissue at successive sites in said second direction to provide multiple stitches.

23. The method recited in claim 20 wherein said step of directing a surgical instrument to said site in need of suturing comprises directing said channel to a site adjacent tissue in need of suturing and said step of actuating said actuation assembly to move said first puncturing point of said needle through said tissue comprises moving said first puncturing point of said needle through said tissue at said site in a first direction of puncture and said step of repeating said actuating steps comprises repeating the steps of directing said channel to successive adjacent sites of tissue in need of suturing and moving said first puncturing point of said needle through said tissue at said successive sites in said first direction to provide multiple stitches.

24. The method recited in claim 20 further comprising attaching at least one suture tag to the length of suture material and positioning said suture tag at one or both of the initial puncture site and a final puncture site to secure the suture to the tissue.

25. A method comprising:

obtaining a surgical instrument, wherein the surgical instrument comprises:

a channel having a longitudinal axis, a distal end and a proximal end, said channel defining a housing at the distal end thereof having an opening therein;

a needle releasably disposed within said housing, said needle having a first end and a first puncturing point at a second end, said needle being structured for attachment to a length of suture material;

a needle positioning assembly having members movable relative to said channel for effecting a desired number of release and retrieval cycles for releasing said needle from said housing and guiding the return of said needle to said housing; and

an actuation assembly for controlling said members of said needle positioning assembly;

sterilizing the surgical instrument; and

storing the surgical instrument in a sterile container.

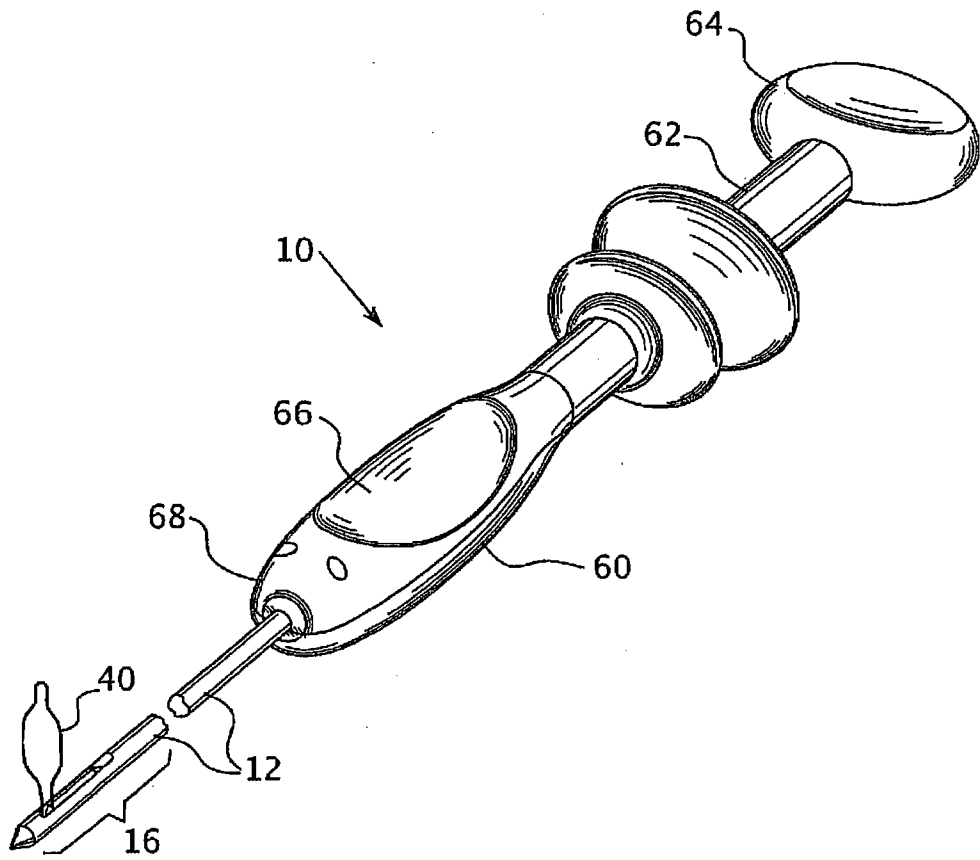

FIG. 1

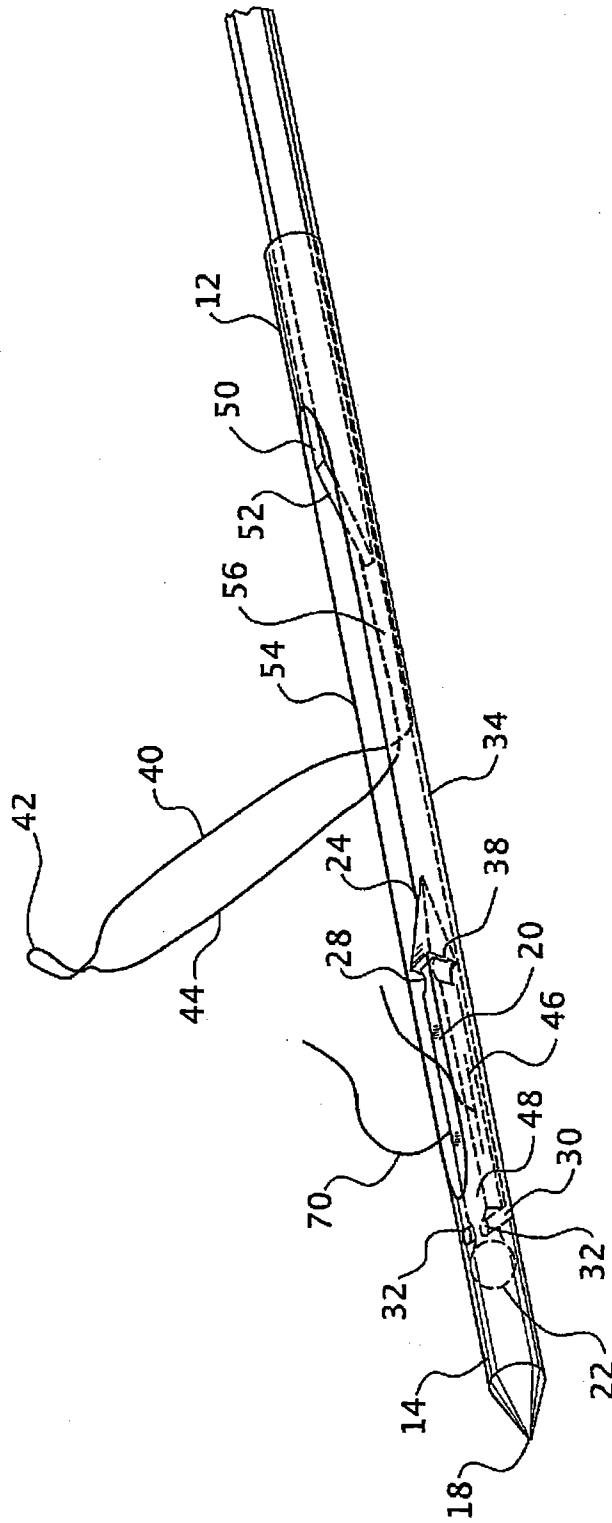

FIG. 2A

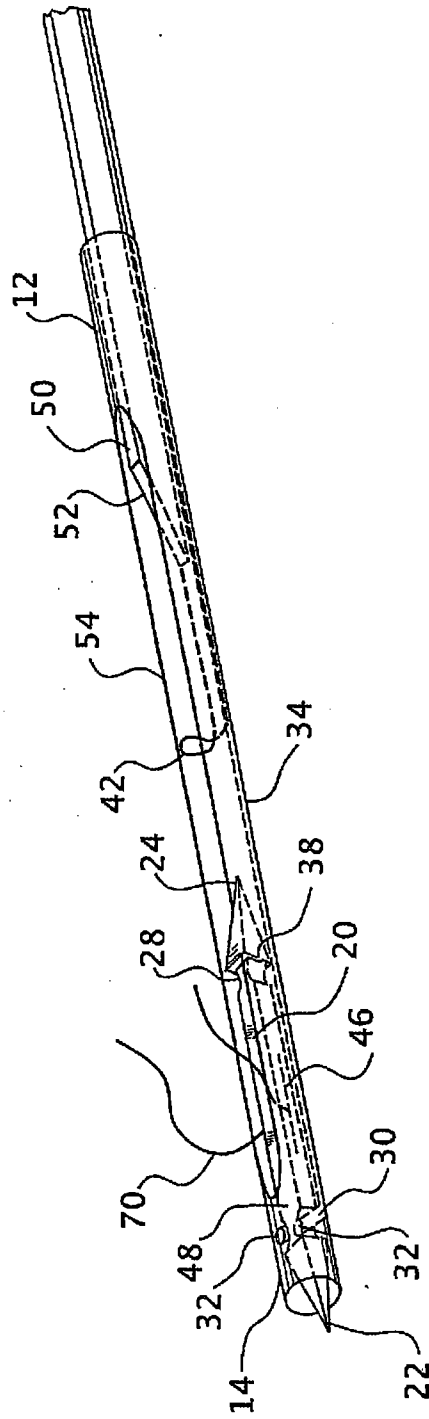

FIG. 2B

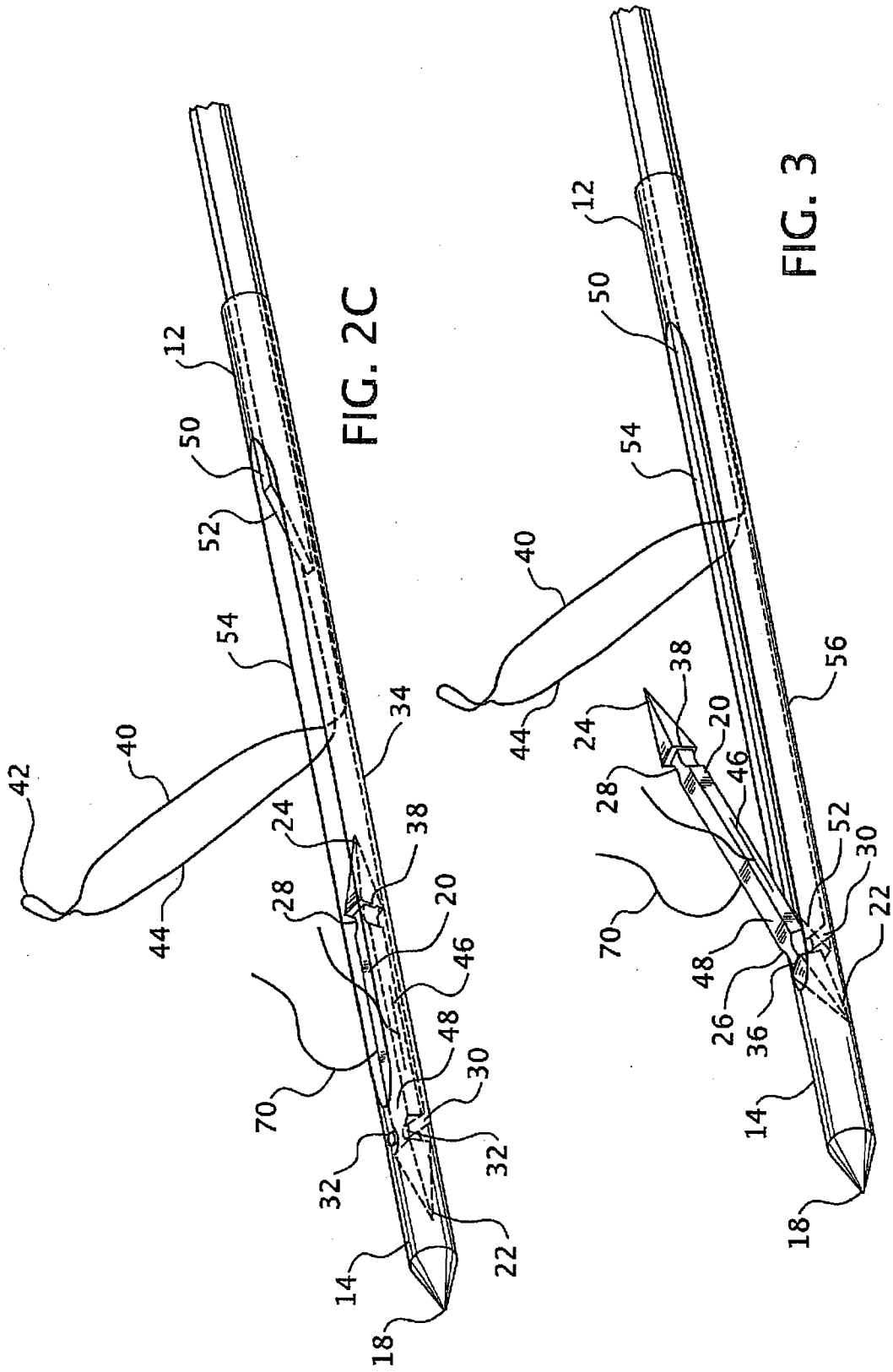

FIG. 2C

FIG. 3

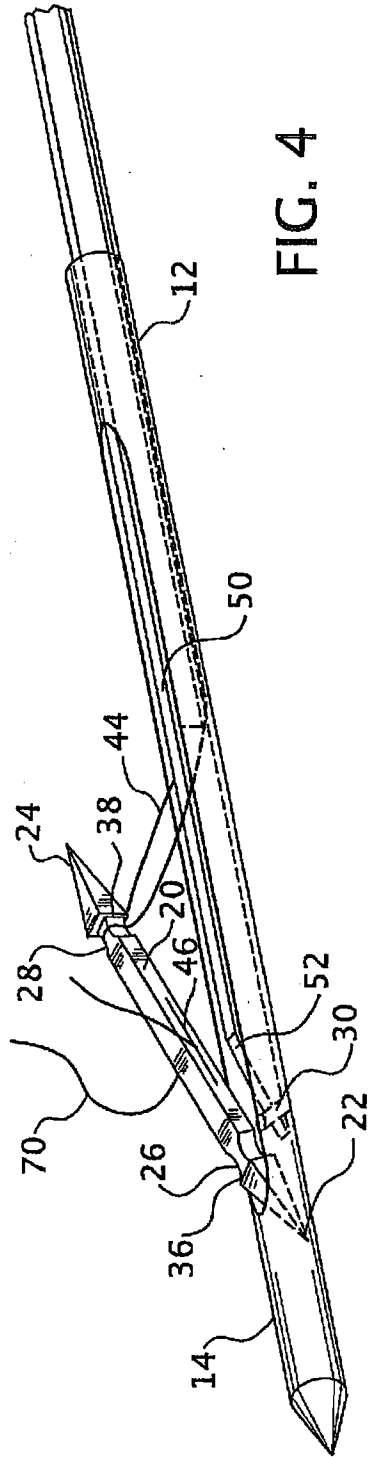

FIG. 4

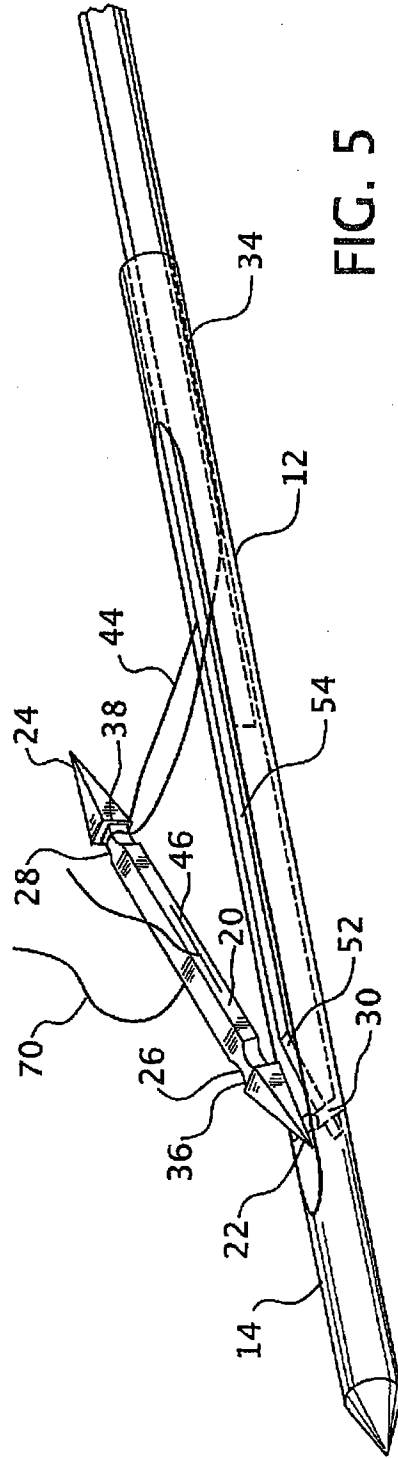

FIG. 5

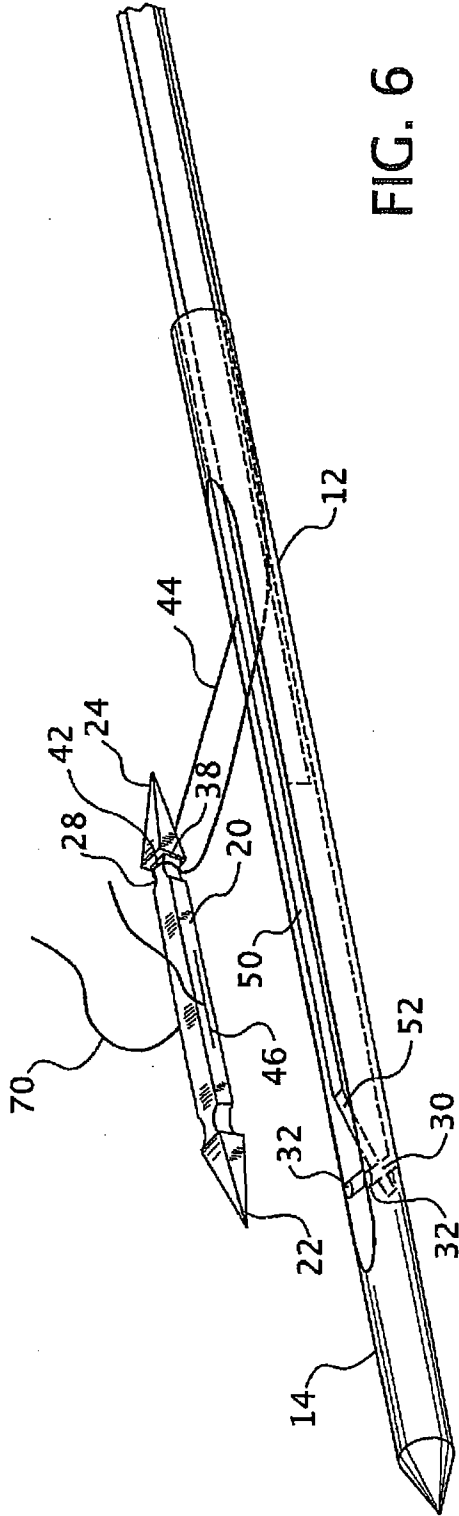

FIG. 6

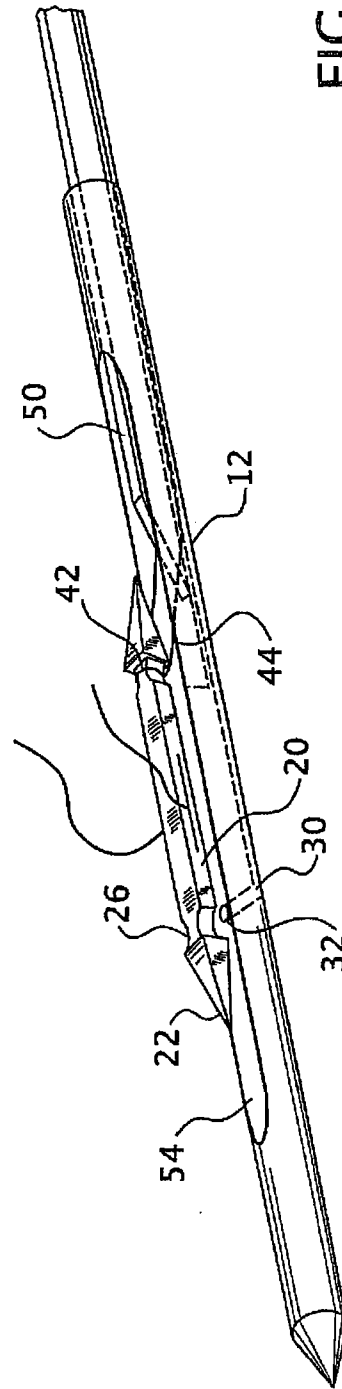

FIG. 7

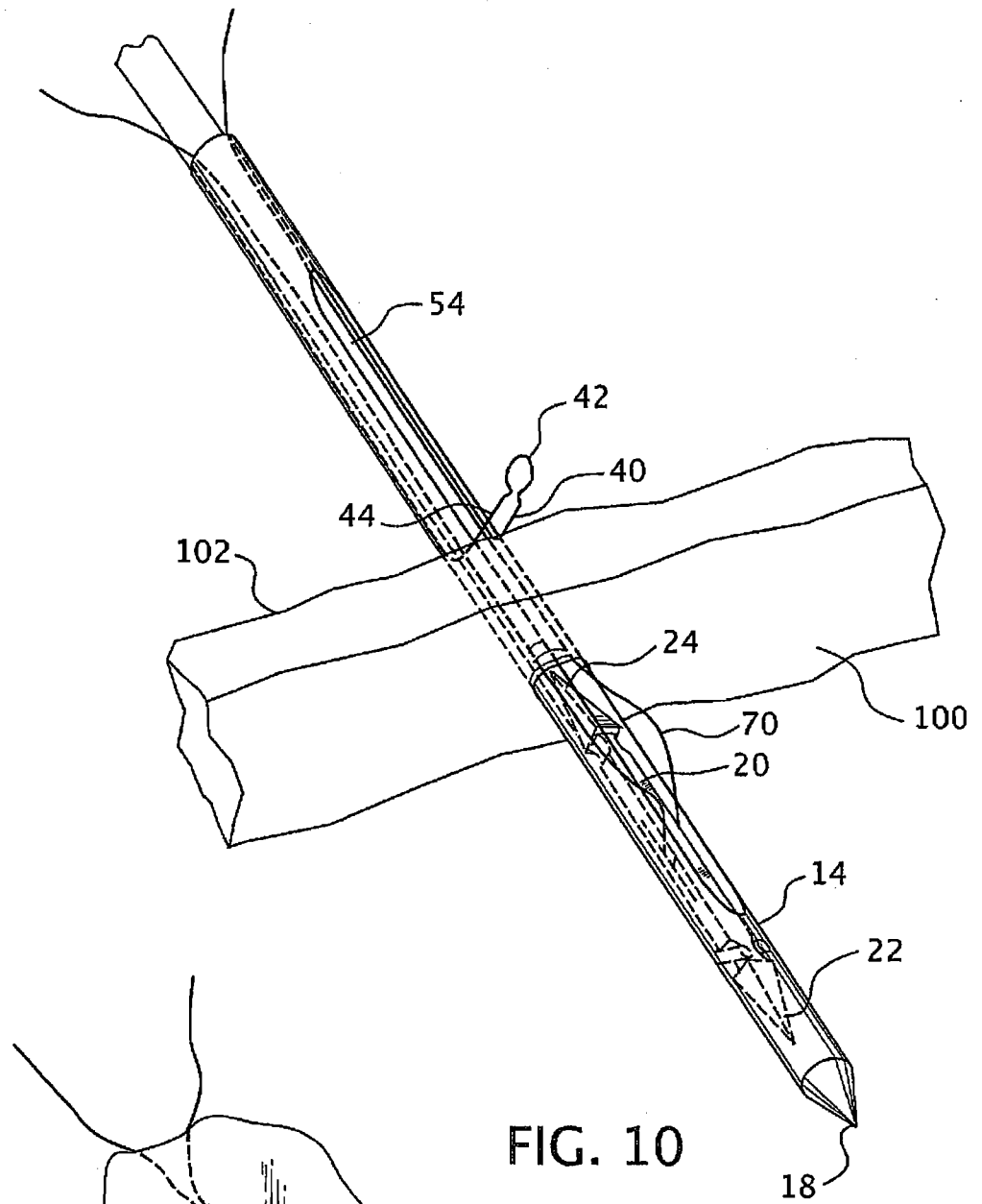

FIG. 10

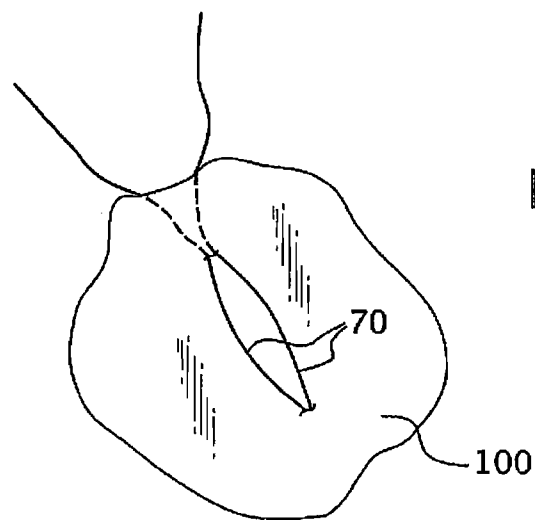

FIG. 11

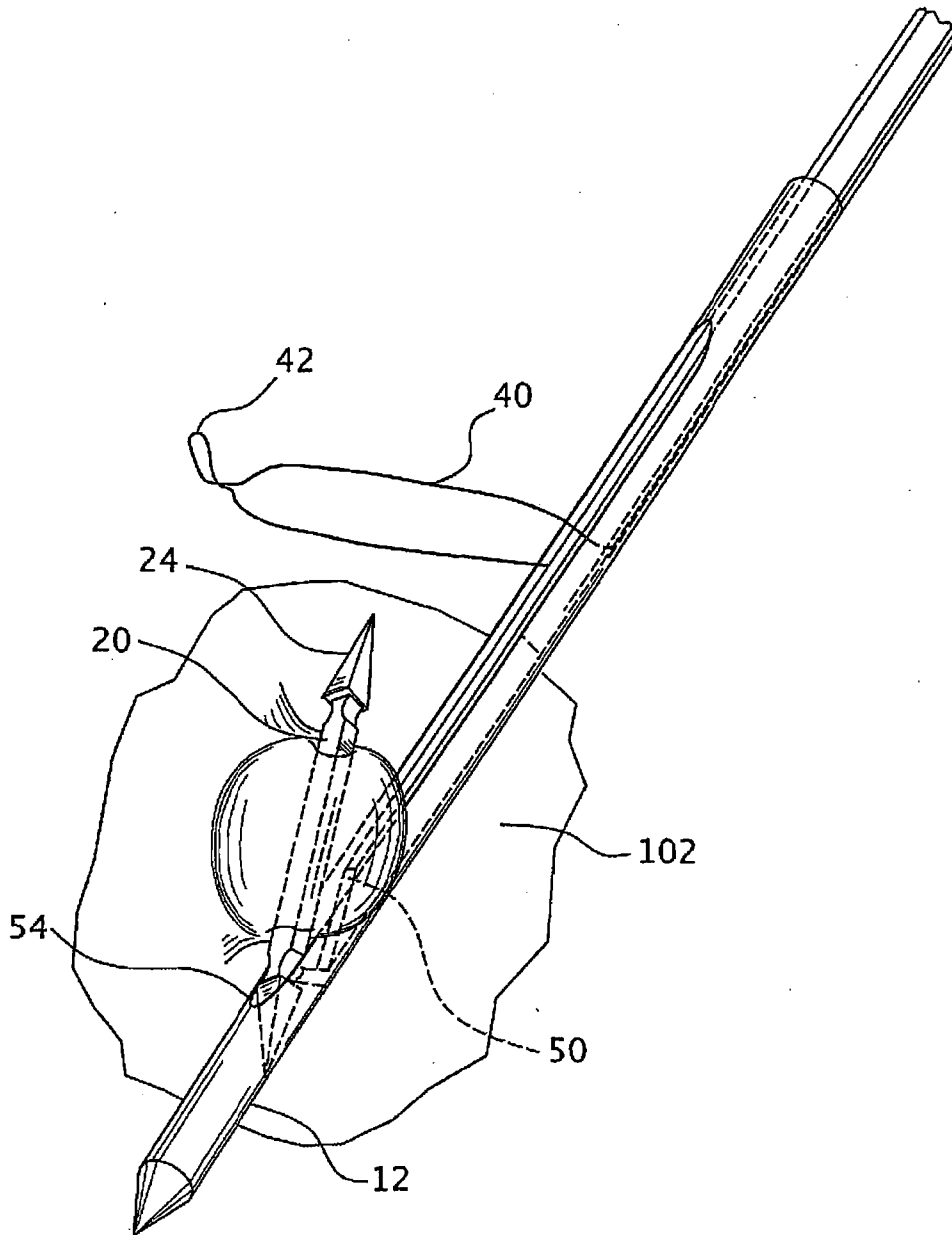

FIG. 12

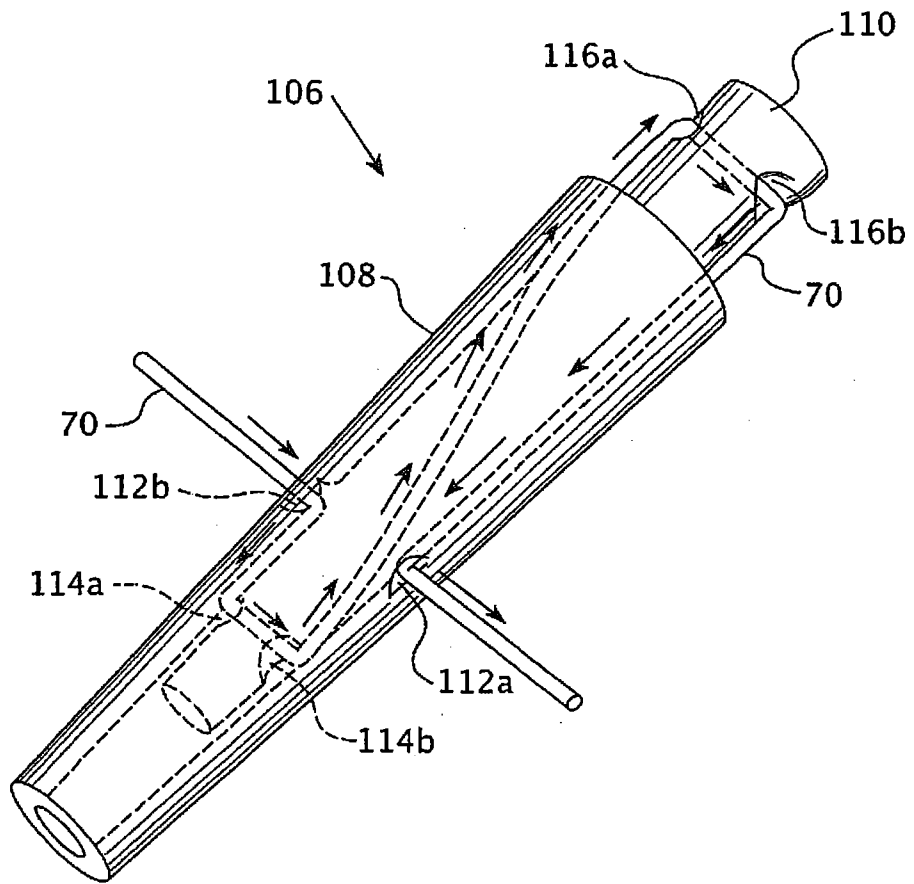

FIG. 13

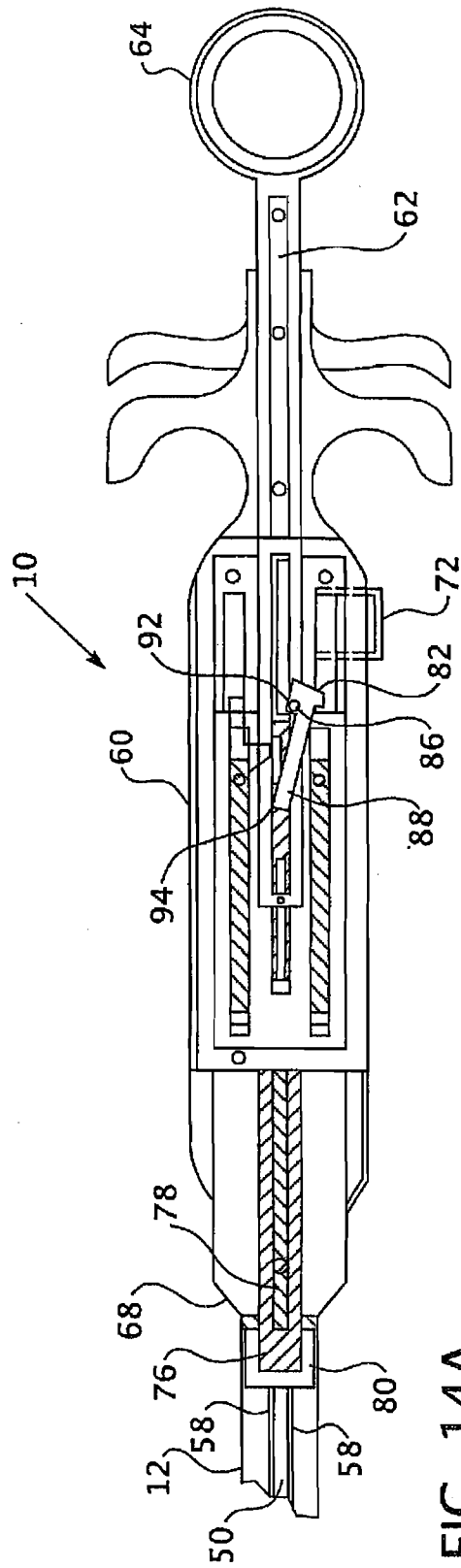

FIG. 14A

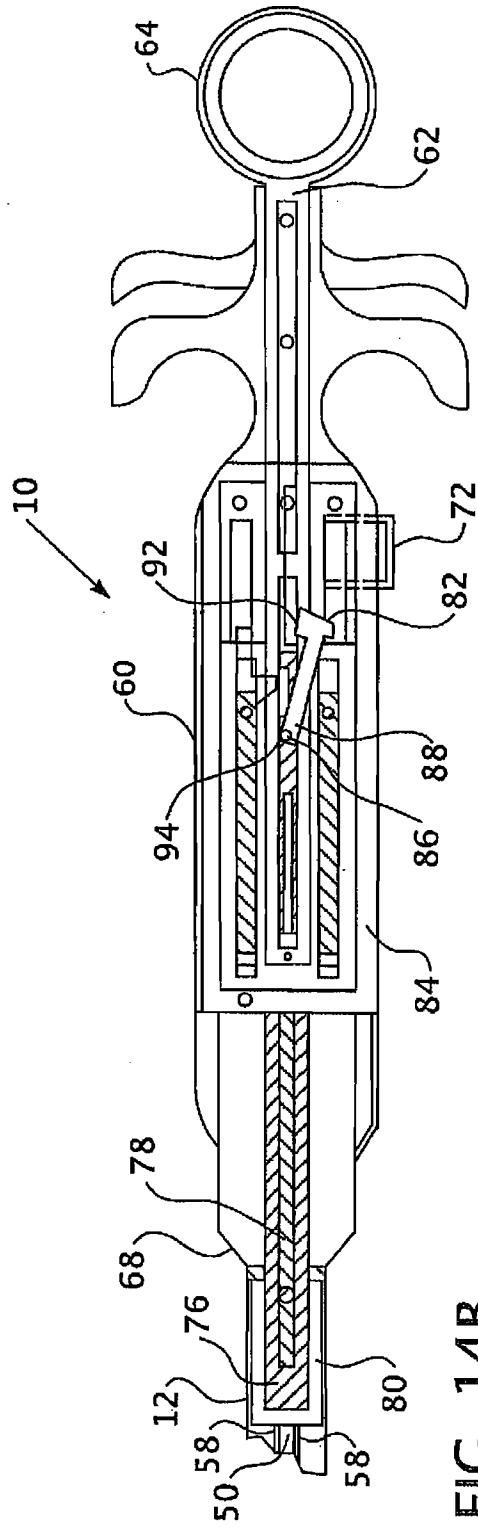

FIG. 14B

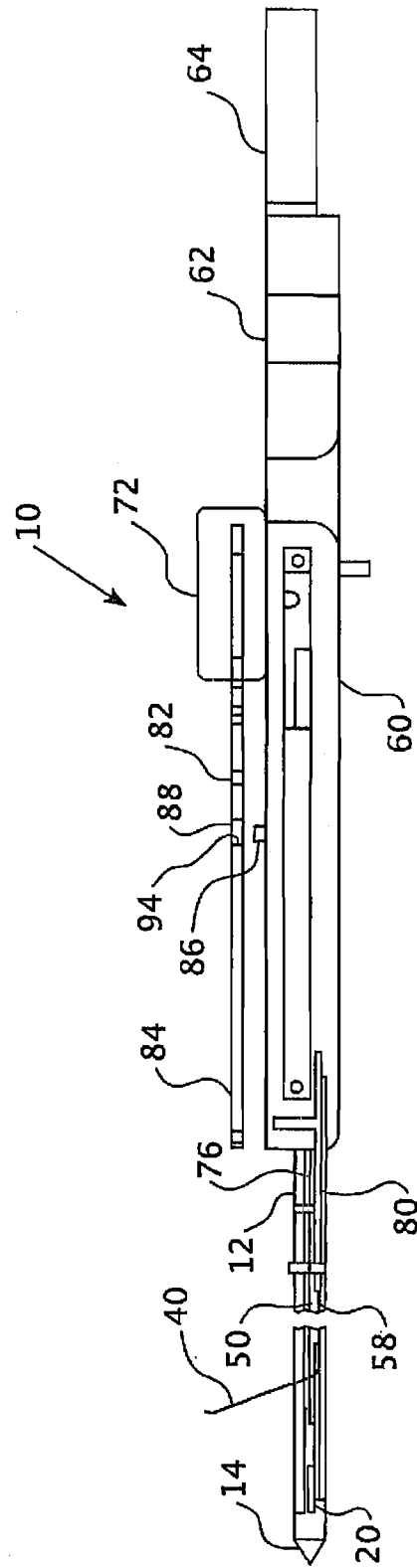

FIG. 15