

(19)



(11)

**EP 2 063 123 A2**

(12)

**EUROPEAN PATENT APPLICATION**

(43) Date of publication:  
**27.05.2009 Bulletin 2009/22**

(51) Int Cl.:  
**F04B 43/073** (2006.01) **F04B 47/00** (2006.01)  
**F04B 47/02** (2006.01) **F04B 53/12** (2006.01)  
**E21B 43/00** (2006.01)

(21) Application number: **08171827.2**

(22) Date of filing: **05.12.2005**

(84) Designated Contracting States:  
**AT BE BG CH CY CZ DE DK EE ES FI FR GB GR HU IE IS IT LI LT LU LV MC NL PL PT RO SE SI SK TR**

(72) Inventor: **Sagov, Magomet**  
**3320, Vestfossen (NO)**

(30) Priority: **09.12.2004 NO 20045382**

(74) Representative: **TBK-Patent**  
**Bavariaring 4-6**  
**80336 München (DE)**

(62) Document number(s) of the earlier application(s) in accordance with Art. 76 EPC:  
**05814040.1 / 1 859 167**

Remarks:  
This application was filed on 16-12-2008 as a divisional application to the application mentioned under INID code 62.

(71) Applicant: **Clavis Impulse Technology AS**  
**N-3301 Hokksund (NO)**

(54) **Method and apparatus for transporting fluid in a conduit**

(57) An apparatus for transporting fluid comprises a conduit (3), at least one fluid dividing means (5) such as a check valve or a semi-permeable membrane which divides the conduit (3) into an upstream side and a downstream side, and an oscillator (8) for moving the fluid dividing means (5). The fluid dividing means (5) in a first state prevents fluid communication between the upstream side and the downstream side and in a second

state allows fluid communication between the upstream side and the downstream side. The fluid dividing means (5) is arranged in a piston (7') which is connected to the oscillator (8) for being imparted with a translational oscillating motion which causes the fluid dividing means (5) to be alternately brought into the first state and the second state so that an incremental fluid volume flows from the upstream side of the fluid dividing means (5) to the downstream side of the fluid dividing means (5).

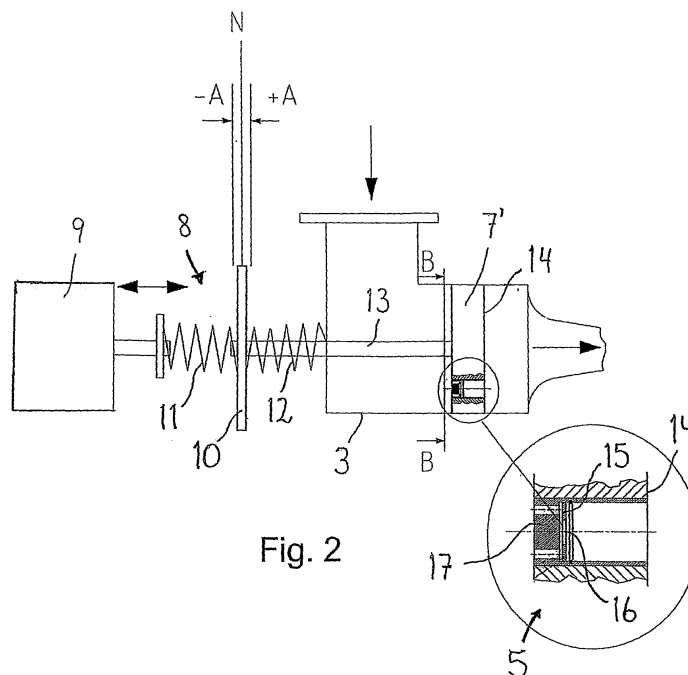

Fig. 2

**EP 2 063 123 A2**

## Description

**[0001]** The present application relates to a method and an apparatus for transporting fluid in a conduit, for example a pipe, as disclosed respectively in the preamble of independent claims 1 and 6.

**[0002]** Pump technology has evolved very little since Archimedes' time. Indeed, all known pumps are based on the same main principle and, put simply, they work by either pushing or pulling (i.e. sucking) the fluid. The previously known pumps thus generate a static pressure which, when the fluid is pushed, diminishes downstream in the pumping direction and, if the transport distance is sufficiently long, will ultimately reach zero at one point, which means that the fluid cannot be transported past this point without, for example, another pump being connected before this point is reached.

**[0003]** In about 1594, Galileo Galilei invented a pump which basically can be termed a syringe. In this connection, he noticed that it was impossible to draw water up from a depth of more than about 10 metres. Galileo could not explain the reason for this limitation, but this phenomenon has since been explained and in hydraulic engineering today it is acknowledged that the theoretical 10-metre boundary line cannot be crossed. In practice, due to various effects (for example, friction), the suction lift limit is less than about seven metres.

**[0004]** The previously known pumps therefore have clear limitations. The suction lift limit means that in the case of vertical transport of a fluid over large distances towards the surface, for example, in the offshore industry, a pump must be installed on the bottom and additional pumps must be installed in series in the direction of transport. This makes installation and maintenance difficult, and since the entire weight of the fluid column is lifted during pumping, an enormous amount of energy is required to pump the fluid when the transport distances involved are long. The drawbacks of the previously known pumps are therefore the aforementioned suction lift limit, low efficiency and high energy consumption.

**[0005]** To avoid the aforementioned drawbacks of the prior art, there is according to the invention provided a method and an apparatus as disclosed respectively in the characterising clause of claims 1 and 6.

**[0006]** Advantageous embodiments of the invention are set forth in the dependent claims.

**[0007]** Unlike previously known pumps, the fluid is not pushed or sucked in the conventional manner when using the apparatus or method according to the invention. Instead, in a preferred embodiment, mechanical impulses or pressure waves are introduced into the fluid in a pipe. In a sense, the apparatus, or the pump, acts as a hammer, generating acoustic waves (or pressure waves) in the system. The waves travel through the fluid in the pipe at the speed of sound and with very little dissipation.

**[0008]** Acoustic waves are large pressure oscillations, and when a wave encounters a valve, the valve remains closed while the pressure difference across the valve is

positive (i.e. pressure above atmospheric), and opens when the pressure difference becomes negative (i.e., pressure below atmospheric) in response to the wave being reflected by the valve, thus creating a flow through the valve in the direction of the negative pressure in order to equalise the pressure across the valve. The valve generates the suction effect, and energy is supplied to the valve through the fluid. In other words, the fluid carries potential energy in the form of acoustic waves, and a main function of the valve is to transform this energy into kinetic energy, after which the fluid volume that has flowed through the valve in response to the wave's activation thereof is transported in the form of a compression wave which travels through the fluid. The fluid transport, or pumping, thus takes place according to the invention in that each small or incremental fluid volume that flows through the valve is transported downstream through the rest of the fluid in the form of a pressure wave of increased volume density.

**[0009]** With the apparatus and method according to the invention there is probably no suction lift limit. A successful test with a vertical suction height of 24 metres (which is more than three times the previously known conventional, practical suction lift limit) has been conducted, the suction height being chosen on the basis of the maximum vertical pipe length the test facility allowed. The experiment shows that the invention is a major breakthrough in the domain of fluid transport, and the new technology according to the invention will be even more efficient when the pipe is placed in water, due to the hydrostatic balance between the inside and the outside of the pipe. Such conditions are usual in oil extraction where deep sea pumping is required.

**[0010]** The parts of the apparatus, or the pump, according to the invention which constitute the wave generator may advantageously be positioned on top of a fluid source, for example, an oil well, and thus positioned will contribute to a dramatic reduction in installation and maintenance costs in addition to a substantial reduction in energy consumption.

**[0011]** Only the part of the device which constitutes the fluid dividing means, preferably a check valve, will be arranged at the fluid transport starting point, which often means at the bottom of the fluid source. A check valve of this kind will be relatively easy to put in place, and does not require any external energy supply apart from the energy supplied through the fluid in the form of waves. The wave generator will thus be the part of the apparatus that requires external energy supply via power cables, hydraulic lines, mechanical transmissions or the like.

**[0012]** During time-consuming maintenance and repair work, the wave generator can be temporarily replaced by a new one, thereby allowing continuous operation. The apparatus and the method according to the invention will thus result in reduced total costs, which will always be a major objective in oil production.

**[0013]** The apparatus, or the pump, according to the invention is highly efficient, and its efficiency has been

measured to be up to 95%. The transport material may be liquids, gases, multiphase fluids or highly viscous fluids. Successful tests have also been conducted with a non-Newtonian fluid.

**[0014]** With the apparatus and method according to the invention, it is anticipated that it will be possible to extract oil from oil fields which cannot be extracted today using conventional pumps due to high costs or quite simply because it is technically impossible.

**[0015]** The method and apparatus according to the invention will be described in more detail below on the basis of advantageous, non-limiting exemplary embodiments, and with reference to the accompanying drawings and appended claims, wherein:

Figure 1 is a simplified diagram of a first embodiment of the apparatus according to the invention used for vertical transport of a fluid from a lower to an upper fluid reservoir;

Figure 2 is a simplified diagram of a second embodiment of the apparatus according to the invention, and includes an enlarged detailed view of a part of the apparatus;

Figure 3 is a sectional view of the apparatus shown in Figure 1 along the line B - B;

Figure 4 is a graph of the oscillatory motion of the apparatus shown in Figures 1, 2 and 3;

Figure 5 is a graph of pressure measurements made during a test of the apparatus according to the invention; and

Figure 6 is a graph of pressure measurements made during another test of an apparatus according to the invention.

**[0016]** In the description and the claims, the terms "upstream" and "downstream" are related to the direction of fluid transport or pumping direction, as should be implicitly apparent.

**[0017]** Figure 1 shows a first embodiment of the apparatus according to the invention, where fluid is transported from a lower 1 to an upper 2 fluid reservoir through a pipe 3, and comprising a wave generator 4 and a fluid dividing means in the form of a check valve 5 located at a lower end of the pipe 3 submerged in the reservoir 1. Another check valve 6 is shown located downstream of the wave generator 4. This check valve 6 may have a stabiliser function, serve as a regulator of several parameters depending on the structure of the fluid transport system, or alternatively be omitted. In the figure, the direction of fluid transport is indicated by solid arrows, whilst the direction of travel of a wave generated by the wave generator 4 is indicated by a stippled arrow. The check valves 5, 6 are basically constructed in that spring-

loaded balls lie sealingly against respective valve seats, as will readily be apparent to a person of skill in the art. When a wave from the wave generator hits the one-way valve 5 and is reflected upwards (concurrently), the check valve will open in order to then be closed again because of the pressure difference that occurs across the valve as a result of the wave, as explained above. An incremental fluid volume  $\Delta V$  will then flow concurrently through the valve 5, and travel in the form of a pressure wave through the fluid in the pipe 3 on the downstream side of the valve 5 to the upper fluid reservoir 2.

**[0018]** With regard to the initial conditions for the fluid transport system comprising the apparatus according to the invention, there may initially be air on the whole or part of the downstream side of the check valve 5 and liquid on the upstream side of the check valve. A wave formed by the wave generator 4 will travel first through the air and then through the liquid on the downstream side of the check valve 5 before the valve is activated by the wave to admit an incremental liquid volume  $\Delta V$ . Thus, for each generated wave, the pipe 3 will be successively filled with liquid, and after sufficiently many generated waves liquid will flow out of the pipe 3 and to the upper fluid reservoir 2. Therefore, the wave generator 4 does not initially need to generate a wave directly in liquid in order to cause liquid to be transported from the lower 1 to the upper 2 fluid reservoir, as the wave can be transmitted between different fluids in gas and liquid state.

**[0019]** The wave generator 4 consists of the following main components: a membrane 7, an oscillator 8 and a vibrator or power source 9. The basic mode of operation of the wave generator 4 will be explained in more detail below with reference to Figures 2 and 3, which show a second embodiment of the invention in which the wave generator and fluid dividing means - unlike in the first embodiment shown in Figure 1 - constitute an integral unit in that a plurality of check valves 5 are arranged in a piston 7'.

**[0020]** In Figure 2, the power supplying motion of the power source 9 is indicated by a double arrow, whilst the direction of fluid transport through the pipe 3 is indicated by regular arrows. The oscillator 8 includes an oscillating weight 10 disposed between a first end of two coil springs 11 and 12, and connected to the piston 7' via a shaft 13. A second end of the coil spring 12 is rigidly supported, and a second end of the coil spring 11 is connected to the vibrator or power source 9 which via the coil spring 11 and at a given frequency imparts to the oscillating weight 10 a translational oscillating motion of an amplitude of A about a neutral point N. Thus, the oscillating weight 10 will, together with the coil springs 11 and 12, form a part of an oscillating system having a given resonant frequency, and the motion of the oscillating weight 10 will be transmitted to the piston 7' via the shaft 13.

**[0021]** The oscillating weight 10 and the piston 7' will thus oscillate at an amplitude A at a given frequency, and it will be apparent to those skilled in the art that a small amplitude, for example in the range of 5 mm, and high

frequency, for example in the range of 100 Hz, will cause a high acceleration which in turn will cause the fluid on the downstream side of the piston 7' to be supplied with a high power impulse from the piston 7'. Furthermore, the potential energy and kinetic energy of the oscillating system, minus the energy losses in the system, will always be constant, the losses here consisting mainly of

**[0022]** The enlarged detailed view in Figure 2 shows the structure of the check valves 5 more clearly. Each valve is arranged as a through opening in the piston 7' perpendicular to the piston 7' surface 14. A membrane 15 with a central orifice 16 is provided in the through opening. A central abutment element 17 for the membrane 15 is also provided, so that a part of the membrane 15 will be moved into sealing contact with the abutment element by the positive pressure formed on the downstream side of the valve 5 when the piston moves in the downstream direction. Fluid flow through the valve 5 will thus be prevented. Conversely, when the piston 7' moves in the upstream direction, it will be apparent to those skilled in the art that fluid flow through the valve 5 can take place unimpeded. When the piston 7' moves in the upstream direction, an incremental fluid volume  $\Delta V$  will thus flow through the open valves 5 in the piston 7' to the downstream side. When the piston then changes direction of travel, the valves 5 will close and the incremental fluid volume  $\Delta V$  is transported in the form of a pressure wave formed by the motion of the piston 7' and which travels in the fluid on the downstream side of the piston 7'. Because the valves 5 are open when the piston 7' moves counter-flow, the motion resistance of the piston in this direction will be small, and it may therefore be more descriptive to say that the incremental fluid volume  $\Delta V$  is "captured" on the downstream side of the piston during the counter-flow motion of the piston 7' than that the incremental fluid volume  $\Delta V$  flows through the valve, as the pressure difference across the piston 7' will be small during the counter-flow motion of the piston 7'.

**[0023]** In Figure 4, the translational oscillating motion of the oscillating system or oscillator 8 is graphically presented in the form of a sine curve as a function of time, and where the aforementioned losses consist of an amplitude decrement D between two successive oscillations. The work required to create oscillations of the same amplitude is supplied to the oscillator 8 from the power source 9.

**[0024]** As mentioned above, various tests of the apparatus and method according to the invention have been conducted in which the theoretical suction lift limit for the conventional pumps known to date has been exceeded.

**[0025]** Figure 5 shows a graph of pressure measurements as a function of time made at two different points in a pipe during a suction lift test of one embodiment of the apparatus according to the invention which is essentially identical to the embodiment shown in Fig. 1, and where, as previously mentioned, a suction lift height of 24 metres was obtained. From the figure it can be seen

that, as expected, there is a phase displacement between the pressure waves (represented by the peaks in the figure) by the apparatus (i.e., at a reference height equal to zero metres) and the pressure waves 16 metres upstream in the pipe from the said reference height (i.e., lower than the apparatus), as the pressure waves moves through the fluid at a given wave velocity. More surprisingly, it can be seen from the figure that the pressure waves are in fact also intensified as the pressure 16 metres upstream in the pipe is considerably higher than at the said reference height. From wave physics, it is generally known that waves travel more easily in a denser or more compressed medium, and the explanation of the aforementioned phenomenon is believed to reside in the fact that the static pressure, and thus also the density, of a fluid generally increases with increasing depth in the fluid, and that the wave is intensified because it travels through a medium having steadily increasing pressure and density.

**[0026]** Figure 6 is a graph of pressure measurements made during a test of another, small-scale embodiment of an apparatus according to the invention, essentially like the embodiment shown in Figures 2 and 3, and where the pressure was measured at three different points. The different points were immediately upstream of the apparatus (indicated by a circular symbol), immediately downstream of the apparatus (indicated by a cruciform symbol) and at a greater downstream distance from the apparatus (indicated by square symbol). The figure shows respectively the mean pressure, the maximum pressure and the RMS pressure as a function of frequency, and as can be seen from the figure, the mean pressure, the maximum pressure and the RMS pressure all increase in the downstream direction. Furthermore, the test readings indicate that in particular the maximum pressure and the RMS pressure difference between the measuring points increases with increasing frequency, which is believed to be due to wave superposition.

**[0027]** Instead of the piston 7' with valves 5 shown in Figures 2 and 3, a semi-permeable membrane may alternatively be provided, where fluid can simply flow through the membrane in the downstream direction, and instead of springs 11, 12, other types of energy storing elements may alternatively be provided, for example, closed devices filled with a compressible medium, magnets of the same polarity, resilient materials such a rubber or the like, which have small losses due to inner frictional resistance. Similarly, the power source 9 need not be an electric vibrator as shown in Figure 1, but may be any form of motor or power-generating device which either directly or indirectly produces a translational oscillating motion of a desired frequency and amplitude. In addition, it will be apparent to those of skill in the art that the check valves 5, 6 may be made in many different ways, and that the designs shown in Figures 1-3 are therefore only two of many possible embodiments known *per se*. Finally, although in the exemplary embodiments shown and described in connection with Figures 1-3 a pipe 3 is used,

the pipe 3 may be replaced by any conduit in which at least one wave can travel and an incremental fluid  $\Delta V$  volume can be transported. Consequently, the method and the apparatus according to the invention are not limited by the appended claims.

**[0028]** This application is a divisional application of European patent application no. 05 814 040.1 (the "parent application"), also published under no. EP-A-1 859 167. The original claims of the parent application are repeated below in the present specification and form part of the content of this divisional application as filed.

1. A method for transporting fluid in a conduit (3), for example, a pipe, comprising a fluid dividing means (5) in the conduit which divides the conduit (3) into an upstream side and a downstream side, and which fluid dividing means (5) in a first state prevents fluid communication between the upstream side and the downstream side and in a second state allows fluid communication between the upstream side and the downstream side, characterised by the steps of:

- generating at least one wave in the fluid on the downstream side of the fluid dividing means (5), which wave causes the fluid dividing means (5) to be brought into the second state so that an incremental fluid volume  $\Delta V$  from the upstream side of the fluid dividing means (5) can flow to the downstream side of the fluid dividing means (5); and
- causing a change in pressure on the downstream side of the fluid dividing means (5) when the fluid dividing means (5) is brought back to the first state,

whereby the incremental fluid volume  $\Delta V$  is transported in the form of a pressure wave which travels in the fluid on the downstream side of the fluid dividing means (5).

2. A method according to claim 1, **characterised in that** the step of generating the at least one wave in the fluid on the downstream side comprises moving the fluid dividing means (5) in the fluid.

3. A method according to claim 1, **characterised in that** the step of generating the at least one wave comprises generating the wave at a distance downstream from the fluid dividing means (5).

4. A method according to claim 1, **characterised in that** the step of generating the at least one wave comprises generating a pressure wave.

5. A method according to any one of the preceding claims, **characterised in that** the step of generating the at least one wave in the fluid on the downstream side of the fluid dividing means (5) comprises gen-

erating a plurality of waves using an oscillator (8) and a power source (9).

6. An apparatus for transporting fluid in a conduit (3), for example a pipe, comprising a fluid dividing means (5) in the conduit (3) which divides the conduit (3) into an upstream side and a downstream side, and which fluid dividing means (5) in a first state prevents fluid communication between the upstream side and the downstream side and in a second state allows fluid communication between the upstream side and the downstream side, **characterised in that** a wave generator (4) is provided for generating at least one wave in the fluid on the downstream side of the fluid dividing means (5), which wave causes the fluid dividing means (5) to be brought into the second state so that an incremental fluid volume  $\Delta V$  from the upstream side of the fluid dividing means (5) can flow to the downstream side of the fluid dividing means (5) and cause a change in pressure on the downstream side of the fluid dividing means (5) when the fluid dividing means (5) is brought back to its first state;

whereby the incremental fluid volume  $\Delta V$  is transported in the form of a pressure wave which travels in the fluid on the downstream side of the fluid dividing means (5).

7. An apparatus according to claim 6, **characterised in that** the wave generator (4) comprises an oscillator (8) and a power source (9) for generating a plurality of waves.

8. An apparatus according to claim 6 or 7, **characterised in that** the fluid dividing means (5) is a check valve.

9. An apparatus according to claim 6 or 7, **characterised in that** the fluid dividing means (5) is a semi-permeable membrane.

10. An apparatus according to claim 8, **characterised in that** a plurality of check valves (5) are arranged in a piston (7') or a membrane (7).

11. An apparatus according to one or more of claims 6 to 10, **characterised in that** the wave generator (4) and the fluid dividing means (5) constitute an integral unit.

12. An apparatus according to one or more of claims 6 to 10, **characterised in that** the wave generator (4) is located at a distance downstream of the fluid dividing means (5).

13. An apparatus according to any one of claims 6 to 12, **characterised in that** a check valve (6) is provided downstream of the wave generator (4).

14. An apparatus according to any one of claims 6 to 13, **characterised in that** the at least one wave generated by the wave generator (4) is a pressure wave.

5

## Claims

1. An apparatus for transporting fluid, comprising:

10

a conduit (3);

at least one fluid dividing means (5) in the conduit (3) which divides the conduit (3) into an upstream side and a downstream side, and which fluid dividing means (5) in a first state prevents fluid communication between the upstream side and the downstream side and in a second state allows fluid communication between the upstream side and the downstream side; and an oscillator (8) for moving the fluid dividing means (5),

15

20

### **characterized in that**

the fluid dividing means (5) is arranged in a piston (7') which is connected to the oscillator (8) for being imparted with a translational oscillating motion which causes the fluid dividing means (5) to be alternately brought into the first state and the second state so that an incremental fluid volume flows from the upstream side of the fluid dividing means (5) to the downstream side of the fluid dividing means (5).

25

30

2. An apparatus according to claim 1, wherein the conduit (3) is a pipe.

35

3. An apparatus according to claim 1 or 2, wherein the fluid dividing means (5) is a check valve or a semi-permeable membrane.

4. An apparatus according to any one of the preceding claims, wherein a plurality of fluid dividing means (5) are arranged in the piston (7').

40

45

50

55

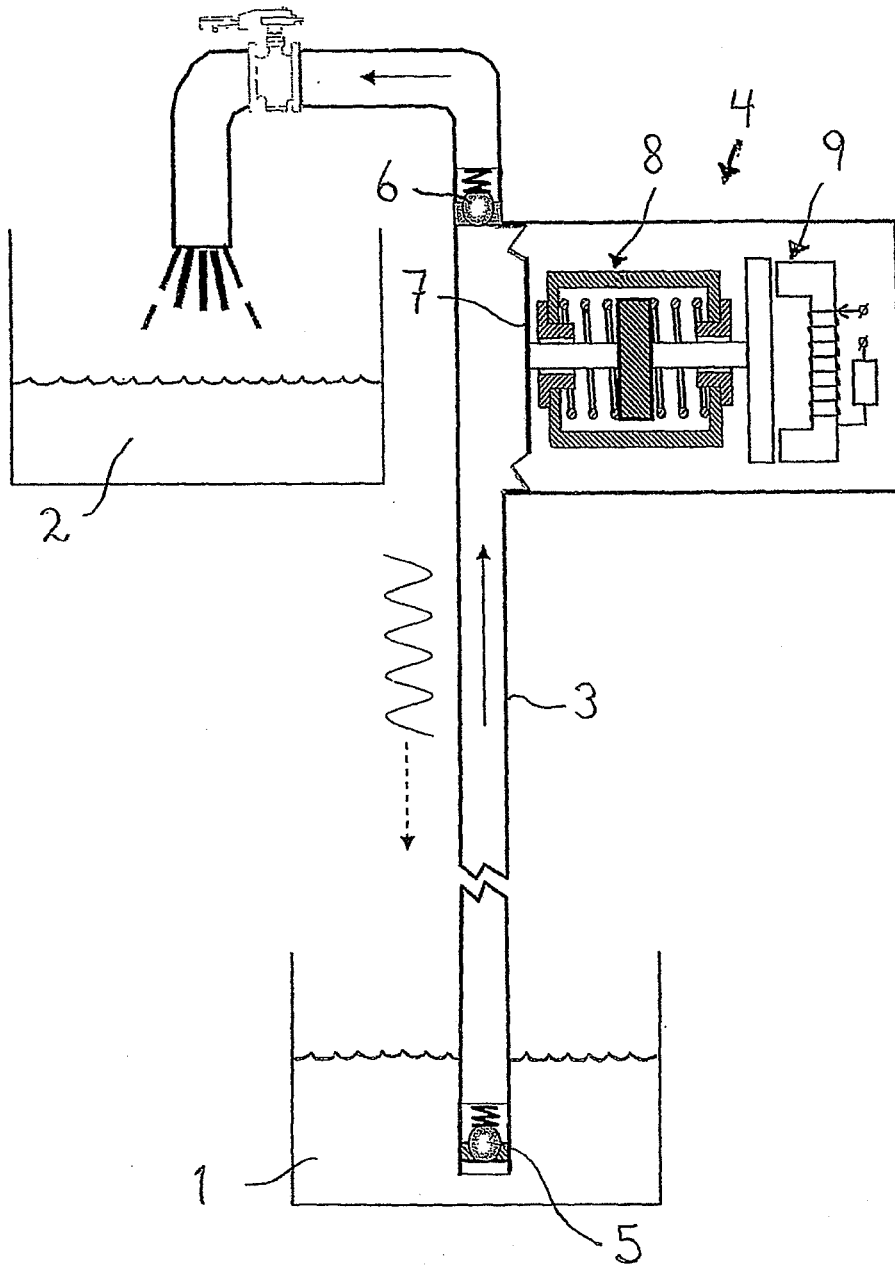

Fig. 1

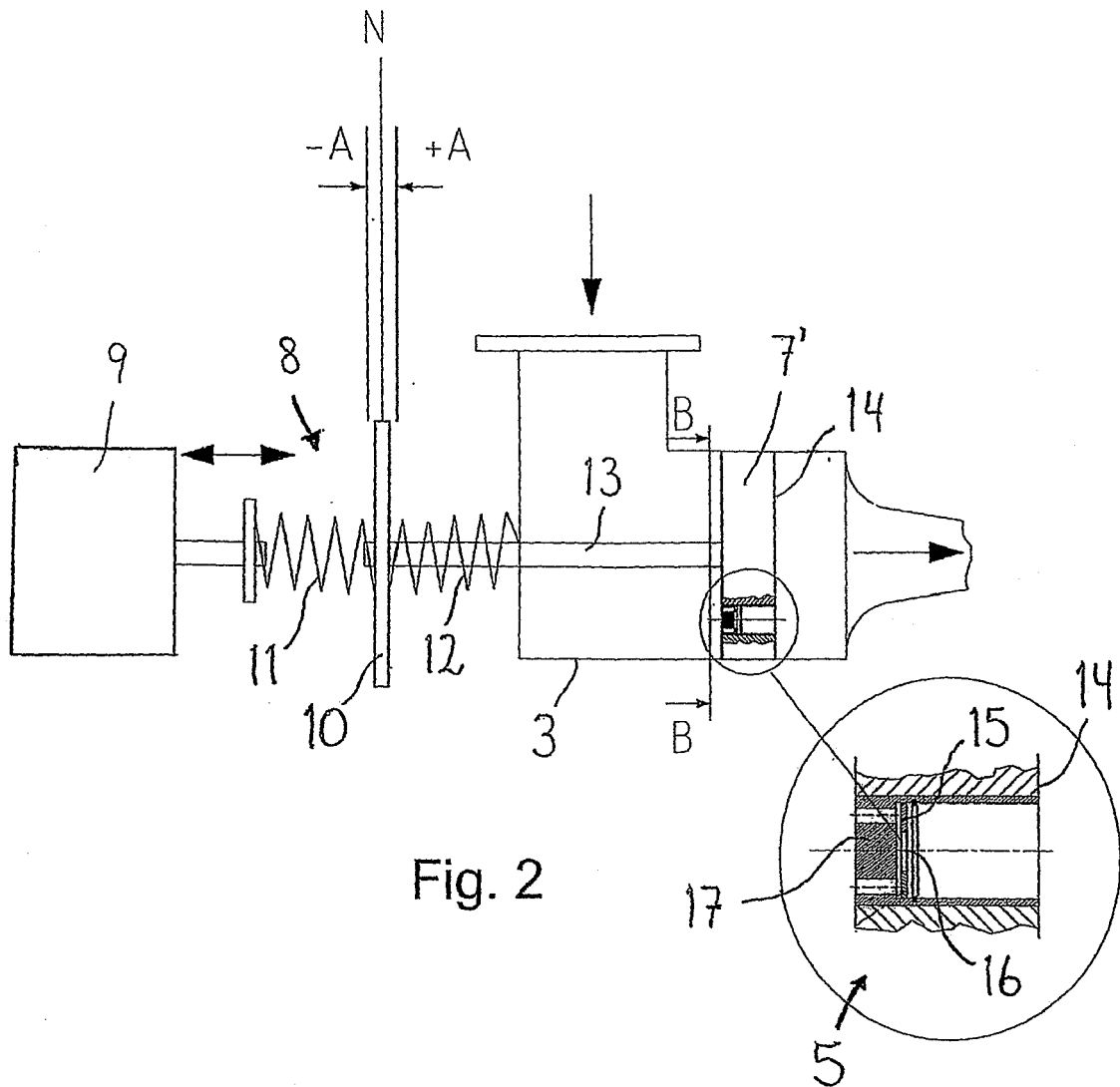

Fig. 2

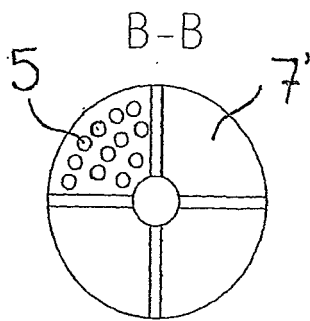

Fig. 3

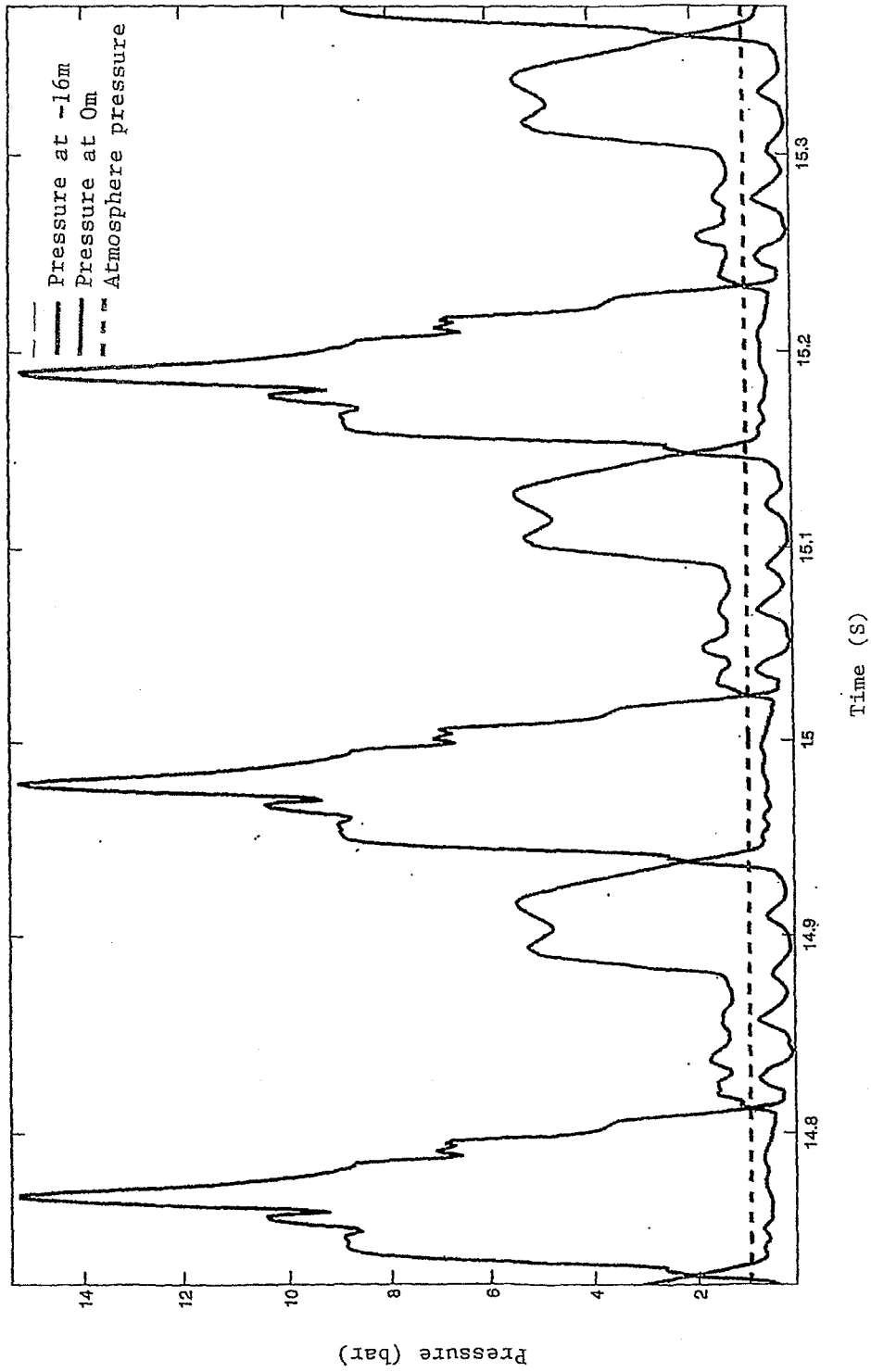

Fig. 5

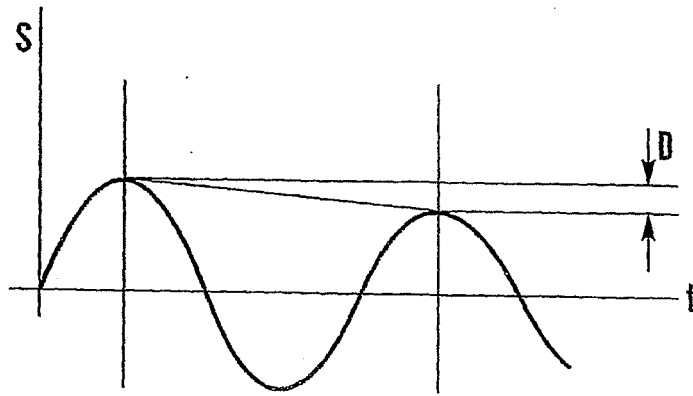

Fig. 4

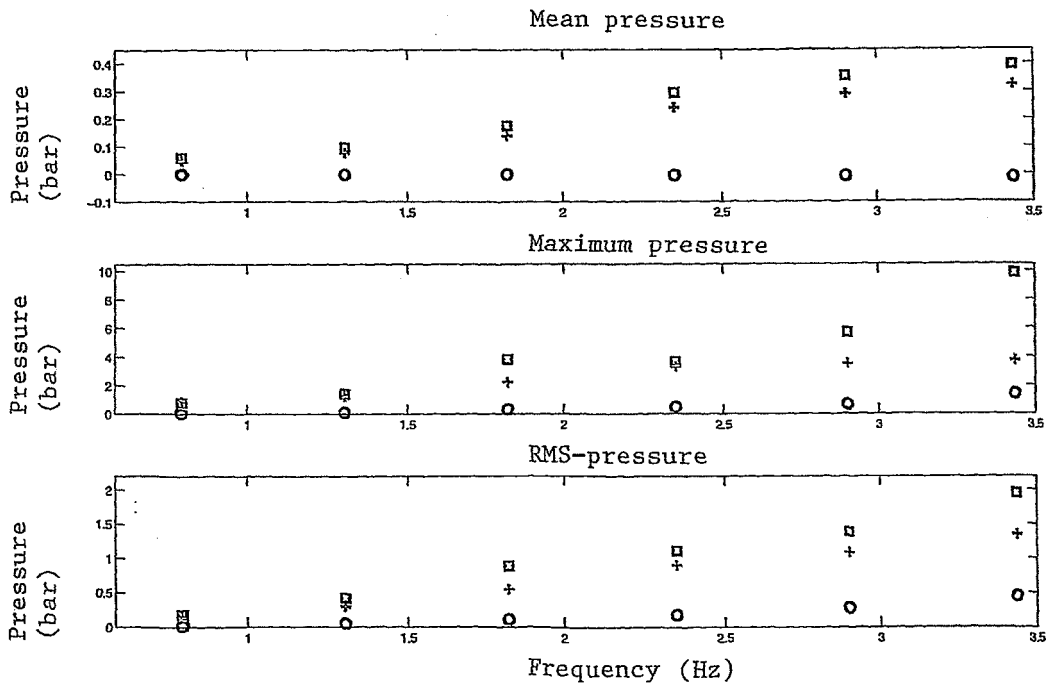

Fig. 6

**REFERENCES CITED IN THE DESCRIPTION**

*This list of references cited by the applicant is for the reader's convenience only. It does not form part of the European patent document. Even though great care has been taken in compiling the references, errors or omissions cannot be excluded and the EPO disclaims all liability in this regard.*

**Patent documents cited in the description**

- EP 05814040 A [0028]
- EP 1859167 A [0028]