

(19) World Intellectual Property Organization
International Bureau



(43) International Publication Date
9 July 2009 (09.07.2009)

PCT

(10) International Publication Number
WO 2009/086482 A1

- (51) International Patent Classification:
A61B 17/22 (2006.01)
 - (21) International Application Number:
PCT/US2008/088371
 - (22) International Filing Date:
26 December 2008 (26.12.2008)
 - (25) Filing Language: English
 - (26) Publication Language: English
 - (30) Priority Data:
61/016,651 26 December 2007 (26.12.2007) US
 - (71) Applicant (for all designated States except US):
LAZARUS EFFECT, INC. [US/US]; 767 El Solyo Heights Drive, Felton, CA 95018 (US).
 - (72) Inventors; and
 - (75) Inventors/Applicants (for US only): **MARTIN, Brian, B.** [US/US]; 767 El Solyo Heights Drive, Felton, CA 95018 (US). **FOLLMER, Brett** [US/US]; 3408 Creighton Place, Santa Clara, CA 95051 (US). **AGUILAR, Julio** [US/US]; 13055 Clayton Road, San Jose, CA 95127 (US). **DIECK, Martin, S.** [US/US]; 235 Cherry Lane, Campbell, CA 95008 (US).
 - (74) Agent: **BAGADE, Sanjay, S.**; Levine Bagade Han LLP, 2400 Geng Road, Suite 120, Palo Alto, CA 94303 (US).
 - (81) Designated States (unless otherwise indicated, for every kind of national protection available): AE, AG, AL, AM, AO, AT, AU, AZ, BA, BB, BG, BH, BR, BW, BY, BZ, CA, CH, CN, CO, CR, CU, CZ, DE, DK, DM, DO, DZ, EC, EE, EG, ES, FI, GB, GD, GE, GH, GM, GT, HN, HR, HU, ID, IL, IN, IS, JP, KE, KG, KM, KN, KP, KR, KZ, LA, LC, LK, LR, LS, LT, LU, LY, MA, MD, ME, MG, MK, MN, MW, MX, MY, MZ, NA, NG, NI, NO, NZ, OM, PG, PH, PL, PT, RO, RS, RU, SC, SD, SE, SG, SK, SL, SM, ST, SV, SY, TJ, TM, TN, TR, TT, TZ, UA, UG, US, UZ, VC, VN, ZA, ZM, ZW.
 - (84) Designated States (unless otherwise indicated, for every kind of regional protection available): ARIPO (BW, GH, GM, KE, LS, MW, MZ, NA, SD, SL, SZ, TZ, UG, ZM, ZW), Eurasian (AM, AZ, BY, KG, KZ, MD, RU, TJ, TM), European (AT, BE, BG, CH, CY, CZ, DE, DK, EE, ES, FI, FR, GB, GR, HR, HU, IE, IS, IT, LT, LU, LV, MC, MT, NL, NO, PL, PT, RO, SE, SI, SK, TR), OAPI (BF, BJ, CF, CG, CI, CM, GA, GN, GQ, GW, ML, MR, NE, SN, TD, TG).
- Published:**
— with international search report

(54) Title: RETRIEVAL SYSTEMS AND METHODS FOR USE THEREOF

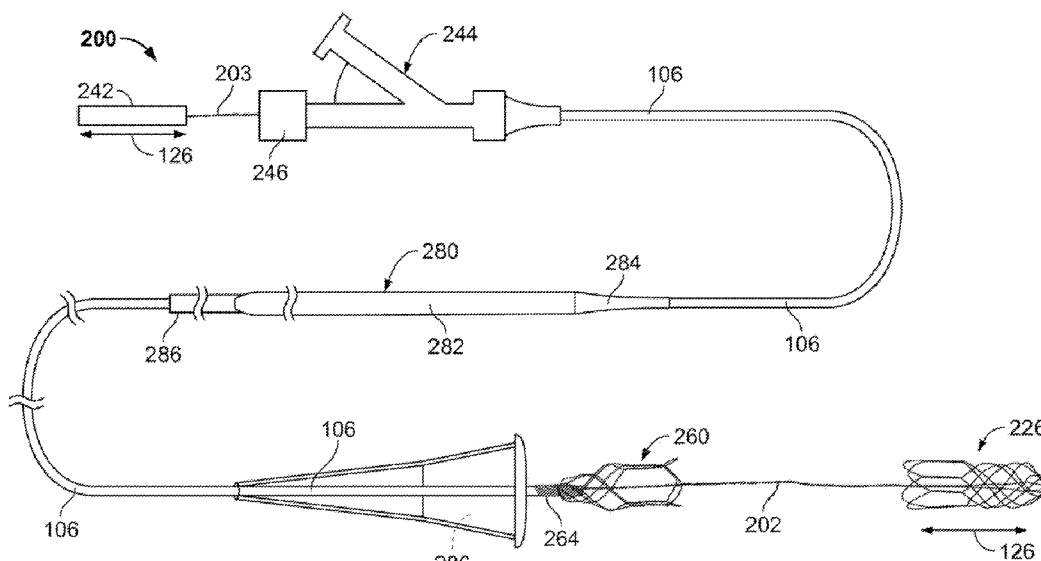

FIG. 10

(57) Abstract: The devices and methods described herein relate to improved structures for removing obstructions from body lumens. Such devices have applicability in through-out the body, including clearing of blockages within the vasculature, by addressing the factional resistance on the obstruction prior to attempting to translate and/or mobilize the obstruction within the body lumen.

WO 2009/086482 A1

RETRIEVAL SYSTEMS AND METHODS FOR USE THEREOF

RELATED APPLICATIONS

[0001] This application is a non-provisional application of U.S. Provisional Application No. 61/016,651 filed on December 26, 2007, the entirety of which is incorporated by reference herein.

FIELD OF THE INVENTION

[0002] The devices described herein are intended to retrieve obstructions from the body. In a first variation, the devices are constructed in wire form where the wires diverge from a main bundle to form a variety of shapes that form a composite device. The benefit of such a diverging wire construction is that the composite complex device can be of a "joint-less" construction. Such devices have applicability through out the body, including clearing of blockages within body lumens, such as the vasculature, by providing a capturing portion that can envelop the obstruction to address the frictional resistance between the obstruction and body lumen prior to attempting to translate and/or mobilize the obstruction within the body lumen. In addition, the devices described below include features that prevent unwanted and premature mobilization of the obstruction when removing the obstruction through tortuous anatomy.

BACKGROUND OF THE INVENTION

[0003] Many medical device applications require advancement of device in a reduced profile to a remote site within the body, where on reaching a target site the device assumes or is deployed into a relatively larger profile. Applications in the cerebral vasculature are one such example of medical procedures where a catheter advances from a remote part of the body (typically a leg) through the vasculature and into the cerebral region of the vasculature to deploy a device. Accordingly, the deployed devices must be capable of achieving a larger profile while being able to fit within a small catheter or microcatheter. In addition, the degree to which a physician is limited in accessing remote regions of the cerebral vasculature is directly related to the limited ability of the device to constrain into a reduced profile for delivery.

[0004] Treatment of ischemic stroke is one such area where a need remains to deliver a device in a reduced profile and deploy the device to ultimately remove a blockage in an artery leading to the brain. Left untreated, the blockage causes a lack of supply of oxygen and nutrients to the brain tissue. The brain relies on its arteries to supply oxygenated blood from the heart and lungs. The blood returning from the brain carries carbon dioxide and cellular waste. Blockages that interfere with this supply eventually cause the brain tissue to stop functioning. If the disruption in supply occurs for a sufficient amount of time, the continued lack of nutrients and oxygen causes irreversible cell death (infarction). Accordingly, immediate medical treatment of an ischemic stroke is critical for the recovery of a patient.

[0005] Naturally, areas outside of ischemic stroke applications can also benefit from improved devices. Such improved devices can assume a profile for ultimate delivery to remote regions of the body and can remove obstructions. There also remains a need for devices and systems that can safely remove the obstruction from the body once they are secured within the device at the target site. Furthermore, there remains a need for such devices that are able to safely removed once deployed distally to the obstructions in the even that the obstructions is unable to be retrieved.

[0006] Accordingly, a need remains for devices that can assume deployed configurations and are fabricated to eliminate or reduce the number of joints and/or connection points in the device.

SUMMARY OF THE INVENTION

[0007] The examples discussed herein show the inventive device in a form that is suitable to retrieve obstructions or clots within the vasculature. The term obstructions may include blood clot, plaque, cholesterol, thrombus, naturally occurring foreign bodies (i.e., a part of the body that is lodged within the lumen), a non-naturally occurring foreign body (i.e., a portion of a medical device or other non-naturally occurring substance lodged within the lumen.) However, the devices are not limited to such applications and can apply to any number of medical applications where elimination or reduction of the number of connection points is desired.

[0008] One variation of the device includes a medical device for removing an obstruction from a blood vessel, the medical device comprises a main bundle comprising a group of wires having a first end and a second end, a capturing portion formed by the group of wires and having a translating surface adjacent to a capturing surface, the translating surface having an open proximal end and the capturing surface having a permeable distal end, where the capturing portion is formed from the group of wires such that the group of wires diverges from the second end of the main bundle to form the permeable distal end, the group of wires extend back in a proximal direction to form the capturing surface, the translating surface, and open proximal end about the main bundle; and where the translating surface and capturing surface are configured so that a translating surface axial strength is greater than a capturing surface axial strength, wherein application of a tensile force on the main bundle causes axial compression of the capturing surface without causing axial compression and deformation of the translating surface sufficient to deform the translating surface as the capturing portion engages the obstruction.

[0009] The medical device can include a capturing surface that is configured to generate a spring force against the translating surface when a proximal force applied by the main bundle of wires compresses the capturing surface against the translating surface when encountering resistance from the obstruction, where the capturing surface is configured to have a sufficient axial stiffness to direct the spring force and proximal force to the open proximal end as the open proximal end engages the obstruction where the capturing surface is also sufficiently flexible to conform to a shape of the vessel.

[0010] In another variation, the capturing section is configured so that when the open proximal end of the translating section engages resistance equal to or greater than a threshold force, proximal movement of the leading wire inverts the capturing section within the translating section and reduces a size of the capturing section to enable the capturing section to re-enter a catheter.

[0011] In those variation of the device that are navigated in tortuous anatomy (such as the cerebral vasculature), the device can include a main bundle joined to a proximal bundle, where the proximal bundle comprises a stiffness greater than the main bundle and where the main bundle extends for at least a predetermined range

from the permeable distal end to allow navigation of a distal portion of the medical device within the cerebral vasculature.

[0012] Another variation of the device includes a retrieval device for removing an obstruction from a body lumen, the system comprising at least one leading wire; a retrieval body comprising a translating section adjacent to a capturing section, the translating section having an open proximal end and the capturing section having a permeable distal end, where the leading wire extends to a portion of the capturing section to permit articulation of the open proximal end relative to the leading wire; and where the translating section and capturing section are configured so that a translating section axial strength is greater than a capturing section axial strength, wherein application of a tensile force on the leading wire causes axial compression of the capturing surface without causing axial deformation of the translating surface when the retrieval body engages the obstruction.

[0013] Variations of the retrieval system can also include a sheath having a hub located at a proximal end, a proximal capture portion affixed to a distal end of the sheath, at least one leading wire extending through the sheath, where a distal section of the leading wire comprises a distal stiffness and where a proximal section of the leading wire comprises a proximal stiffness, where the proximal stiffness is greater than the distal stiffness, a distal capturing portion at the distal end of the leading wire, the distal capturing portion being axially moveable relative to the proximal capture portion, and an insertion tool slidably located over the sheath, the insertion tool comprising a gripping region affixed to a rigid section, where compression of the gripping portion creates a frictional fit between the insertion tool such that when the insertion tool is coupled to the catheter, compression of the gripping portion and axial movement of the insertion tool advances the sheath within the catheter.

[0014] In one variation of the devices described herein, the device comprises a main bundle or group of wires that diverge to form a device having various shapes but few or no connections points or joints (where fabrication of such a construction is referred to as "jointless"). Clearly, the inventive devices described herein are not limited to such a jointless construction. Additional variation includes one or more leading wires that are attached to a capturing portion as described below.

[0015] In another variation, the device includes a main bundle comprising one or a group of wires. The device also includes a capturing portion formed by the wires or wire of the main bundle. The capturing portion includes a cavity or space that is able to surround the obstruction. Accordingly, the capturing portion includes an open proximal end, a permeable distal end, and a capturing surface extending therebetween. The permeable distal end should be sufficiently permeable to allow blood to flow but have sufficient surface area to prevent escape of the obstruction or to prevent particles such as pieces of clot or emboli that would otherwise cause a complication if such pieces migrate through the body. In some variations of the device, the capturing portion is formed from the group of wires such that the group of wires diverges from the second end of the main bundle to form the permeable distal end, the group of wires extend back in a proximal direction to form the capturing surface and open proximal end about the main bundle. Although some closing of the open proximal end can occur, it will not be sufficient to interfere with the obstruction as the capturing portion moves over the obstruction. In some variations, the permeable end may be the distal end or be towards the distal end (meaning anywhere past a proximal end). The terms distal and proximal are relative to the physician (e.g., the distal end is the farthest end from the catheter/physician).

[0016] The devices of the present invention typically include a main bundle from which the wires extend. In most case, the main bundle extends for a length sufficient to withdraw the device from a body of a patient. Accordingly, in such cases, the main bundle shall extend through the length of a catheter. In alternate constructions, the main bundle may be affixed to a single wire or member. In such cases, a main bundle does not extend from the capturing portion to the exterior of the patient. Instead, a single wire extends to the operator interface of the device where the wire is affixed to a main bundle.

[0017] Devices of the present invention can incorporate any number of wires of different characteristics including, but not limited to, materials, shapes, sizes and/or diameters. Clearly, the number of permutations of device configurations is significant. Providing devices with such a composite construction allows for the manipulation of the device's properties to suite the intended application.

[0018] In an additional variation, the surface of the capturing portion can include a wire frame structure, a mesh, a single wound wire, a film, a membrane, a polymer

covering, and a plurality of crossing wires or a heterogeneous mixing of these. In additional variations, a section of the capturing portion can include wires, while another section of the capturing portion can include a film. Clearly, any number of permutations is within the scope of this disclosure. In any case, the capturing surface should prevent the obstruction from escaping as the device is removed from the body. Clearly, the capturing surface can comprise any number of shapes or configurations.

[0019] As noted herein, the joint-less construction improves the flexibility and strength of the device by eliminating joints, connection points, or other attachment points. In addition, the joint-less construction improves the ability of the device to be delivered through a small microcatheter. As a result, the device and microcatheter are able to access remote regions of the vasculature.

[0020] The devices may be fabricated to be self-expanding upon deployment from a catheter. Alternatively, the devices can be constructed from shape-memory alloys such that they automatically deploy upon reaching a pre-determined transition temperature.

[0021] The devices of the present invention may also include features to prevent migration of the obstruction as the capturing portion encapsulates the obstruction. For example, a proximal foot (such as region of increased surface area) can be located on or in the catheter. In another variation, an additional capture portion is located on the catheter where the proximal end of this capture is a mesh, a single wound wire, a film, a membrane, a polymer covering, or a plurality of crossing wires affixed to or in the catheter. Accordingly, the capturing portions both envelope or surround the obstruction as they are moved together. As noted below, additional variations may allow for temporarily locking of the two capturing portions together for increase effectiveness in removing the obstruction from the body.

[0022] The capturing portions disclosed herein can include mechanical features that assist in removal of the obstruction. These features can be hooks, fibers, barb, or any such structure. Any portion of the capturing portion or even the device can have such hooks, fibers, or barbs that grip into the obstruction as the device surrounds the obstruction. It will be important that such features prevent the obstruction from sliding proximally but do not hinder the ability of the practitioner to remove the device from the body.

[0023] The operation of the devices and method described herein secure the obstruction, overcome the friction forces acting on the obstruction, and then remove the obstruction from the anatomy without losing or fractionating the obstruction. In a first variation, the inventive method includes advancing a catheter distal to the obstruction, deploying a first capturing portion distal of the obstruction, where the first capturing portion comprises a translating surface and a capturing surface, the translating surface having an open proximal end and the capturing surface having a permeable distal end, and at least one leading wire affixed to the capturing surface and extending through the capturing portion and through the catheter, where the translating surface and capturing surface are configured so that a translating surface axial strength is greater than that of a capturing surface axial strength, proximally moving the leading wire to compress the capturing surface without compressing the translating surface such that the translating surface gradually advances over the obstruction, and removing the obstruction and first capturing portion from the blood vessel

[0024] Additional variations of the method include (1) passing a catheter distally to the obstruction by passing either through the obstruction and/or between the obstruction and the vascular wall; (2) deploying a first capturing portion distally to the obstruction and the catheter is withdrawn proximal to the obstruction; (3) the capturing portion is then translated over the obstruction by withdrawing the main bundle. Since the main bundle is affixed to a distal end of the capturing portion, misalignment between the bundle and the capturing portion does not cause distortion of the open proximal end. Since the open proximal end remains expanded against the lumen wall, the capturing portion can then be advanced over the obstruction.

[0025] The method and systems may also include the use of an additional capturing portion having an open distal end. This configuration allows the first capturing portion and second capturing portion to envelop or ensnare the obstruction from both the proximal and distal sides. Additional variations even allow for temporarily locking the two capturing portions together. Such a feature increases the ability to remove the obstruction from the body

[0026] It should be noted that reference to surrounding, capturing or securing the obstruction includes partially and/or fully surrounding, engulfing, encapsulating,

and/or securing the obstruction. In any case, a portion of the device engages the obstruction prior to translation of the obstruction within the lumen.

[0027] It should be noted that in some variations of the invention, all or some of the device can be designed to increase their ability to adhere to the obstruction. For example, the wires may be coupled to an energy source (e.g., RF, ultrasonic, or thermal energy) to “weld” to the obstruction. Application of energy to the device can allow the surrounding portion to deform into the obstruction and “embed” within the obstruction. Alternatively, the device can impart a positive charge to the obstruction to partially liquefy the obstruction sufficiently to allow for easier removal. In another variation, a negative charge could be applied to further build thrombus and nest the device for better pulling force. The wires can be made stickier by use of a hydrophilic substance(s), or by chemicals that would generate a chemical bond to the surface of the obstruction. Alternatively, the filaments may reduce the temperature of the obstruction to congeal or adhere to the obstruction.

[0028] Additional variations of the invention include a reentry device for withdrawing an object into a distal end of a sheath, the reentry device comprising an elongate member having a distal portion and a lumen extending therethrough, a plurality of first tines arranged circumferentially at the distal portion, the plurality of first tines each having a distal end forming a first discontinuous funnel where the distal end of each first tine is spaced from the distal end of an adjacent first tine, wherein the first discontinuous funnel is collapsible upon withdrawal into the distal end of the sheath, a second funnel spaced proximal to the first funnel, where the second funnel is collapsible upon withdrawal into the distal end of the sheath, and wherein a distal perimeter of the first discontinuous funnel shape is distal to a distal perimeter of the second funnel.

[0029] In an additional variation, the second funnel comprises a plurality of second tines arranged circumferentially at the distal portion, the plurality of second tines each having a distal end forming a second discontinuous funnel shape where the distal end of each second tine is spaced from the distal end of an adjacent second tine.

[0030] Another example of a reentry device includes an elongate member having a distal portion and a lumen extending therethrough, the elongate member sized to slidably fit within the sheath, a first slotted funnel comprising a plurality of first tines each having free ends discontinuous with free ends of adjacent first tines, where the first

slotted funnel is collapsible upon withdrawal into the distal end of the sheath; and a second funnel located proximal to the free ends of the first tines.

[0031] The reentry device can also comprises a retrieval system for withdrawing an object into a distal end of a sheath. The term sheath, when used with a reentry device, is intended to include any tube, introducer, sheath, or access device. Typically, when the retrieval device is used with neurovascular retrieval devices, the sheath will be a femoral access sheath or device. Regardless, the reentry device includes a first elongate member having a distal portion and a lumen extending therethrough, a second elongate shaft extending through the first elongate member, a flexible layer having a first end inverted on a distal end of the second elongate shaft and a second end affixed to an exterior of the first elongated shaft, where decreasing a distance between the distal end of the second elongate shaft and the exterior of the first elongated member causes the flexible material to form a funnel when the flexible layer further inverts about the second elongate shaft.

[0032] Additional devices and methods for treating ischemic stroke are discussed in commonly assigned U.S. Patent application nos.: 11/671,450 filed February 5, 2007; 11/684,521 filed March 9, 2007; 11/684,535 filed March 9, 2007; 11/684,541 filed March 9, 2007; 11/684,546 filed March 9, 2007; 11/684,982 filed March 12, 2007, 11/736,526 filed April 17, 2007, 11/736,537 filed April 17, 2007, and 11/825,975 filed September 10, 2007; the entirety of each of which is incorporated by reference. The principles of the invention as discussed herein may be applied to the above referenced cases to produce devices useful in treating ischemic stroke. In other words, the wire-shaped construction of devices according to present invention may assume the shapes disclosed in the above-referenced cases when such a combination is not inconsistent with the features described herein.

BRIEF DESCRIPTION OF THE DRAWINGS

[0033] Each of the following figures diagrammatically illustrates aspects of the invention. Variation of the invention from the aspects shown in the figures is contemplated.

[0034] Fig. 1A illustrates an example of a device according to the present invention when used in a system for removing obstructions from body lumens.

- [0035] Fig. 1B illustrates a first example of an obstruction removal medical device.
- [0036] Fig. 1C illustrates the obstruction removal device articulating relative to leading wires (or a main bundle) without deforming an open end of the capturing portion.
- [0037] Figs. 2A to 2E show a capturing portion for use with systems described herein where the capturing portion has sections of varying axial strengths. Such features can optionally be designed to provide a spring force when a section of the capturing portion is compressed and/or staged inversion of the capturing portion so that it can be removed through an immovable obstruction.
- [0038] Fig. 3A illustrates a first variation of the device having a joint-less construction of a capturing portion that articulates about a main bundle of wires.
- [0039] Figs. 3B to 3H illustrate various constructions of capturing portions for use in the present invention.
- [0040] Fig. 4A illustrates a variation of a capturing portion having a main bundle that extends beyond a certain distance to provide a device having an extremely flexible distal region and a relatively stiff proximal region with a strong joint region that will be sufficiently spaced from tortuous anatomy during use of the device.
- [0041] Fig. 4B illustrates a main bundle having a curved or shaped portion.
- [0042] Figs. 4C to 4E illustrate wires of different constructions within a main bundle.
- [0043] Fig. 5A illustrates an example of a proximal foot located on a catheter of the present system.
- [0044] Fig. 5B illustrates a distal and a proximal capturing portion located on a system under the present invention.
- [0045] Figs. 5C to 5E illustrate an overview of a variation of a delivery system employing a proximal and distal capturing portion.
- [0046] Figs. 5F illustrates compression or collapsing of a proximal capturing portion about an obstruction prior to translation of the obstruction in the vessel.
- [0047] Figs. 6A to 6B illustrate an example of traversing an obstruction with a sheath to deploy a distal capturing portion.
- [0048] Figs. 7A to 7C illustrates a condition where a section of the capturing portion deflects to provide a spring force that gradually drives a traversing section along the obstruction.

- [0049] Figs. 7D to 7G illustrate staged inversion of the distal capturing portion to allow removal of the device from an immovable clot.
- [0050] Fig. 8A illustrates closure of the proximal opening of a capturing portion without the benefit of articulation of the capturing portion about a leading wire.
- [0051] Fig. 8B illustrates, conceptually, one benefit of articulation of a capturing portion about a leading wire or main bundle of wires.
- [0052] Figs. 8C to 8D illustrate a proximal capturing portion and a distal capturing portion approaching an obstruction.
- [0053] 8F illustrates a device after securing an obstruction between proximal and distal capturing sections.
- [0054] Fig. 9 illustrates a main bundle as including an increased surface area or medial foot that is used to dislodge or loosen the obstruction from a wall of the body passage.
- [0055] Fig. 10 illustrates a variation of a proximal and distal end of a retrieval device.
- [0056] Figs. 11A to 11C illustrate a variation of a funnel catheter useful for retrieving objects from vessels or body lumens.
- [0057] Fig. 12A shows an example of a retrieval device getting caught on a guide sheath.
- [0058] Figs. 12B to 12C provide illustrative examples of funnel catheter used for removal of an obstruction.
- [0059] Fig. 13A to 13G illustrates another variation of a funnel catheter using a mesh or layer of material to form a funnel.
- [0060] Figs. 14A to 14D illustrate additional concepts to prevent or minimize flaring of the distal capture portion so that it may be withdrawn into a guide sheath.

DETAILED DESCRIPTION

- [0061] It is understood that the examples below discuss uses in the cerebral vasculature (namely the arteries). However, unless specifically noted, variations of the device and method are not limited to use in the cerebral vasculature. Instead, the invention may have applicability in various parts of the body. Moreover, the invention may be used in various procedures where the benefits of the method and/or device are desired.

[0062] Fig. 1A illustrates a system **10** for removing obstructions from body lumens as described herein. In the illustrated example, this variation of the system **10** is suited for removal of an obstruction in the cerebral vasculature. Typically, the system **10** includes a catheter **12** microcatheter, sheath, guide-catheter, or simple tube/sheath configuration for delivery of the obstruction removal device to the target anatomy. The catheter should be sufficient to deliver the device as discussed below. The catheter **12** may optionally include an inflatable balloon **18** for temporarily blocking blood flow or for expanding the vessel to release the obstruction.

[0063] It is noted that any number of catheters or microcatheters may be used to locate the catheter/microcatheter **12** carrying the obstruction removal device **200** at the desired target site. Such techniques are well understood standard interventional catheterization techniques. Furthermore, the catheter **12** may be coupled to auxiliary or support components **14, 16** (e.g., energy controllers, power supplies, actuators for movement of the device(s), vacuum sources, inflation sources, sources for therapeutic substances, pressure monitoring, flow monitoring, various bio-chemical sensors, bio-chemical substance, etc.) Again, such components are within the scope of the system **10** described herein.

[0064] In addition, devices of the present invention may be packaged in kits including the components discussed above along with guiding catheters, various devices that assist in the stabilization or removal of the obstruction (e.g., proximal-assist devices that holds the proximal end of the obstruction in place preventing it from straying during removal or assisting in the removal of the obstruction), balloon-tipped guide catheters, dilators, etc.

[0065] Fig. 1B illustrates a first example of an obstruction removal medical device according to the features described herein. As shown, the device **200** generally includes capturing portion **226** comprising a translating section/surface **222** and a capturing section/surface **224**. In the illustrated variation, the translating section **222** shown comprises a wire framework. However, any number of configurations is within the scope of this disclosure. In many variations of the device, the translating section **222** provides a low friction surface so that it translates over the obstruction without significantly moving the obstruction. This permits the capturing portion **226** to envelop or surround the obstruction prior to attempting to move the obstruction within the body lumen. As noted herein, the translating

section **222** attempts to reduce the outward radial force applied by the obstruction against the wall of the lumen during movement of the obstruction within the lumen.

[0066] Fig. 1B illustrates a distal section of the capturing portion **226** that serves as a capturing section/surface **232**. The capturing section **232** has an increased frictional surface (in this variation illustrated by the crossing **204** wires) so that it can capture and ultimately remove the obstruction. The frictional surface of the capturing section **232** can also be described as an increased coverage density. In essence, as the frictional surface of capturing section **232** coverage density increases, there is a greater “device” surface area to interact with the obstruction. In some variations the capturing section **232** increases in frictional surface between the translating section **234** and the end of the device **200**.

[0067] As shown, the device **200** includes a main bundle **202** comprising a group of individual leading wires **204**. In this variation, the bundle of leading wires **204** is surrounded by a coil or coiled wire **205**. The coiled wire **205** can comprise a single leading wire that joins the device **202**. Alternatively, the coiled wire **205** can extend terminate or wrap back prior to forming the capture portion **226**. Moreover, the coiled wire **205** can extend throughout a length the main bundle **202**, or along one or more segments of the main bundle **202**.

[0068] While the example shows the group consisting of four individual leading wires **204**, the bundle **202** can have any number of leading wires. In various examples 2, 4, or 8 wires were used to construct the device. In certain variations, the number of wires in the main bundle loop around from the capturing portion. For example, if 2 leading wires are used to construct the device, then when constructing the main bundle **202** 2 wires are set to extend distally towards the capturing portion, where the 2 wires are then shaped to form the capturing portion. Eventually, the wires then loop back to extend proximally away from the capturing portion. Therefore, the 2 wires are doubled in the main bundle to create 4 separate wires in the main bundle.

[0069] The individual wires **204** themselves may be comprised of a number of different “micro” filaments, wires, or a single type of wire. Variations of the wires **204** are discussed in detail below; however, the wires **204** can be strands, filaments, or any similar structure that is able to be joined to form the device. The bundle **202** may be braided, wrapped, twisted, or joined in any manner such that

they do not separate or become unbundled except where desired. For example, wires in any section of the device **200** can be bonded together (e.g., with epoxy, a polymeric coating, weld, solder, and/or adhesive, etc.) to prevent the wires from separating during deformation of the device as it deploys or removes the obstruction. In addition, the main bundle **202** can incorporate any number of features to assist in orienting the device **200** within the body passage. For example, the main bundle **202** can include a pre-set bend that would bias the capturing portion **226** in a desired orientation upon deployment as discussed below.

[0070] As also discussed below, variations of the present device **200** include capturing portions **226** where the translating section **234** provides a greater axial strength than an axial strength of the capturing section **232**. The axial strength (e.g., column strength) determines whether the respective section of the capturing portion **226** compresses when the device **200** encounters resistance from an object and as a proximal or pulling force is applied through the main bundle or leading wire **202**. In use, the translating section **234** resists axial compression and deformation so that it can locate about the obstruction. While the nature of moving the translating section will place the structure in a state of compression, there will be no visible deformation or deflection that prevents the translating section from advancing across an obstruction.

[0071] There are a number of approaches to adjust the axial strength of a capturing section **232** as well as the entire structure. In a first example, the manner in which the leading wire is wound to form the respective surface **232**, **234** impact the respective axial strength. As shown, the traversing section **234** comprises a series of wrapped wires extending in an axial direction. This axial alignment causes the wires to oppose axial forces and thus increases the axial strength of the traversing section **234** relative to the capturing section **232**. In the latter section, the wires **232** extend in a helical direction about the section **232**. Thus there is less resistance to an axial load when compared to the traversing section **234**.

[0072] Alternatively, or in combination, additional techniques can produce a device **200** with a capturing portion **226** that has sections of varying axial strength. In one example, the wire diameter can be adjusted to produce the desired column strength. Generally, for a given construction, a larger diameter wire increases the column strength of the section. In addition, larger diameter leading wires can

terminate at the translating section **234** to permit smaller diameter wires to form the capturing section **232**. In another example, the leading wire **204** composition can be selected to produce the desired axial strength. For example, drawn filled tube (DFT) wire has 30% platinum 70% nitinol. Decreasing the amount of platinum and increasing the nitinol increases the wire strength and results in higher column strength. In yet another example, the respective section, or the entire capturing portion **226**, can be processed to produce the desired axial strength. For example, changing the annealing profile (e.g., temp, time) affects the wire strength, and therefore the axial strength.

[0073] Variations of devices **200** described herein can have capturing portions with alternate configurations than those shown in above. The capturing portion **226** can include constructional designs such as a basket, a filter, a bag, a coil, a helical wire structure, a mesh, a single wound wire, a film, a membrane, a polymer covering, , or a plurality of crossing wires. In variations of the device, the capturing portion **226** is sufficiently permeable to allow blood or other fluid flow therethrough. As noted above, capturing portion **226** may be any structure that covers, encapsulates, engulfs, and/or ensnares the obstruction either fully or partially. Accordingly, although the capturing portion **226** is illustrated as a filter/bag, the wires may diverge to form a coil, helical shape, other mesh structure, or any other structure that defines a space that can be translated over the obstruction to ultimately remove the obstruction **2**.

[0074] The capturing portion **226** can include an open proximal end **228**, a permeable distal end **230** and a capturing surface **232** located therebetween. The capturing surface **232** of the capturing portion **226** defines a volume, cavity, or space that is able to cover, encapsulate, envelop, engulf, ensnare and/or surround the obstruction. Generally, the term traversing wire or filament refers to the section of leading wire **204** that forms the traversing surface **238**. Generally, the traversing wires form the capturing surface **238** and then form the open proximal end **228**. As discussed herein and illustrated below, the open proximal end **228** expands within the lumen, typically to the lumen walls, so that the obstruction enters the open proximal end **228** as the bundle **202** (or leading wire) translates the device **200** proximally.

[0075] The permeable distal end **230** is typically sufficiently porous so that fluid or blood may flow through. However, the end **230** is sufficiently closed (or has an

increased surface area) so that the obstruction should not escape through the distal end **230** of the device **200**. This construction typically causes the the obstruction to become ensnared within the capturing portion **226** and prevented from passing through by the permeable distal end **230**.

[0076] As shown in Fig. 1C, an important feature of the present devices **200** is that the main bundle **202** and capturing portion **226** can articulate relative to one another without interfering with the size or profile of the open proximal end **228**. This feature is described more fully below. As shown, the main bundle **202** extends through the open proximal end **228** and through at least a the traversing section **234** capturing portion **226**.

[0077] Fig. 1C illustrates a condition where the main bundle **202** and capturing portion **226** articulate relative to one-another. Because the main bundle **202** joins the capturing section **232** at a distance from the open proximal end **228** movement of the main bundle **202** relative to an axis **236** of the capturing portion **226** does not reduce a profile of the open proximal end **228**. If the main bundle **202** were affixed or connected to the open proximal end **228**, then any movement of the bundle **202** away from the capturing portion's axis **236** would exert a force on the open end. This force, in turn, would cause the open end to narrow or deform. By doing so, the open end would not be able to uniformly expand against the lumen wall to capture the obstruction.

[0078] Turning now to the construction of the device **200**, as shown above, the main bundle or a leading wire **202** extends beyond the open proximal end **228** and forms the capturing portion. In one variation, the construction of the device relies on converging/diverging wires to form continuous shapes so that the device is completely joint or connection free. However, as noted herein, the leading wire or main bundle **202** can be affixed to a structure that forms the capturing portion via an attachment point, joint, or junction. In addition, the structures forming the capturing portion can be fabricated from such processes as laser cutting of tubes, etching, metal injection molding, or any other such process.

[0079] The devices of the present invention can also include additional features to aid in removal of obstructions. For example, as shown in Figs. 1B to 1C, the open proximal end **228** can include one or more petals or flanges **238** extending radially outward. The flanges **238** allow device **200** to have a flared structure at the open proximal end **228**. In one example, the capturing portion **226** can be slightly

oversized relative to the body passage containing the obstruction or slightly larger than the capturing portion. The flanges **238** provide an additional force against the wall of the passage to ensure that the device **200** is able to surround or encapsulate the obstruction. In yet another feature, in variations of a system having a proximal and distal capturing portion, the flanges can serve to lock the proximal and distal capturing portions together once they encapsulate or surround an obstruction. This feature minimizes the chance that the obstruction escapes from the capturing portions as the device and obstruction are removed from the body lumen.

[0080] In additional variations, the main bundle can diverge to form the capturing portion in multiple locations so long as the capturing portion's ability to articulate is not sacrificed. For example, the main bundle can diverge in several locations along the capturing surface (not shown).

[0081] Figs. 1B to 1C also shows an integrally formed reinforcement ring **240** located along the length of the capturing surface **232** (i.e., on the traversing wires). The reinforcement ring **240** can be a separate or discrete ring located on or in the capturing surface **232**. Alternatively, or in combination, the reinforcement ring **240** can be a ring shape that is integrally formed through arrangement of the wires **204** (as show in Figs. 1B to 1C). The reinforcement ring **240** assists in expanding the device when deployed in the body lumen and/or prevents the device (e.g., the open proximal end) from collapsing as the device moves within the lumen to secure the obstruction. The reinforcement ring **240** can comprise a single wire, or a twisted pair of wires. Alternatively, the rings do not need to extend entirely circumferentially around the capturing surface. Instead, a reinforcement portion may extend between adjacent traversing wires but does not necessarily extend around the circumference of the capturing section. As noted herein, reinforcement portions may extend between adjacent traversing wires in multiple locations.

[0082] Figs. 2A to 2E show several benefits of varying axial strengths of the different sections of a capture portion **226**. As shown in Fig. 2A, when the physician retrieves the capturing portion **226** by pulling on the leading wire or main bundle **202** (as shown by arrow **120**), the entire capturing portion **226** translates as shown by arrow **122**. However, when the device **200** encounters resistance (as schematically shown by force arrows **124**) the lesser axial strength of the capturing section **232** causes axial deformation or compression of the capturing section **232** (as shown by Fig. 2B). In certain variations, the capturing section **232**

can be constructed to function as spring such that deformation of the capturing section **232** stores energy. Accordingly, the physician can pull the main bundle **202** to build energy in the capturing section **232**, then relax the force on the main bundle **202**. The stored energy in the capturing section **232** gradually drives the open proximal end of the translating section **234** over or along the obstruction. The physician can apply this “pull and relax” technique repeatedly until the obstruction is sufficiently captured by the capturing portion **226**.

[0083] Fig. 2C shows an additional safety benefit given the varying axial strengths of the different sections of a capture portion **226**. In the event the capturing portion **226** encounters an excessive degree or threshold of force (as denoted by arrows **124**), the reduced axial strength of the capturing section **232** can invert within the translating section **234**. As shown, the permeable distal end **230** of the capturing section **232** inverts and is pulled by the main bundle **202** within the translating section **234** and reduces in size. As shown in Fig. 2D, continued pulling on the main bundle **202** causes eventual inversion of the translating section **234** so that the capturing section **232** extends through the translating section **234** and the permeable distal end **230** is now proximal to the translating section **234**. Continuing to apply move the main bundle **202** in a proximal direction **120** inverts the capturing portion **226** as shown in Fig. 2E. As shown, the translating section **234** is now distal to the capturing section **232**. This causes a reduction in the size of the capturing portion through inversion of the capturing portion **226**. This feature permits withdrawal of the capturing portion **226** within a delivery sheath **106** or through an immobile obstruction (as discussed below). As shown below, the ability to sequentially invert the capturing portion **226** and reduce its diameter enables retrieval of the device if deployed distal to atherosclerotic plaque or an immobile object where continued pulling against the object could cause damage or tearing of the body passage or vessel wall. It was found that retrieval devices that are not constructed with regions of varying axial strength, spring function, or staged inversion can often flatten or expand in diameter when attempting to retrieve the device through an immobile or stubborn obstruction.

[0084] Fig. 3A illustrates an additional variation of a capturing portions **226** according to the present disclosure. In Fig. 3A, the main bundle **202** and the group of wires **204** branch or diverge at the permeable distal end **230** to form the capturing portion **226**. In additional variations, the main bundle **202** can branch or

diverge within a mid-portion of the capturing surface **232** rather than at the permeable distal end **230**. In such a case, the wires **204** form the capturing surface **232** first and ultimately branch to form the remainder of the capturing portion. In any case, by extending through the open proximal end **228**, the main bundle **202** is able to articulate relative to the capturing portion **226** without significantly reducing a profile of the open distal end **228**. As discussed above, the capturing surface **232** of these variations is fabricated (either through processing or wire construction) to have an axial strength that is lower than that of the traversing section **234**.

[0085] Fig. 3B illustrates a variation having an integrated reinforcement ring **240**. Typically, the reinforcement ring **240** provides radial strength to the capturing portion **226** to prevent collapse or deformation that would otherwise interfere with enveloping the obstruction. A reinforcement ring **240** may allow for use of wires that would otherwise provide unacceptable radial strength. For example, the reinforcement ring **240** may permit use of smaller diameter wires thereby allowing the device **200** to compress to a smaller diameter during delivery via a catheter.

[0086] In addition to the reinforcement ring **240**, Fig. 3B includes an open proximal end **228** having a number of petals/flanges **238**. In this variation, although the flanges **238** intersect one another, they are independently moveable.

[0087] Fig. 3C shows a variation of a device **200** where the capturing portion **226** includes flanges **238** that are interwoven or connected with adjacent flanges **238**. (Variations include bonding or otherwise joining the adjacent flanges together.) This feature provides the flanges **238** with a higher radial strength that reduces the likelihood that the flanges **238** bend or distort when moving in the body lumen or removing the obstruction.

[0088] Figs. 3D to 3E illustrate additional variations of devices having capturing portions **226** that have a basket type configuration. As shown, the capturing portions **226** and surface **232** comprise a denser mesh of traversing wires that ultimately lead to the traversing section **234** that terminates in flanges **238** at the open proximal end **228**. In such variations, a first portion of the traversing surface **232** that is adjacent to the open proximal end has a low coverage density relative to the remaining portion of the capturing surface having a higher coverage density that eventually forms the permeable distal end **230**. This construction lowers the lowering frictional resistance of the first portion of the capturing surface when

moving over or against the obstruction but allows the remaining portion of the capturing surface to encapsulate and secure the obstruction.

[0089] As shown in Fig. 3E, the wires diverge from the main bundle towards the distal end of the capturing portion **226** to form the permeable distal end **230**. The permeable distal end **230** can actually have the same configuration as the capturing surface **232**. In other words, the permeable distal end can simply be an extension of the capturing surface that extends over the distal end of the capturing portion.

[0090] Naturally, the divergence of the wires can occur over a length of the capturing portion **226** rather than immediately at the distal end. For example, as show in Fig. 3D, the wires diverge towards a mid-section of the capturing portion and ultimately form the permeable distal end **230**.

[0091] Fig. 3F illustrates a variation of a device **200** having multiple reinforcement rings **240**. As noted above, the reinforcement rings provide additional radial strength to the capturing portion **226** as the device **200** moves within the body lumen and prevents distortion of the capturing portion **226**. However, as noted above, the device will be fabricated to provide varying regions of axial strength to allow for either the spring effect or the staged inversion discussed above. In any case, the rings **240** do not need to extend around an entire circumference of a device, variations include any number of supports that extend between adjacent traversing wires.

[0092] Fig. 3G illustrates another variation of a device **200** having a leading wire **202** extending to a distal end **230** of a capturing portion **226**. In this variation the capturing portion **226** is fabricated from a stent-type structure. As noted above, it is within the scope of this disclosure to use any type of similar structure such as a laser cut tube, a chemically etched or photo etched tube, a polymer or metal injection molded structure, a basket, a filter, a bag, a coil, a helical wire structure, a mesh, a single wound wire, a film, a membrane, a polymer covering, or a plurality of crossing wires as the capturing portion **226** so long as the device can be compressed to a small size for delivery and expand after traversing the obstruction. The illustrated variation also shows a covering **270** located on the distal end **230** of the capturing portion **226**. The length of the polymeric covering **270** can vary across the capturing portion **226** to prevent the obstruction from escaping as the device is translated over the obstruction. Furthermore, the covering **270** can be polymeric or a wire mesh. However, typically the covering has sufficient porosity

to allow blood to flow through the device **200**. In this variation, the flanges **238** form the translating surface.

[0093] Fig. 3H illustrates another feature for use with system described herein. In this variation, the system includes a proximal capturing portion **260** located on an exterior of a delivery sheath **106**. The main bundle **202** extends through the sheath **106** to a distal capturing portion (not shown). As discussed below, the proximal capturing portion **260** can be similar to the distal capturing portions **226** described herein with the exception that the distal end **262** of the proximal capturing portion is open while the proximal end **264** of the proximal capturing portion is closed. Furthermore, the proximal capturing portion **260** articulates with respect to the sheath **106** much in the same manner as the distal capturing portion **226** articulates relative to the main bundle **202**. In this variation, the proximal end **264** of the proximal capturing portion **260** is tapered or has a smaller profile than the remaining proximal capturing portion **260**. Such a feature may be useful to improve the deliverability of the device to the intended site as well as to maneuver around any obstructions within the body passage. In addition, as noted below, the proximal capturing portion **260** can be compressed about the obstruction to improve the ability of the system to remove the obstruction. The construction of the proximal capturing portion **260** can optionally include variations having regions of differing axial strength, or sections capable of generating spring force. Typically, since the proximal capturing portion **260** is not advanced distal to the obstruction, the need for staged inversion is not necessary. Accordingly, any number of capturing designs can be incorporated for the proximal capturing portion.

[0094] In some variations, the leading wire can extend to the proximal end of the system for manipulation by the physician. However, it is often the case that the characteristics of the device must vary along its length. For example, when the device is intended for use in remote tortuous anatomy, the proximal section of the device is desirably stiffer (to advance the distal portion of the device to the target anatomy). However, the distal section of the device must have properties that make it suitable for the tortuous anatomy. In the case where devices are used in the cerebral vasculature, the distal section must be extremely flexible, while the proximal section should be stiff. In many cases, different material properties are

required. A problem then arises in attempting to join different materials especially in the joining region.

[0095] Conventional joining methods include soldering, welding, gluing, thermal junctions, etc. These joining methods produce an area having an increase in the stiffness of the device. For example, if two wires are to be laser welded together, then the section where they are joined has an overlap which yields greater stiffness than the rest of the wire. This increased area of stiffness is often balanced against the strength of the joined segment. If the joined region is too long, the strength will be sufficient but the increase in stiffness often prevents navigation through the tortuous anatomy. If the joined region is too short, then the device can navigate through the anatomy but the bond is weaker and a risk of failure increases.

[0096] Fig. 4A illustrates another variation of an improvement for use with the devices described herein especially for use in tortuous anatomy such as the cerebral vasculature. In this example, the capturing portion **226** is shown with a number of leading wires **204** extending proximally. To provide the desired characteristics, the leading wires **204** are joined in region **196** to wires **198** having a structure that is suitable for the proximal anatomy (e.g., the wires are larger in diameter or stiffer). To enable use of the device **200** in the cerebral anatomy without compromising bond strength characteristics or flexibility of the device **200**, the leading wires extend a pre-determined region so that the bond region **196** is placed out of the tortuous anatomy. Since the cerebral vasculature is approximately 30 centimeters in length, the leading wires **204** can extend for a length **195** of at least a predetermined length so that it remains very flexible when navigating the cerebral vasculature or other tortuous anatomy. In one example the length was 20 centimeters (but can be 30 or more centimeters). By deliberately extending the leading wires **204** by length **194**, the length of the bond region **196** can be chosen to accommodate the proximal anatomy (where a greater stiffness of the bond region **196** can be accommodated). The length of the bond region **196** can vary depending on the application (e.g., from 2 to 20 cm for a device intended for cerebral the cerebral vasculature). However, the bond can extend along the entire proximal section of leading wire.

[0097] Fig. 4B illustrates an additional aspect of for use with devices described herein where the main bundle **202** has a curved or bend portion **252**. This pre-set

shape assists in orienting the capturing portion **226** within the body passage since the bend will cause the device to bias against a wall of the body passage.

[0098] Fig. 4C and 4D show cross sectional views taken along the line A-A in Fig. 4B. As shown, the wire form construction described herein allows for a number of configurations depending on the particular application. For example, the individual wires **204** (as discussed herein) may themselves comprise a bundle of smaller wires or filaments. In addition, the wires can be selected from materials such as stainless steel, titanium, platinum, gold, iridium, tantalum, Nitinol, alloys, and/or polymeric strands. In addition, the wires used in a device may comprise a heterogeneous structure by using combinations of wires of different materials to produce a device having the particular desired properties. For example, one or more wires in the device may comprise a shape memory or superelastic alloy to impart predetermined shapes or resiliency to the device. In some variations, the mechanical properties of select wires can be altered. In such a case, the select wires can be treated to alter properties including: brittleness, ductility, elasticity, hardness, malleability, plasticity, strength, and toughness.

[0099] The device may include a number of radiopaque wires, such as gold and platinum for improved visibility under fluoroscopic imaging. In other words, any combination of materials may be incorporated into the device. In addition to the materials, the size of the wires may vary as needed. For example, the diameters of the wires may be the same or may vary as needed.

[0100] In addition, the individual wires may have cross-sectional shapes ranging from circular, oval, d-shaped, rectangular shape, etc. Fig. 4C illustrates one possible variation in which a number of circular wires **204** are included with a d-shaped wire **205**. Moreover, the device is not limited to having wires having the same cross-sectional shape or size. Instead, the device can have wires having different cross-sectional shapes. For example, as shown in Fig. 4D, one or more wires **205** can have a different cross-sectional shape or size than a remainder of the wires **204**. Clearly, any number of variations is within the scope of this disclosure.

[0101] To illustrate one such example, a device can have 8-12 wires made of .003" round superelastic material (e.g., nitinol). The device may additionally have 2-4 wires made from .002" platinum for fluoroscopy. Of the 8-12 nitinol wires, 1-4 of these wires can be made of a larger diameter or different cross-section to increase the overall strength of the device. Finally, a couple of polymer fibers can

be added where the fibers have a desired surface property for clot adherence, etc. Such a combination of wires provides a composite device with properties not conventionally possible in view of other formation means (such as laser cutting or etching the shape from a tube or joining materials with welds, etc.). Clearly, any number of permutations is possible given the principles of the invention.

[0102] In another example, the device may be fabricated from wires formed from a polymeric material or composite blend of polymeric materials. The polymeric composite can be selected such that it is very floppy until it is exposed to either the body fluids and or some other delivered activator that causes the polymer to further polymerize or stiffen for strength. Various coatings could protect the polymer from further polymerizing before the device is properly placed. The coatings could provide a specific duration for placement (e.g., 5 minutes) after which the covering degrades or is activated with an agent (that doesn't affect the surrounding tissues) allowing the device to increase in stiffness so that it doesn't stretch as the thrombus is pulled out. For example, shape memory polymers would allow the device to increase in stiffness.

[0103] In another variation, one or more of the wires used in the device may comprise a Drawn Filled Tube (DFT) such as those provided by Fort Wayne Metals, Fort Wayne, Indiana. As shown in Fig. 4E, such a DFT wire 252 comprises a first material or shell 208 over a second material 210 having properties different from the outer shell. While a variety of materials can be used, one variation under the present devices includes a DFT wire having a superelastic (e.g., Nitinol) outer tube with a radiopaque material within the super-elastic outer shell. For example, the radiopaque material can include any commercially used radiopaque material, including but not limited to platinum, iridium, gold, tantalum, or similar alloy. One benefit of making a capturing portion from the DFT wire noted above, is that rather than having one or more markers over the capturing portion, the entire capturing portion can be fabricated from a super-elastic material while, at the same time, the super-elastic capturing portion is made radiopaque given the core of radiopaque material within the super-elastic shell. Clearly, any composite DFT wire 252 can be incorporated into the system and capturing portions described herein.

[0104] Fig. 5A shows a working end of a variation of a system **10** for removing an obstruction from a body lumen. In this variation, the system **10** includes a main

bundle **202** and capturing portion **226** extending out of a micro-catheter or catheter **102**. The micro-catheter **102** can optionally include a proximal foot **256** that can slide axially over main bundle **202** and can be variably positioned in relation to the capturing portion **226**. The proximal foot **256** can include any number of configurations apart from the petal/flange **258** configuration (i.e., the foot can be a balloon, coil, shoulder, etc. where such structures simply replace the petals in Fig. 5A). In any case, the proximal foot **256** provides an increased surface area that provides an opposing force to the capturing portion **226**, where the opposing force aids the movement of the obstruction within the capturing portion **226**. Alternatively, the proximal foot stabilizes the obstruction and keeps the obstruction from moving with the capturing portion until the capturing portion envelops the obstruction.

[0105] The size of the proximal foot **256** can be adjusted depending on the target site anatomy. For example, a larger surface area can be employed if the target site is within a bifurcation of the body passage. The size of the proximal foot **256** can also be adjustable during the procedure. For example, in the case of a petal/flange **258** configuration, the petals **258** can assume a larger size to initially stabilize the obstruction and then reduce in size to allow the obstruction to be completely engulfed by capturing section **226**.

[0106] The proximal foot **256** can extend from an interior of the catheter **102**, such as from within the internal lumen of the catheter, or from an additional lumen within a wall of the catheter. Alternatively, the proximal foot **256** can be permanently affixed to the catheter **102**. In such a case, a separate catheter (without a proximal foot) can be employed to traverse the obstruction for deployment of the device distally to the obstruction. Once the device is deployed, the catheters can be exchanged to provide the proximal foot. In an additional variation, the proximal foot **256** can be affixed to a delivery sheath (as described below) and be collapsed within the catheter, where advancement out of the catheter expands the proximal foot **256** so that it may function as described above.

[0107] In an additional variation, a proximal capturing portion (as shown in Fig. 3H) can be used with a foot **256** that is located about the main bundle **202**. Such a variation may or may not include a distal capturing portion. Accordingly, the construction of the proximal capturing portion (as described herein to include

sections of varying axial strength) can be used to perform a push and relax technique (similar to that of the pull and relax technique described herein).

[0108] Fig. 5B illustrates another variation of the system **10** where the system includes a proximal capturing portion **260** located on an exterior of a delivery sheath **106**. Naturally, the proximal capturing portion **260** could also be affixed to an exterior of a micro-catheter. The proximal capturing portion **260** is similar to the capturing portions **226** described herein with the exception that the distal end **262** of the proximal capturing portion is open while the proximal end **264** of the proximal capturing portion is closed. The proximal capturing portion can also optionally be configured to have regions of varying axial strength, spring rate, and various other features associated with the distal capturing portion **226**. In the illustrated variation, the capturing portion **226** and main bundle **202** move relative to the proximal capturing portion **260** to capture an obstruction. Furthermore, the proximal capturing portion **260** articulates with respect to the sheath **106** much in the same manner as the distal capturing portion **226** articulates relative to the main bundle **202**. As shown, the petals **238** on the open ends **228** and **262** can interact to nest once the capturing portions **226** and **260** are moved sufficiently close to one another. The outward force caused by the retained obstruction provides a frictional interaction between adjacent petals/flanges **238** to maintain the nesting.

[0109] Variations of the device include additional structures, such as springs, hooks, barbs, etc, to cause the open ends **228** and **262** to interlock. As noted above, a separate catheter can be used to initially deploy the capturing portion **226** beyond the obstruction. Although the capturing portions shown have the same configuration, the capturing portions **226** and **260** used in any given system do not have to match in size, shape, and configuration. For example, the proximal capturing portion can be impermeable to flow while the distal capturing portion allows flow. In another example, one basket may be undersized relative to the other to improve nesting.

[0110] In any case, the construction of the system **10** shown in Fig. 5B includes open ends **228** and **262** of capturing portions **226** and **260** that are unconnected. Accordingly, as the capturing portions **226** and **260** move towards one another as a result of the main bundle **202** translating relative to the delivery sheath **106** the open ends are free to articulate around the main bundle **202** and delivery sheath **106** respectively to remain expanded against the lumen wall.

[0111] Figs. 5C to 5E illustrate a variation of a system for delivery of the capturing portions 226 and 260. Fig. 5C shows the proximal 260 capturing portion affixed to a delivery sheath 106. In alternate variations, the proximal capturing portion 260 can be replaced with a proximal foot (not shown). As noted above, the main bundle or leading wires 202 extends through the delivery sheath 106 and connects to the distal capturing portion 226 beyond the opening 228 of the distal capturing portion 200. The main bundle or leading wire 202 extends through the proximal capturing portion 260. This allows the free ends of the capturing portions 228 and 262 to remain relatively unattached so that they can articulate and conform to the curvature of the vessels (as discussed below). The capturing portions 226 and 260, main bundle 202 and delivery sheath 106 extend through a microcatheter 102.

[0112] Fig. 5D illustrates a state of deployment after the microcatheter 102 traverses the obstruction (not shown). Once the microcatheter 102 is distal to the obstruction, the distal capturing portion 226 deploys from the end of the microcatheter 102. As noted herein, the capturing portions can self-expand or can expand upon actuation by the physician. In any case, the distal capturing portion 226 should be sufficiently collapsible to remain within the microcatheter 102 for deployment distal to an obstruction. To deploy the distal capturing portion 200 from the catheter 102, the main bundle 202 can translate to push the distal capturing portion 226 to eject it from the catheter 102. Alternatively, the microcatheter 102 can be withdrawn from the distal capturing portion 226.

[0113] Fig. 5E illustrates the deployment state after the catheter 102 is withdrawn proximal to the obstruction (not shown) and after the proximal capture portion 260 is delivered from the microcatheter 102. As noted above, the proximal capture portion 260 can be affixed to an exterior of the catheter, in which case the catheter may be either de-sheathed or exchanged. Alternatively, and as shown, the proximal capturing portion 260 is affixed to a delivery sheath 106 and is fabricated to collapse within the microcatheter for ultimate deployment, whereby translating the sheath 106 delivers the proximal portion 260 from the microcatheter.

[0114] Fig. 5F shows another aspect of the system 10 where the proximal end 264 of the proximal capturing portion 260 is collapsed or compressed about an obstruction 2 prior to translation of the obstruction 2 within the vessel. In this illustration, the proximal capturing portion 260 is compressible by advancing the catheter 102 over the closed proximal end 264 of the capturing portion 260. In

such a case, the proximal capturing portion **260** is slidable within and relative to the catheter **102**. Naturally, variations may include compressing the proximal end **264** during translation of the obstruction **2**. In either case, the proximal capturing portion **260** can be compressed in a number of different ways. For instance, the proximal basket can be compressed using a catheter **102**(as shown), or the delivery sheath **106**, or any other number of mechanisms (not illustrated).

[0115] As shown, the proximal end **264** can be compressed using a sheath **106** and/or catheter **102**. However, other means of compressing may be employed (e.g., a loop structure, a tube over the sheath, a draw-string configuration, etc.) In use, once the distal capturing portion **226** is deployed distally to the obstruction **2** and the catheter **102** is withdrawn proximal to the obstruction **2**, the proximal capturing portion **260** is deployed. As the proximal capturing portion **260** partially (or totally) engulfs the obstruction **2**, the physician can collapse or compress the proximal capturing portion **260** to better secure the obstruction within the system **10**.

[0116] It is noted that any number of shapes, configurations, as well as any number of joined wires may be contemplated to form devices under the present disclosure. However, variations of the invention include selecting a number of wires to produce specific structural properties to the device. For example, the devices can have any number of wires where the limit is determined by the ability to produce a device of a sufficiently small size to access the area containing the obstruction. However, in some cases, it may be desired that wires are chosen to impart specified characteristics. For example, in the illustrated variation, the main bundle may comprise any number of wires that do not diverge to form subsequent shapes in the device. In other words, not all of the wires forming a section are required to diverge to form an adjacent section. Instead, these non-diverging wires may simply "loop" back away from the device. In an additional variation, one or more wires may diverge to form a particular portion of the capturing portion (e.g., the closed end, traversing wires, etc.). Then the wires can loop back to converge again with the main bundle.

[0117] Figs. 6A to 6E show one example of the deployment of a variation of a device according to the present invention about an obstruction in a vessel. The figures are intended to demonstrate the initial placement of the device immediately prior to removal of the obstruction.

[0118] Fig. 6A illustrates an obstruction **2** lodged within a body lumen or vessel **6**. In the case where the vessel is a cerebral artery, the obstruction may result in an ischemic stroke. Using standard interventional catheterization techniques, a microcatheter **102** and guidewire **104** traverse the obstruction. The microcatheter **102** may be advanced through the obstruction **2**. Alternatively, the microcatheter **102** may “push” aside the obstruction and is advanced around the obstruction. In any case, the microcatheter **102** travels from the near end **3** (or proximal side) of the obstruction **2** to the far end **4** (or distal side) of the obstruction **2**. It is noted that the catheter **102** may be centered or off-center with respect to the obstruction **2**. Furthermore, the device may or may not be used with a guidewire to navigate to the site and traverse the obstruction.

[0119] Some variations of the device may be placed without an accompanying guidewire. Moreover, the structures discussed herein may be directly incorporated into a guidewire assembly where deployment may require a sheath or other covering to release the components from constraint.

[0120] Fig. 6B illustrates deployment of a capturing portion **226** and main bundle **202** of the device **200** from within the microcatheter **102** distal to the obstruction **2**. Accordingly, in most variations, the capturing portion **226** is designed to fit within the catheter **102** for delivery and expand upon deployment. Alternatively, the device may be actuated to assume the desired shape (e.g., upon reaching a transition temperature where one or more wires comprise a shape memory alloy). As shown, the capturing portion **226** includes a traversing section **234** and a capturing section **232**. In some procedures the traversing section **234** engulfs the obstruction **2** with little or no complication as the main bundle **202**, catheter **102**, or sheath **106** pulls the capturing portion **226** in a proximal direction.

[0121] However, as discussed above, there may be some procedures where the distal capturing portion **226** is deployed distal to an obstruction **2** that is deposited within the vessel or lumen such that a steady translation of the capturing portion **226** will not engulf the obstruction **2**. Figs. 7A to 7G illustrate some examples of such a situation. As shown in Fig. 7A, a sheath **106** might be able to traverse the obstruction **2** to deploy the distal capturing portion **226** in preparation for engulfing the obstruction **2**. Fig. 7B illustrates a condition where the traversing section **234** engages the obstruction **2** but is unable to easily or fully engulf the obstruction **2**. However, in those variations where the capturing portion **226** includes regions

having different axial strength (as discussed above), continued pulling of the main bundle **202** in a proximal direction **120** causes the capturing section **234** to compress. When the capturing section **234** is constructed to function as spring, the deformation of the capturing section **232** stores energy from the proximal movement of the main bundle **202**. This storing of energy allows the physician to relax the pulling force **120** on the main bundle **202**. Fig. 7C shows a compressed capturing section **234**. The energy stored in the capturing section **232** gradually drives the open proximal end **228** of the translating section **234** over or along the obstruction **2**. The physician can apply this “pull and relax” technique repeatedly until the obstruction is sufficiently captured by the capturing portion **226**. In some variations, the capturing section **234** remains compressed as the obstruction **2** finally breaks loose and removed.

[0122] Fig. 7D represents the situation where a distal capturing portion distal to an object **2** that is significantly embedded within a vessel or body lumen. In such cases, the force required to remove the obstruction **2** may damage the vessel or lumen. Such obstructions include atherosclerotic plaque or other immobile objects. As shown, when the distal capturing portion **226** is pulled once the proximal force **120** reaches a threshold value (as determined by the construction of the capturing portion **226**) the capturing portion **226** undergoes a staged inversion as the permeable end **230** enters the traversing section **232**. In this variation, the permeable end **230** actually enters the obstruction **2**. The construction of the capturing portion **226** prevents flattening or expanding in diameter, where such movements would prevent removal of the capturing portion. Again, if the force applied by the capturing portion **226** breaks the obstruction **2** free. The obstruction **2** can be removed even though a part of the capturing portion **226** is within the obstruction **2** as shown in Fig. 2D.

[0123] Fig. 7E shows advanced inversion of the capturing portion **226** as the capturing section **234** is now proximal to the traversing section **232**. The traversing section **232** may be deformed upon inversion but will taper towards the capturing section **234** as the capturing section **234** passes through the obstruction **2** (typically via an opening that was previously created by advancement of a sheath **106** through or around the obstruction **2**).

[0124] Fig. 7F shows the capturing portion **226** nearly passing through the obstruction **2** so that it may be removed from the body. As shown in Fig. 7G, the

capturing portion **226** is now fully inverted and is in a state where it can re-enter a catheter for removal from the patient.

[0125] The construction described herein that allows for staged inversion of the capturing portion **2** provides a significant safety feature. A physician must undertake additional surgical intervention to remove any retrieval device that has become lodged distally to an immobile obstruction. The ability of staged inversion allows the physician to invert and remove the capturing portion **226** if application of a predetermined or threshold force is exceeded by proximal displacement of the device. This feature reduces the need for additional surgical intervention to remove a retrieval device that would otherwise become lodged or separated as a result of excessive forces being applied.

[0126] Figs. 8A to 8B illustrate an additional benefit of affixing a leading wire or bundle of wires **202** beyond a proximal opening **228** of a capturing portion **226**. Fig. 5A illustrates a basket type structure **90** where a wire **202** is affixed to a proximal end **92**. As shown, as the leading wire **202** pulls the basket **90** through tortuous anatomy **6**, the force component pulling away from an axis of the device **90** causes the proximal open end **92** to constrict or reduce in size. As shown, as the proximal end **92** approaches the obstruction **2** the perimeter of the end is not placed against the walls of the body passage **6**. As a result, the constricted opening **92** places an increased axial force on the obstruction **2** as the basket **90** translates over the obstruction **2** (because the proximal end **92** pushes against the obstruction rather than sliding around it), making encapsulation of the obstruction more difficult and possible leading to vascular damage.

[0127] Fig. 8B shows a device **200** according to the principles disclosed herein. The leading wire **202** is affixed to the distal end **230** of the capturing portion **226**. As the main bundle **202** is pulled through the curved vascular path, the capturing portion **226** pivots or articulates about the bundle **202** and remains aligned with the axis of the vessel. As a result any misalignment between the leading wire **202** and an axis of the capturing portion **226** does not affect the open proximal end **228**. As noted above, some closing of the open proximal end may occur, though it will not be sufficient to interfere with the obstruction as the capturing portion moves over the obstruction. Such a configuration allows the perimeter of the open proximal end **228** to remain against the wall of the passage **6**. As shown, because the open

proximal end **228** is not constricted, the open proximal end **228** is better suited to slide around the obstruction for eventual removal.

[0128] Fig. 8C shows withdrawal of the microcatheter **102** to the proximal side **3** of the obstruction **2** and deployment of a proximal capturing portion **260** (in alternate variations, a proximal foot can be used or the capturing portion **226** alone can be used). Again, the catheter **102** can be exchanged for a catheter **102** having a proximal capturing portion **260**. Alternatively, and as shown in the accompanying figures, the proximal capturing portion **260** can be affixed to a delivery sheath **106** that is fed through the microcatheter **102**.

[0129] As also shown in the figure, the main bundle **202** and capturing portions become misaligned due to the tortuosity of the anatomy. However, because the capturing portions **226** and **260** are able to pivot or articulate relative to the main bundle **202** and catheter **102** or sheath **106**, the open ends are able to remain against the lumen wall. In conventional devices where the open end is attached to either a wire or catheter, when the wire or catheter bends in the anatomy, the forces exerted on the open ends deform or distort the end to assume a reduced profile. Accordingly, the physician may have difficulty in removing an obstruction if the profile of the open end becomes reduced in size. Closing of the open end can also result in vascular damage if the physician applies too much force in translating the device.

[0130] Fig. 8D shows movement of the capturing portions **226** and **260** adjacent to the obstruction **2**. The proximal capturing portion **260** can remain stationary or may be advanced relative to the distal capturing portion **226**. Regardless, the physician is able to ensnare the obstruction **2** within the cavities defined by the capturing portions **226** and **260**. Fig. 8E illustrates the system as the two capturing portions are drawn together. For purposes of clarity, the obstruction is not shown. Upon sufficient advancement of the capturing portion **226** and proximal capturing portion **260** relative to one-another, flanges **238** on the respective open ends can interlock. This feature provides added safety in removing the device as the obstruction is encapsulated between the two nested portions.

[0131] Fig. 8F illustrates a device **200** after securing an obstruction between a proximal **260** and distal **226** capturing sections. As shown, the captured obstruction **2** is held between capturing portions **226** and **260** where the flanges **238** nest within one-another to "lock" the capturing portions together. In some

variations of the device, one of the capturing portions can be undersized relative to the other. This configuration allows for the undersized capturing portion to become further compressed as the devices are pulled together. The compression of the capturing surface then serves to further compress the obstruction **2** captured within the device.

[0132] The capturing portions described herein can include coverings or wrappings so long as the other features of the device are not impaired. Such coverings can be located on both capturing portions **226** and **260**, only one or more capturing portions. The covering can include a strand or fiber wrapped or woven about the section, a polymer film, or a dipped polymer coating such as silicone, urethane, etc. The coating on either capturing portion can be solid or porous. In the latter case, blood can continue to flow through the coating. In one variation, the proximal capturing portion **260** could employ a solid covering while the distal capturing portion **200** could include a porous covering. In such a case, blood or other fluid flow could be temporarily halted by the presence of the solid covering to assist in removal of the obstruction.

[0133] Fig. 9 illustrates a variation of the system where the main bundle **202** includes a medial foot **274**. The construction of the medial foot **274** can be similar to that of the proximal foot discussed above (e.g., wires looped into a petal configuration.) However, the medial foot includes a surface area or diameter larger than a diameter of the main bundle. In any case, the increased surface area of the medial foot **274** provides an increased resistance to the obstruction **2** as the distal capturing portion **200** and main bundle **202** are pulled in a proximal direction towards an obstruction **2**. The medial foot **274** engages the obstruction **2** to partially displace or loosen the obstruction from the walls of the body passage. The medial foot **274** can be slidably located on the main bundle such that after a threshold force, the medial foot moves within the distal capturing portion **200**. The main bundle **202** can include any number of medial feet **274**.

[0134] Although the illustrated variation shown above comprise open-ended, circular, looped or partial loop shape cross sectional areas, variations of the capturing portions can include any number of shapes. For example, such a shape can include a circle, an arcuate shape, a partial circular shape, a loop, an oval, a square, a rectangle, a polygon, an overlapping loop, a pair of semi-circles, etc.) The various shapes may be heat set to be either self-expanding (i.e., superelastic)

or the use of shape memory alloys can allow for the device to assume the particular shape upon reaching a desired transition temperature.

[0135] The exemplary shapes discussed above permit the shaped section to adjust in diameter in response to placement in varying diameters of body lumens. It is noted that a device may have different shaped sections on different ends of the device.

[0136] While many different shapes are contemplated to be within the scope of this disclosure, the shapes will depend upon the ultimate application of the device. As noted herein, the illustrated examples have particular applicability in retrieving obstructions from the vasculature. Accordingly, for these applications the shaped sections should form a shape so that they can expand against a vessel wall without causing trauma to the vessel. For example, upon release from the catheter, the shaped section can assume their resting shape and expand within the vessel. The resting shape can be constructed to have a size slightly greater than that of the vessel. Sizing the device relative to the target vessel may assist in placing the parts of the device against a vessel.

[0137] In an additional aspect, the shaped sections may be designed to have an unconstrained shape that is larger than the intended target vessel or simply different than a cross sectional profile of the intended vessel (i.e., not circular or tubular, but e.g., linear or other different shape). In such an example, as the shaped section is released from the delivery catheter, the shape section attempts to return to the unconstrained shape. In those variations where the unconstrained shape is different from the circular profile of the vessel, the leading wire assumes a shape that accommodates the vessel but is more rigid and stable since its unconstrained shape is entirely different from that of the vessel. In other words, the shaped section continually exerts an outward force on the vessel.

[0138] In yet another aspect, the shaped sections shown herein may not necessarily lie in the same plane. Instead, they can be axially spaced by an offset. One benefit of constructing the device to have non-planar shaped section is that the configuration might allow for delivery of the device through a smaller microcatheter because the shaped sections do not interfere with one another when collapsed to fit within the microcatheter.

[0139] Another aspect applicable to all variations of the devices is to configure the devices (whether the traversing filament or the surrounding portion) for better

adherence to the obstruction. One such mode includes the use of coatings that bond to certain clots (or other materials causing the obstruction.) For example, the wires may be coated with a hydrogel or adhesive that bonds to a thrombus. Accordingly, as the device secures about a clot, the combination of the additive and the mechanical structure of the device may improve the effectiveness of the device in removing the obstruction. Coatings may also be combined with the capturing portions or catheter to improve the ability of the device to encapsulate and remove the obstruction (e.g., a hydrophilic coating).

[0140] Such improvements may also be mechanical or structural. Any portion of the capturing portion can have hooks, fibers, or barbs that grip into the obstruction as the device surrounds the obstruction. The hooks, fibers, or barbs **154** can be incorporated into any portion of the device. However, it will be important that such features do not hinder the ability of the practitioner to remove the device from the body.

[0141] In addition to additives, the device can be coupled to an RF or other power source (such as **14** or **16** in Fig. 1A), to allow current, ultrasound or RF energy to transmit through the device and induce clotting or cause additional coagulation of a clot or other the obstruction.

[0142] The methods described herein may also include treating the obstruction prior to attempting to remove the obstruction. Such a treatment can include applying a chemical or pharmaceutical agent with the goal of making the occlusion shrink or to make it more rigid for easier removal. Such agents include, but are not limited to chemotherapy drugs, or solutions, a mild formalin, or aldehyde solution.

[0143] As for other details of the present invention, materials and manufacturing techniques may be employed as within the level of those with skill in the relevant art. The same may hold true with respect to method-based aspects of the invention in terms of additional acts that are commonly or logically employed. In addition, though the invention has been described in reference to several examples, optionally incorporating various features, the invention is not to be limited to that which is described or indicated as contemplated with respect to each variation of the invention.

[0144] Fig. 10 illustrates one variation of a retrieval device **200** including a distal capture portion **226** coupled to one or more leading wires in the form of a main bundle **202**. The main bundle extends through a sheath **106** that includes a

proximal capture portion **260**. The configuration of the retrieval device **200** can incorporate the proximal and distal capture portions discussed herein as well as various other configurations discussed in the commonly assigned patent applications noted above. In addition, the relative sizes of the various components shown in Fig. 10 and discussed below are for illustrative purposes only.

[0145] An end **264** of the proximal capture portion **260** is affixed to a distal end of the sheath **106**. However, as noted above, other variations are within the scope of the disclosure. The main bundle **202** can optionally terminate at a handle **242**. As noted above, in certain variations, the main bundle is joined to a stiffer wire or stiffer bundle of wires. This allows the device **200** to have a very flexible distal section with a relatively stiffer proximal section. Fig. 4A above, discusses placement of a joint at a location spaced from the distal section of the device so as to increase a bond strength but not impair the distal section's flexibility. In any case, the device **200** can have a proximal bundle **203** that comprises either the exposed wires or a covering/tube over the wires. In certain variations, the bundle or wire **202, 203** can be encapsulated with a coating.

[0146] The proximal end of the sheath **106** includes a sheath handle **244**. As discussed herein, axial movement of the bundle **202** or proximal bundle **203** (typically at the handle **242**) results in movement **126**, or translation of the bundle within the sheath **106**. This action moves the distal capture portion **226** (as shown by arrows **126**). In certain variations, the device **200** is loaded into a microcatheter (not shown but discussed above) that is delivered to the site of the obstruction and crosses the obstruction.

[0147] In some variations, the sheath hub **244** includes one or more locking hubs **246**. Where actuation (either axial or rotational) of the locking hub **246** locks the main bundle **202** relative to the sheath handle **244** and sheath **106**. It follows that such locking action also locks the distal capture portion **226** relative to the proximal capture portion **260**. A variety of methods can be employed to increase a frictional interference between the locking hub **246** and the proximal bundle **203**. As a result, when a physician determines a length of an obstruction, the physician can set a spacing between the capturing portions **226 260** by locking the proximal bundle **203** relative to the sheath hub **244**. Accordingly, the proximal bundle **203** can include any type of incremental markings to allow the physician to readily determine a spacing of the capturing portions. As illustrated, the sheath hub **244**

can include additional injection ports to deliver fluid or other substances through the sheath **106**.

[0148] As noted above, the device **200** can be used with micro-catheter. In those variations it is important that the device **200** is loaded without damaging the distal bundle **202**, capture portions **226 260**, and/or sheath **106**. As a result, the device **200** can include an optional funnel **286** that reduces the proximal capture portion **260** (and /or the distal capture portion **226**) for loading within the microcatheter and/or sheath **106**.

[0149] Another variation of the device **200** includes an insertion tool **280** slidably affixed to the sheath **280**. Because variations of the device **200** can be extremely flexible, the insertion tool **280** can be used to provide column strength to the sheath **106**, bundle **202** or other components as the device **200** is pushed into the microcatheter. The insertion tool comprises a rigid section **282** and a frictional coupler **284**. The rigid section **282** has a column strength that supports the device **200** to prevent buckling. The frictional coupler **284** can be a flexible material that allows an operator to squeeze or grip the coupler **284** to create a temporary frictional interface between the loading tool **280** and the device **200** (typically the sheath **106**). Such an action allows axial advancement of the device **200** as the loading tool **280** is advanced into the microcatheter. Once the rigid section **282** is fully inserted into the microcatheter, the operator releases the frictional coupler **284** and can withdraw the loading tool **280** from the catheter without withdrawing the device **200**. The insertion tool **280** can also include an optional loading tube **286** slidably coupled to the rigid section **282**. When used, the funnel **286** can withdraw the proximal and distal capturing portion **226 260** within the loading tube **286**. The loading tube **286** then couples to a microcatheter allowing the capturing portions to advance therein as the rigid section **282** and frictional coupler **284** advance the device **200** relative to the loading tube **286**.

[0150] Fig. 11A illustrates a funnel catheter **300** useful for retrieving objects from vessels or body lumens. Typically, when a physician captures an obstruction in various retrieval devices, the device and the obstruction are easily removed from the body by withdrawing the device and obstruction into a sheath, guide catheter or introducer ("guide catheter"). However, in some circumstances, a physician has difficulty withdrawing the obstruction loaded device within a sheath, guide catheter or introducer. Specifically, one or more components of the retrieval

device might become caught on an edge of the guide catheter. The concern may still remain even when using a guide catheter having an increased diameter (such as when the retrieval device catches on one edge of the guide catheter tip).

Moreover, large guide catheters are difficult to advance within various parts of the anatomy. As a result, the obstruction loaded device must travel further.

Movement of the obstruction loaded device within the body creates the risk that the obstruction will detach or break apart and cause additional adverse consequences.

[0151] The funnel catheter **300** includes a first and second slotted funnels **330**, **340** located at the distal end of an inner shaft **302**. Each funnel **330** **340** comprises a number of extensions or tines **332** **342**. The inner shaft **302** can be cut to produce the first tines **332**. Alternatively, the first tines **332** can be affixed to a portion of the inner shaft **302**. The second slotted funnel **340** is offset in both a proximal and rotational position relative to the first slotted funnel **330**. The purpose of this dual offset is discussed in detail below. As shown, the second funnel **340** can be a slotted tube that is affixed over the inner shaft **302**. In an alternate variation, a plurality of second tines **342** can be located about the inner shaft **302** to form a second slotted funnel **340**. As shown in Fig. 11B, the tines **332** **342** can be configured to expand outward (if not restrained) via use of a coil or other spring-type means. Alternatively, they can be actuated to expand outward. However, in most cases, the tines **332** **342** can expand passively upon entry of the retrieval device **200**. The expansion of one or both funnels assists in receiving the retrieval device. In additional configurations, one or more funnels can be designed so that they remain in a cylindrical shape rather than expand outwards (as shown in Fig. 11C). Variations of the funnel catheter **300** can include configurations having one or more funnels, or configurations where the tines spaced or adjacent (or a combination thereof).

[0152] Fig. 11C also illustrates the dual offset nature of the dual funnel catheter **300**. The first offset is a linear offset **316** such that the distal ends of the first tines **332** or funnel **330** extends beyond a distal end of the second tines **342** or second funnel **340**. The second offset comprises a rotational offset (denoted by rotational angle **A**). For example, the illustrated rotational offset **A** is 45 degrees. However, the rotational offset can vary depending on the particular application. In most variations, the rotational offset **A** will place the second tines **342** over the gaps or spaces between the first tines **332**. The number of tines can vary depending on the

application. Variations of the funnel catheter can include discontinuous funnels with two or more tines.

[0153] Turning back to Fig. 11A, the funnel catheter **300** can optionally include any number of medical fittings or components. As shown, the catheter **300** includes a hemostasis valve or hub **306** at the proximal end. The hemostasis valve **306** can include a fluid side port **308** for delivery of fluid through the catheter **300**. The catheter **300** can also include one or more radiopaque markers **310** so that the location of the funnel or funnels **330 340** can be identified via non-invasive imaging (e.g., under fluoroscopy). The funnel catheter **300** can also optionally include one or more markers **312**. Such markers are useful to inform a physician (who is only able to view the proximal end of the device **300**) of the distance to the first or second funnel. As a result, the physician will be able to determine whether the funnels are advanced out of the guide catheter. Fig. 11A also shows the funnel catheter **300** as including a loading tool **314**. The loading tool **314** can be advanced over the funnels **330 340** to compress the funnel when loading into a guide catheter or other sheath.

[0154] Figs. 12A to 12C provide an illustrative example where use of a funnel catheter **300** aids in removal of an obstruction **2** loaded within a retrieval device **200**.

[0155] As shown in Fig. 12A, attempting to remove the obstruction **2** when engulfed in the retrieval device **200** creates a risk that one or more portions of the device **200** become caught on the guide sheath or access catheter **108**. In some cases, the physician can simply engage the device **200** against the distal end of the guide sheath **108** and withdraw until the obstruction **6** and device **200** are located in an acceptable area of the body or withdrawn entirely from the body. For example, in certain situations, the obstruction **6** and device **200** can be withdrawn with the guide sheath **108** until all components reach a high flow, non-critical locations (e.g., the groin area). In the case of a clot, a clot dissolving substance (TPA) can then be applied to dissolve and remove the clot. Alternatively, the physician can attempt to aspirate through the guide sheath **108** in an attempt to draw the entire retrieval device **200** and obstruction **2** within the guide sheath **108**. In yet another variation, the physician can advance fibers or guide wires out through the guide sheath **108**, then withdraw the obstruction **2**/retrieval device **200** and attempt to use the fibers or guide wires as a moveable surface to capture the

device **200**. Furthermore, the physician can attempt to use a variety of existing devices (e.g., the FastCath provided by Genesis Medical Inc., the Merci Retriever provided by Concentric Medical Inc., or any commercially available snare or distal protection device) to remove the engulfed obstruction **2** from the body.

[0156] In some variations, the capturing portions discussed above can be constructed to improve their ability to be withdrawn into a guide sheath. For example, increasing the number of petals or flanges on the traversing sections increases the probability that the distal flanges nest within the proximal capturing portion. Alternatively, or in combination, the petals **238** on the distal capturing portion can be staggered in length or position to ease insertion into the proximal capturing portion. In another variation, the petals **238** shape or curvature can be adjusted so that they do not flare outward.

[0157] Fig. 12B shows a distal end of a funnel catheter **300** as it receives an obstruction **2** loaded retrieval device **200**. As shown, the tines **332** of the first funnel **330** receive the device **200**. The tines **332** minimize the likelihood that the device **200** becomes caught. The limited surface area of the tine **332** (combined with the rounded tines **332 342**) produces a tendency for the device **200** to deflect away from the tines as it is withdrawn into the funnels. The second funnel **340** (being rotationally offset from the first funnel **330**) provides coverage over the spaces between the first tines **332** thereby assisting in nesting of the device **200** within the funnels. Ultimately, the device **200** and obstruction **2** are withdrawn into a guide sheath **108** and removed from the body.

[0158] Figs. 12 C to 12D show additional variations of funnel catheter **300**. Fig. 12C shows a single funnel **330** having a plurality of tines **332**. Fig. 12D illustrates a dual funnel catheter **300** having a discontinuous first funnel **230** and a second funnel **346**. The second funnel **346** can be a continuous funnel so long as it is able to retract within the guide sheath **108**. As shown, the second funnel **346** can include a single slit **348** that allows the funnel to compress within the guide sheath **108**. In addition, the variation of Fig. 12D can be used without the first discontinuous funnel **330**. Accordingly, as the retrieval device **200** and clot **2** approach the funnel **346** and enters the funnel, further withdrawing the retrieval device **200** causes squeezing of the retrieval device **200** and obstruction **2**. In yet another variation, the funnel **346** can incorporate a drawstring to compress the funnel **346** once the retrieval device **200** and obstruction are located therein.

[0159] Fig. 13A to 13B illustrates another variation of a funnel catheter 350 suited to remove a retrieval device 200 from the body. As shown in Fig. 13A, the funnel catheter 350 includes a first shaft 352 and a second shaft 354 slidably located therein. A mesh 370 is fused to each shaft 352 354 at a distal location 362 364. Accordingly, relative movement of the shafts 352 354 (either the first shaft 352 can be pushed or the second shaft 354 can be pulled) creates a funnel shape 372 as the mesh portion affixed to the second shaft 354 is inverted within the remainder of the mesh 370. It is noted that in some variations of the system, the mesh funnel funnels are combined with the tine based funnels described above. Such that one funnel comprises the tines while the other comprises the mesh structure described herein.

[0160] In another variation, a third distally located capture portion (similar to a distal capture portion) can be used to draw the retrieval device within a guide sheath. In such a variation, the third capture portion can be a larger distal capture portion and when the retrieval device engulfs an obstruction, the third basket portion can be proximally withdrawn to capture the retrieval device and obstruction.

[0161] As illustrated in Fig. 13B, as the retrieval device 200 and obstruction 2 approach the funnel catheter 350, the distal attachment points 362 364 of the shafts 352 354 are moved together to invert the mesh 370 and form a funnel 372. The retrieval device 200 can then be withdrawn into the funnel. This design allows for the retrieval device 200 to be fully withdrawn into the catheter 350 while the funnel 372 is expanded. Alternatively, the funnel 372 can be used to compress the retrieval device 200 and obstruction 2 prior to withdrawal into the catheter 350.

[0162] The mesh 370 can include any medically acceptable material such as a nitinol braid. Furthermore, the mesh allows for flow through the vessel or lumen while expanded. However, additional variations of the device can include a solid layer of material substituted for the mesh.

[0163] Figs. 13C to 13E illustrate another variation of a funnel catheter 350 suited to remove a retrieval device 200 from the body. As shown in Fig. 13C, the funnel catheter 350 includes a first shaft 352 and a second shaft 354 slidably located therein. A mesh 370 is joined only the rear shaft 354 at a distal location 362. The end of the mesh 370 is free at the distal end of the device 350. The mesh 370 is sized at a distal end 371 to neck down. Accordingly, as the distal shaft moves

rearward, the mesh 370 is unsupported. The necked section 371 of the mesh allows for distal advancement of the device 200 through the neck portion 371. However, as shown by Fig. 13D, rearward movement of the device 200 causes engagement with the neck portion 371. Further rearward movement of the device 200 causes the unsupported mesh 370 to form a funnel shape 372 as shown in Fig. 13E. The funnel shape allows for the retrieval device 200 to be fully withdrawn into the catheter 350 while the funnel 372 is expanded. Alternatively, the funnel 372 can be used to compress the retrieval device 200 and obstruction 2 prior to withdrawal into the catheter 350. To compress the funnel, the device 200 can be advanced out of the funnel and away from the mesh 370. Next, the distal shaft 352 can be advanced through the neck portion 371 of the mesh 370 to receive the device 200. In another variation, the device 350 can include a single shaft 354 where the mesh 370 can extend beyond the shaft 354. The mesh can be heat set to assume a funnel shape upon the application of a current or as it reaches body temperature. In another variation, the mesh 370 can comprise a super-elastic material that assumes the shape shown in Fig. 13E when released from a constraining member.

[0164] Figs. 13F to 13G illustrate yet another variation a funnel catheter 350 suited to remove a retrieval device 200 from the body. In this variation, the funnel catheter 350 includes a single shaft 354 having a mesh 370 is fused to a distal location 364. The mesh 370 is free at a proximal side. The mesh is also pre-formed to assume a funnel shape as shown in Fig. 13G. Accordingly, upon delivery the mesh 370 can be constrained (e.g., via a sheath, or other removable restraint). Once the restraint is removed, the mesh 370 expands to form a funnel 372.

[0165] Figs. 14A to 14D illustrate additional concepts for use with various retrieval devices 200. Fig. 14A illustrates a distal capturing portion 226 and a proximal capturing portion 260 where the proximal capturing portion includes a covering 212 (e.g., a polymeric covering or a wire or fiber wound about the flanges 238). The covering 212 prevents the flanges 238 of the distal capturing portion 226 from flaring outside of the proximal capturing portion 260.

[0166] Fig. 14B illustrates a variation of a reentry sleeve where tines 332 of the reentry sleeve 302 include protrusions 214 on an inner surface. The protrusions 214 cause the tines 332 to splay out as the retrieval device 200 is withdrawn within

the tines **332**. As the reentry sleeve **302** is withdrawn in a guide catheter (as discussed above) the protrusions serve to compress the retrieval device **200** even further.

[0167] Fig. 14C and 14D illustrate variations of a wire or fiber **218** affixed to the flanges **238** of a distal capturing portion **226** to assist in compressing the flanges **238** prior to entry within a guide sheath. As shown in Fig. 14C the fiber **218** can be affixed to a suture ring **216**. As the fiber **218** is pulled, the suture ring **216** compresses the flanges **238** to prevent outward flaring. In Fig. 14D, one or more fibers **218** are affixed to one or more flanges **238**. Once the obstruction is captured, the fibers can be pulled to draw the flanges **238** closed.

[0168] Various changes may be made to the invention described and equivalents (whether recited herein or not included for the sake of some brevity) may be substituted without departing from the true spirit and scope of the invention. Also, any optional feature of the inventive variations may be set forth and claimed independently, or in combination with any one or more of the features described herein. Accordingly, the invention contemplates combinations of various aspects of the embodiments or combinations of the embodiments themselves, where possible. Reference to a singular item, includes the possibility that there are plural of the same items present. More specifically, as used herein and in the appended claims, the singular forms "a," "and," "said," and "the" include plural references unless the context clearly dictates otherwise.

[0169] It is important to note that where possible, aspects of the various described embodiments, or the embodiments themselves can be combined. Where such combinations are intended to be within the scope of this disclosure.

CLAIMS

We claim:

1. A medical device for removing an obstruction from a blood vessel, the medical device comprising:
 - a main bundle comprising a group of wires having a first end and a second end;
 - a capturing portion formed by the group of wires and having a translating surface adjacent to a capturing surface, the translating surface having an open proximal end and the capturing surface having a permeable distal end;
 - where the capturing portion is formed from the group of wires such that the group of wires diverges from the second end of the main bundle to form the permeable distal end, the group of wires extend back in a proximal direction to form the capturing surface, the translating surface, and open proximal end about the main bundle; and
 - where the translating surface and capturing surface are configured so that a translating surface axial strength is greater than a capturing surface axial strength, wherein application of a tensile force on the main bundle causes axial compression of the capturing surface without causing axial compression and deformation of the translating surface sufficient to deform the translating surface as the capturing portion engages the obstruction.
2. The medical device of claim 1, where the capturing portion is formed such that articulation of the capturing portion relative to the main bundle does not cause the open proximal end to reduce in size.
3. The medical device of claim 1, where the capturing surface is configured to generate a spring force against the translating surface when a proximal force applied by the main bundle of wires compresses the capturing surface against the translating surface when encountering resistance from the obstruction, where the capturing surface is configured to have a sufficient axial stiffness to direct the spring force and proximal force to the open proximal end as the open proximal end engages the obstruction where the capturing surface is also sufficiently flexible to conform to a shape of the vessel.

4. The medical device of claim 1, where the capturing section is configured so that when the open proximal end of the translating section engages resistance equal to or greater than a threshold force, proximal movement of the main bundle inverts the capturing section within the translating section and reduces a size of the capturing section.
5. The medical device of claim 4, where the capturing section and traversing section are configured to invert upon continued proximal movement of the main bundle such that the traversing surface moves distally to the capturing surface.
6. The medical device of claim 1, where the main bundle is joined to a proximal bundle, where the proximal bundle comprises a stiffness greater than the main bundle and where the main bundle extends for a pre-determined distance from the permeable distal end to allow navigation of a distal portion of the medical device within the cerebral vasculature.
7. The medical device of claim 6, where the pre-determined distance is at least 20 cm.
8. The medical device of claim 1, where the capturing surface has an increased frictional resistance as compared to the translating surface, such that the capturing surface engages the obstruction for removal of the obstruction.
9. The medical device of claim 1, where the open proximal end further comprises a plurality of flanges extending from the translating surface.
10. The medical device of claim 9, where the flanges extend radially away from an axis of the capturing portion.
11. The medical device of claim 1, where the capturing portion is self-expandable.
12. The medical device of claim 1, where at least a portion of the capturing surface comprises a structure selected from the group consisting of a basket, a filter, a bag, a coil, a helical wire structure, a mesh, a single wound wire, and a plurality of crossing wires or a combination thereof.

13. The medical device of claim 1, where the main bundle of wires includes at least a first wire and a second wire where the first and second wire each have different characteristics.
14. The medical device of claim 13, where the characteristics are selected from a group consisting of material, cross-sectional shape, and cross-sectional size.
15. The medical device of claim 1, where the main bundle of wires includes at least one shape memory alloy wire.
16. The medical device of claim 1, where the main bundle of wires includes at least one wire selected from the group consisting of a superelastic wire, a polymeric wire, or a metal alloy.
17. The medical device of claim 16, where the metal alloy comprises an alloy selected from the group consisting of stainless steel, titanium, platinum, gold, iridium, tantalum, nitinol, and combinations thereof.
18. The medical device of claim 1, further comprising at least one radiopaque material located on the capturing portion.
19. The medical device of claim 1, where the individual wires in the group of wires each comprise a bundle of smaller wires.
20. The medical device of claim 1, where the individual wire comprises a super-elastic outer shell and an inner core of a radiopaque material.
21. The medical device of claim 20, where the inner core comprises a material selected from a group consisting of platinum, iridium, gold, and tantalum.
22. The medical device of claim 1, where the capturing portion is jointless.
23. The medical device of claim 1, where at least one of the wires from the main bundle returns to the main bundle after forming at least a part of the capturing portion.
24. The medical device of claim 1, where each of the wires from the main bundle returns to the main bundle after forming a part of the capturing portion.

25. The medical device of claim 1, where the main bundle is surrounded by a coil or coiled wire.
26. A retrieval device for removing an obstruction from a body lumen, the retrieval device comprising:
at least one leading wire;
a retrieval body comprising a translating section adjacent to a capturing section, the translating section having an open proximal end and the capturing section having a permeable distal end, where the leading wire extends to a portion of the capturing section to permit articulation of the open proximal end relative to the leading wire; and
where the translating section and capturing section are configured so that a translating section axial strength is greater than a capturing section axial strength, wherein application of a tensile force on the leading wire causes axial compression of the capturing surface without causing axial deformation of the translating surface when the retrieval body engages the obstruction.
27. The retrieval device of claim 26, where the retrieval body is formed such that articulation of the retrieval body relative to the leading wire occurs without narrowing of the open proximal end during articulation.
28. The retrieval device of claim 26, where the capturing section is configured to generate a spring force against the translating section when a proximal force applied by the leading wire compresses the capturing section against the translating section when encountering resistance from the obstruction, where the capturing section is configured to have a sufficient axial stiffness to direct the spring force and proximal force to the open proximal end as the open proximal end engages the obstruction, where the capturing section is also sufficiently flexible to conform to a shape of the body lumen.
29. The retrieval device of claim 26, where the capturing section is configured so that when the open proximal end of the translating section engages resistance equal to or greater than a threshold force, proximal movement of the leading wire inverts the capturing section within the translating section and reduces a size of the capturing section.

30. The retrieval device of claim 29, where the capturing section and traversing section are configured to invert upon continued proximal movement of the leading wire such that the traversing section moves distally to the capturing section.

31. The retrieval device of claim 26, where the at least one leading wire is joined to at least one proximal leading wire, where the proximal leading wire comprises a stiffness greater than the leading wire and where the leading wire extends for a pre-determined distance from the permeable distal end to allow navigation of a distal portion of the retrieval device within the cerebral vasculature.

32. The retrieval device of claim 31, where the pre-determined distance is at least 20 cm.

33. The retrieval device of claim 26, where the leading wire is surrounded by a coil or coiled wire.

34. The retrieval device of claim 26, where the leading wire extends to the permeable distal end.

35. The retrieval device of claim 26, where the capturing portion comprises a structure selected from a group consisting of a laser cut tube, an etched tube, an injection molded structure.

36. The retrieval device of claim 36, where the at least one leading wire is attached to the capturing portion via a joint or junction.

37. The retrieval device of claim 26, where the translating section has a low coverage density relative to the capturing section, thereby lowering frictional resistance of the first portion of the capturing surface when moving over the obstruction.

38. The retrieval device of claim 37, where the at least one leading wire comprises a super-elastic outer shell and an inner core of a radiopaque material.

39. The retrieval device of claim 38, where the inner core comprises a material selected from a group consisting of platinum, iridium, gold, tantalum, alloys or mixtures thereof.

40. The retrieval device of claim 38, where leading wire is continuous with and forms the capturing portion.

41. The retrieval device of claim 26, where the at least one leading wire comprises a group of wires forming a main bundle and where the group of wires forms the capturing portion such that the group of wires diverges from a second end of the main bundle to form the permeable distal end, the group of wires continue to extend to form both the capturing surface and open end.

42. The retrieval device of claim 26, where the at least one leading wire comprises a group of wires forming a main bundle and where the group of wires forms, the capturing portion such that the group of wires diverges from a second end of the main bundle to form the capturing surface, the group of wires continues to extend to form both the permeable distal end and open proximal end.

43. The retrieval device of claim 26, where the at least one leading wire comprises a group of wires forming a main bundle and where at least one individual wire has a cross-sectional shape selected from the group consisting of a circle, an oval, a rectangular shape, a polygon, and a D-shape.

44. The retrieval device of claim 26, where the retrieval body is jointless.

45. The retrieval device of claim 26, where at least a portion of the capturing section comprises a structure selected from the group consisting of a basket, a filter, a bag, a coil, a helical wire structure, a mesh, a single wound wire, a plurality of crossing wires, and a combination thereof.

46. The retrieval device of claim 26, where the open proximal end of the translating section further comprises a plurality of flanges extending from the capturing portion

47. The retrieval device of claim 26, where the retrieval body is self-expandable and compresses to fit within a lumen of a catheter.

48. The retrieval device of claim 26, further comprising at least one radiopaque material located on the capturing section.

49. The retrieval device of claim 26, where the leading wire comprise a bundle of smaller wires.
50. The retrieval device of claim 26, where the leading wire comprises a group of wires that diverges towards the permeable distal end of the capturing section.
51. The retrieval device of claim 26, further comprising a proximal capturing portion where the retrieval body is moveable relative to the proximal capturing portion, where the proximal capturing portion comprises an open distal end and a proximal end, where the leading wire extends through the open distal end of the proximal capturing portion, and is moveable relative to the proximal capturing portion such that a distance between the distal open end of the proximal capturing portion and the proximal open end of the retrieval body can be changed.
52. The retrieval device of claim 51, where the proximal end of the proximal capturing portion is permeable.
53. The retrieval device of claim 51, where the proximal end of the proximal capturing portion is non-permeable.
54. The retrieval device of claim 51, further comprising a first plurality of flanges located on the proximal open end of the distal capturing portion and a second plurality of flanges located on the distal open end of the proximal capturing portion, where the first and second plurality of flanges can removably engage each other.
55. The retrieval device of claim 51, where the proximal capturing portion and retrieval body are rotatable relative to each other.
56. The retrieval device of claim 51, where the proximal end of the proximal capturing portion is connected about the leading wire such that the leading wire is moveable therethrough.
57. The retrieval device of claim 51, further comprising a sheath extending over the leading wire, where the proximal end of the proximal capturing portion is affixed to the sheath.

58. The retrieval device of claim 51, where the proximal capturing portion comprises a structure selected from a group consisting of a laser cut tube, an etched tube, an injection molded structure.
59. The retrieval device of claim 58, where the at least one leading wire is attached to the proximal capturing portion via a joint or junction
60. The retrieval device of claim 51, where the proximal capturing portion has a coverage density that increases from the open distal end to the proximal end.
61. The retrieval device of claim 51, where the proximal capturing portion is formed from a wire comprising super-elastic outer shell and an inner core of a radiopaque material.
62. The retrieval device of claim 61, where the inner core comprises a material selected from a group consisting of platinum, iridium, gold, and tantalum or combination thereof.
63. The retrieval device of claim 51, where the proximal capturing portion is jointless.
64. The retrieval device of claim 51, where at least a portion of a surface of the proximal capturing portion comprises a structure selected from the group consisting of a basket, a filter, a bag, a coil, a helical wire structure, a mesh, a single wound wire, a plurality of crossing wires, and a combination thereof.
65. A method of removing an obstruction from a blood vessel, the method comprising:
advancing a catheter distal to the obstruction;
deploying a first capturing portion distal of the obstruction, where the first capturing portion comprises a translating surface and a capturing surface, the translating surface having an open proximal end and the capturing surface having a permeable distal end, and at least one leading wire affixed to the capturing surface and extending through the capturing portion and through the catheter, where the translating surface and capturing surface are configured so that a translating surface axial strength is greater than that of a capturing surface axial strength;

proximally moving the leading wire to compress the capturing surface without compressing the translating surface sufficient to cause axial deformation of the translating surface such that the translating surface gradually advances over the obstruction; and

removing the obstruction and first capturing portion from the blood vessel.

66. The method of claim 65, where pulling on the leading wire causes the capturing surface to apply a spring force against the translating surface such that the open proximal end advances along the obstruction.

67. The method of claim 65, where applying a threshold force on the leading wire while the open proximal end engages the obstruction causes the capturing surface to invert within the capturing portion.

68. The method of claim 67, where applying the threshold force comprises continuing to apply the threshold force to withdraw the capturing surface into the catheter distal end.

69. The method of claim 67, where applying the threshold force comprises continuing to apply the threshold force to invert the capturing portion such that the capturing surface is proximal to the translating surface.

70. The method of claim 65, where pulling on the leading wire to apply the force to the capturing surface comprises applying the force to the permeable distal end.

71. The method of claim 65, where pulling on the leading wire to apply the force to the capturing surface comprises applying the force to the capture surface.

72. The method of claim 65, further comprising a second capturing portion having an open distal end and a proximal end attached axially moveable relative to the first capturing portion, such that moving the first capturing portion over the obstruction causes the open proximal end of the first capturing portion to move towards the open distal end of the second capturing portion to surround the obstruction.

73. The method of claim 72, where the proximal end of the second capturing portion is non-permeable and temporarily occludes or interrupts flow.
74. The method of claim 72, where the proximal end of the second capturing portion is permeable and permits flow during removal of the obstruction.
75. The method of claim 72, further comprising continuing to move the first capturing portion towards the second capturing portion such that the open proximal end and the open distal end can removably engage each other.
76. The method of claim 72, further comprising compressing the second capturing portion about the obstruction to further secure the obstruction.
77. A reentry device for withdrawing an object into a distal end of a sheath, the reentry device comprising:
a elongate member having a distal portion and a lumen extending therethrough; and
a plurality of first tines arranged circumferentially at the distal portion, the plurality of first tines each having a distal end forming a first discontinuous funnel where the distal end of each first tine is spaced from the distal end of an adjacent first tine, wherein the first discontinuous funnel is collapsible upon withdrawal into the distal end of the sheath..
78. The reentry device of claim 77, further comprising:
a second funnel spaced proximal to the first funnel, where the second funnel is collapsible upon withdrawal into the distal end of the sheath; and
wherein a distal perimeter of the first discontinuous funnel shape is distal to a distal perimeter of the second funnel.
79. The reentry device of claim 78, where the second funnel comprises a plurality of second tines arranged circumferentially at the distal portion, the plurality of second tines each having a distal end forming a second discontinuous funnel shape where the distal end of each second tine is spaced from the distal end of an adjacent second tine.

80. The reentry device of claim 79, further comprising at least one protrusion on an inner surface of at least the first or second tine.
81. The reentry device of claim 78, where the second funnel comprises a continuous funnel.
82. The reentry device of claim 77, further comprising a second funnel, where the second funnel comprises a flexible layer.
83. The reentry device of claim 82, where the flexible layer comprises a mesh braid.
84. The reentry device of claim 83, where the mesh braid comprises a Nitinol braid.
85. The reentry device of claim 77, where the second funnel comprises a tapered split tube.
86. A reentry device for withdrawing an object into a distal end of a sheath, the reentry device comprising:
an elongate member having a distal portion and a lumen extending therethrough, the elongate member sized to slidably fit within the sheath;
a first slotted funnel comprising a plurality of first tines each having free ends discontinuous with free ends of adjacent first tines, where the first slotted funnel is collapsible upon withdrawal into the distal end of the sheath; and
a second funnel located proximal to the free ends of the first tines.
87. The reentry device of claim 86, where the second funnel comprises a second slotted funnel comprising a plurality of second tines each having free ends discontinuous with free ends of adjacent second tines, where the first slotted funnel is collapsible upon withdrawal into the distal end of the sheath.
88. The reentry device of claim 87, where the free ends of the second tines are located proximally to the free ends of the first tines relative to the elongate member and where the first and second tines are rotationally offset.

89. The reentry device of claim 86, where the second funnel comprises a second continuous funnel, where the second continuous funnel is collapsible upon withdrawal into the distal end of the sheath.

90. The reentry device of claim 86, where the second funnel comprises a tapered split tube.

91. The reentry device of claim 86, where the second funnel comprises a flexible layer.

92. The reentry device of claim 91 where the flexible layer comprises a mesh braid.

93. The reentry device of claim 92, where the mesh braid comprises a Nitinol braid.

94. A retrieval system for withdrawing an object into a distal end of a sheath, the retrieval system comprising:

an elongate member having a distal portion and a lumen extending therethrough; a flexible layer having a portion affixed to the elongate member, where a first end of the flexible layer is configured to form a funnel at the distal portion of the elongate member;

a retrieval device advanceable through the elongate member for engaging the object, where proximal movement of the retrieval device into the flexible causes the flexible layer to engage the retrieval device to assist the retrieval device securing the object to the sheath.

95. The retrieval system of claim 94, where the elongate member comprises a first shaft and a second shaft, where the first and shaft are in telescoping engagement, where a first end of the flexible layer is affixed to the first shaft and a second end of the flexible member is affixed to the second shaft, where moving the first and second shaft to decrease a distance between ends of the flexible member causes the flexible material to form a funnel when the flexible layer further inverts about the second elongate shaft.

96. The retrieval system of claim 94, where the flexible layer is affixed to the elongate member at a single location.
97. The retrieval system of claim 96, where the flexible member is affixed to the elongate member at a distal location, and where the flexible member has a pre-determined funnel shape such that when unrestrained the flexible member forms the funnel shape about the distal end of the elongate member.
98. The retrieval system of claim 96, where the flexible member is affixed to the elongate member at a proximal location, and where the flexible member extends beyond the distal end of the elongate member.
99. The retrieval system of claim 98, where proximal movement of the retrieval device engages the flexible member causing the flexible member to form a funnel shape.
100. The retrieval system of claim 98, where the flexible member has a pre-determined funnel shape such that the flexible member assumes a funnel shape when un-restrained.
101. The retrieval system of claim 94, where the flexible layer comprises a mesh braid.
102. The retrieval system of claim 101, where the mesh braid comprises a Nitinol braid.
103. The retrieval system of claim 94, where the flexible layer comprises a flexible layer of material.
104. The retrieval system of claim 94, further comprising:
a retrieval sheath extending through the second elongate member having a proximal capture portion affixed to a distal end;
at least one leading wire extending through the retrieval sheath, where a distal section of the leading wire comprises a distal stiffness and where a proximal section of the leading wire comprises a proximal stiffness, where the proximal stiffness is greater than the distal stiffness; and

a distal capturing portion at the distal end of the leading wire, the distal capturing portion being axially moveable relative to the proximal capture portion.

105. The retrieval system of claim 104, where the distal section of the leading wire extends proximally for a pre-determined distance from the distal capturing portion to allow navigation of a distal section of the leading wire within the cerebral vasculature.

106. The retrieval system of claim 105, where the pre-determined distance is at least 20 cm.

107. A system for removing a object within a body, the system device comprising:

a sheath having a sheath distal end and a sheath lumen extending therethrough; a reentry device slidably located in the sheath lumen and being advanceable out of the sheath distal end, the reentry device comprising an elongate member having a first slotted funnel and a second slotted funnel, the elongate member having a distal portion and a lumen extending therethrough and being sized to slidably fit within the sheath,

the first slotted funnel and the second slotted funnel each respectively comprising a plurality of first and second tines, each of the tines having a free end discontinuous with the free ends of an adjacent tines, where a distal end of the second slotted funnel is proximal to a distal end of the first slotted funnel and where the first and second tines are rotationally offset such that upon withdrawal into the sheath, the second tines cover a portion off a space between adjacent first tines.

108. The system of claim 107, further comprising a capturing section slidably advanceable through the elongate member.

109. A retrieval system for use with a catheter, the system comprising:
a retrieval sheath;
a proximal capture portion affixed to a distal end of the retrieval sheath;
at least one leading wire extending through the retrieval sheath, where a distal section of the leading wire comprises a distal stiffness and where a proximal section of the leading wire comprises a proximal stiffness, where the proximal stiffness is greater than the distal stiffness; and

a distal capturing portion at the distal end of the leading wire, the distal capturing portion being axially moveable relative to the proximal capture portion.

110. The retrieval system of claim 109, an insertion tool slidably located over the retrieval sheath, the insertion tool comprising a gripping region affixed to a rigid section, where compression of the gripping portion creates a frictional fit between the insertion tool such that when the insertion tool is coupled to the retrieval sheath, compression of the gripping portion and axial movement of the insertion tool advances the retrieval sheath within the catheter.

111. The retrieval system of claim 109, where distal section of the leading wire is joined to the proximal section of the leading wire at a bond region, where the bond region is located a pre-determined distance from distal capture portion to allow navigation of a distal section of the system within the cerebral vasculature.

112. The retrieval system of claim 111, where the pre-determined distance is at least 20 cm.

113. The retrieval system of claim 109, further comprising a funnel slidably located on the sheath, where movement of the proximal capture portion and distal capture portion within the funnel causes the proximal and distal capture portions to compress.

114. The retrieval system of claim 109, where the insertion tool comprises a loading tube such that the proximal capture portion and distal capture portion can compress within the loading tube.

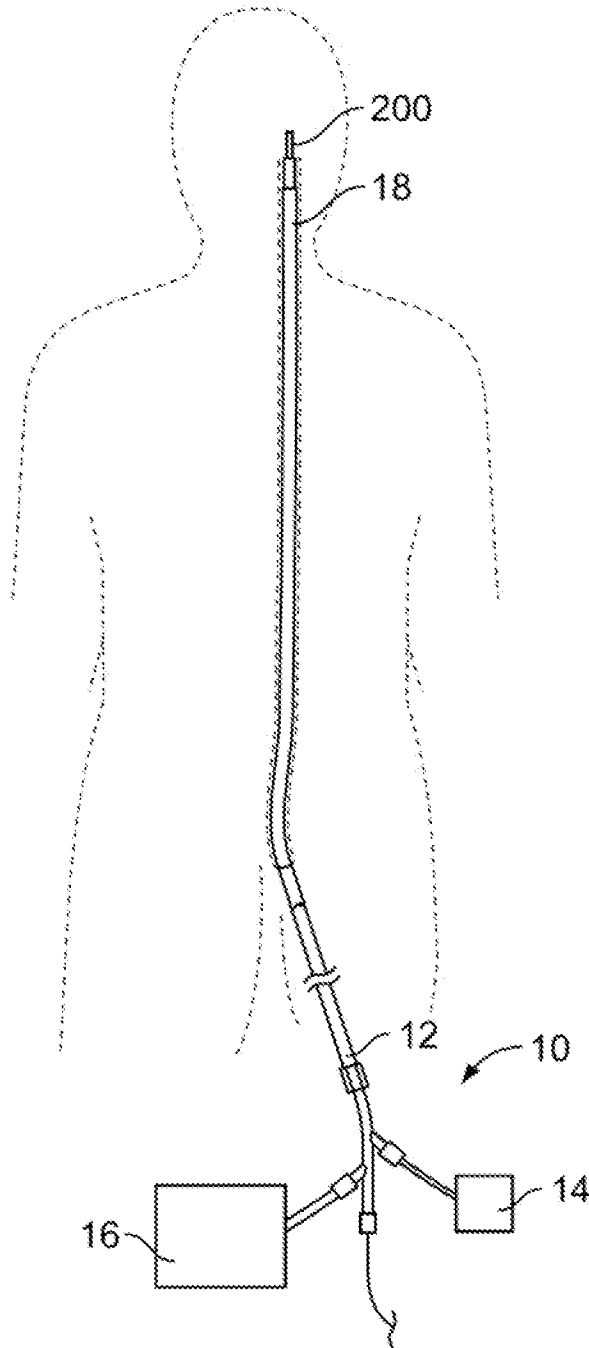

FIG. 1A

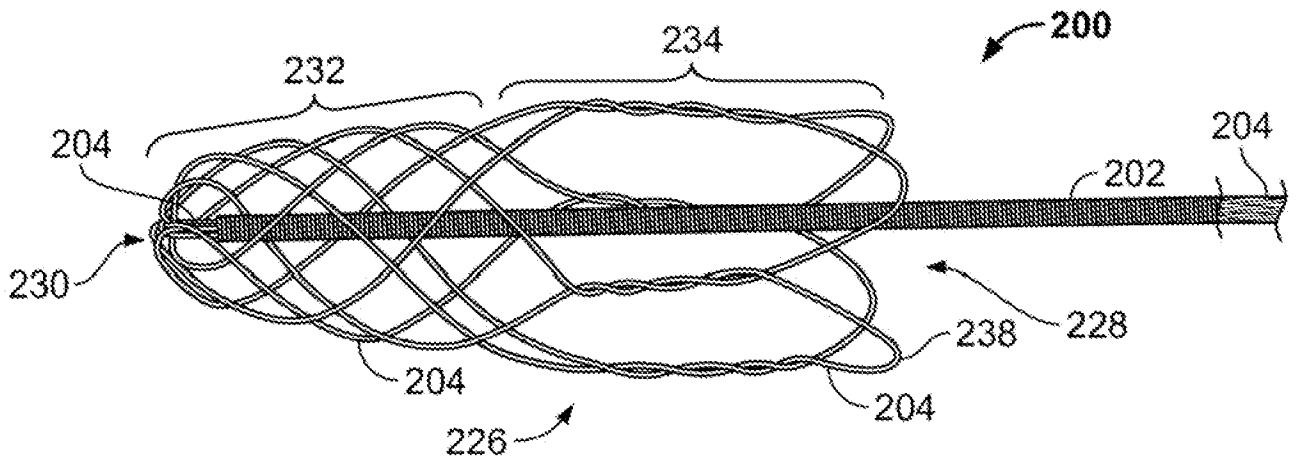

FIG. 1B

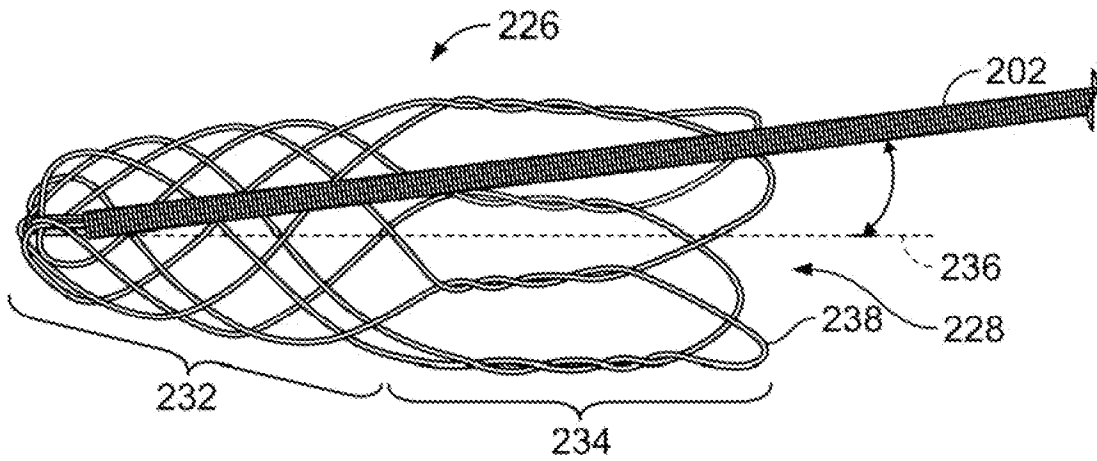

FIG. 1C

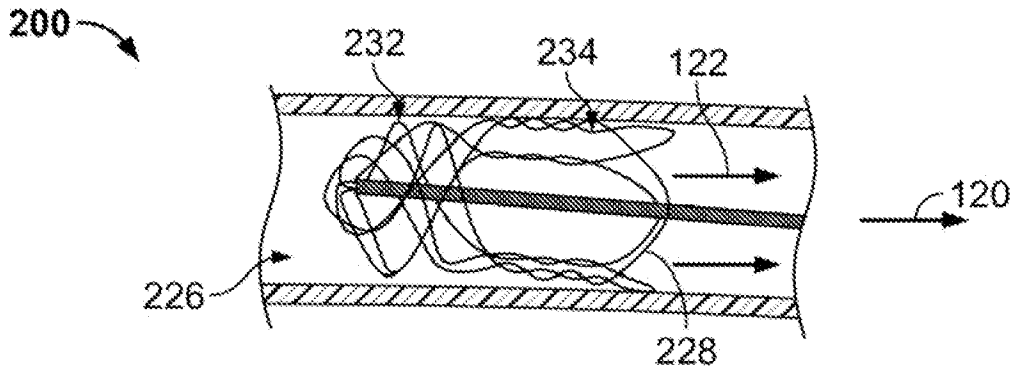

FIG. 2A

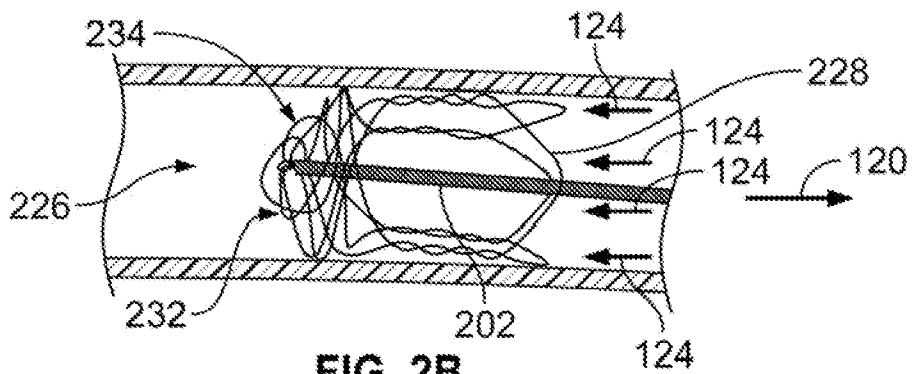

FIG. 2B

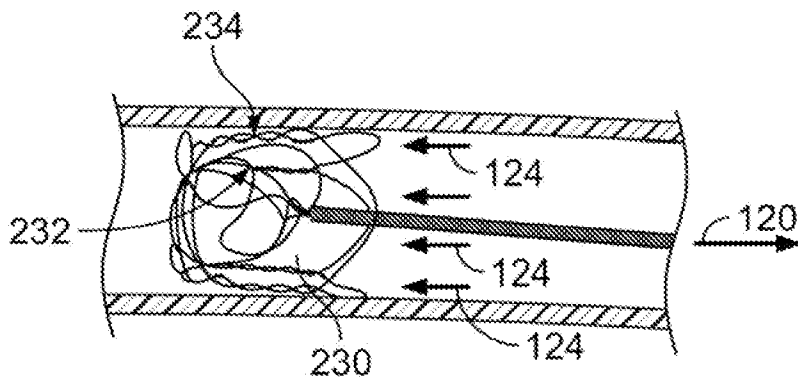

FIG. 2C

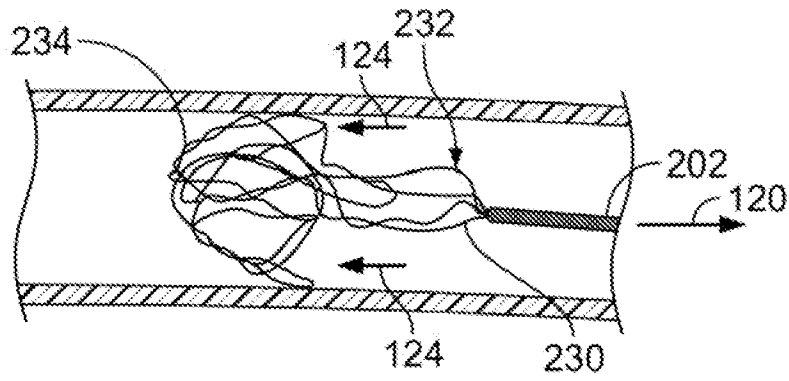

FIG. 2D

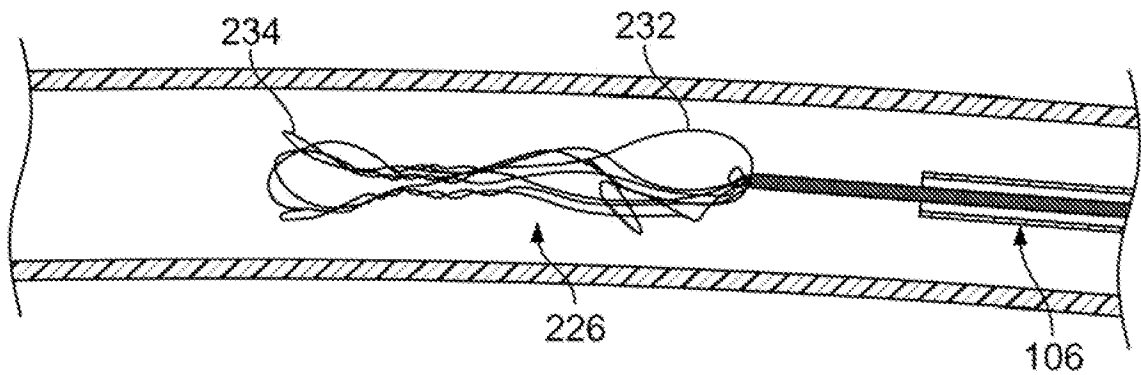

FIG. 2E

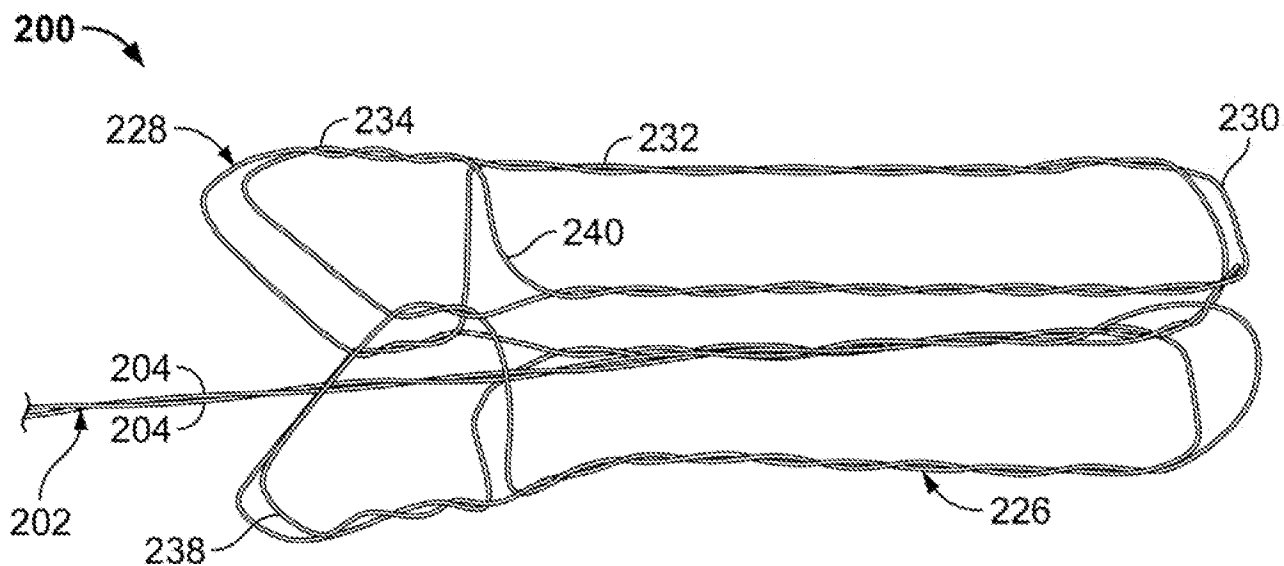

FIG. 3A

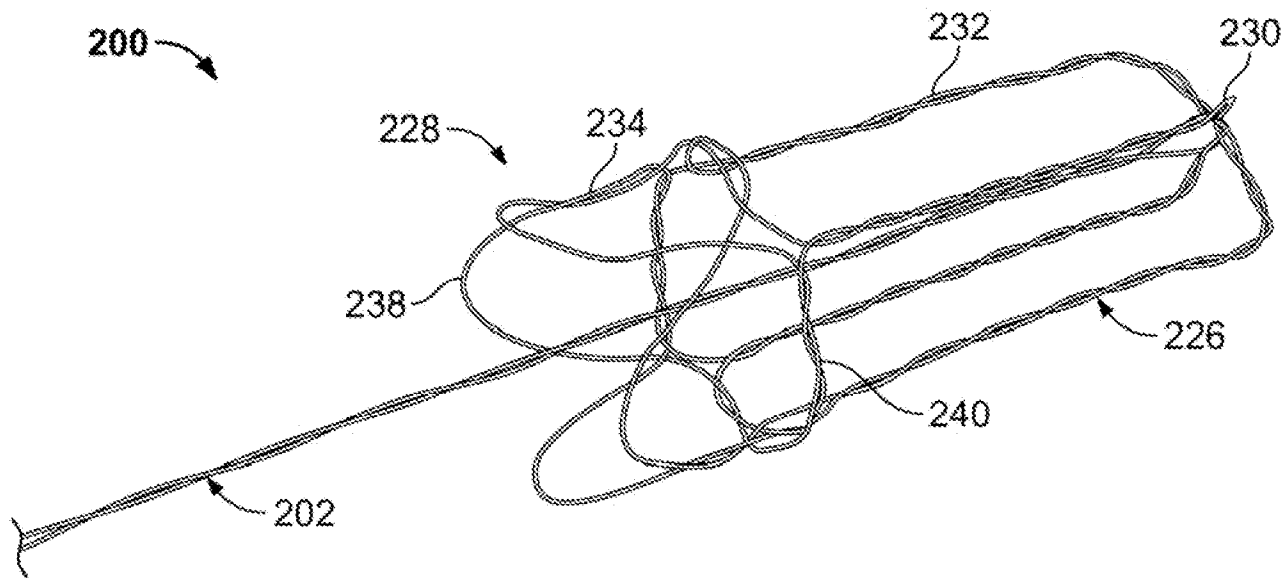

FIG. 3B

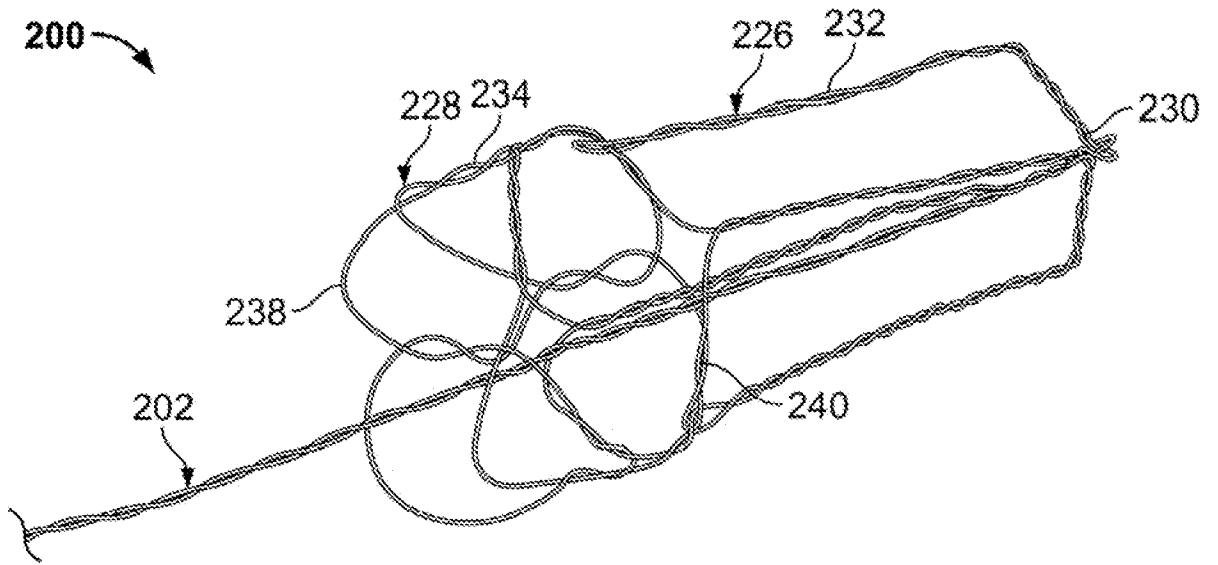

FIG. 3C

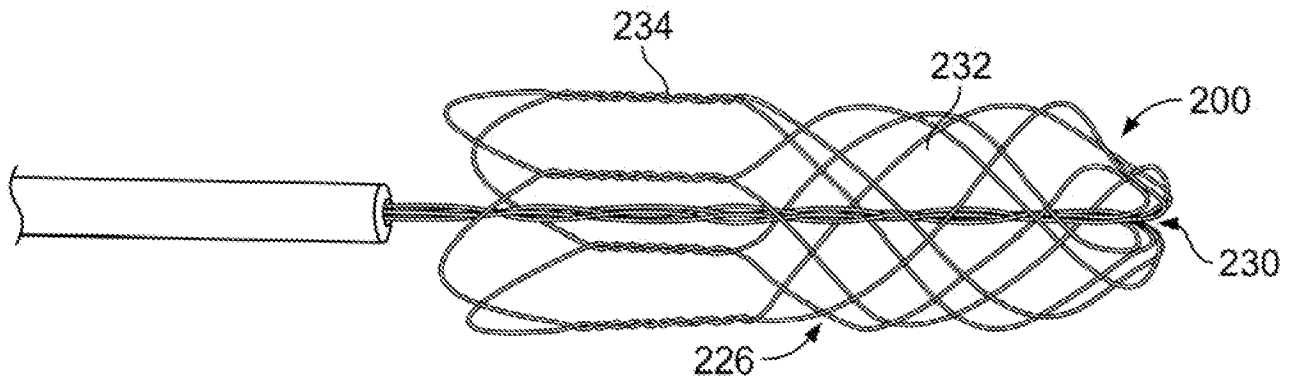

FIG. 3D

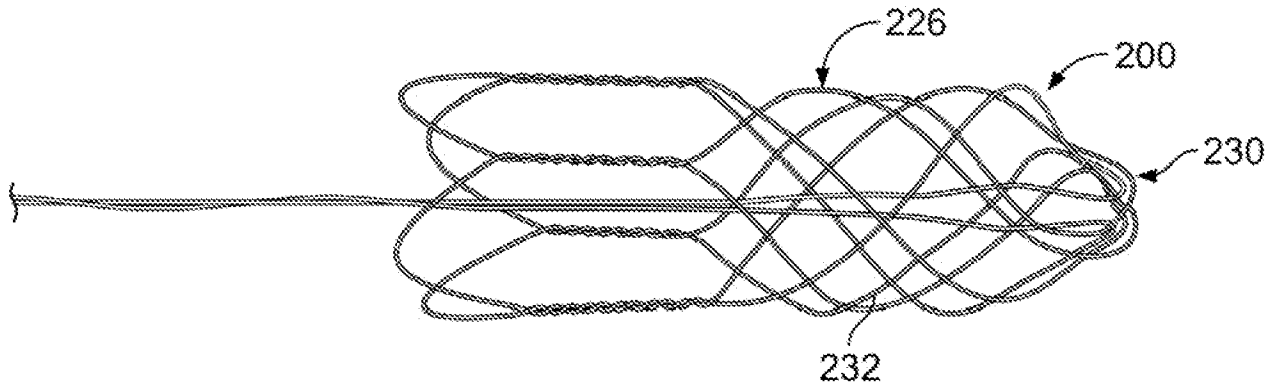

FIG. 3E

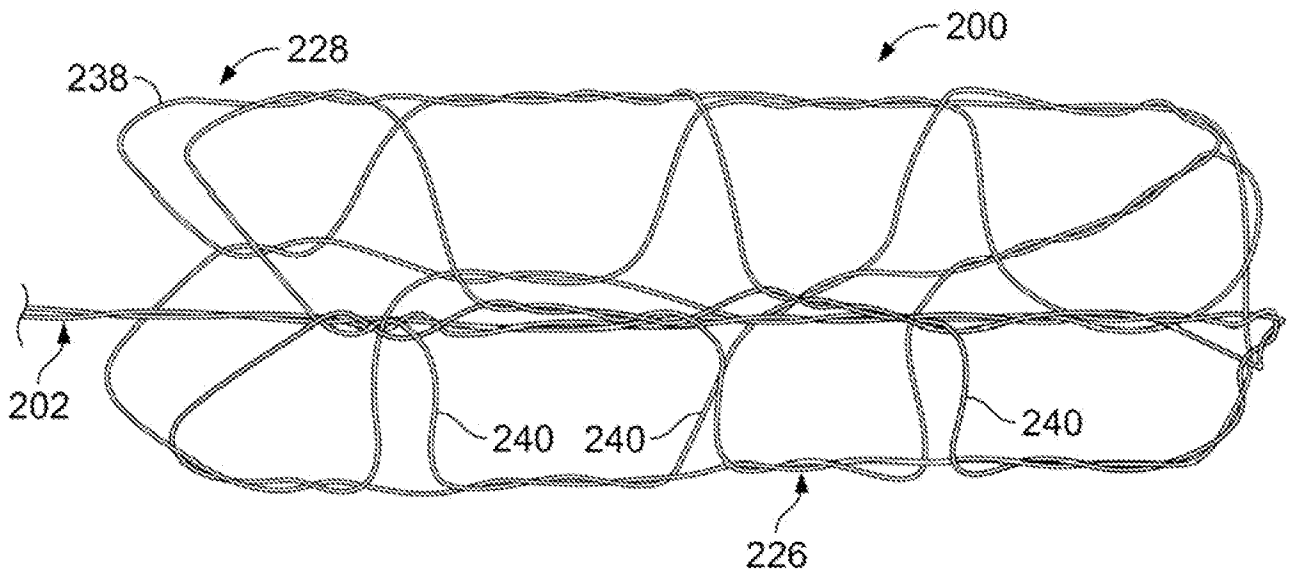

FIG. 3F

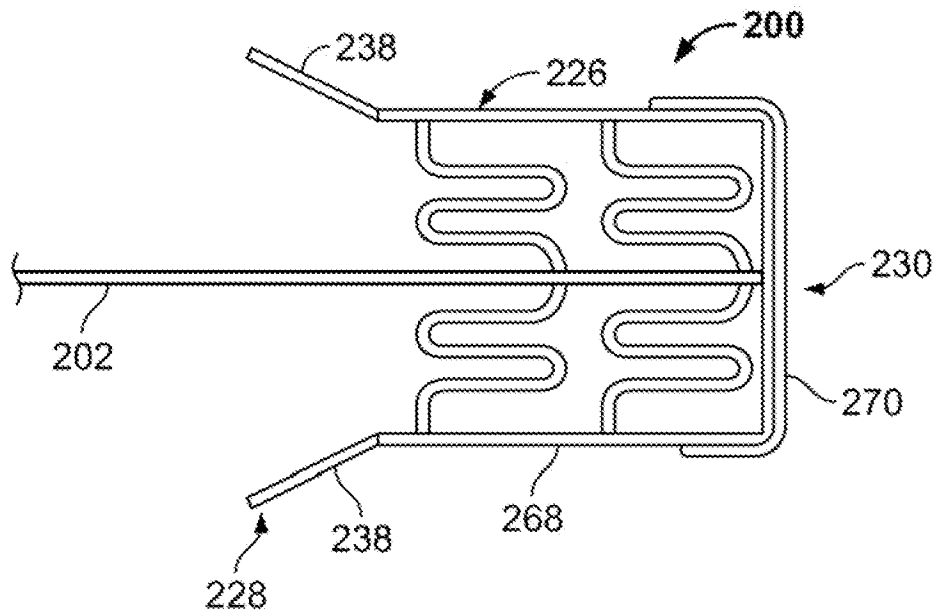

FIG. 3G

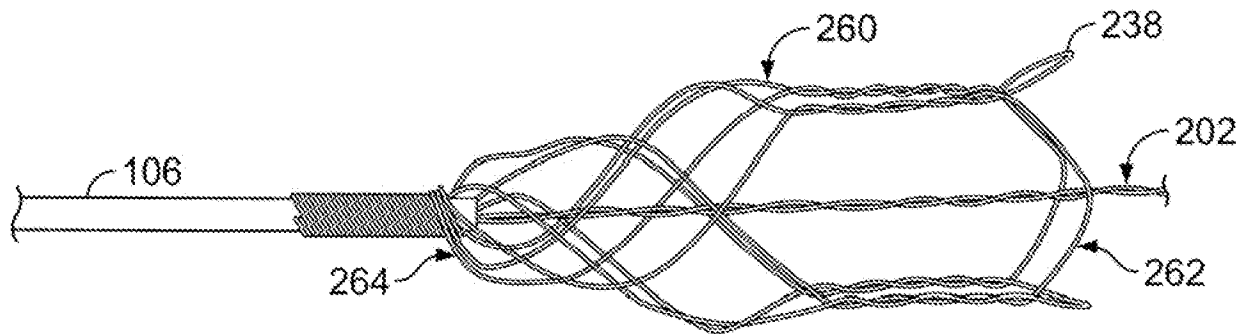

FIG. 3H

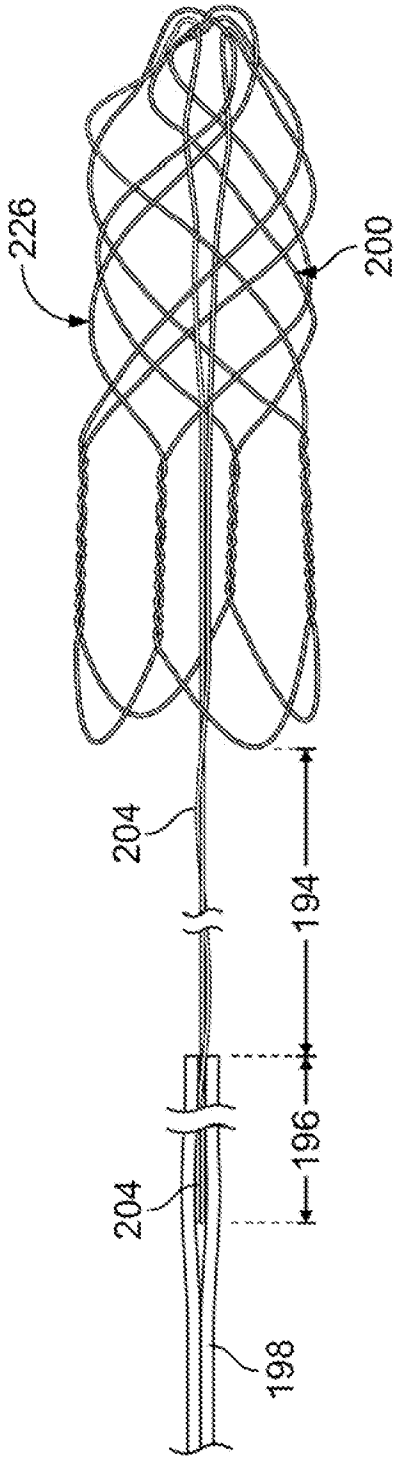

FIG. 4A

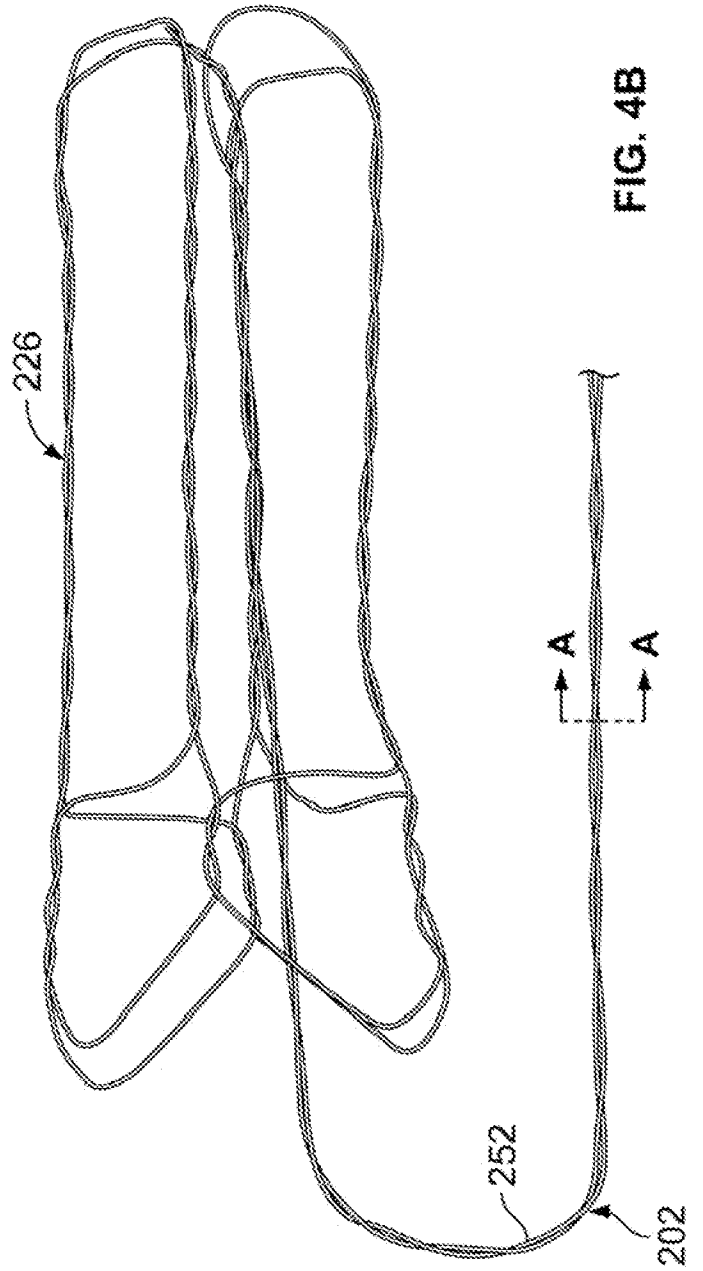

FIG. 4B

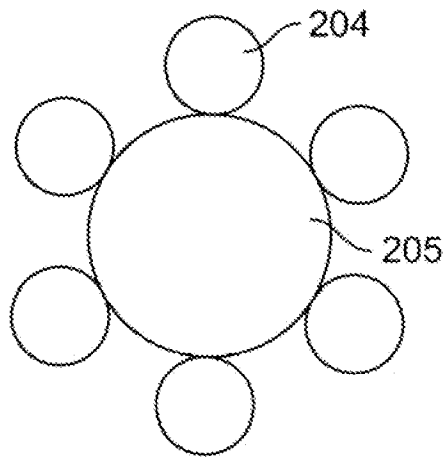

FIG. 4C

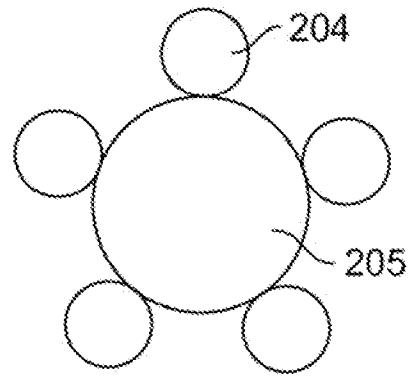

FIG. 4D

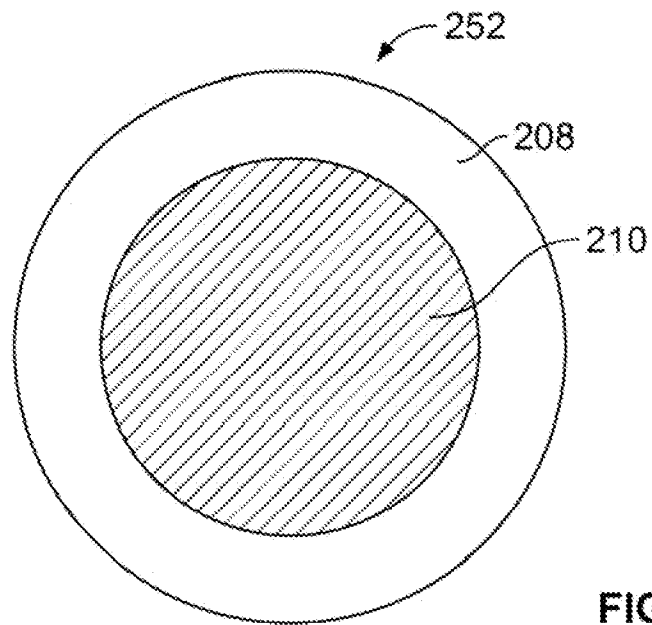

FIG. 4E

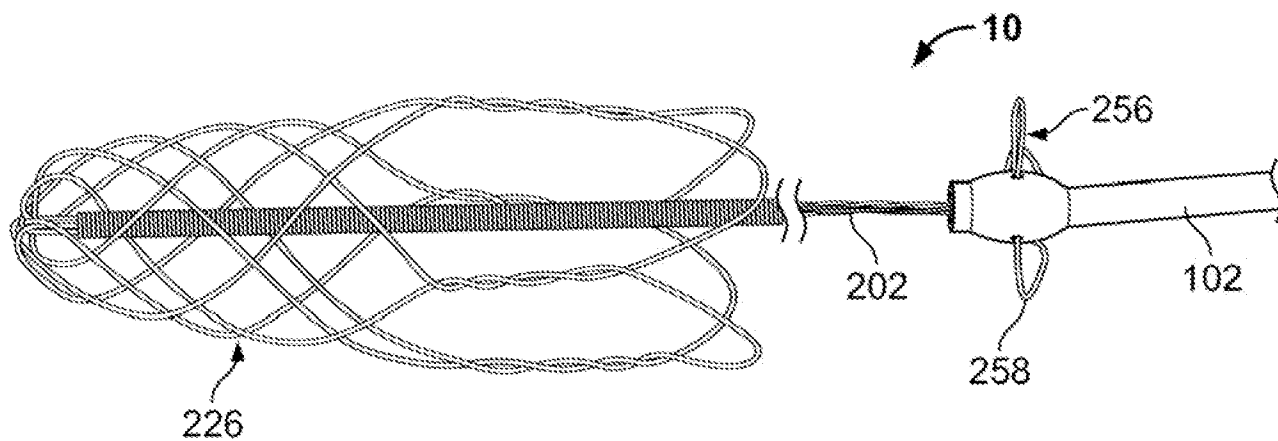

FIG. 5A

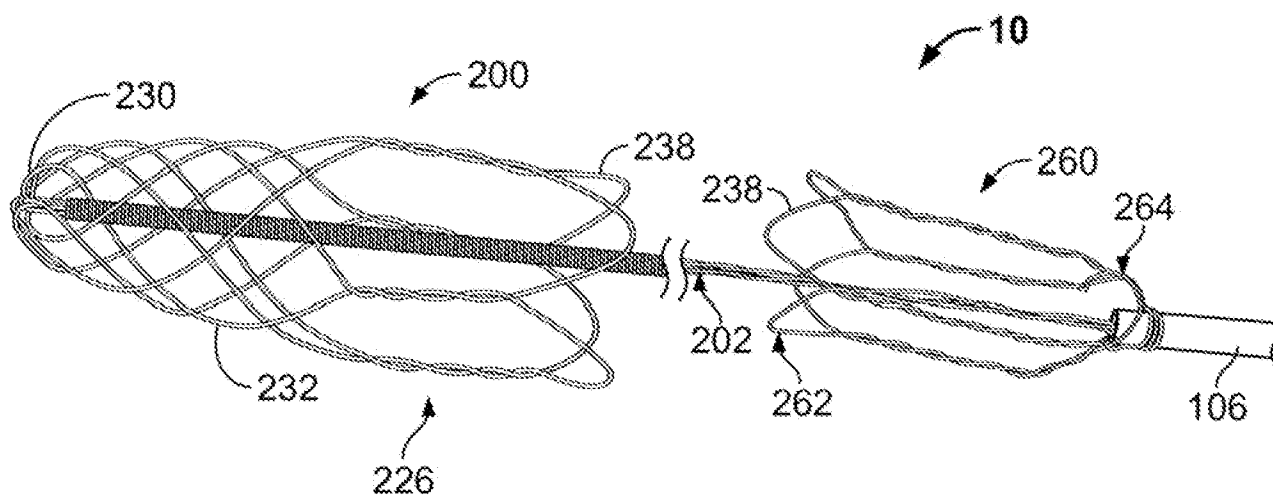

FIG. 5B

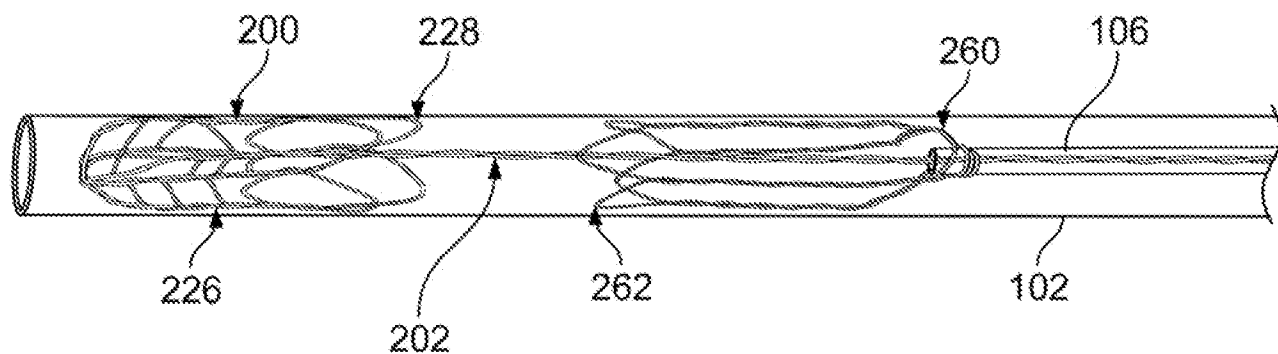

FIG. 5C

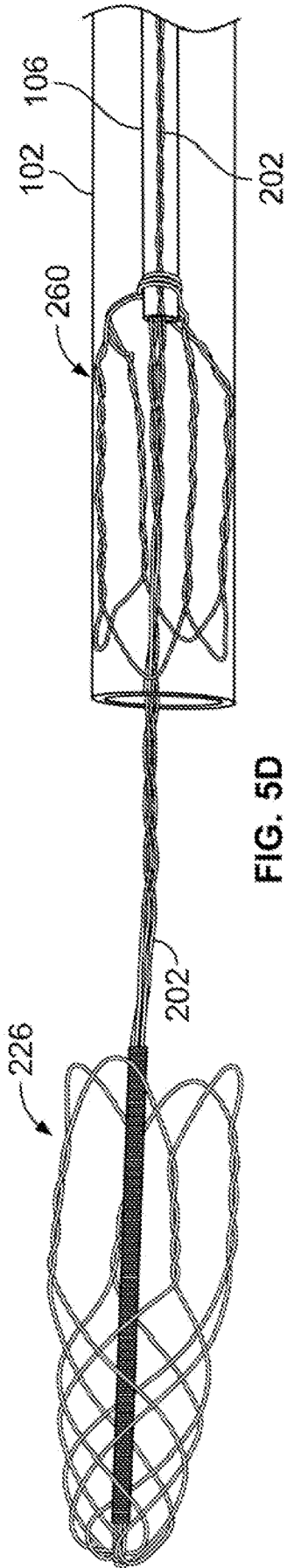

FIG. 5D

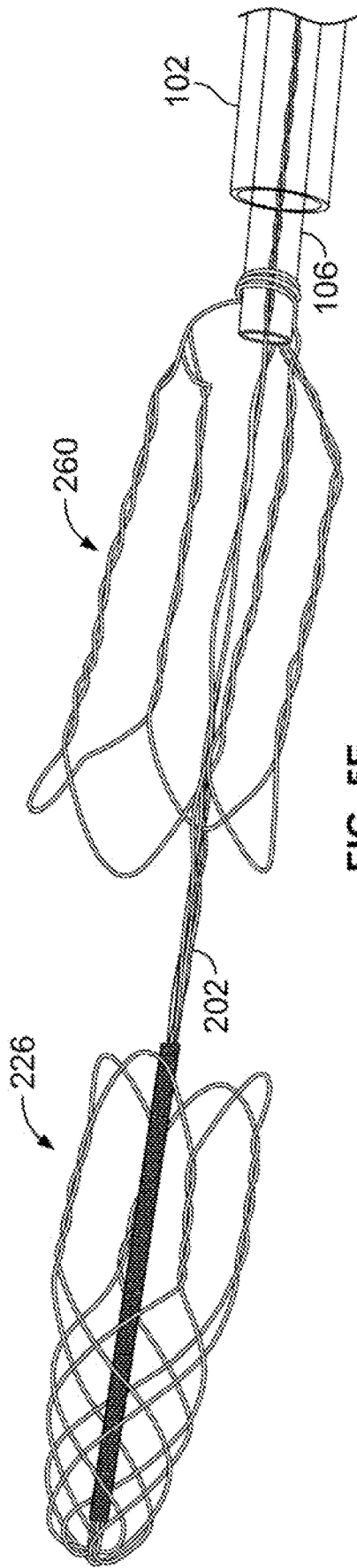

FIG. 5E

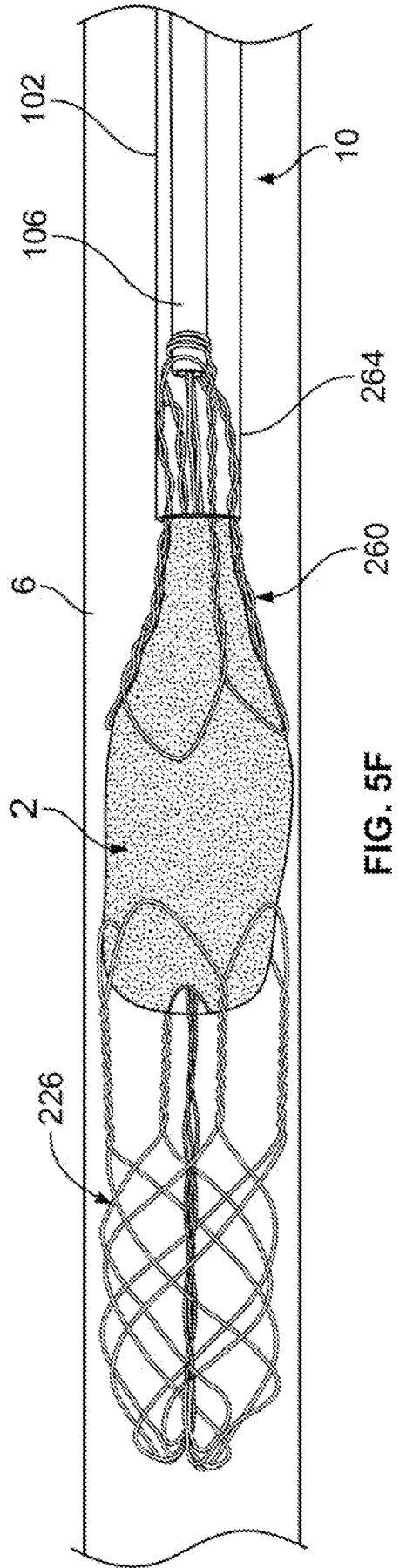

FIG. 5F

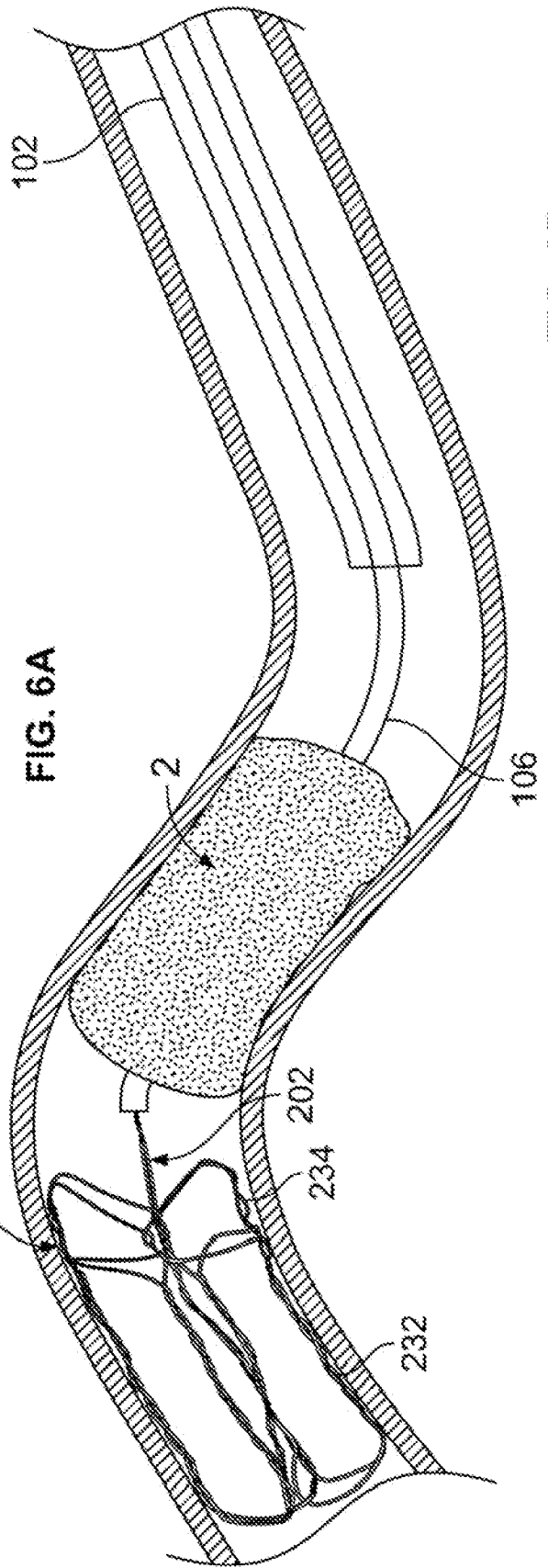
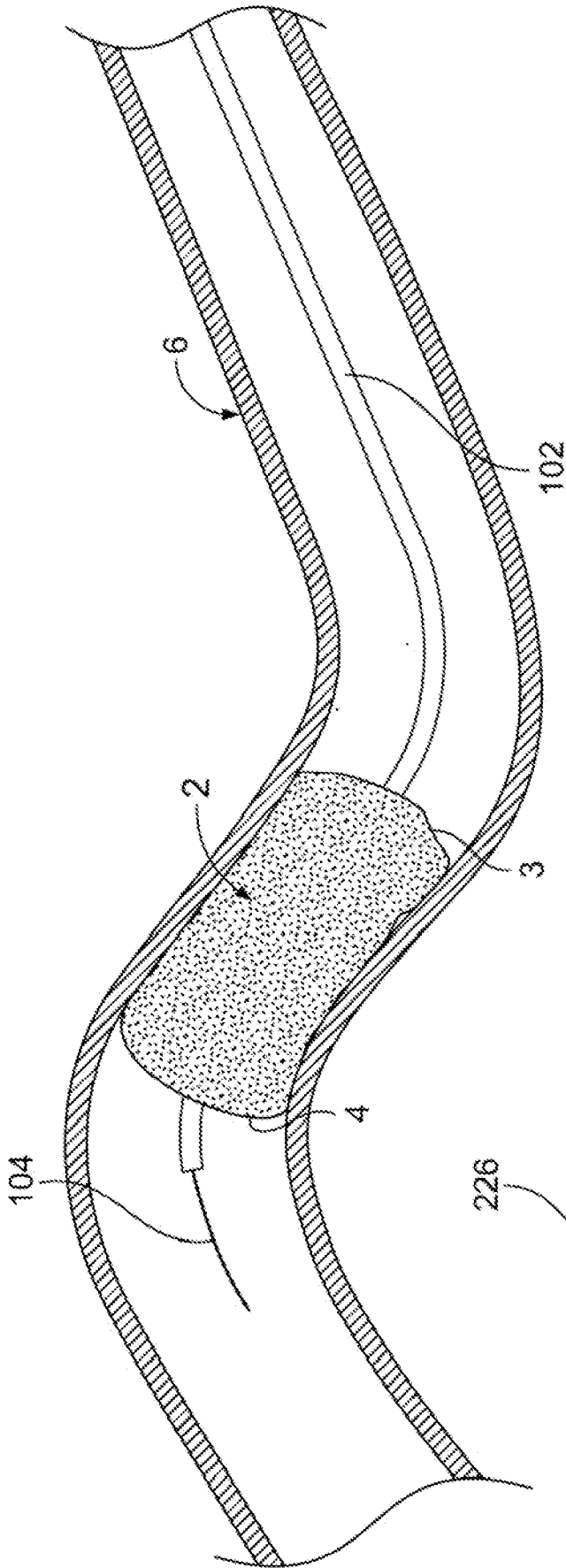

FIG. 6B

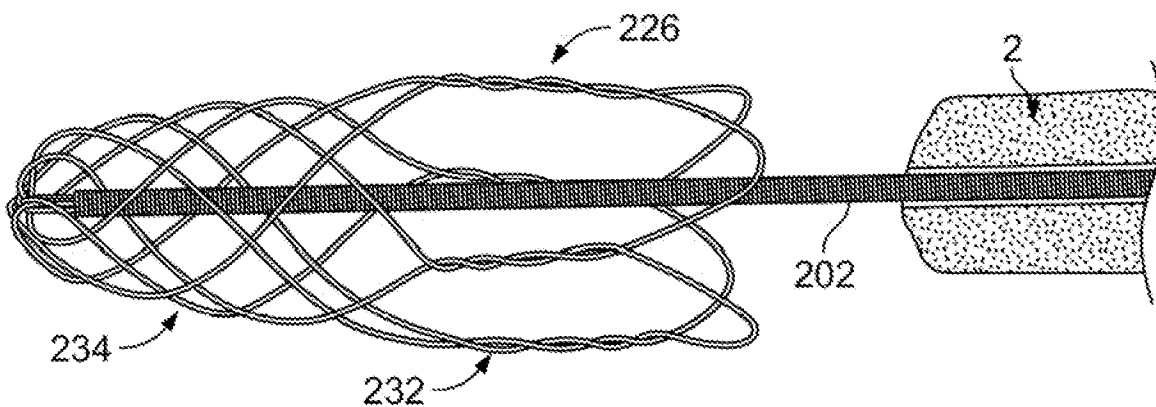

FIG. 7A

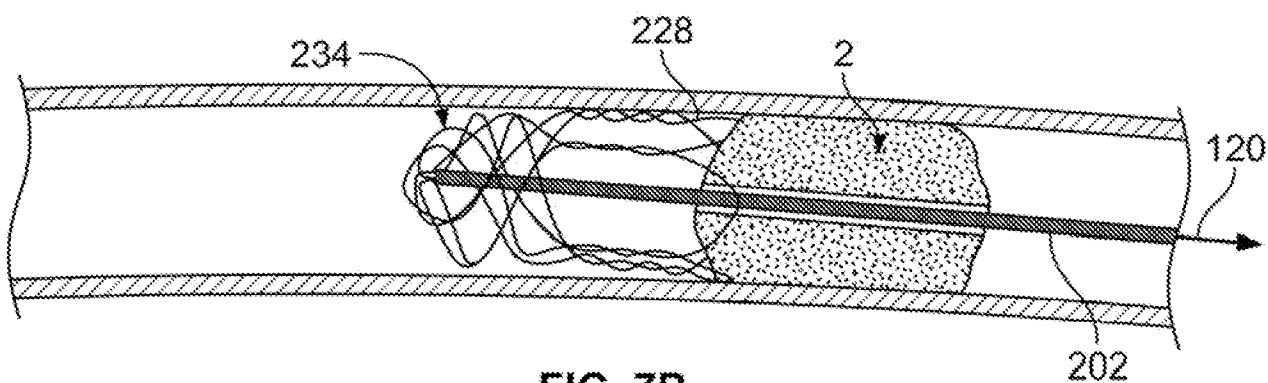

FIG. 7B

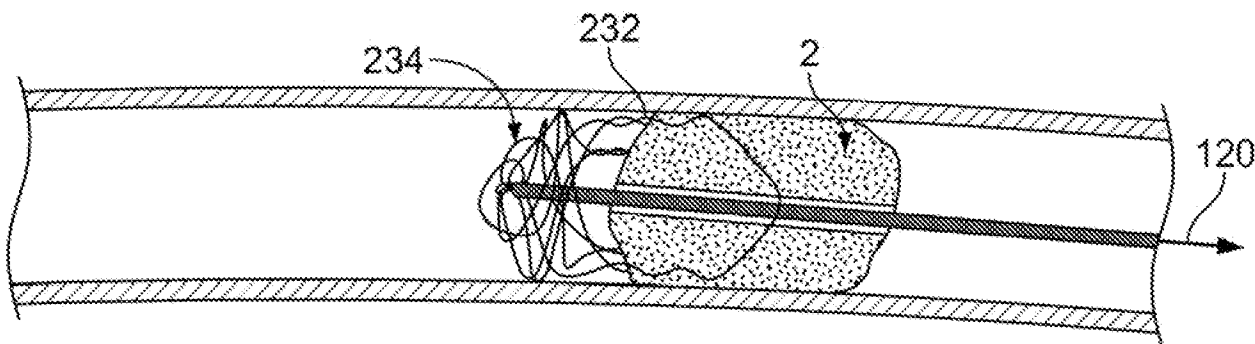

FIG. 7C

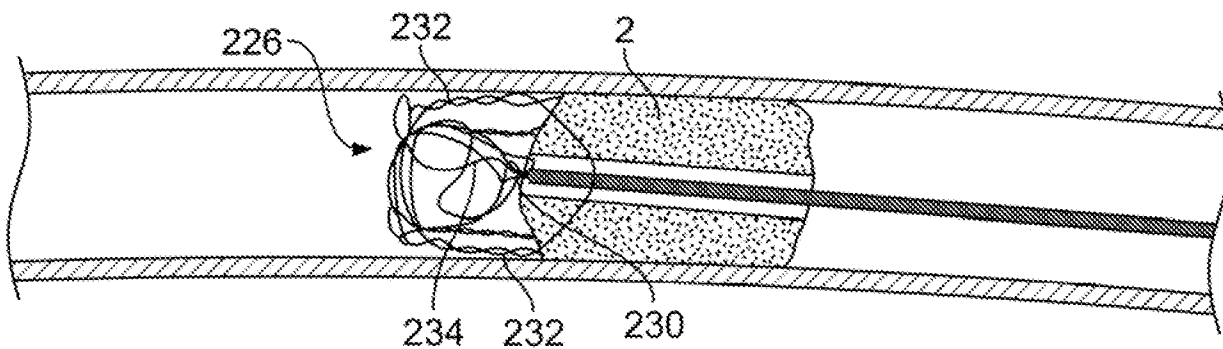

FIG. 7D

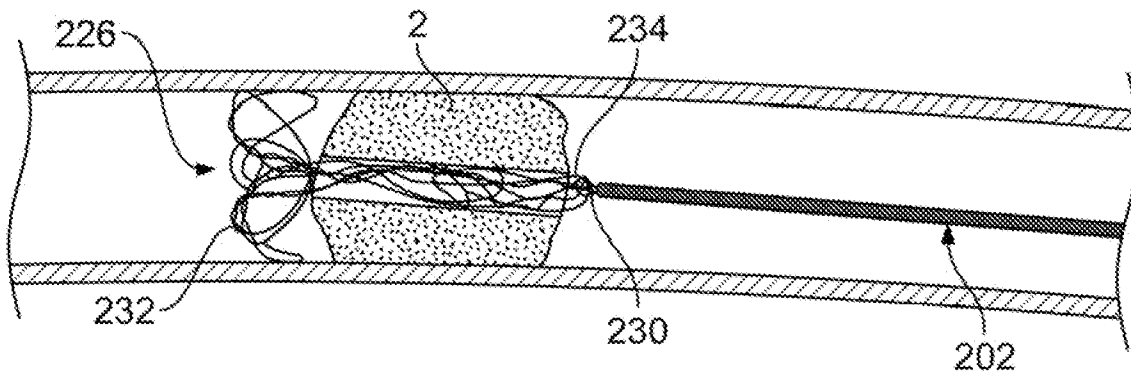

FIG. 7E

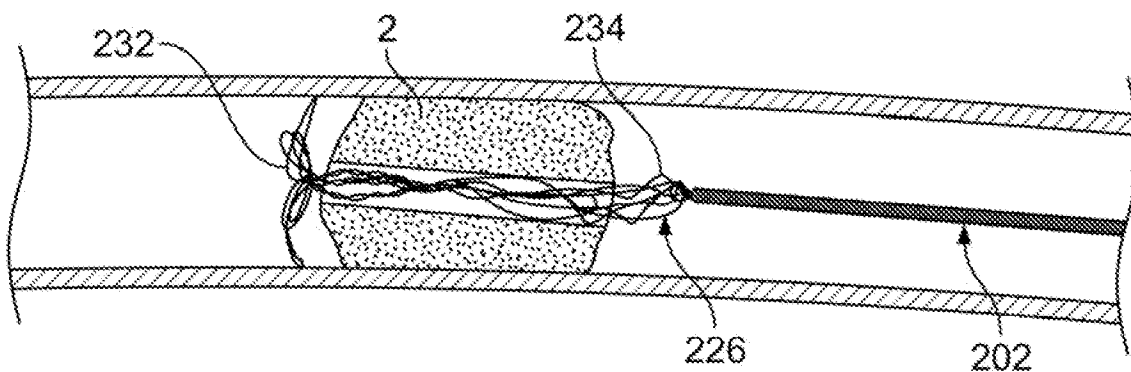

FIG. 7F

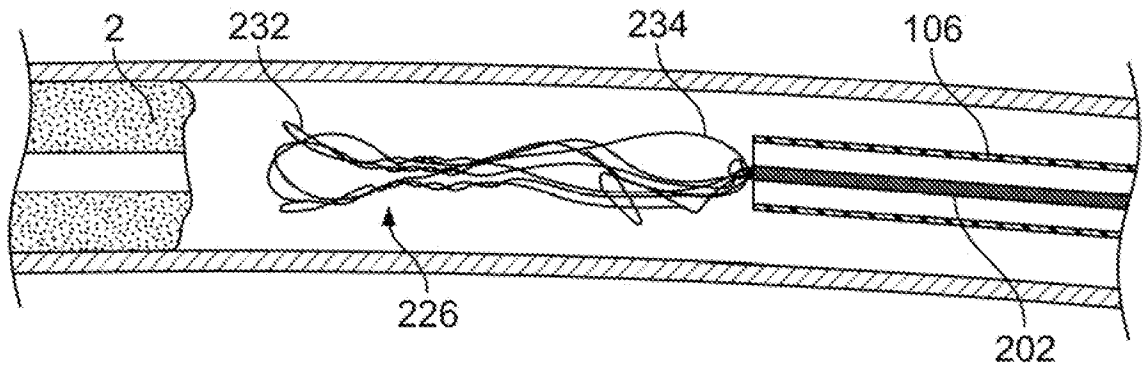

FIG. 7G

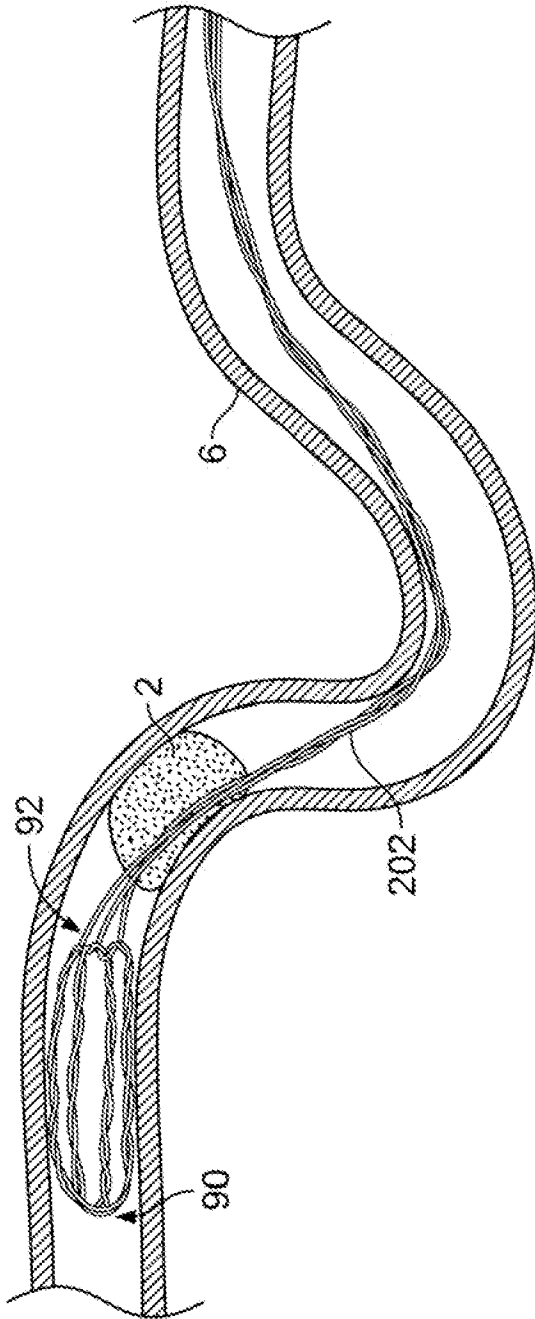

FIG. 8A

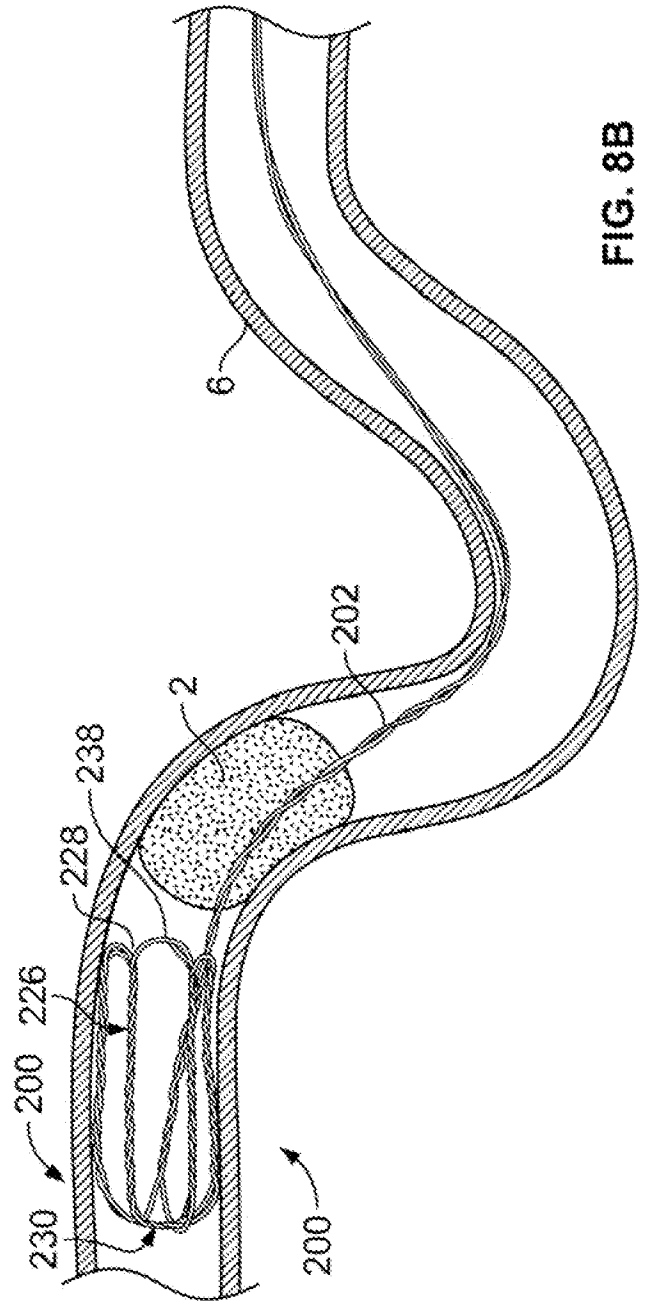

FIG. 8B

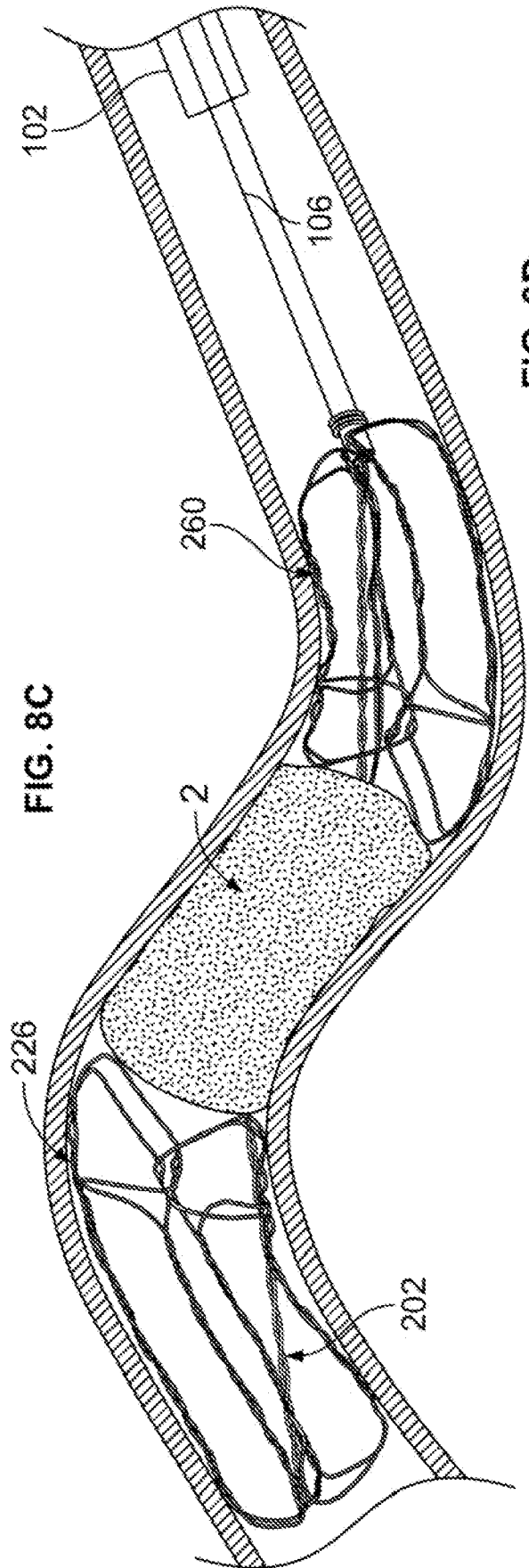
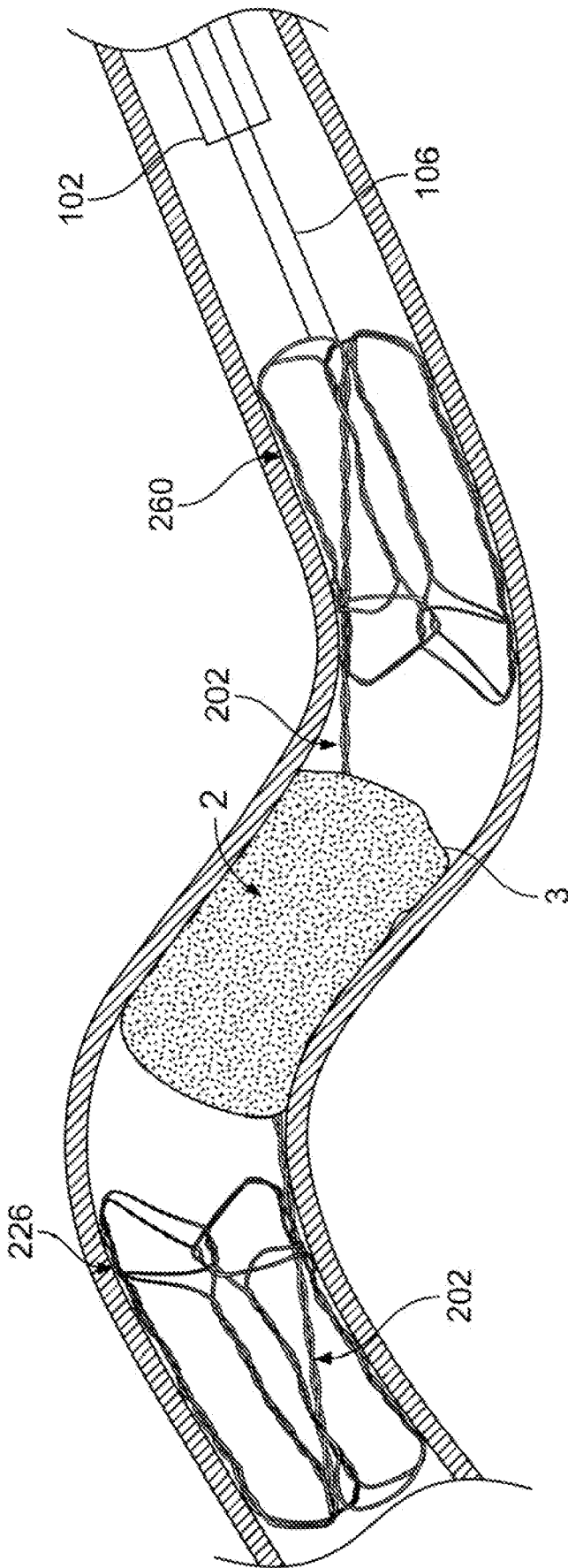

FIG. 8D

FIG. 8C

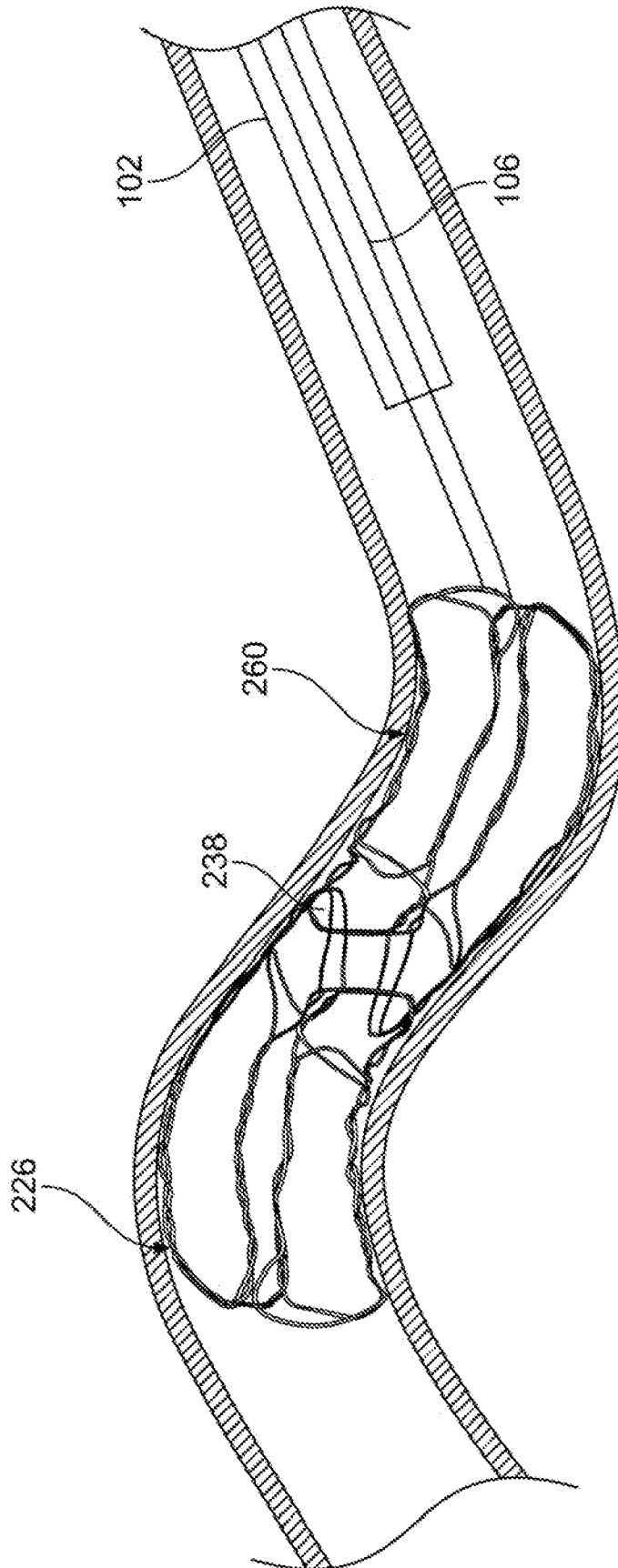

FIG. 8E

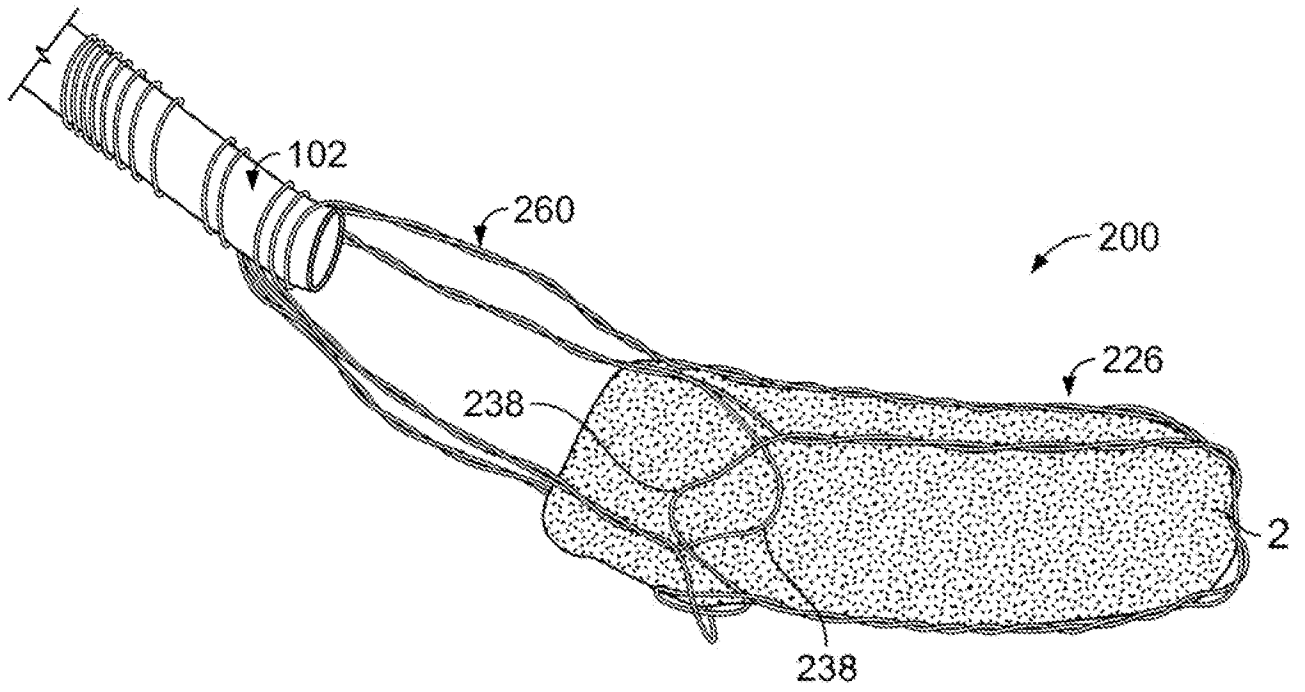

FIG. 8F

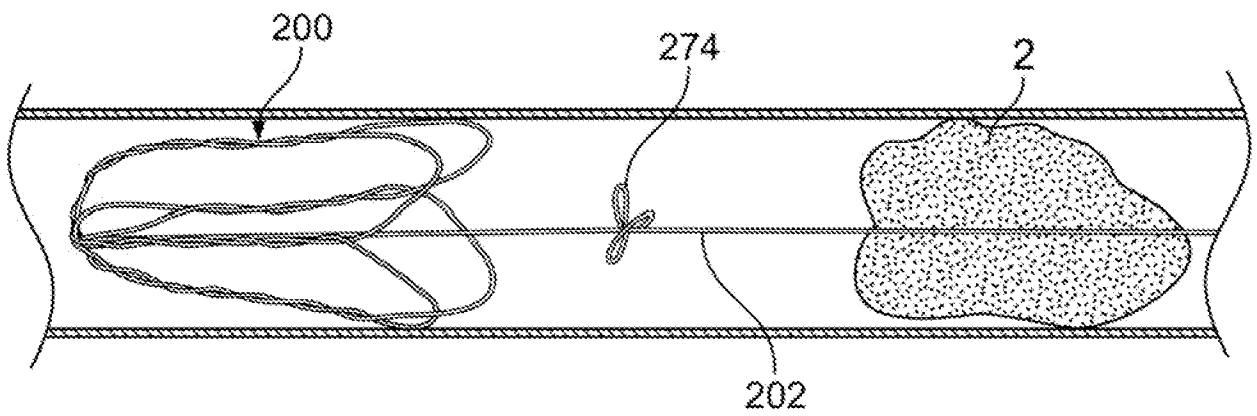

FIG. 9

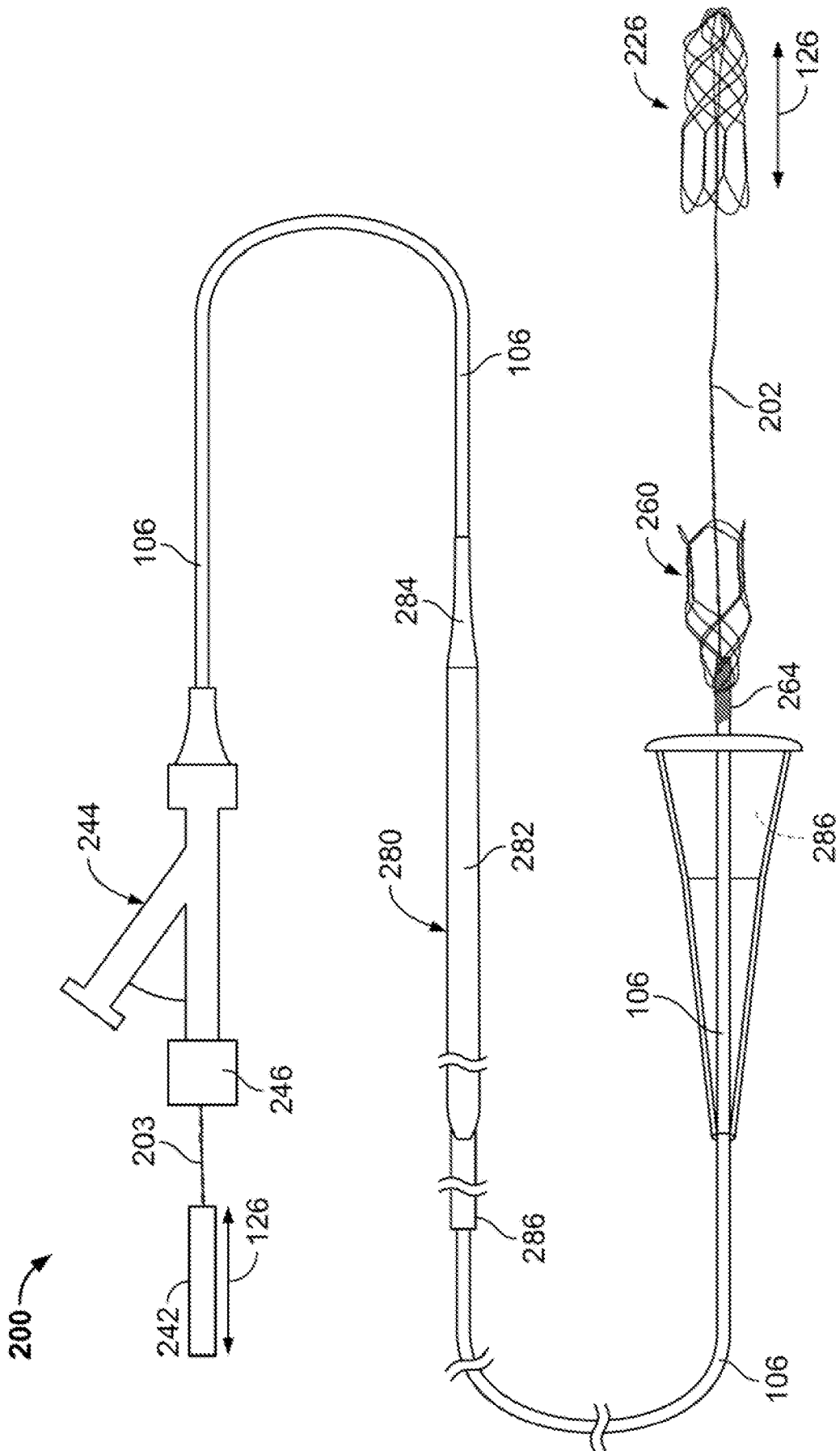

FIG. 10

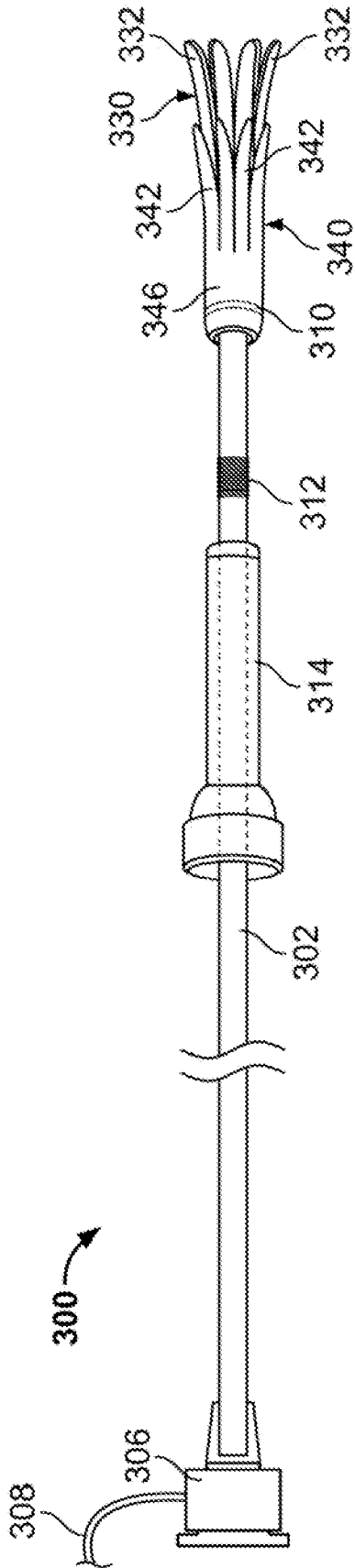

FIG. 11A

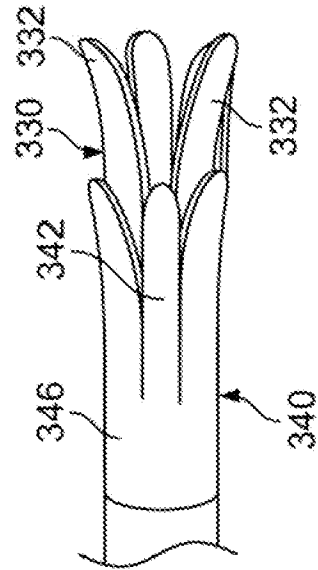

FIG. 11B

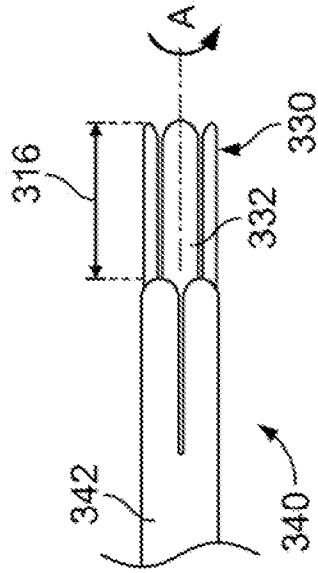

FIG. 11C

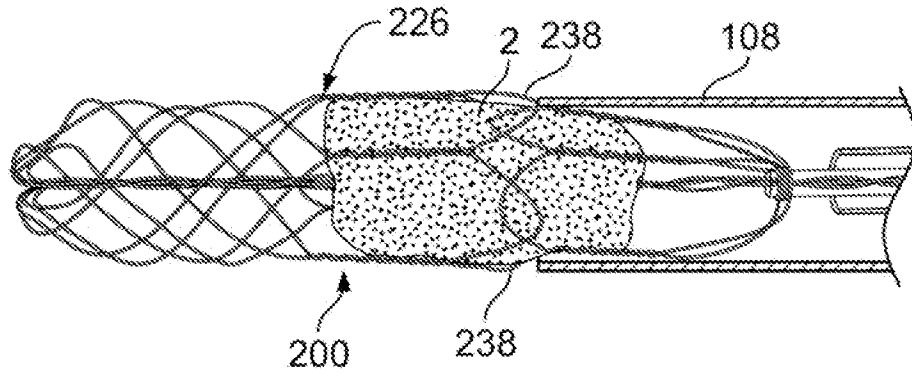

FIG. 12A

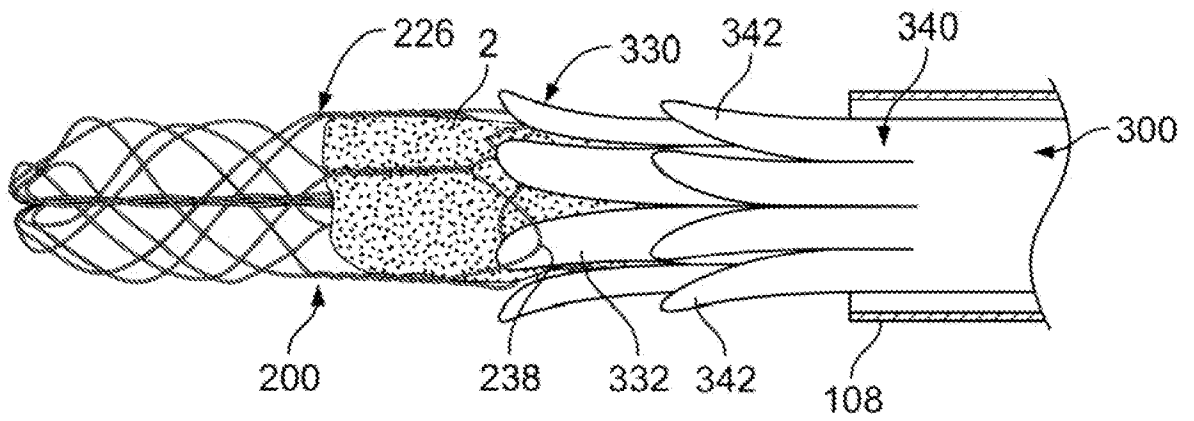

FIG. 12B

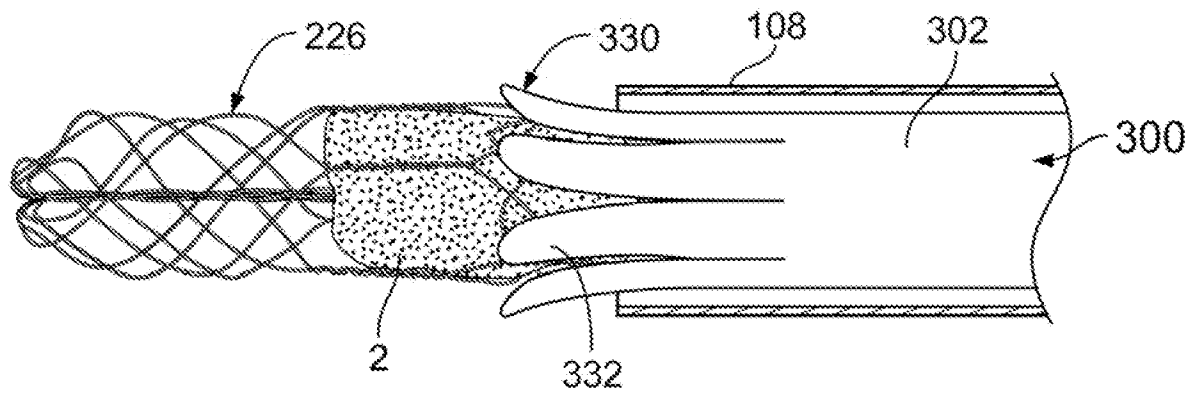

FIG. 12C

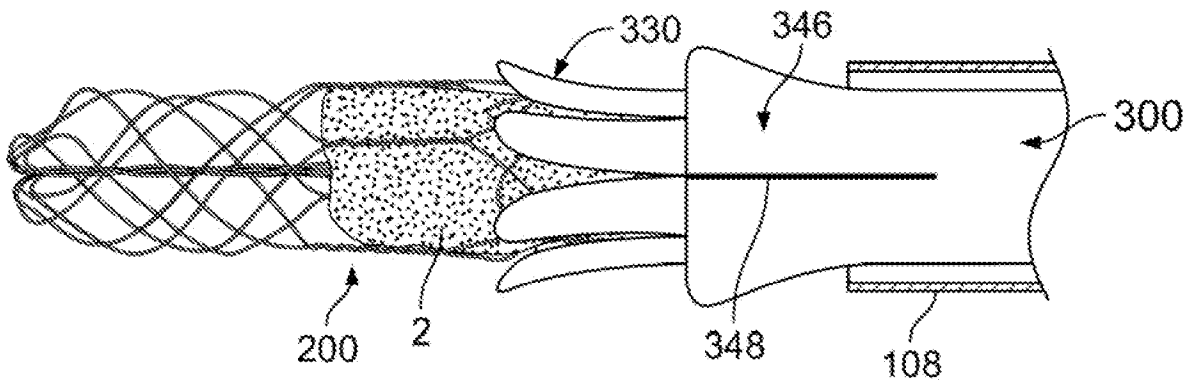

FIG. 12D

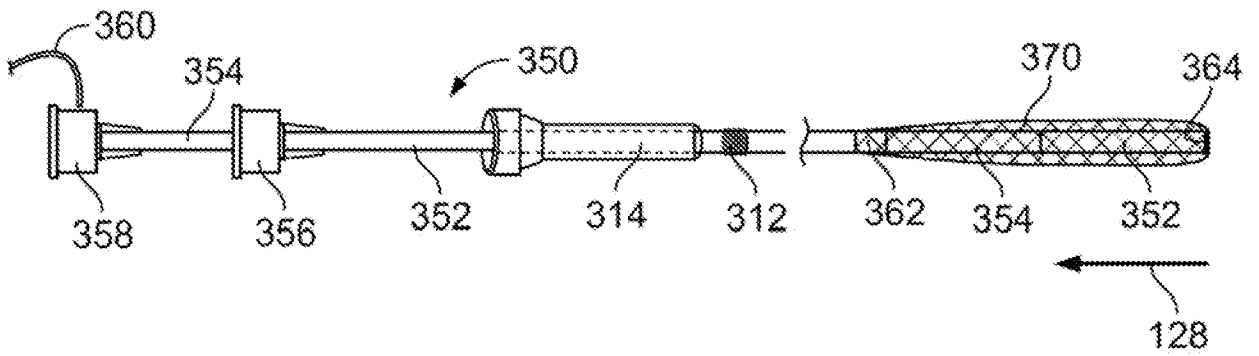

FIG. 13A

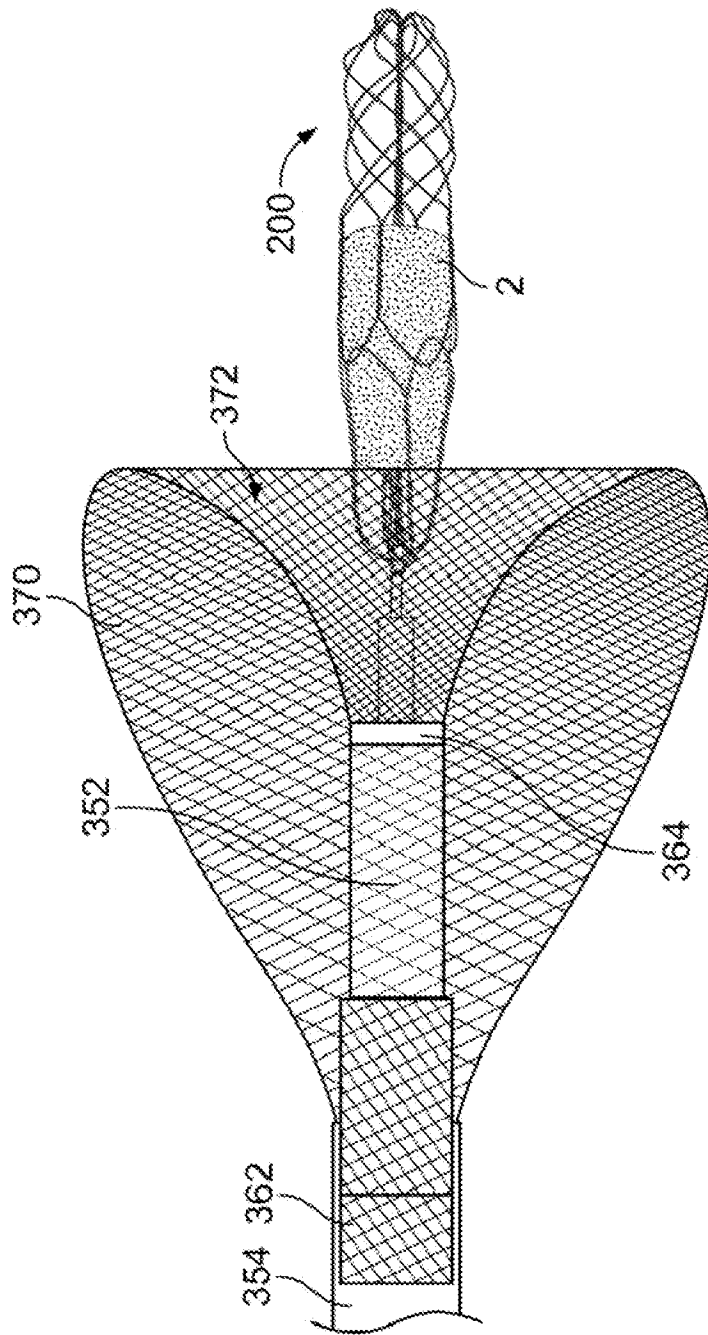

FIG. 13B

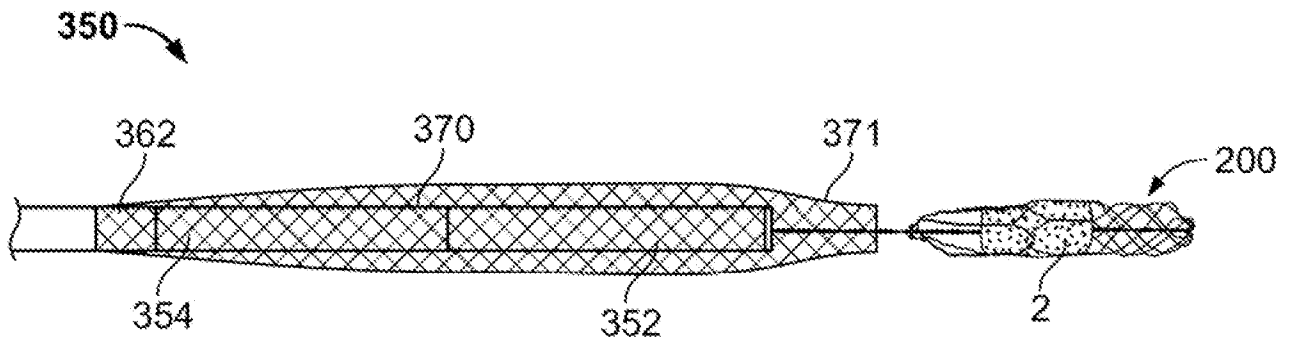

FIG. 13C

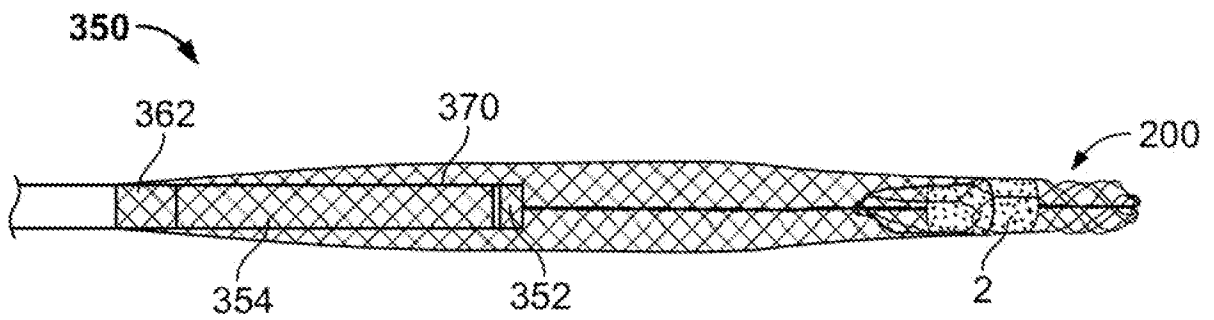

FIG. 13D

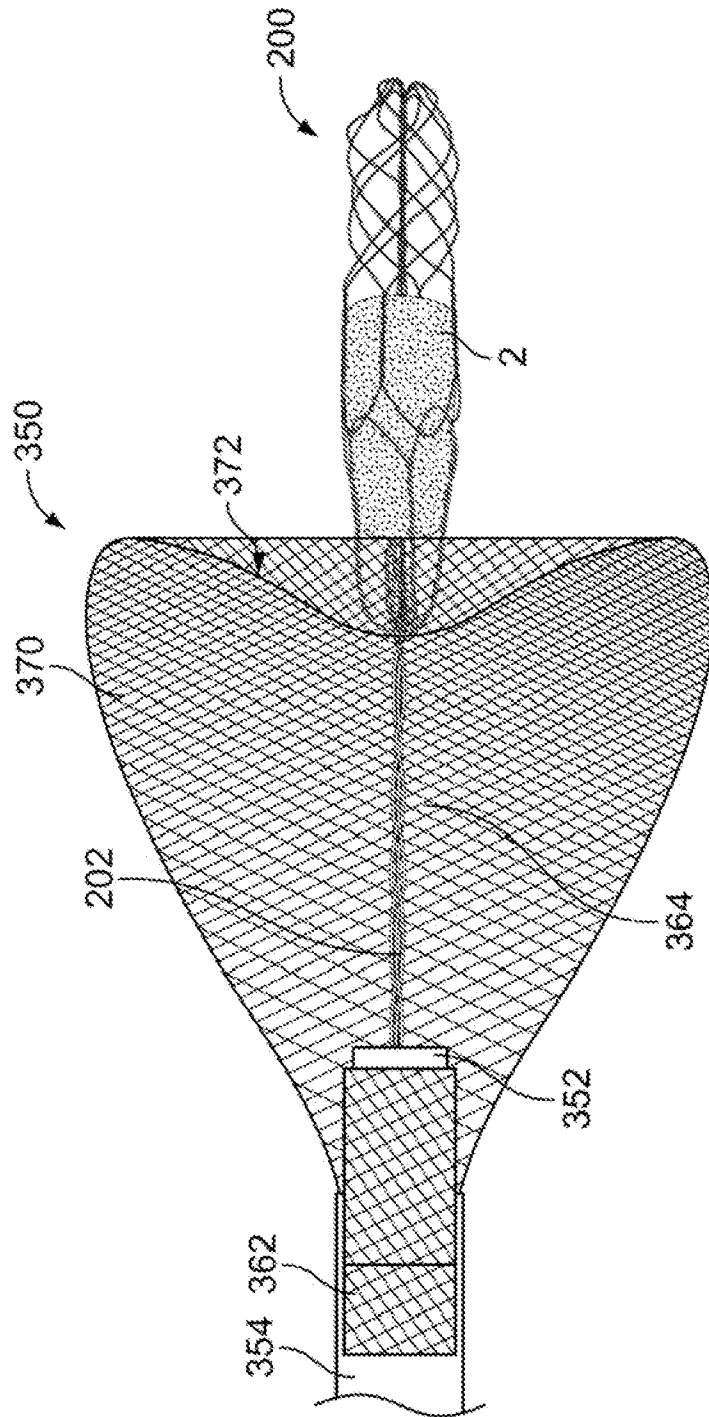

FIG. 13E

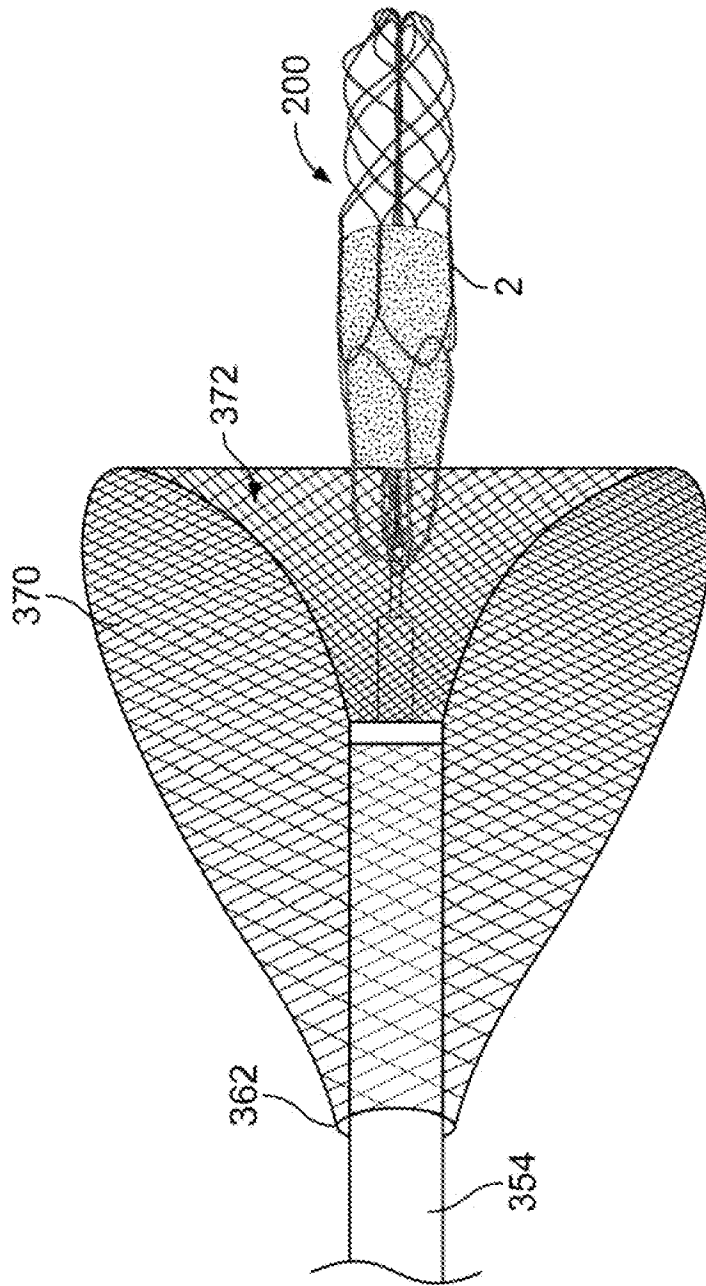

FIG. 13G

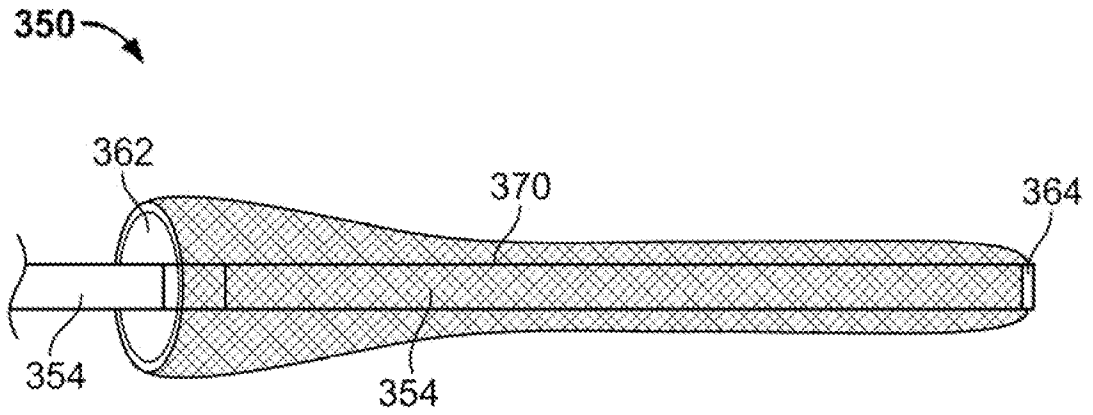

FIG. 13F

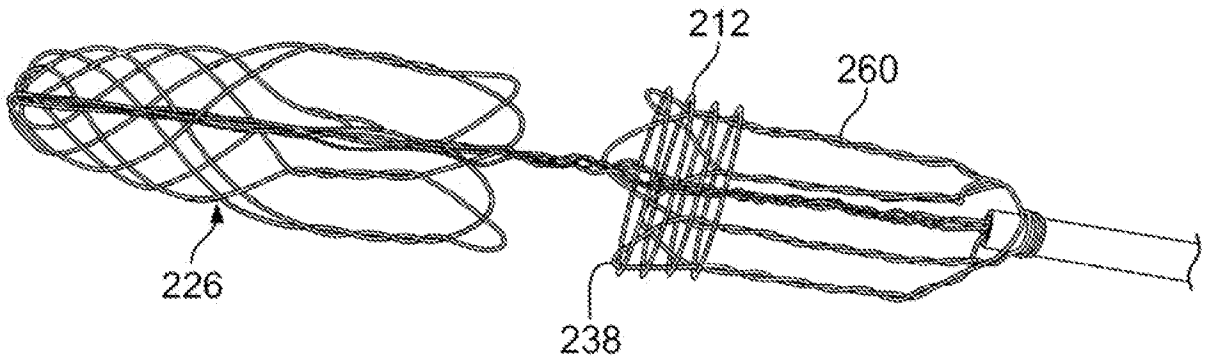

FIG. 14A

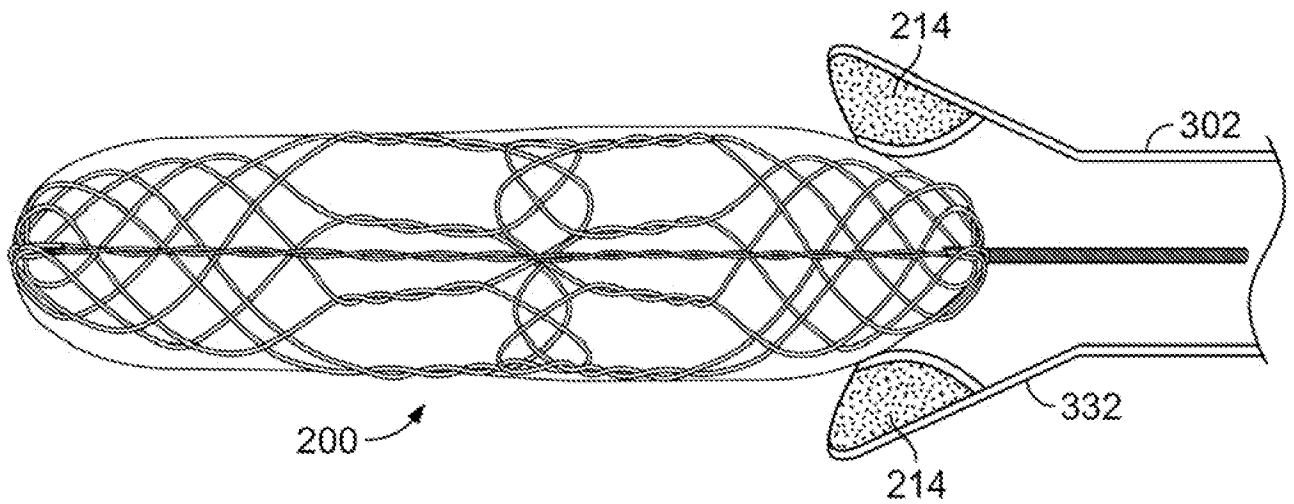

FIG. 14B

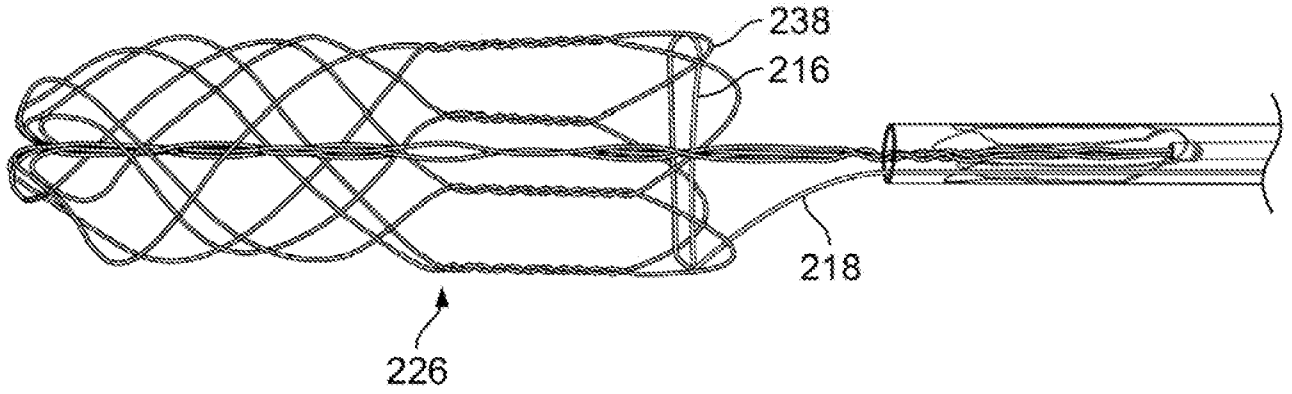

FIG. 14C

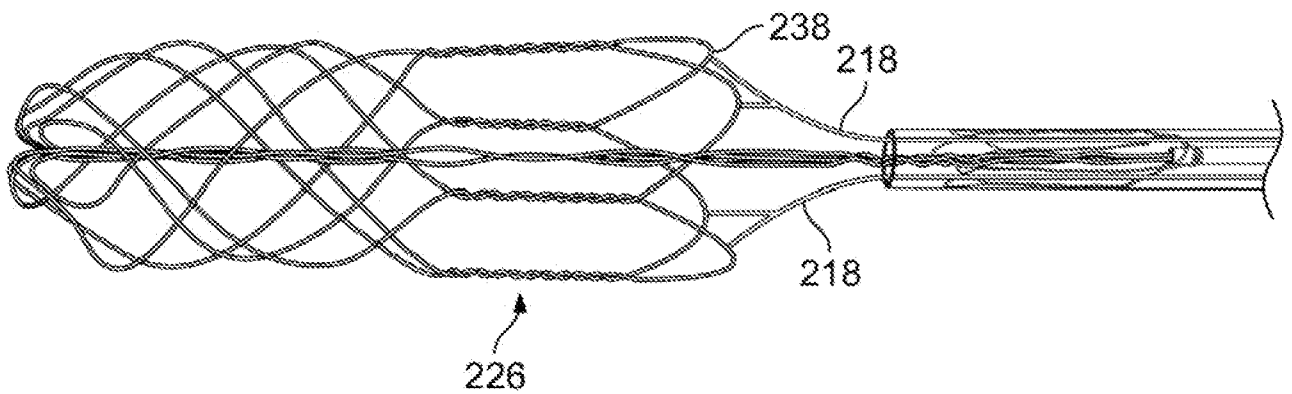

FIG. 14D

INTERNATIONAL SEARCH REPORT

International application No.

PCT/US 08/88371

A. CLASSIFICATION OF SUBJECT MATTER

IPC(8) - A61B 17/22 (2009.01)

USPC - 606/200

According to International Patent Classification (IPC) or to both national classification and IPC

B. FIELDS SEARCHED

Minimum documentation searched (classification system followed by classification symbols)
606/200Documentation searched other than minimum documentation to the extent that such documents are included in the fields searched
A61B 17/221 (2009.01)
606/127, 159

Electronic data base consulted during the international search (name of data base and, where practicable, search terms used)

PubWest, Google

Search Terms Used: obstruction, blood vessel, lumen, wire, capture, removal, catheter, retrieval device, friction,

C. DOCUMENTS CONSIDERED TO BE RELEVANT

Category*	Citation of document, with indication, where appropriate, of the relevant passages	Relevant to claim No.
Y	US 2006/0009784 A1 (Behl et al.) 12 January 2006 (12.01.2006), abstract, para [0009], [0013]-[0014], [0029]-[0030]	1-76, 109-114
Y	US 2007/0225749 A1 (MARTIN et al.) 27 September 2007 (27.09.2007), para [0014]-[0017], [0044], [0082], [0096]-[0098]	1-76, 109-114
Y	US 2005/0090857 A1 (Kusleika et al.) 28 April 2005 (28.04.2005), para [0035], Fig. 4B, para [0066], [0073], [0089], Fig. 8.	18, 20-21, 38-40, 48, 51-64, 66-69, 72-76, 109-114
Y	US 2005/0004594 A1 (Nool et al.) 6 January 2005 (6.01.2005), para [0042], [0077]	53, 73
Y	US 6,221,006 B1 (Dubrul et al.) 24 April 2001 (24.04.2001), Col 16, ln 41-42.	7, 32, 111-112

 Further documents are listed in the continuation of Box C.

* Special categories of cited documents:

"A" document defining the general state of the art which is not considered to be of particular relevance

"E" earlier application or patent but published on or after the international filing date

"L" document which may throw doubts on priority claim(s) or which is cited to establish the publication date of another citation or other special reason (as specified)

"O" document referring to an oral disclosure, use, exhibition or other means

"P" document published prior to the international filing date but later than the priority date claimed

"T" later document published after the international filing date or priority date and not in conflict with the application but cited to understand the principle or theory underlying the invention

"X" document of particular relevance; the claimed invention cannot be considered novel or cannot be considered to involve an inventive step when the document is taken alone

"Y" document of particular relevance; the claimed invention cannot be considered to involve an inventive step when the document is combined with one or more other such documents, such combination being obvious to a person skilled in the art

"&" document member of the same patent family

Date of the actual completion of the international search

5 April 2009 (05. 04. 2009)

Date of mailing of the international search report

16 APR 2009

Name and mailing address of the ISA/US

Mail Stop PCT, Attn: ISA/US, Commissioner for Patents

P.O. Box 1450, Alexandria, Virginia 22313-1450

Facsimile No. 571-273-3201

Authorized officer:

Lee W. Young

PCT Helpdesk: 571-272-4300

PCT OSP: 571-272-7774

INTERNATIONAL SEARCH REPORT

International application No.

PCT/US 08/88371

Box No. II Observations where certain claims were found unsearchable (Continuation of item 2 of first sheet)

This international search report has not been established in respect of certain claims under Article 17(2)(a) for the following reasons:

1. Claims Nos.:
because they relate to subject matter not required to be searched by this Authority, namely:

2. Claims Nos.:
because they relate to parts of the international application that do not comply with the prescribed requirements to such an extent that no meaningful international search can be carried out, specifically:

3. Claims Nos.:
because they are dependent claims and are not drafted in accordance with the second and third sentences of Rule 6.4(a).

Box No. III Observations where unity of invention is lacking (Continuation of item 3 of first sheet)

This International Searching Authority found multiple inventions in this international application, as follows:
In order for more than one invention to be examined, the appropriate examination fees must be paid.
There are considered to be 2 inventions as follows:

Group I: claims 1-76 and 109-114 characterized by the axial strength of the capture wire

Group II: claims 77-108 characterized by a funnel

Groups I and II share the technical feature of a retrieval sheath. This generic feature does not avoid the prior art, as evinced by US 2005/0090857 A1 to KUSLEIKA et al which teaches a common example of such a sheath (para [0046]).

The inventions listed above do not relate to a single general inventive concept under PCT rule 13.1 because, under PCT Rule 13.2 the inventions lack the same or corresponding special technical features. Neither of these technical features is common to the other group nor do they correspond to a special technical feature in the other groups.

1. As all required additional search fees were timely paid by the applicant, this international search report covers all searchable claims.
2. As all searchable claims could be searched without effort justifying additional fees, this Authority did not invite payment of additional fees.
3. As only some of the required additional search fees were timely paid by the applicant, this international search report covers only those claims for which fees were paid, specifically claims Nos.:
4. No required additional search fees were timely paid by the applicant. Consequently, this international search report is restricted to the invention first mentioned in the claims; it is covered by claims Nos.:
claims 1-76 and 109-114

Remark on Protest

- The additional search fees were accompanied by the applicant's protest and, where applicable, the payment of a protest fee.
- The additional search fees were accompanied by the applicant's protest but the applicable protest fee was not paid within the time limit specified in the invitation.
- No protest accompanied the payment of additional search fees.