

M. A. FESLER.  
 OIL BURNER.  
 APPLICATION FILED NOV. 2, 1909.

997,981.

Patented July 18, 1911

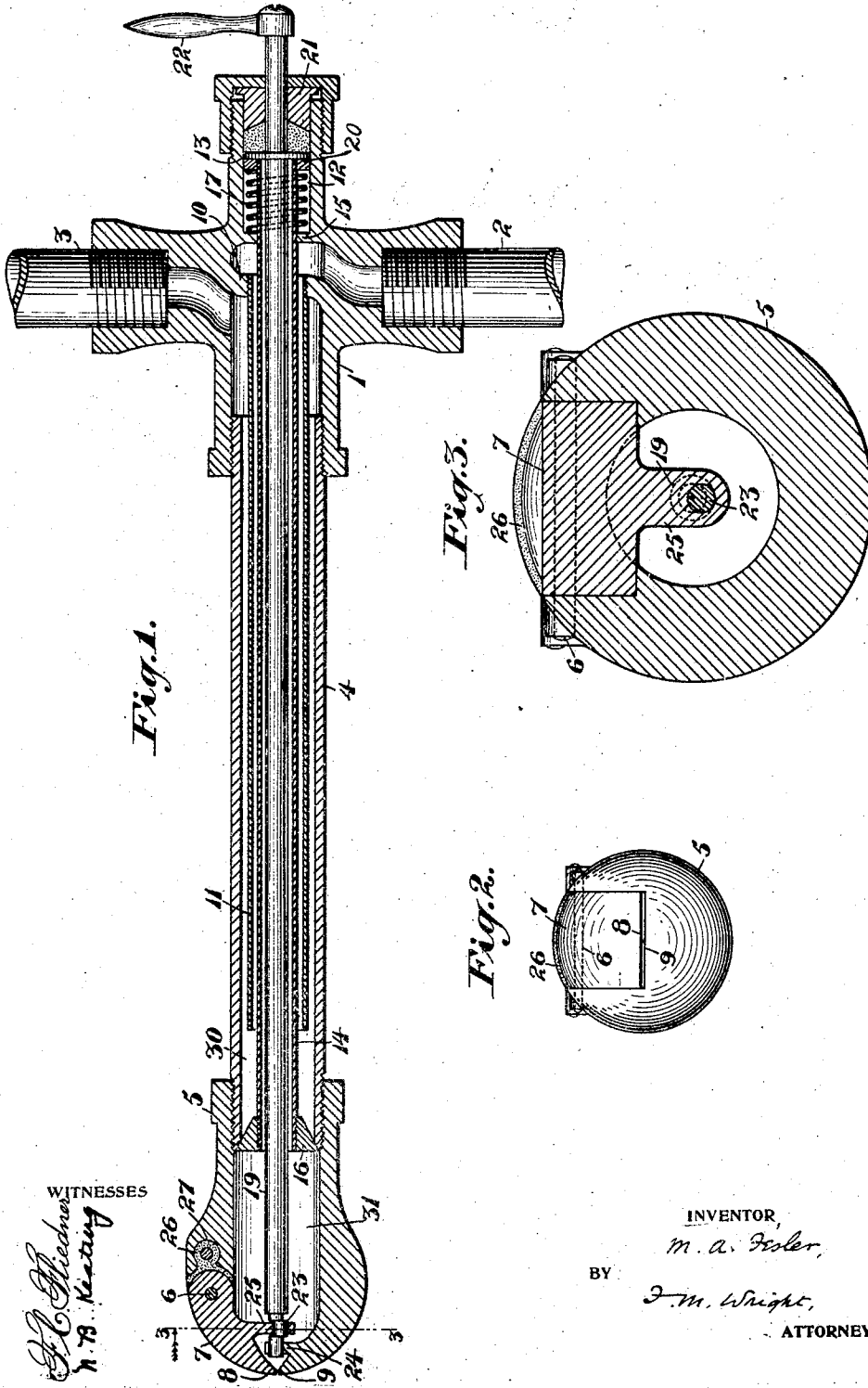

Fig. 1.

Fig. 3.

Fig. 2.

WITNESSES  
*J. C. Mendenhall*  
*H. B. Keating*

INVENTOR,  
*M. A. Fesler*  
 BY  
*J. M. Wright*,  
 ATTORNEY

# UNITED STATES PATENT OFFICE.

MILTON A. FESLER, OF SAN FRANCISCO, CALIFORNIA.

## OIL-BURNER.

997,981.

Specification of Letters Patent. Patented July 18, 1911.

Application filed November 2, 1909. Serial No. 525,881.

To all whom it may concern:

Be it known that I, MILTON A. FESLER, a citizen of the United States, residing at San Francisco, in the county of San Francisco and State of California, have invented new and useful Improvements in Oil-Burners, of which the following is a specification.

The present invention relates to improvements in oil burners, the object of the invention being to provide a burner in which the supply of oil and steam passing through the nozzle may be regulated more conveniently and effectively than heretofore, by which this supply will always escape at uniform pressure, and also having convenient means for varying the size of the opening of the nozzle.

In the accompanying drawing, Figure 1 is a longitudinal section of the burner, certain parts being shown in side elevation; Fig. 2 is an end view thereof; Fig. 3 is an enlarged section on the line 3-3 of Fig. 1.

Referring to the drawing, 1 indicates a cross-shaped union, connected at opposite sides to the oil inlet pipe 2 and the steam inlet pipe 3. It is also connected to the rear end of a steam conduit 4, the front end of which is screwed into the rear end of a nozzle 5, in which is pivoted, on a transverse pivot pin 6, a jaw 7 having a lip 8, forming, with a stationary lip 9 upon the nozzle, a transverse slit through which the mixed steam and atomized oil can be ejected. Screwed in an opening in a partition 10 in said union is the inner end of an oil conduit 11, which extends co-axially within the steam conduit, but terminates within said conduit to form a mixing chamber 30. Said union is also formed, on the opposite side to that to which the steam and oil conduits are connected, with a chamber 12, in which can slide a ring 20, in which is screwed a valve tube 14, said tube sliding through a guideway 15 formed in said casing passing centrally within the oil conduit, and having screwed on its front end a conical valve 16. Said valve is adapted to seat itself against the front end of the steam conduit, and is pressed against said seat by a coiled spring 17 within the chamber 12, said spring being compressed between the guide 15 and said ring 20. Within said valve tube is contained a regulating rod or stem 19, the rear end of said rod

passing centrally through a washer 18 and a stuffing gland 21, and carrying on its rear end a crank handle 22. The front end of said rod is formed with an eccentric or U-crank 23, the front end of which is mounted in a bearing 24 formed upon the nozzle, the eccentric portion thereof passing through a lug 25 depending from the jaw 7. Suitable packing 26 is provided in a recess 27 behind the rounded rear end of said jaw 7.

One advantage of the above burner is its uniform action, due to the fact that the pressure at which the mixture of steam and oil escapes from the mixing chamber 30 into the atomizing chamber 31 is always uniform notwithstanding variations in the pressure of the steam or oil supplied. This escape pressure is determined by the pressure on the coiled spring, which pressure the confined steam and oil must overcome in order to escape. A further advantage resides in the convenient construction for varying the width of the slit through which the mixture of steam and atomized oil escapes from the nozzle, this being effected merely by turning the crank handle 22, the position of which crank shows, at a glance, the width to which said slit has been opened.

I claim:—

1. In an oil burner, the combination of a steam conduit, an oil conduit within the steam conduit, discharging into one end thereof, a valve tube within the oil conduit and projecting beyond said oil conduit to the end of the steam conduit, a valve on said tube adapted to close the end of the steam conduit, a guide for said tube, a coiled spring around said tube, and a device secured upon the end of said tube against which said coiled spring presses to close said valve against the end of the steam conduit, substantially as described.

2. The combination of a cross shaped casing, having a partition, oil and steam pipes connected thereto on opposite sides of said partition, a steam tube connected to a third side, a nozzle on the end of said tube, an oil tube within said steam tube and screwed into said partition, said oil tube terminating within the steam tube, a fourth side of the casing being arranged to form a guide and a chamber, a valve tube guided in said guide and passing through said chamber and having a flange, a spring in said chamber between said guide and flange, and a valve, on

the other end of said valve tube, closing the end of said steam conduit, substantially as described.

3. An oil burner comprising a nozzle, a jaw pivoted on a transverse pivot in said nozzle, tubes for supplying oil and steam to said nozzle, and a stem passing centrally through said tubes and connected eccentrically to said jaw, whereby the turning of said stem moves said jaw, substantially as described.

4. In an oil burner, the combination of co-axial steam and oil conduits, a nozzle secured thereto having a bearing, a jaw piv-

oted transversely on said nozzle, and having a lug, and a stem passing longitudinally through said tubes, the front end of said stem being pivotally mounted in said bearing, and said stem being eccentrically connected to said lug, substantially as described.

In testimony whereof I have hereunto set my hand in the presence of two subscribing witnesses.

MILTON A. FESLER.

Witnesses:

FRANCIS M. WRIGHT,

D. B. RICHARDS.