

Oct. 31, 1933.

S. W. PARSONS

1,932,829

LATCH FOR REFRIGERATOR DOORS AND THE LIKE

Filed Oct. 21, 1931

2 Sheets-Sheet 1

Fig. 1

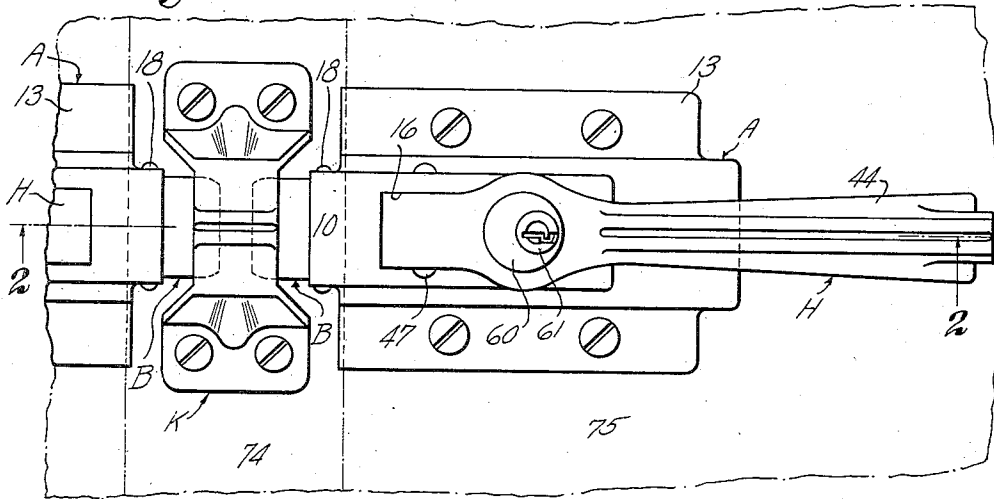
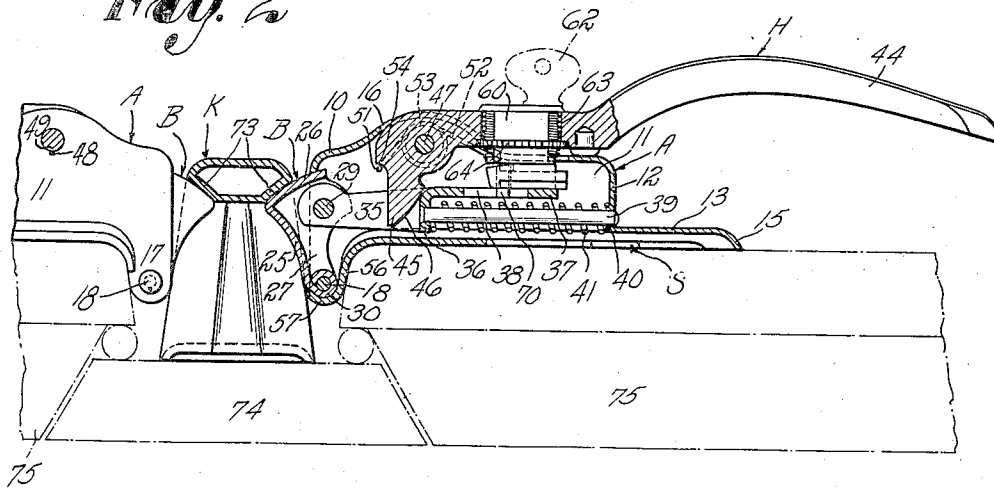

Fig. 2



Inventor
Stuart W. Parsons

By *W. C. Lay Lunday*

Attorney

Oct. 31, 1933.

S. W. PARSONS

1,932,829

LATCH FOR REFRIGERATOR DOORS AND THE LIKE

Filed Oct. 21, 1931

2 Sheets-Sheet 2

Fig. 3

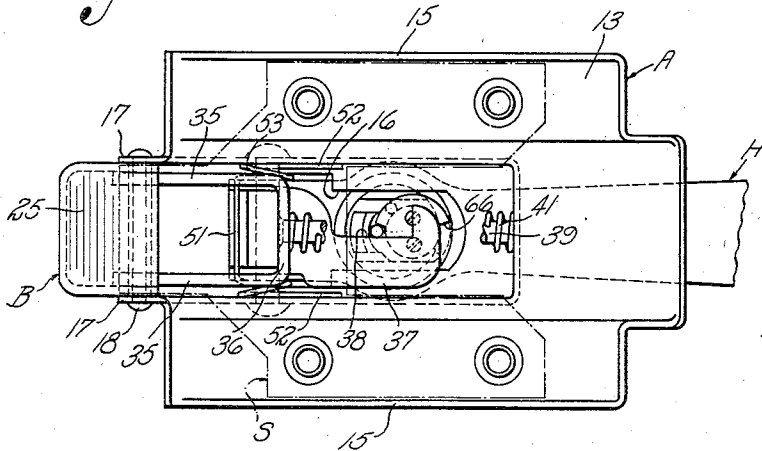

Fig. 4

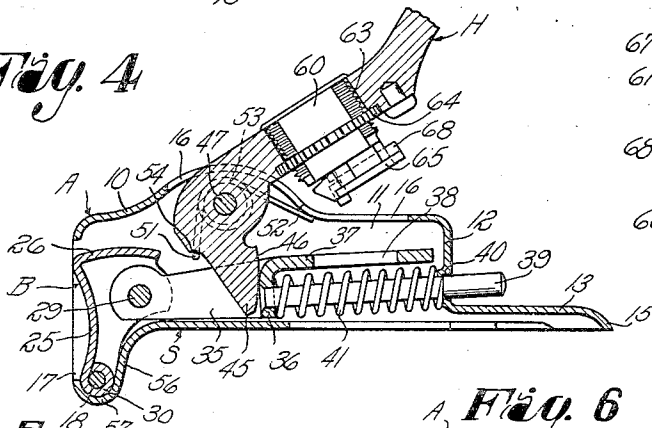

Fig. 5

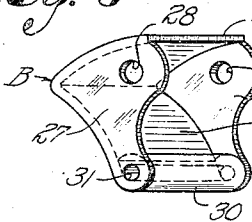

Fig. 6

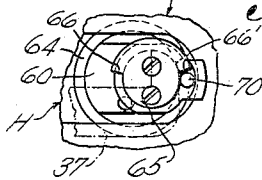

Fig. 7

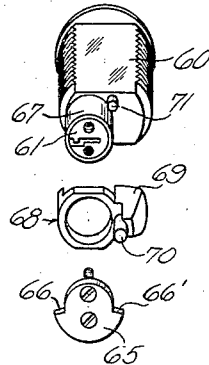
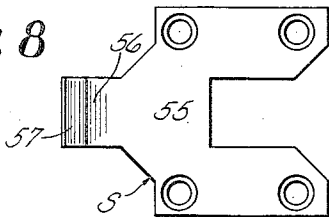

Fig. 8



Inventor
Stuart W. Parsons

By *H. Clay Lindsey*

Attorney

UNITED STATES PATENT OFFICE

1,932,829

LATCH FOR REFRIGERATOR DOORS AND THE LIKE

Stuart W. Parsons, New Britain, Conn., assignor to The Stanley Works, New Britain, Conn., a corporation of Connecticut

Application October 21, 1931. Serial No. 570,053

3 Claims. (Cl. 292—337)

This invention relates to latch devices and particularly to latches for use in connection with refrigerator doors and the like, although the structure of the present invention is not limited to that specific use.

The aim of the present invention is to provide an improved arrangement of latch which is characterized by its simplicity in construction and arrangement, in that it comprises but a relatively few number of parts which may be economically manufactured and assembled; which is characterized by its strength and durability and, therefore, its ability to withstand the strains and shocks to which it is subjected on repeated closing and opening of the door to which it is secured; by its neat and pleasing appearance; by the ease and facility with which it may be operated and the security with which it holds the door in tightly closed condition.

A further aim of the invention is to provide a latch of this sort having a latch member and a pivoted handle for operating the latch member, and wherein the normal position of the operating handle is not disturbed when the latch member is retracted by the strike or keeper upon the closing movement of the door.

A still further aim of the invention is to provide a latch of this sort with simple but effective means for locking the latch against operation either by moving the handle or by surreptitiously "picking" at the bolt.

Other objects will be in part obvious, and in part pointed out more in detail hereinafter.

The invention accordingly consists in the features of construction, combination of elements and arrangement of parts which will be exemplified in the construction hereinafter set forth and the scope of the application of which will be indicated in the appended claims.

In the accompanying drawings, wherein is shown one embodiment which the present invention may take:

Fig. 1 is a front view showing a pair of my improved latches respectively carried by the doors of a refrigerator, and the strike carried by the jamb;

Fig. 2 is a sectional view taken on line 2—2 of Fig. 1;

Fig. 3 is a view looking at the back of the latch;

Fig. 4 is a view taken horizontally through the latch, the operating lever being shown as having retracted the bolt;

Fig. 5 is a perspective view of the bolt;

Fig. 6 is a detail view showing the lock in locking position;

Fig. 7 is a view showing, in perspective, several parts of the lock; and

Fig. 8 is a face view of the saddle or reinforcing plate.

Referring to the drawings in detail, the casing A, which is preferably formed of non-ferrous and rust resisting sheet metal drawn to shape, has a box-like body portion open at the back and having a front or outer wall 10, side walls 11 and a rear end wall 12. Extending from the side and end walls is a base flange 13, the edge of which is turned over as at 15. The front wall has an opening 16 through which the operating lever H extends, and this opening, when the lever is provided with a lock, is of such size as to accommodate the lock, as hereinafter described more in detail. The side walls, at their forward ends, terminate in backwardly extending ears 17 which are suitably apertured to receive a pin 18 on which the bolt B is pivoted.

The bolt B is preferably formed by pressing a sheet of non-ferrous, non-rust metal to the shape illustrated. This bolt has a concave forward wall 25, a parti-cylindrical outer wall 26, and side walls 27, the latter having aligned openings 28 to accommodate a pin 29. The back end of the front wall terminates in a tongue which is rolled back upon itself into cylindrical form so as to constitute a sleeve 30. The side walls 27 also have apertures 31 which register with the hole through the sleeve 30. The apertures 31 and the sleeve receive the pin 18 which is preferably headed at each end so that, after the parts are assembled, they cannot become displaced. By providing the sleeve 30, a good bearing is assured between the bolt and the pin on which it is swivelled, and the bolt itself is reinforced so it is better enabled to withstand the shocks and jars to which it is subjected when the door is slammed shut.

Associated with the bolt is a plunger which includes a yoke member having a pair of arms 35, a cross portion 36 and a tail piece 37 extending rearwardly from the edge of the cross piece. By preference, the yoke and the tail piece 37 are formed from a single piece of metal. The tail piece, at one side, is notched as at 38. The plunger also includes a stem 39 secured to and extending rearwardly from the cross piece in substantial parallelism with the tail piece. The rear end of the plunger is slidably accommodated by an extruded opening 40 in the rear wall 12 of the casing. About the plunger, and between the rear wall 12 of the casing and the cross piece 36

of the yoke, is a compression spring 41 which normally urges the plunger and the bolt into forward or latching position.

The operating lever, designated generally by the letter H, has a long arm 44 constituting a handle, and a short arm 45 extending into the space between the arms 35 of the yoke. The short arm 45 has a curved rear face 46 adapted to engage against the forward face of the cross piece 36 of the yoke. By curving the face 46, friction is reduced. The lever is pivoted on a pin 47 extending through and supported by the side walls 11 of the casing. By preference, the pin 47 is held against rotation with respect to the casing in order to prevent wear therebetween which would result in looseness of the parts. To this end, the opening in one of the side walls may have a notch 48, and the pin may have a projection or fin 49 fitting in the notch, as shown most clearly at the left-hand end of Fig. 2. For the purpose of normally urging the lever to its normal or inoperative position shown in Fig. 2, a spring is directly associated with the lever. This spring, which is formed of a length of spring wire, is generally of U shape so as to provide a cross portion 51 and a pair of arms 52 which straddle the lever where it is pivoted. Each of the arms of the spring has a turn 53 through which the pin 47 extends. The free ends of the arms 52 engage against the back face of the front wall 10, as shown most clearly in Figs. 3 and 4. The cross piece 51 engages a shoulder 54 on the forward face of the lever.

The letter S designates a reinforcing plate or saddle which is arranged to assist the casing in supporting the bolt. This saddle is in the form of a plate having a body portion 55 which fits between the turned-over upper and lower edges 15 of the casing; that is to say, the side flanges of the casing receive the side edges of the saddle, as clearly shown in Figs. 3 and 4. The saddle has, at its forward end, a tongue 56 bent backwardly and curled at its free end so as to form a seat or cradle portion 57 which closely receives the sleeve 30 of the bolt. Thus the bolt has a bearing on the pin 18 which is carried by the ears 17 of the casing, and it also has a bearing in the cradle portion of the saddle. With this arrangement, the saddle takes up some of the strains to which the bolt is subjected and prevents the ears 17 from breaking.

For the purpose of preventing unauthorized persons gaining access to the interior of the ice-box, the latch may be provided with means for locking it in latched position, and, to this end, I provide, in accordance with the present invention, a lock which is preferably carried by the handle, an arrangement which lends simplicity to the construction and economy in its manufacture and assembly. A lock of any suitable type may be employed, but, in the drawings, there is shown, by way of illustration, a lock of the key-operated tumbler type. As locks of this kind are old and well known, the internal construction is not shown in the present instance. It is sufficient to say that it has a body member 60 in which is journaled a rotatable element or tumbler 61 adapted to be turned by a key 62. In the present illustrative disclosure, the handle, rearwardly of its pivotal point, has an opening 63 in which the body member 60 is locked by a nut 64. To the inner end of the rotatable element 61 is secured a disk 65 having one-half of its perimeter of reduced diameter so as to provide diametrically opposite shoulders 66 and 66'. Rotatably

mounted on a tubular extension 67 of the body member 60 is a locking element 68 having an outwardly extending lug 69 which, when the lock is in locking position, engages behind the outer wall of the casing at the rear end of the opening 16 so that the handle cannot be moved from normal position. The locking member also carries a projection or stud 70 adapted to be engaged by the shoulders 66 and 66' of the disk 65. This stud or projection engages behind the tail piece 37 of the plunger when the device is locked so that no one can, by tampering with the bolt itself, surreptitiously "pick" the lock. A pin or stop 71 limits the extent of rotation of the locking elements 68 to 180 degrees.

The keeper K may be of any suitable construction, it here being shown of the double type in order that two latches may cooperate therewith. It is preferably formed of sheet metal. The keeper has a strike portion with a curved wall 73 with which the curved outer wall 26 of the bolt is adapted to cooperate, these two walls being so arranged that the door is more or less cammed shut under the influence of the compression spring 41. The keeper is shown as being secured to the jamb piece 74 of a refrigerator or the like. The doors, which are shown by broken lines, are designated generally by the numeral 75.

The operation of the improved latch forming the subject matter of the present invention will be readily understood from the foregoing description taken in connection with the accompanying drawings. When the operating lever is moved from the normal position shown in Fig. 2 to the operated position, shown in Fig. 4, the plunger and the bolt are retracted, the spring 41 being placed under greater compression. When the handle is released, the spring 41 will automatically move the plunger and bolt forwardly, and the handle will be returned to its normal position. When the bolt is retracted by the keeper as the door is swung shut, the operating lever is not affected as the same will be maintained in its normal position by the relatively lighter spring, and thus the shocks on the handle are avoided and the annoyance caused by the handle flapping or rattling is prevented. When the lock is in unlocked condition, the handle may be operated. When it is desired to lock the latch against operation, the tumbler or rotary element 61 of the lock is turned by means of the key in a clockwise direction with reference to Figs. 3 and 6, whereupon the shoulder 66 of the disk will engage the stud 70 and cause the locking element 68 to be moved to a position where the lug 69 is behind the front wall of the casing and the stud 70 is behind the tail piece 37 of the plunger. Neither the handle nor the bolt can now be operated. When it is desired to unlock the latch, the key is turned in the opposite direction so as to bring the parts back to the position shown in Fig. 3.

As many changes could be made in the above construction and many apparently widely different embodiments of this invention could be made without departing from the scope thereof, it is intended that all matter contained in the above description or shown in the accompanying drawings shall be interpreted as illustrative and not in a limiting sense.

It is also to be understood that the language used in the following claims is intended to cover all of the generic and specific features of the invention herein described and all statements of the scope of the invention which, as a matter of language, might be said to fall therebetween.

I claim as my invention:

1. In a latch for refrigerator doors and the like, a casing, a pin carried by said casing, a bolt pivoted on said pin, a spring pressed plunger hingedly connected to said bolt, an operating lever pivoted in said casing and cooperating with said plunger, and a saddle plate having a cradle in which said bolt has a bearing.

2. In a latch for refrigerator doors and the like, a casing, a pin carried by said casing, a bolt having a sleeve portion through which said pin extends, an operating lever associated with said bolt for retracting the same, and a saddle plate having a body portion located behind said casing, said saddle plate having a cradle concentric to said sleeve and constituting a bearing for the sleeve.

3. In a latch for refrigerator doors and the

like, a casing having a pair of side walls, a front wall, a rear wall and base flanges extending from the side walls, said base flanges having turned-over edges, said side walls having at their forward ends backwardly extending ears, a pin carried by said ears, a bolt pivoted on said pin and having a sleeve portion thereabout, a spring pressed plunger connected at its forward end to said bolt and slidably mounted in the rear wall of the casing, an operating lever pivoted in the casing and cooperating with said plunger, and a saddle plate having a body portion fitting in the base flanges of said casing, said saddle plate having a backwardly turned tongue terminating in a curved seat constituting a bearing for the sleeve of said bolt.

STUART W. PARSONS.

20 85
25 100
30 105
35 110
40 115
45 120
50 125
55 130
60 135
65 140
70 145
75 150