



US 20060148374A1

(19) **United States**

(12) **Patent Application Publication**  
**Mukaida**

(10) **Pub. No.: US 2006/0148374 A1**

(43) **Pub. Date: Jul. 6, 2006**

(54) **TRANSMITTER FOR WIRELESS CONTROL**

(52) **U.S. Cl. .... 446/246; 446/456**

(75) **Inventor: Kenji Mukaida, Tokyo (JP)**

(57) **ABSTRACT**

Correspondence Address:

**YOUNG & THOMPSON**  
**745 SOUTH 23RD STREET**  
**2ND FLOOR**  
**ARLINGTON, VA 22202 (US)**

(73) **Assignee: NIKKO CO., LTD., Tokyo (JP)**

To provide a radio control transmitter that generates and transmits a control signal controlling a travelling direction of a toy vehicle, the radio control transmitter comprises: a supporter provided with a bearing section which is spherically recessed at the upper part; a lower case wherein the supporter protrudes through an inner center base; an opening section of an upper case formed at the center wherein the supporter penetrates through; a substrate positioned inside the lower case and perpendicular to the supporter; a plurality of switches which are fixed around a substrate opening section opened on the substrate, and which determine the travelling direction of the toy vehicle; and a control shaft which maintains a plurality of pressing sections positioned on each of the switches, comprising a spherical end axis section which is rotably fixed to the bearing section at the lower part of the control shaft.

(21) **Appl. No.: 10/542,608**

(22) **PCT Filed: Jan. 17, 2003**

(86) **PCT No.: PCT/JP03/00382**

**Publication Classification**

(51) **Int. Cl.**  
**A63H 1/06 (2006.01)**

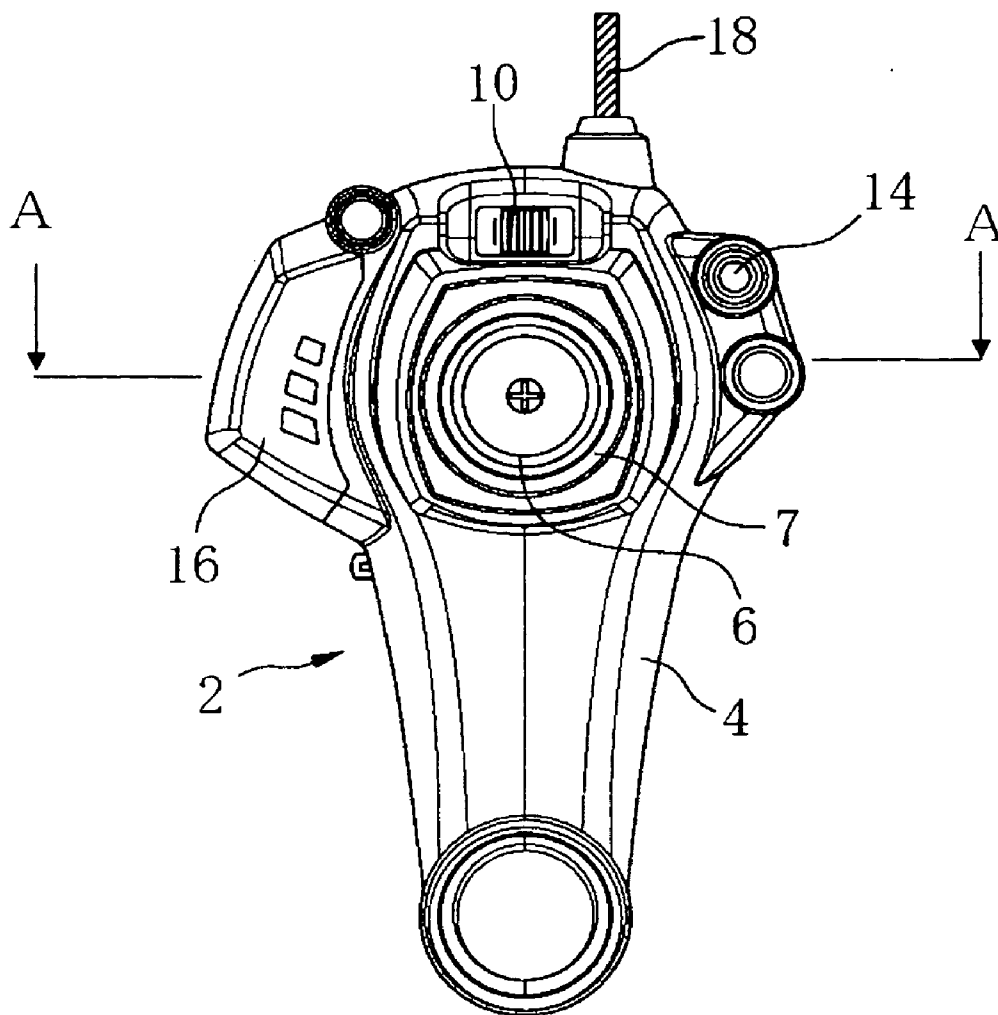

Fig.1

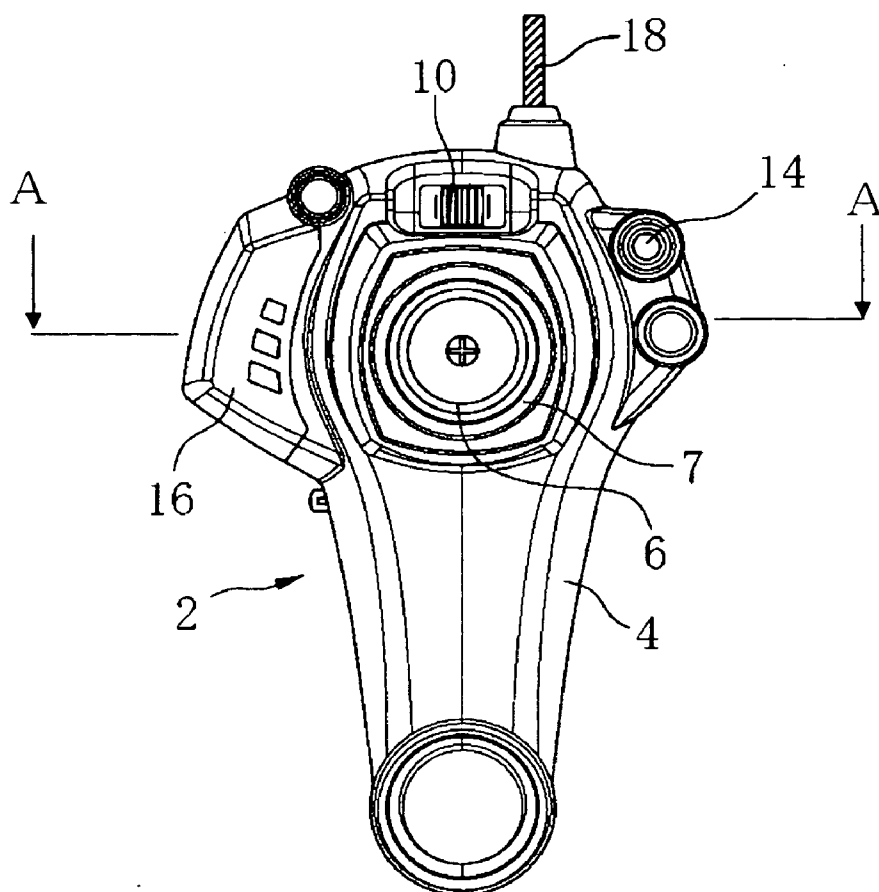

Fig.2

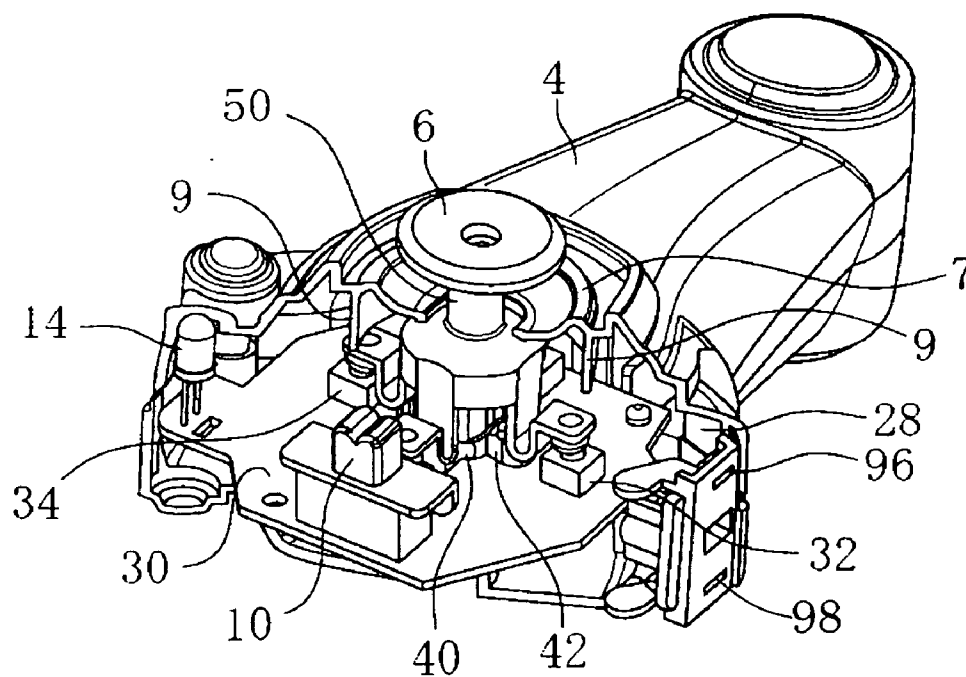

Fig.3

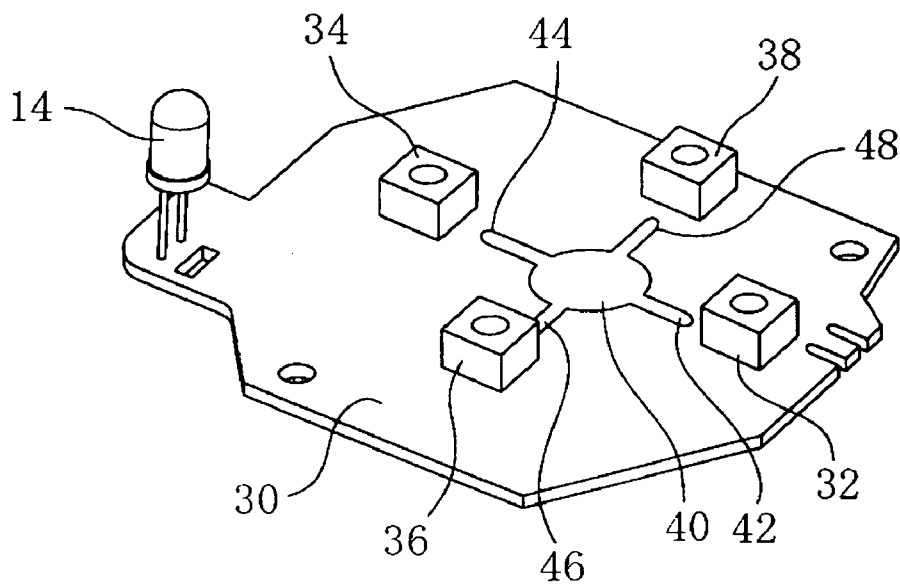

Fig.4

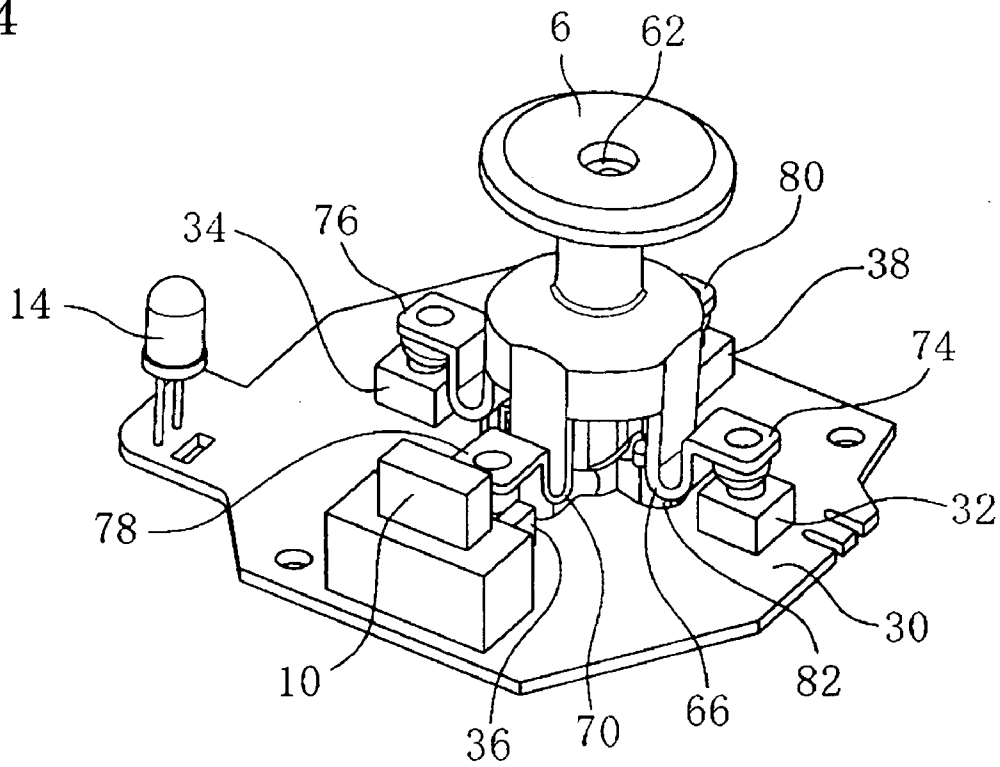

Fig.5

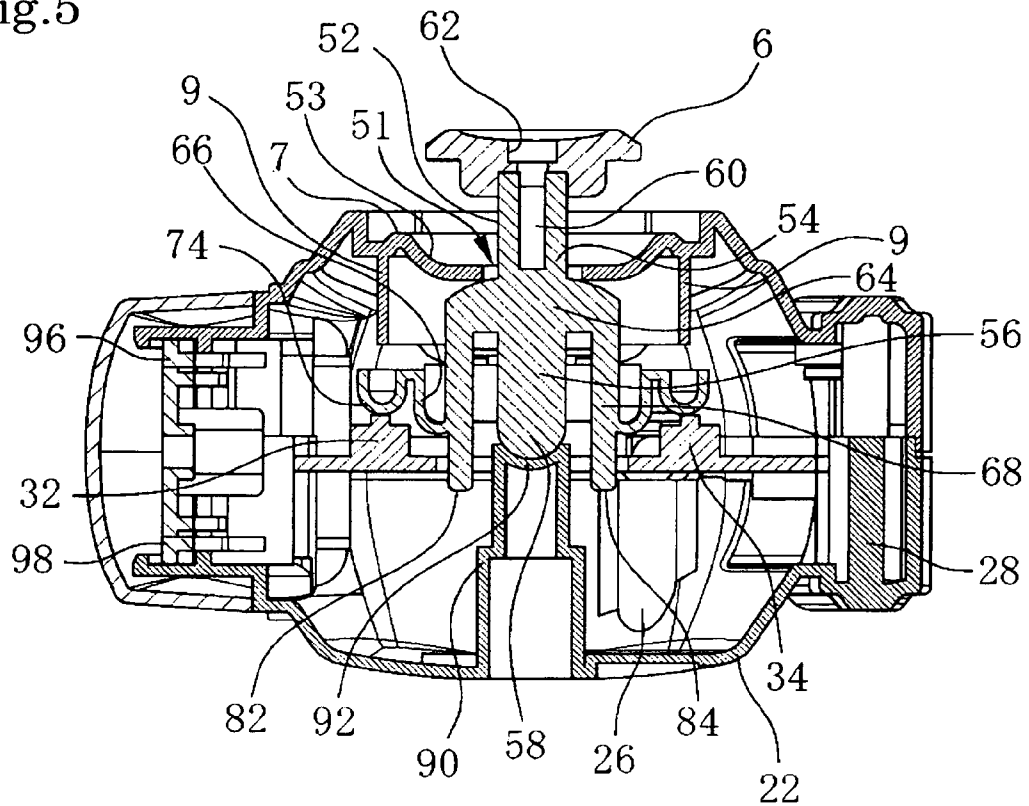
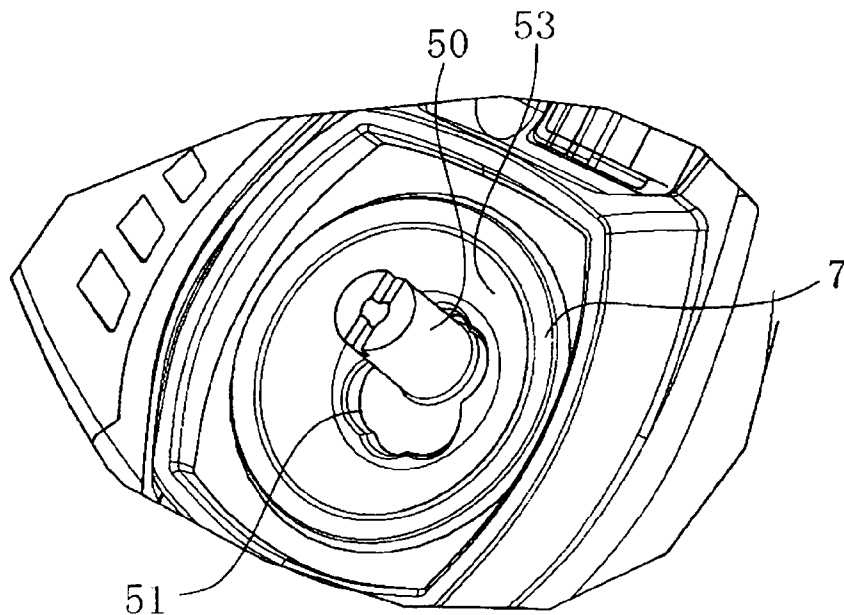

Fig.6



**TRANSMITTER FOR WIRELESS CONTROL**

TECHNICAL FIELD

[0001] The present invention relates to a radio control transmitter having a plurality of switches operable by a single control shaft.

BACKGROUND ART

[0002] Conventionally, the radio control transmitter that manipulates a toy vehicle such as car models, has a configuration in which one channel is assigned to each of forward/backward control and left/right control whereby each channel is manipulated using two sticks (refer to Patent Literature 1: Japanese Laid-Open Utility Model Publication No. 61-7758).

[0003] Moreover, as for the multifunctional controller, the potentiometers positioned in 4 directions are sensing a rotational angle of the U-shaped gutter protruded by joystick is disclosed (refer to Patent Literature 2: Japanese Laid-Open Patent Publication No. 10-214128).

[0004] Furthermore, by rotating and oscillating the control shaft along with impellers, the joystick type control unit that generates a pulse depending on the amount of rotation of the control shaft is disclosed (refer to Patent Literature 3: Japanese Laid-Open Patent Publication No. 9-134251).

[0005] Herewith, the radio control transmitter having two sticks disclosed in Patent Literature 1, normally, a left-hand side stick is used to control the forward and backward movements of a toy vehicle by arranging to act forward and backward with respect to the manipulator. Moreover, the right-hand side lever stick is used to control the left and right movements of a toy vehicle by arranging to act right and left with respect to the manipulator.

[0006] Nevertheless, this configuration is advantageous for the right-handed users who are able to carry out the sensitive control using a dominant hand, but unsuitable for the left-handed user.

[0007] Moreover, according to Patent Literatures 2 and 3, a great number of components requiring processing precision as shown by the devices such as a plurality of wheels or a plurality of U-shaped groove boards are contained to achieve operation of the shafts in 2 directions. Only then its performance is achieved. Accordingly, they have problems such as high resource costs and increase in the processing procedures.

[0008] Therefore, an objective of the present invention is to provide a radio control transmitter of a toy vehicle being easily operable to both the right-handed and left-handed users. Furthermore, a radio control transmitter that comprises a fewer number of components without involving a complex processing.

DISCLOSURE OF INVENTION

[0009] In order to solve the aforementioned problems, according to claim 1 of the present invention, a radio control transmitter that generates and transmits a control signal controlling a travelling direction of a toy vehicle, which comprises: a supporter provided with a bearing section which is spherically recessed at the upper part; a lower case wherein the supporter protrudes through an inner center

base; an opening section of an upper case formed at the center wherein the supporter penetrates through; a substrate positioned inside the lower case and perpendicular to the supporter; and a plurality of switches which are fixed around a substrate opening section opened on the substrate, and which determine the travelling direction of the toy vehicle; and a control shaft which maintains a plurality of pressing sections positioned on each of the switches, comprising a spherical end axis section which is rotably fixed to the bearing section at the lower part of the control shaft.

[0010] According to the radio control transmitter of claim 2 of the present invention, wherein each pressing section corresponds to the plurality of switches, and is held by the other end of an elastic section that hangs down to an edge part of a rib which surrounds the center of the control shaft, and each pressing body is positioned by preparing a predetermined space from each pressing body in a downward direction to the top part of the switch.

[0011] According to the radio control transmitter of claim 3 of the present invention, wherein the rib installs a lead axis being inscribed to each elastic section and extending downwardly.

[0012] According to the radio control transmitter of claim 4 of the present invention, wherein the elastic section is a combination of the rib and a U-shaped spring.

[0013] According to the radio control transmitter of claim 5 of the present invention, wherein the opening section on the substrate comprises a circular section on the same axis as the control shaft, and grooves extending out from the control shaft towards the direction of the switches.

[0014] According to the radio control transmitter of claim 6 of the present invention, wherein the switches are positioned on the substrate in line symmetry including the control shaft.

[0015] According to the radio control transmitter of claim 7 of the present invention, wherein the switches are positioned on the substrate in point symmetry with respect to the control shaft.

[0016] According to the radio control transmitter of claim 8 of the present invention, wherein the control signal is transmitted at a very high frequency or by being multiplexed into an infrared ray.

[0017] According to the radio control transmitter of claim 9 of the present invention, wherein the switch has a lighting section that flashes if the switch is serially connected to the lightning section and selected.

[0018] According to the radio control transmitter of claim 10 of the present invention, wherein the toy vehicle installs a battery as a built-in power source and a chargeable connector terminal which is connected to the battery, that comprises a chargeable connector terminal connected to a built-in power source of a radio receiver and connectable to the chargeable connector terminal installed inside the toy vehicle.

BRIEF DESCRIPTION OF DRAWINGS

[0019] FIG. 1 is a front view showing an embodiment of a radio control transmitter in accordance with the present invention.

[0020] FIG. 2 is an oblique projection drawing showing an embodiment of a radio control transmitter of which is opened in part in accordance with the present invention.

[0021] FIG. 3 is an oblique projection drawing an embodiment of a substrate of the radio control transmitter from which every component is taken out except for switches, in accordance with the present invention.

[0022] FIG. 4 is an oblique projection drawing of a substrate showing an embodiment of a radio control transmitter in accordance with the present invention.

[0023] FIG. 5 is a cross-sectional view AA of FIG. 1 of an embodiment of a radio control transmitter in accordance with the present invention.

[0024] FIG. 6 is a partial view showing an upper case opening section 51 of an embodiment of a radio control transmitter in accordance with the present invention.

#### BEST MODE FOR CARRYING OUT THE INVENTION

[0025] Other details, advantages and characteristics of the present invention will be apparent from the following embodiments to be described with reference to the accompanying drawings.

[0026] FIG. 1 is a front view showing an embodiment of a radio control transmitter 2 in accordance with the present invention. The radio control transmitter 2 comprises a manipulation knob 6 uprightly standing through an upper plane of the upper case 4 covering the radio control transmitter 2; a window section 7 providing an opening section at the center whereby the root of the manipulation knob 6 penetrates through, which is covered by the manipulation knob 6; a power switch 10 mounted at the edge far from the manipulation knob 6; a charged LED 14 mounted adjacent to the manipulation knob 6 that flashes during the charging of toy vehicle at its charging section; a charging section mounted on the left side of the manipulation knob 6 and a cover 16 for the charging section; and a radio transmission antenna 18 mounted on the power switch 10.

[0027] Furthermore, the configuration in accordance with the present invention shall be described by using FIGS. 2 to 5. FIG. 2 is an oblique projection drawing showing the upper side of the manipulation knob 6 of the radio control transmitter 2, and illustrating the inside radio control transmitter 2 by cutting a part of the case. An opening section 51 is formed along an outer periphery of the manipulation knob 6.

[0028] As shown in the cross section, a substrate 30 is positioned on a plurality of ribs 26 and 28, which uprightly stands from an inner base plane of the lower case 22 covering the lower part of radio control transmitter 2, which are located at the root of the manipulation knob 6.

[0029] The window section 7 is prepared below the manipulation knob 6 of the upper case 4. The opening section 51 is prepared in the center of the window section 7. Moreover, a down facing rib 9 is hanging down which is prepared on the inner side of the upper half case to follow around the periphery of the window section 7 to define a circular arc.

[0030] FIG. 3 is an oblique projection drawing of the substrate 30 whose every component is taken out from the

radio control transmitter 2, leaving the push switches 32, 34, 36 and 38 assembled on the surface of the substrate 30, viewed in the same direction as that of FIG. 2. FIG. 4 is an oblique projection drawing of the substrate 30 that assembles all components, viewed in the same direction as that of FIG. 3.

[0031] As shown in FIGS. 3 and 4, push switches 32, 34, 36 and 38 are arranged in point symmetry with respect to a center axis (regularly spaced in a circle at 90 degrees from one another around a center axis). At the center of the substrate 30, a circular opening 40 having a pre-determined diameter is prepared, and the grooves 42, 44, 46 and 48 are formed towards the directions of each of the push switches 32, 34, 36 and 38. In other words, an opening section 40 is formed that combines the shapes of "cross" and "circle".

[0032] Push switches 32, 34, 36 and 38 are the switches that allow the electric currents to pass through upon pressing the switches. A spring having an appropriate spring constant is inserted inside the pressing section of the switch. The conductor inside the switch is connected upon pressing the switch. The spring releases the conductor connection upon releasing the switch.

[0033] Control shaft 50 is set in position through the opening section 40 of the substrate 30. The control shaft 50 is indicated by referring to FIG. 5. The control shaft 50 comprises: a top section 52 connected to the manipulation knob 6; a rib section 54 structured for pressing the push switches 32, 34, 36 and 38; an axis section 56 integrated with the top section 52; and an end axis section 58 which is a base part of the axis section 56.

[0034] The top section 52, which is the upper end of the control shaft 50, has a screw hole 60 at the center of the upper end, and the manipulation knob 6 having a circular screw hole 62 is fixed to the top section 52.

[0035] The rib section 54 is extended from the axis section 56 to a circular hub 64, and the height of the circular hub 64 is lower than the upper case opening section 51 positioned at the point corresponding to the control shaft 50 in the upper case 4. Moreover, a diameter of the circular hub 64 is larger than a diameter of the upper case opening section 51.

[0036] The upper case opening section 51 is positioned at the center of the window section 7 formed on one end of the upper case 4. The form between the opening section 51 and the window section 7 is a bowl form recessed section 53. The axis section 56 protrudes out through the upper case open section 51.

[0037] The edges of the circular hub 64 hangs down parallel to the axis section 56 only at the positions corresponding to the push switches 32, 34, 36 and 38, thereby joining to the U-shaped springs 66, 68, 70 and 72 at a position shorter than the end axis section 58.

[0038] As for the U-shaped springs 66, 68, 70 and 72, their edges are further extended to the same direction as the circular hub 64, so that the pressing sections 74, 76, 78 and 80 are protruded below the extended section. The pressing sections 74, 76, 78 and 80 are positioned, each of which corresponds to each of the push switches 32, 34, 36 and 38.

[0039] The pressing section 68 and each of the push switches 32, 34, 36 and 38 are positioned to allow a space of less than 1 mm apart from one another. The pressing

sections **74, 76, 78, and 80** and each of the push switches **32, 34, 36 and 38** are positioned in point symmetry with respect to the control shaft **50**, which are configured so that the lower edges of the pressing sections **74, 76, 78, and 80** are equal in height with respect to the control shaft **50**. This way, even if the control shaft **50** is naturally tilted to any one direction, since any one of the pressing sections **74, 76, 78, and 80** in the tilted direction is supported by each of the push switches **32, 34, 36 and 38**, so that the control shaft **50** in the neutral position is configured to stand vertically from the substrate **30**.

[0040] On the other hand, the lead axis **82, 84, 86 and 88** extend from the circular hub **64** parallel to the U-shaped springs **66, 68, 70 and 72**. Length of each of the lead axis **82, 84, 86 and 88** is longer than the control shaft **50** but it should be set within the length that does not inhibit a tilt of the control shaft **50**.

[0041] Next, the axis section **56** is integrated with the end axis section **58**. The end axis section **58** is processed to have a spherical shape.

[0042] The control shaft **50** configured as above is loaded on a bearing supporter **90** which uprightly stands at the center of the inner base plane of the lower case **22**. The bearing supporter **90** installs a bearing section **92** that is spherically recessed at the uppermost section. The height of the bearing supporter **90** is almost identical to the substrate **30** supported by the plurality of ribs **26 and 28**, which is positioned so that the upper plane of the substrate **30** and the contact point of the end axis section **58** and the bearing section **92** are equal in height.

[0043] Furthermore, referring to **FIG. 5** illustrating the cross-section AA of **FIG. 1**, a connecting section that sets and charges a toy vehicle is prepared next to the substrate **30**. Electrodes **96 and 98** are respectively positioned and connected to an upper part and lower part of the substrate. Further, the electrodes **96 and 98** are connected to a power source section not illustrated via the power switch **10** prepared on the substrate. For example, if the chargeable electrodes are installed inside a toy vehicle, by contacting the installed chargeable electrodes to electrodes **96 and 98**, a chargeable battery inside the toy vehicle is charged by the electrodes **96 and 98** to which power source voltages are supplied.

[0044] Moreover, as shown in **FIG. 6**, the upper case opening section **51**, a six petal-shaped opening section is prepared. In other words, the open shape has an arc R in 6 directions, and the center of each arc R is positioned to each apex of a hexagon, which is not illustrated. The shape allows the control shaft **50** to shift readily in 6 directions of front, back, front right, rear right, front left and rear left.

[0045] The operations of the radio control transmitter **2** with the above structure in accordance with the present invention will be described.

[0046] First of all, in the neutral state, that is, under the state of no manipulation, even if the control shaft **50** is tilted by its own weight, the neutral state is maintained still, and the pressing sections **74, 76, 78 and 80** are supported by the push switches **32, 34, 36 and 38** having the spring constant not becoming ON state by the weight of the control shaft **50**.

[0047] Next, when the control shaft **50** is tilted in the specific direction, the push switches **32, 34, 36 and 38** are

pressed by the pressing sections **74, 76, 78 and 80**. The push switches **32, 34, 36 and 38** become ON state by pressing the switches with the contracting forces of both springs, each of which is installed in the push switches **32, 34, 36 and 38**, and the U-shaped springs **66, 68, 70 and 72**. Moreover, at this time, the pressing section on the opposite side of the tilted direction is contacted with a downward rib **9** and locked. Because the locking effect works from the downward rib **9** to the direction where the control shaft **50** returns to the neutral position, which facilitates the control shaft **50** to return to the neutral position after finishing the manipulation of the control shaft **50**. Furthermore, since the control shaft **50** is guided by the six petal-shaped opening section **51**, it is movable to 6 directions of front, back, front left, front right, rear left, and rear right.

[0048] Herewith, the lead axis **82, 84, 86 and 88** has a freedom of movement given by a slight looseness in the grooves **42, 44, 46 and 48**, however, the movement is confined within the grooves **42, 44, 46 and 48**, so that the control shaft **50** connected to the lead axis **82, 84, 86 and 88** is configured not to rotate.

[0049] Furthermore, when the control shaft **50** is released so as to cease the tilting of the control shaft **50** in the specific direction, the control shaft **50** returns to its upright position by the repelling forces of both springs in the push switches **32, 34, 36 and 38** and the U-shaped springs **66, 68, 70 and 72**. Although the U-shaped spring come in contact with the push switch positioned opposite to the tilted direction, however, since the pressing force does not exceed the repelling forces of both springs installed in the push switches **32, 34, 36 and 38** and the U-shaped springs **66, 68, 70 and 72**, such that under no circumstance the push switches **32, 34, 36, 38** positioned opposite to the tilted direction become ON.

[0050] As described above, a radio control transmitter that generates and transmits a control signal controlling a travelling direction of a toy vehicle comprises a supporter provided with a bearing section which is spherically recessed at the upper part; a case wherein the supporter protrudes through an inner center base; an opening section of an upper case formed at the center wherein the supporter penetrates through; a substrate positioned inside the lower case and perpendicular to the supporter; and a plurality of switches which are fixed around a substrate opening section opened on the substrate, and which determine the travelling direction of the toy vehicle; and a control shaft which maintains a plurality of pressing sections positioned on each of the switches, comprising a spherical end axis section which is rotably fixed to the bearing section at the lower part of the control shaft. The radio control transmitter is not only simple in configuration but also controls a plurality of switches by using a single control shaft.

[0051] Moreover, each pressing section corresponds to the plurality of switches, and is held by the other end of an elastic section that hangs down to an edge part of a rib which surrounds the center of the control shaft, and each pressing body is positioned in a downward direction by preparing a pre-determined space between each pressing body and the top part of the switch. Now that the pressing section has a multiple functions, this contributes to the deletion of a number of structural components of the radio control transmitter. The rib installs a lead axis being inscribed to each

elastic section and extending downwardly. This prevents the control shaft **50** from becoming uncontrollable by rotating.

[0052] The elastic section is a combination of the rib and an U-shaped spring. The radio control transmitter is not only simple in configuration but also controls a plurality of switches by using a single control shaft.

[0053] The opening section on the substrate comprises a circular section on the same axis as the control shaft, and grooves extending out from the control shaft towards the direction of the switches. This prevents the control shaft **50** from becoming uncontrollable by rotating.

[0054] The switches are positioned on the substrate in line symmetry including the control shaft or in point symmetry. This prevents introducing errors due to a reaction of the control shaft **50** occurred by stopping the pressing force into the control shaft **50**.

[0055] By transmitting the control signal multiplexed into very high frequency wave or an infrared ray, the control signal is capable of transmitting and receiving the transmission media without relying on the specific electromagnetic waves.

[0056] The switch has a lighting section that flashes if the switch is serially connected to the lightning section and selected. Thus, the operability of the switch in use is improved.

[0057] The toy vehicle installs a battery as a built-in power source and a chargeable connector terminal which is connected to the battery, and comprises a chargeable connector terminal connected to a built-in power source of a radio receiver and connectable to the chargeable connector terminal installed inside the toy vehicle, thereby making it possible to comprise a various functions.

[0058] Furthermore, the present invention is not limited to the previously described embodiment, and various modification and improvements to attain the objective of the present invention should be included within the scope of the present invention. For example, in the present invention, 4 switches are positioned in point symmetry, however, 6, 8, or more multiple switches may be positioned for allowing even better control.

[0059] Moreover, the transmission signal used in the above embodiment is the radio signal, however, signal using other electromagnetic waves such as conventional infrared ray is also applicable.

[0060] According to the present invention, in a radio control of a toy vehicle, by allowing users to manipulate a toy vehicle with their dominant hand, it becomes easier for both right-handed and left-handed users to manipulate a vehicle toy. Furthermore, a radio control transmitter is provided without involving a complex processing, which comprises a fewer number of components.

1-10. (canceled)

11. A radio control transmitter that generates and transmits a control signal controlling a travelling direction of a toy vehicle, comprising:

a supporter provided with a bearing section which is spherically recessed at the upper part;

a lower case wherein the supporter protrudes through an inner center base;

an opening section of an upper case formed at the center wherein the supporter penetrates through;

a substrate positioned inside the lower case and perpendicular to the supporter;

a plurality of switches which are fixed around a substrate opening section opened on the substrate, and which determine the travelling direction of the toy vehicle; and

a control shaft which maintains a plurality of pressing sections positioned on each of the switches, comprising a spherical end axis section which is rotably fixed to the bearing section at the lower part of the control shaft, the radio control transmitter further comprising: each pressing section which corresponds to the plurality of switches, and which is held by the other end of an elastic section that hangs down to an edge part of a rib which surrounds the center of the control shaft, and wherein the rib installs a lead axis being inscribed to each elastic section and extending downwardly.

12. The radio control transmitter according to claim 11 wherein the elastic section is a combination of the rib and an U-shaped spring.

13. The radio control transmitter according to claim 11 wherein the opening section on the substrate comprises a circular section on the same axis as the control shaft, and grooves extending out from the control shaft towards the direction of the switches.

14. The radio control transmitter according to claim 11 wherein the switches are positioned on the substrate in line symmetry including the control shaft.

15. The radio control transmitter according to claim 11 wherein the switches are positioned on the substrate in point symmetry with respect to the control shaft.

16. The radio control transmitter according to claim 11, wherein the control signal is transmitted at a very high frequency or by being multiplexed into an infrared ray.

17. The radio control transmitter according to claim 11, wherein the switch is serially connected to a lightning section flashing if the switch is selected.

18. The radio control transmitter according to claim 11, wherein the toy vehicle installs a battery as a built-in power source and a chargeable connector terminal which is connected to the battery, that comprises another chargeable connector terminal connected to a built-in power source of the toy vehicle and connectable to the chargeable connector terminal installed inside the toy vehicle.

\* \* \* \* \*