

G. W. HEY,
DOOR HANGER.

No. 286,539.

Patented Oct. 9, 1883.

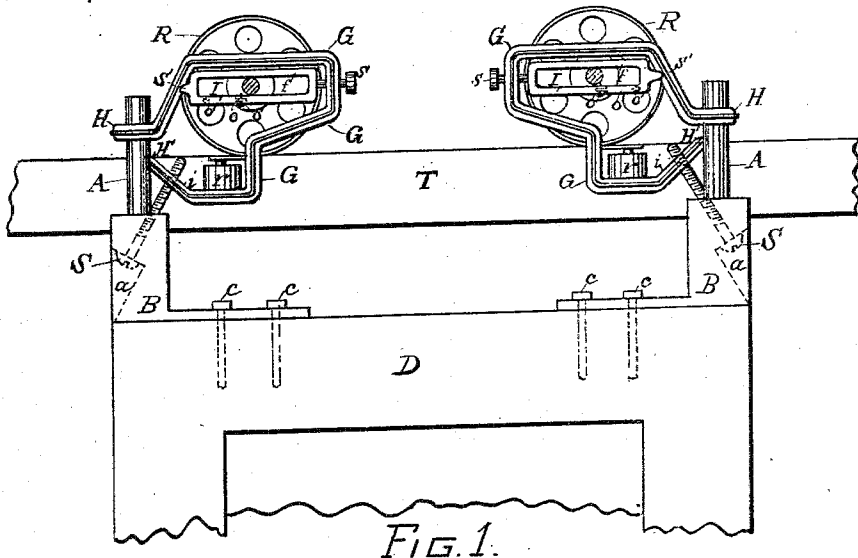

FIG. 1.

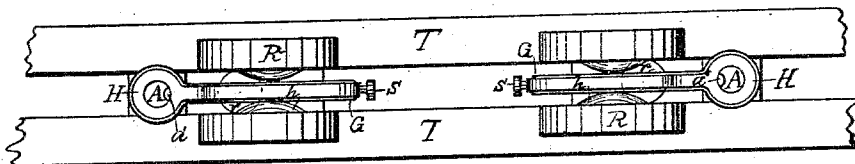

FIG. 2.

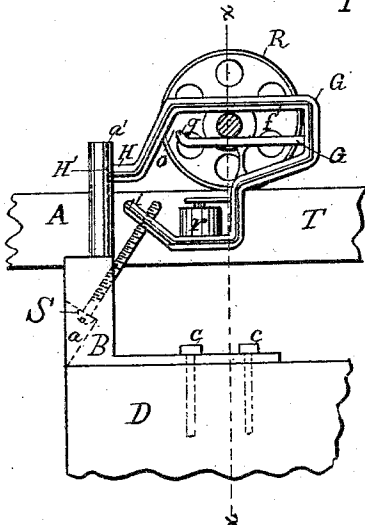

FIG. 3.

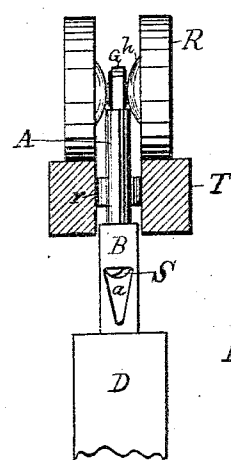

FIG. 4.

WITNESSES

C. Bondison

Wm. B. Raymond

INVENTOR

George W. Hey

(No Model.)

2 Sheets—Sheet 2.

G. W. HEY.
DOOR HANGER.

No. 286,539.

Patented Oct. 9, 1883.

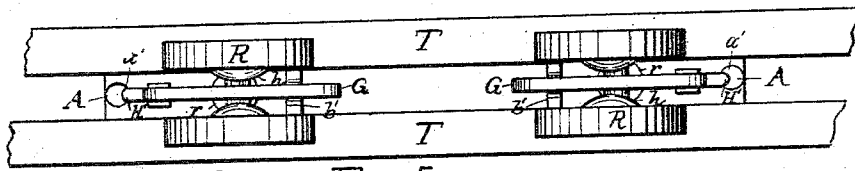

FIG. 5.

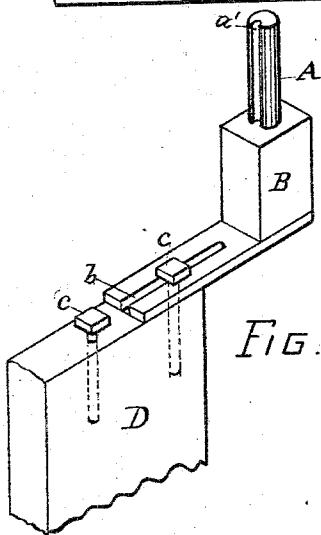

FIG. 6.

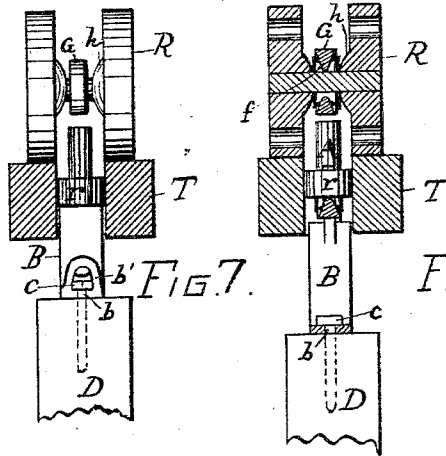

FIG. 7.

FIG. 8.

WITNESSES

C. Bendison

Wm. C. Raymond

INVENTOR

George W. Hey

UNITED STATES PATENT OFFICE.

GEORGE W. HEY, OF SYRACUSE, NEW YORK, ASSIGNOR OF ONE-HALF TO
CHARLES H. DUELL, OF SAME PLACE.

DOOR-HANGER.

SPECIFICATION forming part of Letters Patent No. 286,529, dated October 9, 1883.

Application filed February 26, 1883. (No model.)

To all whom it may concern:

Be it known that I, GEORGE W. HEY, of Syracuse, in the county of Onondaga, in the State of New York, have invented new and useful Improvements in Door-Hangers, of which the following, taken in connection with the accompanying drawings, is a full, clear, and exact description.

This invention relates to the class of house sliding-door hangers, termed "anti-friction parlor-door hangers," in which the journal-bearing is elongated, constituting a rider-bar, which is mounted on the axles of independently-moving carrying-rollers, the object of the invention being to provide a simple, compact, and effective hanger which can be easily and readily applied to the door without cutting or marring the same, and adapted to adjust itself to unevenness in the track-rails, in order to carry the door at all times freely with the least possible friction; and to this end it consists in a frame having an elongated journal-bearing or rider-bar mounted on the axle of an independently-moving carrying-roller having a plain face, said frame being adjustable vertically, and provided with a friction-roller bearing between the track-rails.

It also consists in providing the said journal-bearing with a lateral vibratory support, whereby the carrying-rollers automatically adjust themselves to any unevenness or deflection of the rails.

It consists, also, of a hanger-plate forming, with suitable fastening-screws, the door-attaching device. This plate is slotted horizontally, and is applied on the top of the door, the slot forming a channel or passage for the attaching-screws, which are first inserted into the top of the door and left projecting sufficiently to slide the plate home into position, as fully explained hereinafter. The slotted plate carries a guide-post, and is provided with a recess, through which the adjusting-screw passes.

It also consists in the specific combination, arrangement, and construction of the parts, as more fully specified herein, and pointed out in the claims.

In specifying my improved hanger reference is had to the accompanying drawings, in

which like letters indicate corresponding parts 50
in all the figures.

Figure 1, Sheet 1, is a side elevation, partly in section, showing my improved hanger applied to a door. Fig. 2 is a top plan of the same. Fig. 3 shows a modification in the construction. Fig. 4 is an end view of Fig. 3. Fig. 5 is a plan view of the modification shown in Fig. 3; Fig. 6, detached perspective view of the door-plate and its attaching devices. Fig. 7 is an end view of a modification of the attaching-plate. Fig. 8 is a vertical section taken on the line *x x* in Fig. 3, Sheet 1.

The letter D represents a door hung by my improved hanger.

G is the hanger-frame which is constructed, as shown in the drawings. This frame is provided with an elongated journal-bearing or rider-bar, *f*, which is mounted on the axle of the carrying-roller R. The frame G terminates in extremities H and *i*, the upper extremity or projection, H, forming a guide to steady the frame in its vertical adjustment. The lower extremity, *i*, is provided with a threaded socket, which engages the adjusting-screw S, by which the vertical adjustment is effected. The lower horizontal bar of the frame G forms a bracket or support for the friction-roller *r*, which is attached to the frame in any suitable manner. A laterally-vibratory support, I, for the journal-bearing of the carrying-roller is connected to the frame G by means of pivots *s s'*, Fig. 1, Sheet 1. The pivot *s'* takes in a suitable recess in the outer arm of the frame G, and the pivot *s* may consist of a set-screw passing through the inner arm of the frame, as shown in Fig. 1. The office of this vibratory support is to allow a lateral or tipping movement to the carrying-rollers, whereby they are adapted to automatically adjust themselves to any unevenness in or deflection of the track-rails T. The set-screw *s* allows the ready removal of the support I from its frame G. I preferably construct and connect the support I to the frame G, as shown in Fig. 1, in which case the elongated bearing or rider-bar *f* may be a part of the support itself, as shown in said Fig. 1. The frame G is provided with an opening, *o*, which serves

to allow the carrying-rollers, which are permanently or rigidly affixed to their axle, to be placed in position within the frame G, so that the bar *f* rides on the axle between the rollers.

5 Guards *g*, constructed as shown, are provided, and serve to prevent the bar *f* from running off of the axle at the end of its travel. When a vibratory support, I, is employed, the opening *o* for the introduction of the axle of the carrying-roller can be closed by a section of the lower bar of the support connected by pivots *o'*, Fig. 1, one of which is removable. This construction permits the ready introduction of the carrying-roller, and at the same time insures sufficient strength to make the support practical and durable.

The frame G is adjustably connected to the door through the medium of an attaching-plate, B, Fig. 1. This plate B is best shown in the detached perspective view, Fig. 6, Sheet 2; and it consists of a flat base provided with a longitudinal slot, *b*, which extends about two-thirds its entire length. The outer end of the plate has an upright guide-post, A, which may be cast integral with the base or turned up and affixed in any suitable way. The base of the post A is enlarged and provided with a passage for the adjusting-screw S, and a recess, *a*, which affords access to the said screw S to adjust the door vertically to conform it to the floor or carpet over which it moves. The post A is provided with a groove or curved vertical recess, *a'*, into which the projection on the frame G takes and guides the same vertically when adjusting the door. The projection H of the frame G terminates in an eye which passes over the guide-post A of the plate B, and the adjusting-screw S passes through the recess *a* in the post up into the threaded socket of the lower projection, *i*, of the frame G, and the vertical adjustment is effected by turning the screw S into the socket of the arm *i* of the frame.

To fasten the hanger-plate B to the door it is simply necessary to true up the portion of the top edge of the door over which the plate fits with a plane, then place the plate in position and mark the center of the plate on the door by drawing a pencil within the slot *b*. The plate is then removed and two lag or coach screws, *c c*, Fig. 6, are screwed in vertically and left projecting a turn or two, as shown in the drawings. The other end of the door is treated in the same way, and the hanger-plates, with carrying-rollers and frame all connected, are pushed up through the pocket onto the track T. The door is then raised into position and the plate is slid home in place, the slot *b* sliding under the heads of the screws *c*, as shown at Fig. 6. A flat wrench is then applied to the screws *c*, and a couple of turns sets the screws down firmly and clamps the plate to the top of the door, and the cutting, boring, and marring of the door incidental to all other hangers are entirely obviated, and the application of the hanger to the door so sim-

plified that absolutely no skill is required to apply my improved hanger to the heaviest doors.

When the lateral vibratory support for the journal-bearing of the carrying-roller is constructed and attached to the plate, I construct the inner end of the attaching-plate as shown at *b'*, Fig. 7, Sheet 2. The slot *b* is bridged over, to provide a bearing for the trunnion or pivot S', and the slot is enlarged at *b'*, to allow the passage of the head of the screw *c*.

The carrying-rollers are constructed as shown at Figs. 2, 4, 5, and 7, and consist of plain-faced rollers R, connected by a permanently or rigidly affixed axle. Curved bosses *h* are cast onto the interior hubs of the rollers, and the elongated bearing *f* of the frame G is V-shaped in cross-section, as clearly shown in the vertical sectional view, Fig. 8, Sheet 2. The object of this construction is to provide additional compensation against deflections or unevenness of the rails. This construction gives a slight but delicate adjustment, that aids materially in overcoming friction and securing ease in running. The friction-roller *r* comes between the inner faces of the track-rails T, and serves to keep the plain-faced rollers on the track. The projection *i* of the frame G against the guide-post A is provided with shoulders H', which steady the frame in its vertical movement.

Variations or modifications in the construction and arrangement of the parts of my improved hanger are illustrated at Figs. 3 and 7 of the drawings. Fig. 3 shows a variation in the construction of the projection H of the frame G. In this form the upper projection of the frame is provided with a convex head, taking in the recess *a'* of the post A, and shoulders H', bearing against the vertical edges of the post. In this modification the vibratory support is omitted and the lateral adjustment, in a certain degree, is obtained by the peculiar form of the journal-bearing *f* and the curved bosses *h* of the carrying-rollers, as shown in Fig. 8.

It is obvious that the construction of the adjusting-screw and guide-post can also be modified and varied without departing from my invention—as, for example, the pitch of the screw-passage in the post A can be carried up more nearly parallel to the base, and a vertically-arranged screw-bolt substituted for the upper part of the post. In this case it would be necessary to form a thread in the eye of the projection H of the frame (see Fig. 2, Sheet 1) to engage with the upper or threaded end of the screw-bolt, and the adjustment effected by turning the lower end thereof in the recess *a*, as in the case of the screw S. I therefore do not limit myself to the specific construction shown and described. It is also apparent that the vibratory journal-bearing support and attaching-plate can be combined and used with door-hangers in which the axle of the carrying-roller is confined, so as to move with the

frame. I do not therefore limit these features of my invention to rider-bar door-hangers, as they are adapted to be used in door-hangers of the class shown and described in the United States Letters Patent Nos. 271,980 and 271,981, issued to me on February 6, 1883, and these features are designed as improvements upon the devices shown in my said patents aforesaid.

10 In practice the bottom of the doors are grooved out and a short piece of track is secured to the floor within the opening. The groove passes over this rail, which serves to prevent the door from swaying out of line at the bottom. Stops are usually applied to the inner edges of the doors, to prevent the doors coming too far in the opening when they are closed.

20 Having thus fully described my invention, what I claim as new, and desire to secure by Letters Patent, is—

1. The combination, in a sliding-door hanger, of a carrying-roller loosely mounted in a slotted adjustable frame, a friction-roller journaled in said frame, and an adjusting device for regulating the height of the door.

2. In combination with the independent

moving carrying-roller, a rider-bar mounted on the axle thereof and provided with a lateral vibratory support.

3. In a sliding-door hanger, an attaching device, consisting of a slotted plate, and clamping-screws adapted to enter the slotted plate and secure the same to the door.

4. The combination of the slotted-door attaching-plate, having a vertical guide-post, of the horizontally-pivoted journal-bearing for the carrying-rollers, and its supporting-frame provided with a projection engaging the guide-post, and the adjusting-screw passing through a recess in the post into a threaded seat in frame, as specified.

5. The door-hanger frame G, having elongated bearing *f*, guide-eye in projection H, and threaded socket *i*, substantially as specified.

In testimony whereof I have hereunto signed my name and affixed my seal, in the presence of two attesting witnesses, at Syracuse, in the county of Onondaga, in the State of New York, this 23d day of February, 1883.

GEORGE W. HEY. [L. S.]

Witnesses:

C. BENDIXON,
FREDERICK H. GIBBS.