



- (51) International Patent Classification:
B63H 19/02 (2006.01)
- (21) International Application Number:
PCT/GB2013/000298
- (22) International Filing Date:
9 July 2013 (09.07.2013)
- (25) Filing Language: English
- (26) Publication Language: English
- (30) Priority Data:
GB1212399.8 12 July 2012 (12.07.2012) GB
- (71) Applicant: ECO-NOMIC LTD [GB/GB]; Edgcumbe House, Bere Ferrers, Yelverton, Devon PL20 7JL (GB).
- (72) Inventor: POOLE, Michael; Edgcumbe House, Bere Ferrers, Yelverton, Devon PL20 7JL (GB).
- (74) Agent: AKERS, Noel, James; N.J. Akers & Co., 63 Lemon Street, Truro, Cornwall TR1 2PN (GB).
- (81) Designated States (unless otherwise indicated, for every kind of national protection available): AE, AG, AL, AM,

AO, AT, AU, AZ, BA, BB, BG, BH, BN, BR, BW, BY, BZ, CA, CH, CL, CN, CO, CR, CU, CZ, DE, DK, DM, DO, DZ, EC, EE, EG, ES, FI, GB, GD, GE, GH, GM, GT, HN, HR, HU, ID, IL, IN, IS, JP, KE, KG, KN, KP, KR, KZ, LA, LC, LK, LR, LS, LT, LU, LY, MA, MD, ME, MG, MK, MN, MW, MX, MY, MZ, NA, NG, NI, NO, NZ, OM, PA, PE, PG, PH, PL, PT, QA, RO, RS, RU, RW, SC, SD, SE, SG, SK, SL, SM, ST, SV, SY, TH, TJ, TM, TN, TR, TT, TZ, UA, UG, US, UZ, VC, VN, ZA, ZM, ZW.

(84) Designated States (unless otherwise indicated, for every kind of regional protection available): ARIPO (BW, GH, GM, KE, LR, LS, MW, MZ, NA, RW, SD, SL, SZ, TZ, UG, ZM, ZW), Eurasian (AM, AZ, BY, KG, KZ, RU, TJ, TM), European (AL, AT, BE, BG, CH, CY, CZ, DE, DK, EE, ES, FI, FR, GB, GR, HR, HU, IE, IS, IT, LT, LU, LV, MC, MK, MT, NL, NO, PL, PT, RO, RS, SE, SI, SK, SM, TR), OAPI (BF, BJ, CF, CG, CI, CM, GA, GN, GQ, GW, KM, ML, MR, NE, SN, TD, TG).

Published:
— without international search report and to be republished upon receipt of that report (Rule 48.2(g))

(54) Title: A WAVE POWERED WATER-BORNE VESSEL

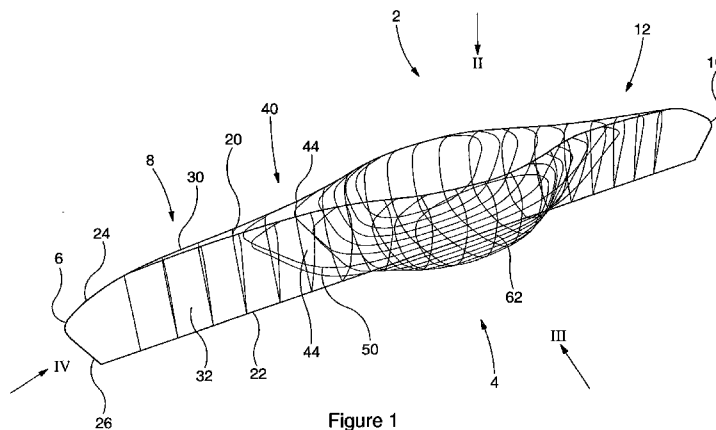

Figure 1

(57) Abstract: A water-borne vessel for propulsion by incident waves is provided, the vessel comprising a hull, the hull of the vessel comprising an elongate bow portion having a length greater than its width at its widest point; an elongate stern portion having a length greater than its width at its widest point; and a central portion between the bow portion and a stern portion, the central portion having a width greater than the widths of the bow and stern portions, the central portion comprising a first flared region at the junction with the bow portion, the first flared portion having a width greater than the width of the adjacent region of the bow portion, and a second flared region at the junction with the stern portion, the second flared region having a width greater than the width of the adjacent region of the stern portion, the central portion having its widest point between the first and second flared regions and greater than the widths of the first and second flared regions; wherein the bow and stern portions act to cut through an incident wave; and wherein the central portion acts to induce the hull to pitch and roll under the action of an incident wave; the vessel further comprising a foil assembly for generating movement of the vessel through the water under the action of an incident wave. A foil assembly for a wave-powered, water-borne craft is also provided, the foil assembly comprising a substantially rigid leading edge assembly having a first end and a second end; a flexible foil extending from the leading edge assembly, the flexible foil having an inner edge and a trailing edge; and a tensioning assembly for tensioning the flexible foil, the tensioning assembly applying a tension to the flexible foil in the direction away from the leading edge assembly and towards the trailing edge of the flexible foil, the tension being provided to the flexible foil at an angle between the inner edge and the trailing edge of the flexible foil.



A WAVE POWERED WATER-BORNE VESSEL

The present invention relates to a water-borne vessel that derives power from
5 the motion of waves.

The use of wave motion to power water-borne vessels is known in the art and
has been the subject of considerable research and development for some time. An
early wave powered boat was developed by Herman Linden of the Zoological
10 Station, Naples in 1895. The boat comprised fins attached to each of the bow and
stern of the boat. The fins were moved through the water and flexed as a result of
the normal pitching and rolling motion of the hull of the boat, thereby generating
forward motion of the boat.

15 GB 551,168 is concerned with the propulsion of boats, rafts and the like.
There is disclosed a propulsive fin having a flexible blade. The fin is oscillated in the
manner of a paddle, to provide propulsion to the craft.

GB 1,176,559 discloses a flexible fin propulsion member for propelling a
20 vessel and a vessel comprising the same. The propulsion member comprises a
generally planar fin having a relatively rigid leading edge portion, the fin decreasing
progressively in rigidity in a direction transverse to the direction of motion of the
vessel. The trailing edge portion of the fin is sufficiently flexible for the fin to be
deformed by the pressure of water on the fin to an inclined or declined attitude.

25 US 3,872,819 concerns a wave actuated horizontal array stretcher for use in
pulling submerged cables, pipes or other assemblies. The stretcher is attached to a
float at the surface of the water and comprises a plurality of pivotal or flexible fins. In
operation, the stretcher is submerged below the water surface and the fins are
30 moved by the wave-induced action of the float at the surface.

US 4,332,571 discloses a wave motor. The motor comprises a supporting
structure extending from the keel of the vessel into the water below the hull. A tilting
element is provided on the supporting structure. The tilting element is biased to a

neutral, horizontal position. In operation, the tilting element is moved from the neutral position by the action of waves on the hull of the vessel, thereby generating forward motion. The biasing means for the tilting element may be a spring or comprise a hydraulic piston.

5

A similar hydraulic system to that of US 4,332,571 is disclosed in US 4,371,347. In this later system, the supporting structure is arranged to move vertically with respect to the hull of the vessel, its movement being restrained by a hydraulic actuating system.

10

During the 1980's, the Hitachi Zosen Corporation began development of a wave-powered vessel. The vessel employed either two horizontal fins mounted side by side under the bow of the vessel or a single foil assembly, again mounted under the vessel bow. Vertical motion of the fins through the water pulls the vessel along.

15

More recently, US 7,371,136 entitled 'Wave power' concerns a wave powered water vehicle. The vehicle comprises a surface float and a fully submerged swimmer. The float and swimmer are connected by a tether, as a result of which the swimmer is caused to move up and down due to the motion of the float induced by incident waves. The swimmer comprises one or more fins. The fins are shaped to induce forward motion of the swimmer as a result of the up and down motion induced by the action of the float. US 7,371,136 describes a number of different configurations for the fins. A first configuration comprises a fin mounted to rotate about an axis that is displaced from a body of the swimmer. In a second configuration, the fin is mounted to move about an axis and is provided with an elastic component, separate from the fin, which deforms under the action of the fin to change the orientation of the fin. In a third configuration, the fin is provided with a leading edge. The leading edge comprises a relatively rigid central portion having a fixed relationship with the swimmer body and a flexible outboard portion. The fins may be arranged to rotate about a longitudinal axis of the swimmer body and are referred to in US 7,371,136 as pectoral fins. The tether may be rigid or elastically deformable. The swimmer body may be rigid. Alternatively, the swimmer body may comprise a flexible portion. A similar assembly is shown and described in US 7,641,524.

20

25

30

JP 2002220082 disclosed a wave-propelled ship equipped with a hydrofoil.

5 Still more recently, Isshiki, H. et al., 'Thrust Generation by Waves',
Proceedings of the Ninth (2010) ISOPE Pacific/Asia Offshore Mechanics
Symposium, Busan, Korea, November 14-17, 2010, provide an overview of aspects
of use waves to propel sea-going vessels.

10 There is a need for an improved wave-powered water-borne vessel. As noted
above, recent developments have concentrated on a vessel comprising a separate
submerged swimmer connected to the vessel by way of a tether. This is necessarily
a complicated arrangement in terms of its construction, deployment and operation,
with the accompanying risk of entanglement with other objects in the water. It would
be advantageous if a simpler system for providing wave-powered propulsion to a
15 vessel could be provided.

It has now been found that the efficiency of a wave powered vessel can be
significantly improved by appropriate design of the hull of the vessel. Prior art
vessels comprised hulls that are designed to rise under the action of the incident
20 waves, in the same manner as the hull of a conventionally powered vessel. It has
now been found that an increase in the power generated from incident waves may be
obtained by providing the vessel with a hull that maximises the movement of the hull
induced by incident waves, in particular pitching and rolling motions of the hull, and
which minimises drag resistance to motion through the waves. Drag resistance is
25 reduced by shaping the hull and/or the bow and stern of the hull to cut through the
incident waves, rather than rising under the action of the waves. This is in contrast to
the hulls of the prior art vessels, which were designed to rise and fall with the surface
of the water as the waves pass the vessel.

30 The efficiency of the vessel in generating propulsion from incident waves is
increased by increasing the tendency of the vessel to pitch and roll under the action
of the waves. In contrast, conventional hull design reduces the tendency of the hull
to pitch and roll, by the flared shape of the bow and, more particularly, the stern of
the vessel. In this way, a conventional hull drives into an incident wave and rises

with the wave, losing energy in the process. It has been found that these effects may be achieved by using a novel configuration for the hull of the vessel.

Accordingly, in a first aspect, the present invention provides a water-borne vessel for propulsion by incident waves, the vessel comprising a hull, the hull of the vessel comprising:

an elongate bow portion having a length greater than its width at its widest point;

an elongate stern portion having a length greater than its width at its widest point; and

a central portion between the bow portion and a stern portion, the central portion having a width greater than the widths of the bow and stern portions, the central portion comprising a first flared region at the junction with the bow portion, the first flared portion having a width greater than the width of the adjacent region of the bow portion, and a second flared region at the junction with the stern portion, the second flared region having a width greater than the width of the adjacent region of the stern portion, the central portion having its widest point between the first and second flared regions and greater than the widths of the first and second flared regions;

wherein the bow and stern portions act to cut through an incident wave; and wherein the central portion acts to induce the hull to pitch and roll under the action of an incident wave;

the vessel further comprising a foil assembly for generating movement of the vessel through the water under the action of an incident wave.

The vessel of the present invention is buoyant and is borne by the water at the water surface. For generating propulsion from incident waves via the motion of the vessel relative to the water, the vessel is provided with one or more foil assemblies, as described in more detail hereinbelow. Movement of the vessel, in particular forward motion, is provided by propulsive forces induced by the movement of the foil assemblies through the water. By having the hull of the vessel formed to increase the tendency of the vessel to pitch and roll under the action of incident waves, propulsion of the vessel is provided more efficiently. The elongated form of both the bow and stern portions of hull allow the hull to cut through waves, allowing

the foil assemblies to remain in contact with the water and to remain in motion relative to the water. In particular, the form of the bow and stern portions allows the or each foil assembly to be positioned and maintained within the incident waves, such that the pitching and rolling motion of the hull induced by the incident waves causes the or each foil assembly to move in the opposite direction to the particle flow of the water in the waves.

The tendency of the hull to cut through incident waves and to be more susceptible to pitching and rolling induced by the action of waves on the vessel is provided by the aforementioned elongated bow and stern portions in conjunction with the flared central portion. In this respect, the term 'elongated' is a reference to the portion having a length that is significantly greater than its width at the widest point. In particular, the term is preferably a reference to a portion having a length that is several times greater than the width of the portion at its widest point.

The hull of the vessel comprises an elongated bow portion and an elongated stern portion. The bow portion and stern portion may be the same or different in form, such as length and width. In one preferred embodiment, the bow portion and stern portion have the same general form and comprise substantially the same portion of the hull, in particular being of substantially the same length.

The elongated bow portion may have any suitable form that acts to cut through an incident wave and reduce the tendency for the bow to rise up or fall down under the action of the wave, as it reaches and passes the bow. In one preferred form, the bow portion has generally flat, planar sides, extending from the upper edge to the lower edge of the hull. The bow portion is preferably tapered, that is the width of the bow portion increases along the longitudinal axis of the hull in the direction from the bow to the stern of the hull. The bow portion is most preferably symmetrical about the longitudinal line of the hull extending from the bow to the stern. In one preferred embodiment, the bow portion is generally triangular in plan view, more preferably having an outline in plan view that is of an isosceles triangle, with the base of the triangle extending laterally across the hull. The sides of the triangle, when taken in plan view, may be substantially straight or may be curved, for example concave.

The bow portion may taper from the upper edge or deck of the hull to the lower edge or keel of the hull. To aid in the bow cutting through incident waves and to minimise the tendency of the bow portion to rise and fall under the action of incident waves, the bow portion is preferably substantially uniform in cross section extending from the upper edge or deck to the lower edge or keel of the hull. If tapered, as mentioned hereinbefore, the bow portion is most preferably wider at its upper portion than its lower portion. More preferably, if tapered in the vertical direction, the bow portion is generally triangular in vertical end section along its length.

In embodiments in which the bow portion is tapered in the vertical direction, part or all of the sides of the bow portion preferably extend at an angle of from 5 to 30° to the vertical axis, more preferably from 10 to 25°, still more preferably from 15 to 20°. It is preferred that the vertical taper of the bow portion increases in the longitudinal direction from the bow to the stern.

The stern portion has a similar form to the bow portion. Thus, the elongated stern portion may have any suitable form that acts to cut through and incident wave and reduce the tendency for the stern to rise up or fall down under the action of the wave, as it reaches and passes the stern. As with the bow portion, in one preferred form, the stern portion has generally flat, planar sides, extending from the upper edge to the lower edge of the hull. The stern portion is preferably tapered, that is the width of the stern portion increases along the longitudinal axis of the hull in the direction from the stern to the bow. The stern portion is most preferably symmetrical about the longitudinal line of the hull extending from the stern to the bow. In one preferred embodiment, the stern portion is generally triangular in plan view, more preferably having an outline in plan view that is of an isosceles triangle, with the base of the triangle extending laterally across the hull. The sides of the triangle, when taken in plan view, may be substantially straight or may be curved, for example concave.

The stern portion may taper from the upper edge or deck of the hull to the lower edge or keel of the hull. As with the bow portion, to aid in the stern cutting through incident waves and to minimise the tendency of the stern portion to rise and

fall under the action of incident waves, the stern portion is preferably substantially uniform in cross section extending from the upper edge or deck to the lower edge or keel of the hull. If tapered, as mentioned hereinbefore, the stern portion is most preferably wider at its upper portion than its lower portion. More preferably, if tapered
5 in the vertical direction, the stern portion is generally triangular in vertical end section along its length.

In embodiments in which the stern portion is tapered in the vertical direction, part or all of the sides of the stern portion preferably extend at an angle of from 5 to
10 30° to the vertical axis, more preferably from 10 to 25°, still more preferably from 15 to 20°. It is preferred that the vertical taper of the stern portion increases in the longitudinal direction from the stern to the bow.

Each of the bow and stern portions may be considered to have a ratio of their
15 length to their width at their widest point. Generally, the widest regions of the bow and stern portions are preferably situated adjacent the central portion. In this way, in embodiments in which the bow and stern portions are tapered in the longitudinal direction, they both increase in width in the direction towards the central portion.

20 In the case of the bow portion, the ratio X of the length of the bow portion to the width of the bow portion is preferably at least 2.5. More preferably, the ratio X is at least 3.0, still more preferably at least 4.0. A ratio X of greater than 4.5 is preferred for many embodiments, more preferably at least 5.0. A ratio X of at least 6.0, more preferably at least 6.5 has been found to be particularly suitable for many
25 embodiments. One preferred embodiment has a ratio X of about 7.75.

In the case of the stern portion, the ratio Y of the length of the bow portion to the width of the stern portion is preferably at least 2.5. More preferably, the ratio Y is at least 3.0, still more preferably at least 4.0. A ratio Y of greater than 4.5 is
30 preferred for many embodiments, more preferably at least 5.0. A ratio Y of at least 6.0, more preferably at least 6.5 has been found to be particularly suitable for many embodiments. One preferred embodiment has a ratio Y of about 7.75.

The bow and stern portions may have the same relative dimensions, that is the ratios X and Y may be the same. Alternatively, the ratios X and Y may be different. In one preferred embodiment, the ratios X and Y are the same.

5 The bow and stern portions may be of the same length or of different lengths. In one preferred embodiment, the bow and stern portions are of the same length. In an alternative embodiment, the bow portion is longer than the stern portion, that is the central portion is displaced towards the stern of the hull.

10 In contrast to the bow and stern portions, the central portion of the hull is relatively wide, compared with the bow and stern portions. The central portion has a flared region adjacent each of the bow and stern portions, each flared region having a width that is greater than that of the respective bow and stern portion. The action of the central portion and the flared regions is to cause the hull to pitch and roll under
15 the action of an incident wave contacting this portion of the hull.

The flared regions of the central portion provide a transition from the elongated form of the bow and stern portions to the generally wider, more bulbous form of the central portion. As noted above, the central portion is generally of a
20 substantially greater width, at its widest point, than both the bow and stern portions. The widest point of the central portion is preferably positioned centrally in the central portion on the longitudinal axis of the hull extending from the bow to the stern. In general, the central portion has an increased width relative to the bow portion and the stern portion, with the increased width being uniform along the vertical axis of the
25 central portion. In this way, the central portion has a substantially uniform increased width extending from the upper edge or deck of the hull to the lower edge or keel.

As noted, the flared regions provide a transition between the respective bow and stern portion and the central portion. In one preferred embodiment, one or both
30 flared regions are arranged to provide the hull with lift, under the action of an incident wave. This lifting action is preferably provided by having the flared region provided with a non-uniform width profile in vertical section. More particularly, the flared region is preferably provided with an upper portion and a lower portion, the upper portion having a width greater than the lower portion. The upper portion is most

preferably disposed above the normal waterline of the hull, whereby incident waves contact the lower surface of the upper portion, thereby generating lift on the hull. This action, in turn induces the hull to pitch and roll. This movement of the hull moves the or each foil assembly through the water, in turn generating movement of the vessel through the water, as described in more detail hereinafter.

The ratio of the width of the upper portion to the width of the lower portion is preferably at least 1.2, more preferably at least 1.5, still more preferably at least 1.75, with a ratio of at least 2.0 being suitable for many embodiments. To provide a transition between the hull or stern portion and the central portion, the flared portion is provided with a transitional surface between the upper portion and the lower portion. This transitional surface is preferably smooth. Preferably, this transitional surface extends at an angle downwards from the upper edge or deck of the hull in the longitudinal direction towards the centre of the central portion. In other words, the upper portion of the flared region increases in height and the lower portion of the flared region decreases in height in the longitudinal direction to the centre of the central portion.

The flared regions may comprise any suitable portion of length of the central portion, sufficient to provide a transition between the bow and stern portions and, preferably, to provide the aforementioned lifting action. Preferably, each flared region comprises at least 10.0% of the length of the central portion, more preferably at least 15.0%, still more preferably at least 17.5%. A flared region forming about 20.0% of the length of the central portion is preferred for many embodiments.

The flared regions may be the same in size and form, or may be different. Preferably, the flared regions are the same and the central portion is symmetrical about its central lateral axis.

The flared regions of the central portion of the hull may be extended into the respective bow and/or stern portions. In this way, the bow and/or the stern portion may be provided with flared regions, adjacent those of the central portion. In this way, the interaction between an incident wave and the flared regions, giving rise to

lifting of the hull and inducing the hull to pitch, is increased and/or accelerated as the wave passes the hull.

In the case of a bow portion comprising a flared region, the flared region may extend to be at or adjacent the bow of the hull. Alternatively, and more preferably, the flared region is spaced from the bow, to allow the bow to cut into and enter an incident wave. In such embodiments, the flared region may be spaced from the bow by 40.0% of the length of the bow portion, more preferably at least 50.0%, still more preferably at least 60.0%.

Similarly, in the case of a stern portion comprising a flared region, the flared region may extend to be at or adjacent the stern of the hull. Alternatively, and more preferably, the flared region is spaced from the stern, as with the bow portion. In such embodiments, the flared region may be spaced from the stern by 40.0% of the length of the stern portion, more preferably at least 50.0%, still more preferably at least 60.0%.

As noted above, the central portion is a wide portion of the hull, relative to the bow and stern portions. In particular, the central portion of the hull preferably has a ratio Z of its length to its width that is no greater than 8.0. More preferably, the ratio Y is less than 6.0, preferably less than 5.0, still more preferably less than 4.0.

As noted above, the central portion is substantially wider at its widest point than the widest points of the bow and stern portions. Preferably, the ratio of the maximum width of the central portion to the maximum width of the bow or stern portions is at least 2.0, more at least 2.5, still more preferably at least 3.0. A higher ratio is generally preferred, that is preferably at least 3.5, more preferably at least 4.0, still more preferably at least 4.5. A ratio of at least 5.0 is particularly preferred for many embodiments. A ratio of about 5.5 is particularly suitable.

The central portion is preferably symmetrical about its longitudinal axis.

It is to be understood that references to the width of portions of the hull of the vessel are references to the width of the respective portion in a direction laterally and perpendicular to the longitudinal axis of the hull at the widest point of the portion.

5 The hull of the vessel may have any suitable dimensions of length, width and height. It is an advantage of the hull configuration of the present invention that the hull may be applied on a wide range of different scales, according to need.

10 The bow, central and stern portion of the hull of the vessel may be of any suitable length, relative to each other. In a preferred embodiment, the bow portion comprises at least 10.0% of the total length of the hull of the vessel, more preferably 15.0%, still more preferably 20.0% of the total length. In one particularly preferred embodiment, the bow portion comprises about 25.0% of the total length of the hull of the vessel.

15 Similarly, the stern portion comprises at least 10.0% of the total length of the hull of the vessel, more preferably 15.0%, still more preferably 20.0% of the total length. In one particularly preferred embodiment, the bow portion comprises about 25.0% of the total length of the hull of the vessel.

20 The length of the bow and stern portions may be the same or different. Preferably, the bow portion and the stern portion have the same length.

25 The central portion of the hull preferably comprises less than 80.0% of the total length of the hull of the vessel, more preferably 70.0%, still more preferably 60.0% of the total length. In one particularly preferred embodiment, the central portion of the hull comprises about 50.0% of the total length of the hull of the vessel.

30 As noted, the bow portion and the stern portion may be the same in size and form, or may be different in either form and/or size, for example length and/or width. In one preferred arrangement, the bow and stern portions have the same form and are generally of the same size.

The transition between each of the bow and stern portions of the hull and the central portion of the hull is preferably smooth.

To further increase the tendency of the vessel to pitch and roll, the hull of the vessel is preferably without other features commonly provided in the design of conventional water-borne vessels to provide the vessel with increased stability. For example, the hull of the vessel is preferably provided with a rounded bilge. Further, it is preferred that the hull is not provided with a substantial keel, as a keel acts to dampen the rolling motion of the hull. Preferably, the hull is not provided with a keel extending from the bottom of the hull. Still further, the hull is preferably not provided with rubbing strakes.

The vessel of the present invention may comprise a single hull, that is be of a mono-hull configuration. Alternatively, the vessel may comprise two or more hulls of the aforescribed configuration, for example a catamaran or a trimaran. Preferably, the vessel is a mono-hull configuration.

To propel the vessel across the water, the vessel is provided with one or more foil assemblies. The foil assemblies are arranged such that vertical motion of the foil assemblies with respect to the water generates forward thrust on the foil assemblies and, hence, movement through the water of the vessel to which they are attached.

The foil assemblies each comprise one or more foils, movement of which through the water induces thrust to propel the vessel. The foil assemblies may be located at any suitable position on the hull of the vessel. For example, the or each foil assembly may be mounted on a boom or arm assembly extending from the hull, for extending longitudinally from the bow or the stern of the hull and/or laterally to one side of the hull. More preferably, the or each foil assembly extends directly from the hull. In this way, the or each foil assembly is less vulnerable to damage.

Suitable foil assemblies are known in the art. In particular, preferred foil assemblies are those comprising one or more foils that are deformed under the action of movement of the foil relative to the water, such that the foil assumes an

hydrofoil form, thereby generating thrust on the hull of the vessel to move the vessel through the water.

5 An improved foil assembly providing increased propulsion to a vessel and having improved robustness has now been found.

Accordingly, in a further aspect, the present invention provides a foil assembly for a wave-powered, water-borne craft, the foil assembly comprising:

10 a substantially rigid leading edge assembly having a first end and a second end;

a flexible foil extending from the leading edge assembly, the flexible foil having an inner edge and a trailing edge; and

15 a tensioning assembly for tensioning the flexible foil, the tensioning assembly applying a tension to the flexible foil in the direction away from the leading edge assembly and towards the trailing edge of the flexible foil, the tension be provided to the flexible foil at an angle between the inner edge and the trailing edge of the flexible foil.

20 The foil assembly comprises a leading edge assembly, from which a flexible foil extends. The leading edge assembly is substantially rigid in comparison with the flexible foil, such that the foil may flex in relation to the leading edge assembly with substantially no flexing of the leading edge assembly. In use, the foil assembly is mounted to the hull of the vessel such that the leading edge assembly of the foil assembly is presented to the water, that is the leading edge is forwardmost, and the
25 flexible foil extends rearwards from the leading edge assembly. The flexible foil has an inner edge and a trailing edge. The foil assembly is arranged such that the flexible foil is tensioned, with the tension being applied to the flexible foil at an angle between the inner edge and the trailing edge.

30 Typically, the foil assembly is mounted to the hull, either directly to the hull or relative to the hull by means of a mounting assembly, such that movement of the foil assembly through the water induces movement of the hull. Accordingly, the foil assembly is generally mounted to the hull to generate forward motion to the hull. As

a result, the foil assembly is mounted with the leading edge assembly forwardmost and extending generally laterally of the longitudinal axis of the hull.

The leading edge assembly may have any suitable form. The leading edge
5 assembly supports the foil and assists in providing and maintaining the necessary
tension to the foil. The leading edge assembly may solely provide a support function,
that is to support the flexible foil. More preferably, the leading edge assembly is
shaped to provide thrust under the action of moving through the water. In one
preferred embodiment, the leading edge assembly is in the form of a hydrofoil. The
10 hydrofoil is preferably a symmetrical hydrofoil, that is without camber and has
symmetrical top and bottom surfaces. Suitable hydrofoil forms are known in the art.
One preferred general form for the foil is a NACA form, known in the art of airfoil
design, in particular a foil in the NACA four digit series. As noted above, preferred
NACA foils are those without camber, that is the NACA 00 series of foils. Preferably,
15 the hydrofoil has a thickness-to-chord ratio of from 10 to 20%, more preferably from
12 to 15. A particularly preferred general form for the leading edge assembly is a
NACA 0012 to 0015 hydrofoil.

The leading edge assembly may be of any suitable size to support the
20 required area of foil. Preferably, the leading edge assembly comprises from 10 to
20% of the width of the foil assembly, that is the distance from the leading edge to
the trailing edge, more preferably about 15%.

The foil assembly is mounted to the hull of a vessel at a first end of the
25 leading edge assembly, with the second end of the leading edge assembly being
distal from the hull. The first end of the leading edge assembly is at or generally
towards the longitudinal axis of the hull of the vessel, while the second end of the
leading edge assembly is generally away from the longitudinal axis of the hull. As
noted above, the foil assembly may be mounted directly to the hull of the vessel.
30 Alternatively, the foil assembly may be provided with a support assembly extending
from the vessel and to which the foil assembly is mounted. References herein to the
foil assembly or parts thereof being mounted to the hull are to be understood
accordingly as including mounting via such a support assembly.

The foil assembly may be rigidly mounted with respect to the hull, that is the leading edge assembly is at a fixed position and orientation with respect to the hull. Alternatively, the foil assembly may be mounted such that the leading edge assembly may be rotatable with respect to the hull, that is the leading edge assembly is able to rotate about its mounting with respect to the vessel hull. Preferably, the leading edge assembly is mounted so as to be rotatable about a longitudinal axis of the leading edge assembly with respect to the hull. In one arrangement, the leading edge assembly is rotatable about an axle extending from the mount of the foil assembly and extending within the first end portion of the leading edge assembly, with the leading edge assembly able to rotate about the axle. Means may be provided to limit the rotation of the leading edge assembly with respect to the hull, in particular to limit the leading edge assembly to rotation through a particular arc. In one embodiment, rotation of the leading edge assembly with respect to the hull is limited by the tension applied to the flexible foil, with the leading edge assembly otherwise free to rotate without limitation.

The leading edge assembly may be uniform in cross-section along its length. More preferably, the leading edge assembly is tapered, being wider in at least one dimension at the first end adjacent or towards the longitudinal axis of the vessel hull than at the second end distal therefrom. Preferably, the width of the leading edge assembly in the direction from the leading edge to the trailing edge at the first end is greater than the width at the second, distal end. In one preferred embodiment, the ratio of the width of the leading edge assembly at the first end to the second end is from 2.0, more preferably at least 2.5, still more preferably at least 3.0.

The second end of the leading edge assembly is preferably rounded. A particularly preferred arrangement has the leading edge assembly tapering from the first end to the second end, with the second end being rounded.

The leading edge assembly may be straight, that is extend with a straight longitudinal axis away from the longitudinal axis of the hull of the vessel. The leading edge assembly may extend substantially perpendicular to the longitudinal axis of the hull or be raked at an angle thereto, preferably extending outwards and rearwards of the vessel longitudinal axis. More preferably, the leading edge assembly extends

outwards from the longitudinal axis of the hull in an arc, in particular in an arc extending rearwards away from the leading edge. The arc may be selected according to such factors as to prevent entanglement of the foil assembly with lines or objects in the water. The arc of the leading edge assembly may be variable, for
5 example by having the leading edge assembly flexed under an applied tensioning force.

The leading edge assembly may be formed from any suitable materials, sufficient to withstand the forces exerted thereon by the incident waves and the
10 motion of the vessel. Suitable materials include wood, for example laminated wood, metals, including alloys, especially lightweight metals and alloys, for example aluminium and alloys thereof, and plastics, in particular fibre reinforced plastics, such as plastics reinforced with glass or carbon fibres and the like.

15 The foil assembly further comprises a flexible foil extending from the leading edge assembly. The foil is a flexible membrane and has an inner edge adjacent or towards the longitudinal axis of the hull and a trailing edge.

The inner edge extends from the leading edge assembly to the trailing edge
20 of the flexible foil and is the edge at or towards the longitudinal axis of the hull of the vessel. The inner edge of the flexible foil is preferably straight or substantially straight. It is preferred that the inner edge of the flexible foil is arranged to be substantially parallel to the longitudinal axis of the hull of the vessel. However, the inner edge may extend at an angle to the longitudinal axis. If the inner edge extends
25 at an angle to the longitudinal axis of the hull, it is preferred that the angle is kept to a minimum, preferably less than 20°, still more preferably less than 15°, more preferably still less than 10° to the longitudinal axis of the hull.

The trailing edge is the rearmost edge of the flexible foil and typically extends
30 laterally outwards away from the longitudinal axis of the hull. In one embodiment, the trailing edge extends generally perpendicular to the longitudinal axis of the hull. The trailing edge of the flexible foil may be straight or substantially straight. In one embodiment, the trailing edge is curved and extends in an arc outwards from the

longitudinal axis of the hull. Preferably, a curved trailing edge extends in an arc outwards and forwards from the longitudinal axis.

5 The foil may have any suitable shape. A particularly preferred shape is generally triangular, with the inner edge and trailing edge of the foil and the leading edge assembly forming the sides of the triangle. In this arrangement, the trailing edge of the flexible foil extends from the inner edge to the leading edge assembly, preferably to the second end of the leading edge assembly.

10 The foil is tensioned under the action of the tensioning assembly. As noted above, the tensioning assembly applies tension, that is a force, to the foil at an angle between the inner edge and the trailing edge of the foil. The applied tension is a force acting away from the leading edge assembly and towards the trailing edge of the flexible foil. The tension applied to the flexible foil may be at any angle between
15 the inner edge and the trailing edge of the flexible foil. Preferably, the tensioning force is applied in a direction that bisects the angle between the inner edge and the trailing edge of the flexible foil.

The force applied by the tensioning assembly to tension the flexible foil is at
20 an angle to the longitudinal axis of the hull of the vessel. In particular, the force is applied to the flexible foil at an acute angle to the forward direction of the longitudinal axis. The force may be applied at any suitable angle that evenly tensions the flexible foil. The force applied and the angle are such that the flexible foil presents the optimum angle of attack to the moving water when moving both upwards and
25 downwards through the water, thereby optimising the thrust produced by the foil assembly. The tensioning force may be applied to the flexible foil at an angle of from 5 to 80° to the longitudinal axis of the hull, more preferably from 10 to 70°, still more preferably from 10 to 60°. An angle in the range of from 10 to 40° to the longitudinal axis is particularly preferred for many embodiments. The angle of the tensioning
30 force will vary according to the particular shape of the flexible foil, in particular if the tensioning force is to be applied at an angle to bisect the angle between the inner edge and the trailing edge of the flexible foil, as in the preferred arrangement.

The angle of incidence of the foil assembly, in particular the leading edge assembly of the foil assembly is selected to produce forward thrust of the foil assembly to propel the vessel. The angle of incidence may be adjusted, for example, by adjusting the tension applied to the flexible foil by the tensioning assembly.

5

Suitable materials for forming the foil are known in the art and include any flexible, pliable or elastic materials. Examples of suitable materials include rubber, for example sheets of natural or synthetic rubber, polymer sheets, for example sheets of polyurethane, polyvinylchloride and polyolefins, and thermoplastic elastomers. The foil may be formed by weaving yarns of one or more suitable materials. Alternatively, the foil may be formed by casting, for example. Other techniques for forming the foil are known in the art. In one embodiment, the material of the flexible foil is elastic.

10

15

The material of the foil and its properties should be selected to ensure that the foil is able to form a hydrofoil shape upon movement through the water, both upwards and downwards. Further, the material should be resistant to extended immersion in water, in particular sea water, and resistant to prolonged exposure to light, in particular ultraviolet (UV) light.

20

The tensioning assembly may comprise any suitable means for applying tension to the flexible foil in the manner hereinbefore described. Suitable means for applying the required tension to the foil include a tensioning member attached at one end to the flexible foil, in particular to the region of the flexible foil adjacent the intersection of the inner edge and the trailing edge. The other end of the tensioning member is secured to the hull or the support assembly holding the foil assembly. The tensioning member is placed under tension, which in turn tensions the material of the foil. In one embodiment, the tensioning member is a line.

25

30

The tensioning assembly may comprise an elastic component, such that the tension applied to the flexible foil is elastic. In one embodiment, the tensioning assembly comprises a tensioning member, arranged as described above, the tensioning member being elastic or having an elastic component therein. For

example, the tensioning member may be an elastic line. Alternatively, the tensioning member may comprise or be connected to a resilient member, such as a spring.

The tensioning assembly may apply a fixed tension to the flexible foil.

5 Alternatively, and more preferably, the tensioning assembly is adjustable, such that the tension applied to the foil may be varied. In this way, the form of the foil assembly in the water may be adjusted to balance the forces created by the movement of the hull of the vessel with respect to the water and to optimise the drive generated by the foil assembly. This will vary according to such factors as the weight
10 of the vessel, or the amount of any ballast or payload being carried by the vessel.

As noted above, the leading edge assembly is rigid, that is rigid in relation to the foil, which is flexible and able to move under action of movement upwards and downwards through the water, so as to adopt a hydrofoil shape, thereby inducing
15 thrust on the hull of the vessel. The leading edge assembly may have some inherent flexibility, in particular resiliency, allowing the leading edge assembly to flex under the action of the tensioning force applied to the foil by the tensioning assembly. This can assist in maintaining a uniform tension on the flexible foil.

20 The foil assembly may have any suitable ratio of the length of the foil assembly to the width of the foil assembly at its widest point. In this respect, the length of the foil assembly is the distance from the first end to the second end of the leading edge assembly and the width is the distance from the leading edge to the trailing edge of the assembly. The aspect ratio is preferably in the range of from 2.0
25 to 10.0, more preferably from 2.5 to 8.0, still more preferably from 3.0 to 7.5. More preferably still, the aspect ratio of the foil assembly is from 3.5 to 7.0, in particular from 4.0 to 6.0, especially from 4.5 to 5.5. An aspect ratio of about 5.0 has been found to be particularly advantageous in many embodiments.

30 To allow for adjustment of the area of the foil assembly, as discussed below, means may be provided to vary the area of the flexible foil between the leading edge assembly and the trailing edge of the foil. For example, the flexible foil may be arranged to be rolled and unrolled about, the leading edge assembly or a portion thereof.

As noted above, the vessel is provided with at least one, more preferably a plurality of foil assemblies. Preferably, some or, more preferably all, of the foil assemblies are of the aspect of the present invention hereinbefore described. The total area of the foil assemblies may be expressed as a percentage of the total area of the horizontal cross-section of the hull of the vessel at the waterline. The total area of the foil assemblies is preferably from 10 to 40% of the total waterplane area of the vessel, that is the horizontal cross-sectional area at the waterline of the vessel. More preferably, the total area of the foil assemblies is from 15 to 30% of the total waterline area of the vessel.

The position of the waterline on the hull of the vessel will vary in use, for example according to the ballasting and payload of the vessel. The weight and position of the ballast of the vessel will vary the periods of pitching and rolling of the vessel under the action of incident waves. Accordingly, it is preferred that the total surface area of the foil assemblies in the water is variable, to accommodate changes in the periods of pitching and rolling of the vessel.

Further, it may be necessary to vary the total surface area of the foil assemblies according to the prevailing weather conditions, in particular the size and nature of the incident waves. In particular, in order to avoid damage to the vessel in particularly heavy weather conditions, it is preferred that the foil assemblies allow the foils to be reefed, as noted above, and/or fully retracted and stowed. If retractable, the foil assemblies are preferably retractable and stowed above the water line and out of the water. The ability to raise the foil assemblies from the water is also an advantage for vessels that are required to enter a harbour or port and to be docked.

The vessel may be provided with any suitable number and configuration of foil assemblies, as required to provide the required propulsion of the vessel. Preferably, the vessel comprises a plurality of foil assemblies, in particular at least two foil assemblies. The foil assemblies may have the same surface area or a different surface area. The foil assemblies may be in any suitable arrangement on the vessel.

Preferably, the foil assemblies are arranged to be symmetrical about the longitudinal axis of the vessel, that is the foil surface area is arranged in a symmetrical manner about the longitudinal axis. In this way, the rolling motion of the vessel about its longitudinal axis is balanced.

5

The foil assemblies are preferably arranged symmetrically about the lateral longitudinal axis of the vessel, that is the foil surface area forward of the mid-point of the vessel is the same as the foil surface area aft of the vessel mid-point. In this way, pitching motion of the vessel about its mid-point is balanced.

10

The foil assemblies are preferably arranged to have surface area of the foil displaced from the longitudinal axis of the vessel. In one arrangement, the foil assemblies are displaced from the longitudinal axis. In this way, the rolling motion of the vessel is more efficiently converted by the foil assemblies into motion of the vessel.

15

In one embodiment, the vessel comprises first and second foil assemblies, with the first foil assembly mounted at or adjacent the bow of the vessel and the second foil assembly mounted at or adjacent the stern of the vessel.

20

In an alternative embodiment, the vessel comprises a single foil assembly at or adjacent the bow and two foil assemblies at or adjacent the stern of the vessel. The foil assemblies are sized to balance both pitching of the vessel fore and aft and to balance rolling of the vessel from side to side.

25

The foil assemblies are arranged to have the foils submerged below the water surface. The foil assemblies may be arranged to lie within the footprint of the vessel hull. Alternatively, part or all of the surface area of the foil assembly may extend from or lie outside the area of the hull at the waterline. In particular, the part or all of the foil assembly may extend beyond the bow or stern of the vessel or laterally from the hull.

30

As indicated above, each foil assembly may be mounted directly to the hull of the vessel. Alternatively, the vessel may be provided with a foil support assembly extending from the hull and supporting one or more foil assemblies. It is advantageous to have the position of the foil assemblies variable, in particular to be able to vary the position of the or each foil assembly along the longitudinal axis of the hull of the vessel, that is forwards or rearwards along the vessel, laterally of the hull of the vessel, and/or adjusting the height of the foil assemblies relative to the water. In this way, the action of the or each foil assembly may be optimised for such factors as the prevailing conditions and the condition of the vessel, for example its payload or ballast. Means for effecting such adjustment of the position of the foil assemblies is particularly preferred for manned vessels.

As noted above, the action of the incident waves on the hull of the vessel causes the vessel to pitch and roll. The form of the vessel hull of the present invention is designed to enhance the pitching and rolling motion induced by the action of incident waves, as described above. This movement of the hull, and hence the foil assemblies, relative to the water causes the foil assemblies to generate motion of the hull through the water. The pitching and rolling motion of the hull may be increased or decreased by varying the weight and position of ballast within the hull. In particular, the pitching of the hull is varied by moving the ballast along the length of the vessel. The rolling action of the hull may be varied by altering the vertical position of the ballast in the hull.

In one preferred embodiment, the vessel comprises a ballast and means for varying the position of the ballast within the hull. In this way, the vessel may be adjusted to accommodate different wave conditions. In addition, by having the position of the ballast variable in this way, the vessel may be adapted to different payloads, while remaining optimised as far as possible to generate motion of the vessel through the water under the action of the foil assemblies.

30

The vessel may also comprise means to move the vessel, in particular to rock the vessel about the longitudinal axis of the hull and/or to pitch the vessel forward and aft about the lateral midline of the hull. This rocking and/or pitching motion of the vessel causes the foil assemblies to move through the water, in turn generating

thrust on the vessel and propelling it through the water. In this way, the vessel may be propelled using the foil assemblies when in calm water with insufficient or no waves. Suitable means for rocking and/or pitching the vessel include one or more electrical generators or a pendulum assembly.

5

Further, the vessel may be provided with means to move the or each foil upwards or downwards through the water, again to generate thrust to propel the vessel in the case of calm water with insufficient or no waves.

10

In one embodiment, the vessel of the present invention is unmanned and carries an array of sensors, for example to measure one or more parameters of the environment of the vessel, together with means for transmitting and receiving data.

15

Embodiments of the foil assembly and vessel of the present invention will now be described, by way of example only, having reference to the accompanying drawings, in which:

20

Figure 1 is a perspective view of a vessel hull according to one embodiment of the present invention;

Figure 2 is a plan view of the hull of Figure 1 in the direction of arrow II in Figure 1;

25

Figure 3 is a side view of the hull of Figure 1 in the direction of arrow III in Figure 1;

Figure 4 is a frontal view of the hull of Figure 1 from the bow in the direction of arrow IV in Figure 1;

30

Figure 5a is plan view of a foil assembly according to one embodiment of the present invention;

Figure 5b is a side view of the foil assembly of Figure 5a;

Figure 6 is a side view of an alternative foil assembly to that of Figures 5a and 5b; and

Figure 7 is a plan view of a vessel according to the present invention
5 comprising a hull of the embodiment of Figures 1 to 4 and a foil assembly of Figure 5.

10 Referring to Figure 1, there is shown a perspective view of a hull of a vessel according to one embodiment of the present invention. The hull, generally indicated as 2, is shown with lines corresponding to the contours of the hull to indicate the general form of the hull. The hull is shown in plan view in Figure 2, in side elevational view in Figure 3 and in a front view from the bow in Figure 4, again with
15 contour lines present to indicate the shape of the hull, as appropriate.

The hull 2 is shown in the figures in the orientation in which it sits in the water and the use of such terms as 'upper' and 'lower' are to be understood accordingly. Similarly, the term 'rearwards' is indicating a direction away from the bow and
20 towards the stern of the hull, while the term 'forwards' is an indication in the opposite direction, that is towards the bow and away from the stern.

The hull has a generally smooth outer surface. The major features of the shape of the hull are described below. It is to be understood that the transition from
25 one feature to another is generally smooth, unless otherwise indicated.

The hull 2 comprises a central portion 4, a bow 6, a bow portion 8 extending between the bow and the central portion, a stern 10, and a stern portion 12 extending between the stern and the central portion. The hull 2 is symmetrical about both its
30 longitudinal axis 14 and its central lateral axis 16. As a result, the bow portion 8 and the stern portion 12 are the same in form and size. Accordingly, the forward half of the hull 2, extending from the lateral axis 16 to the bow 6 will be described in detail. It is to be understood that the form of the rear portion extending from the lateral axis 16 to the stern is the same.

The hull has an upper edge or deck 20 and a lower edge or keel 22. The keel does not extend from the bottom of the hull, so as to provide a smooth bottom surface with minimal resistance to movement through and with respect to the water.

5

The bow 6 is provided with an upper rake 24, extending upwards and rearwards from the bow 6, and a lower rake 26, extending downwards and rearwards from the bow. The upper rake 24 is generally convex in form and transitions in a smooth curve to the deck 20. The lower rake 26 is substantially linear and meets the keel 22 at an angle. The rakes 24, 26 of the bow reduce the tendency for the bow to become entangled with lines, debris or the like below the waterline and to minimise windage and wetted area above the waterline. A straight bow would also function efficiently to cut through and enter the waves.

10

15

The bow portion 8 has generally planar opposing sides 30, 32 extending from the deck 20 to the keel 22. The bow portion 8 is viewed in plan view in Figure 2 and can be seen to be tapered and increase in width extending rearwards from the bow 6. In plan view, the bow portion is substantially triangular, with the base of the triangle extending laterally across the hull and the sides extending substantially straight in the rearwards direction. A more concave form may be provided to the sides of the triangle if desired.

20

25

The contours of the bow portion may also be seen in a vertical view in Figure 4 and can be seen to taper inwards in the vertical direction extending from the deck 20 to the keel 22.

The form of the bow portion 8 is to allow it to cut into and through waves that are incident on the hull 2 and to prevent the bow portion from rising upwards or falling downwards under the action of the incident wave.

30

The central portion 4 has a flared region 40. The flared region 40 provides a transition between the bow portion 8 and the central portion 4. The flared portion 40 tapers laterally outwards in the rearwards direction and has opposing sides 42, 44 of a generally concave form. Referring to Figure 3, the flared region 40 has an upper

flared portion 46 and a lower portion 48. The upper flared portion 46 has a greater width than the lower portion 48 and is arranged to be above the normal waterline of the hull 2. A transitional surface 50 lies between the upper flared portion 46 and the lower portion 48 and extends rearwards and downwards to the keel 22 at a point 52.

5

The central portion 4 to the rear of the flared region and the point 52 has a generally rounded, bulbous shape extending to the central lateral axis 16, where the central portion is at its widest. As shown in Figure 4, the central portion has opposing outer surfaces 60, 62 which extend substantially vertically between the deck 20 and keel 22.

10

In operation, a wave is incident at the bow 6 of the vessel. The form of the bow portion 8 causes the bow portion to cut into and enter the wave with little or no action of the wave lifting the bow 6. The wave contacts the flared region 40 of the central portion, in particular the surfaces 42 and 44. The wave contacts the transitional surface 50 and the flared upper portion 46 of the flared region 40. This action causes the hull to be lifted at the flared region 40. In cases where the incident wave is symmetrical on both sides of the hull 2, the lift on the upper portions 46 of each side of the flared surface is substantially the same, causing the hull to pitch. In cases where the incident wave is asymmetrical to the hull, the action of the wave contacting the flared region 40 is a combined pitching and rolling motion of the hull.

15

20

The upper flared portions 46 of the flared regions of the central portion 4 may extend from the central portion along the upper portion of the rearmost part of the bow portion 8. In this way, the interaction between the incident wave and the flared regions 40 may occur soon in the passage of the wave along the hull of the vessel, in turn increasing and/or accelerating the lifting action of the hull to so to increase the induced pitching motion.

25

30

The hull of Figures 1 to 4 may be used with a variety of different foil assemblies. The degree of pitching and rolling induced by the shape and form of the hull interacting with the water of an incident wave causes the foil assemblies to move through vertically through the water, in turn generating thrust and causing the vessel

to move through the water. A preferred foil assembly is shown in Figures 5a and 5b and described in detail below.

Referring to Figures 5a and 5b, there is shown a foil assembly for use in
5 propelling a water borne vessel under the action of incident waves. The foil assembly, generally indicated as 102, comprises a leading edge assembly, generally indicated as 104, and a flexible foil, generally indicated as 106.

The leading edge assembly 104 has a first end 110 and a generally rounded
10 second end 112. The foil assembly is mounted to a vessel and arranged such that the first end 110 is adjacent or towards the longitudinal axis of the hull of the vessel and the second end 112 is distal thereof.

The leading edge assembly 104 comprises a stiff, generally tubular leading
15 edge member 120 formed from glass fibre reinforced plastic. The leading edge member 120 has the profile of a hydrofoil, in particular the general form of a NACA 0012 to 0015 foil, with a leading edge 122 generally facing the intended direction of travel of the vessel. The leading edge member 120 is generally arcuate, being curved rearwards, that is away from the leading edge 122, in moving from the first
20 end 110 to the second end 112.

The foil assembly 2 is mounted to the vessel, either directly to the hull or to a foil support assembly, by means of a mounting shaft or spar 124 extending into the leading edge member 120 from the first end. The leading edge member 120 may be
25 fixed in relation to the mounting shaft or spar 124 or may be rotatably mounted on the shaft.

The flexible foil 106 comprises a generally triangular sheet of polyurethane. The foil 106 has a leading edge portion 130 attached to the leading edge member
30 120, for example by a suitable adhesive. The foil 106 further has an inner edge 132 extending rearwards from the first end 110 of the leading edge assembly 104 and a trailing edge 134. The trailing edge 134 extends from the rearmost end of the inner edge to the second end 112 of the leading edge assembly 104.

The foil assembly 102 is mounted to the vessel so as to have the inner edge 132 of the foil 106 extending substantially parallel to the longitudinal axis of the hull of the vessel.

5 A tensioning assembly, generally indicated as 140, comprises a tensioning member in the form of a line 142 attached to an eyelet ring 144 in the portion of the foil 106 adjacent the intersection of the inner edge 132 and the trailing edge 134. The line 142 is attached either to the hull of the vessel or a suitable support assembly (not shown for clarity) and tensioned, thereby applying a tension to the foil 106. As
10 shown in Figure 5a, the line 142 extends at an angle to both the inner edge 132 and the trailing edge 134 of the foil 106, thereby applying a tensioning force to the foil. The tensioning force is applied to the foil 106 by the line at an angle that substantially bisects the angle between the inner edge 132 and the trailing edge 134.

15 The line 142 may be elastic or comprise a portion that is elastic.

Turning to Figure 6, there is shown an alternative configuration for the foil assembly. Components common to the embodiments of Figures 5a, 5b and Figure 6 are indicated using the same reference numerals. In the embodiment of Figure 6,
20 the foil 106 is formed of two plies of material, 106a, 106b, and extends around the leading edge member 120, as shown.

Finally, referring to Figure 7, there is shown a plan view of a wave-powered, water-borne vessel, generally indicated as 202, comprising a hull 204 according to
25 the embodiment of the present invention shown in Figures 1 to 4 and described above. The vessel 202 further comprises four foil assemblies 206a, 206b, 206c, 206d, according to the embodiment of Figures 5a and 5b, and described above. The foil assemblies are arranged in pairs, with a two foil assemblies 206a, 206b arranged on opposing sides of the bow portion 208 of the hull and two foil assemblies 206c,
30 206d arranged on opposing sides of the stern portion 210 of the hull 204. The foil assemblies are shown mounted directly to the hull 202, by means of spars, as described above in relation to Figure 5a. The foil assemblies 206a to 206d are positioned to be below the normal waterline of the vessel, so as to remain submerged throughout substantially the entire motion of the vessel. The action of the

incident waves causing the hull to pitch and roll, as described above, causes the foil assemblies to rise and fall through the water, in turn inducing thrust to drive the hull forwards through the water, that is in the direction to the left in Figure 7.

CLAIMS

- 5 1. A water-borne vessel for propulsion by incident waves, the vessel comprising a hull, the hull of the vessel comprising:
- an elongate bow portion having a length greater than its width at its widest point;
- an elongate stern portion having a length greater than its width at its widest
- 10 point; and
- a central portion between the bow portion and a stern portion, the central portion having a width greater than the widths of the bow and stern portions, the central portion comprising a first flared region at the junction with the bow portion, the first flared portion having a width greater than the width of the adjacent region of the
- 15 bow portion, and a second flared region at the junction with the stern portion, the second flared region having a width greater than the width of the adjacent region of the stern portion, the central portion having its widest point between the first and second flared regions and greater than the widths of the first and second flared regions;
- 20 wherein the bow and stern portions act to cut through an incident wave; and
- wherein the central portion acts to induce the hull to pitch and roll under the action of an incident wave;
- the vessel further comprising a foil assembly for generating movement of the vessel through the water under the action of an incident wave.
- 25
2. The vessel according to claim 1, wherein the bow portion and the stern portion are of the same form.
3. The vessel according to either of claims 1 or 2, wherein the bow
- 30 portion and the stern portion are substantially of the same length.
4. The vessel according to any preceding claim, wherein the bow portion and/or the stern portion has substantially flat, planar sides extending from the upper edge to the lower edge of the hull.

5. The vessel according to any preceding claim, wherein the bow portion and/or the stern portion is tapered and increases in width along the longitudinal axis of the hull in the direction towards to the centre of the hull.

5

6. The vessel according to any preceding claim, wherein the bow portion and/or the stern portion is tapered in the vertical direction, the portion increase in width in the direction from the lower edge of the hull to the upper edge of the hull.

10

7. The vessel according to any preceding claim, wherein the ratio X of the length of the bow portion to the width of the bow portion at its widest point is at least 2.5.

15

8. The vessel according to any preceding claim, wherein the ratio Y of the length of the stern portion to the width of the stern portion at its widest point is at least 2.5.

20

9. The vessel according to any preceding claim, wherein one or both of the first and second flared regions has an upper portion and a lower portion, the width of the upper portion being lower than the width of the lower portion.

10. The vessel according to claim 9, wherein the upper portion is above the normal waterline of the hull when in use.

25

11. The vessel according to either of claims 9 or 10, wherein the ratio of the width of the upper portion to the width of the lower portion is at least 1.2.

30

12. The vessel according to either of claims 10 or 11, wherein one or both of the first and second flared regions comprises a transitional surface between the upper portion and the lower portion.

13. The vessel according to claim 12, wherein the transitional surface extends at an angle downwards and towards the centre of the central portion.

14. The vessel according to any preceding claim, wherein one or both of the first and second flared regions comprises at least 10% of the length of the central portion.

5 15. The vessel according to any preceding claim, wherein one or both of the first and second flared regions extends into the respective bow and/or stern portion.

10 16. The vessel according to any preceding claim, wherein the central portion has a ratio Z or its length to its width that is no greater than 8.0.

15 17. The vessel according to any preceding claim, wherein the width of the central portion at its widest point to the maximum width of the bow or stern portion is at least 2.0.

18. The vessel according to any preceding claim, wherein the bow and/or the stern portion comprises at least 10.0% of the length of the hull.

20 19. The vessel according to any preceding claim, wherein the central portion comprises less than 80.0 % of the length of the hull.

20. A foil assembly for a wave-powered, water-borne craft, the foil assembly comprising:

25 a substantially rigid leading edge assembly having a first end and a second end;

a flexible foil extending from the leading edge assembly, the flexible foil having an inner edge and a trailing edge; and

30 a tensioning assembly for tensioning the flexible foil, the tensioning assembly applying a tension to the flexible foil in the direction away from the leading edge assembly and towards the trailing edge of the flexible foil, the tension be provided to the flexible foil at an angle between the inner edge and the trailing edge of the flexible foil.

21. The assembly according to claim 20, wherein the leading edge assembly is shaped to provide thrust to the vessel under the action of moving through the water.

5 22. The assembly according to claim 21, wherein the leading edge assembly is a hydrofoil.

23. The assembly according to claim 22, wherein the leading edge assembly has the form of a foil from the NACA 00 series.

10

24. The assembly according to claim 23, wherein the leading edge assembly has the form of a NACA 0012 to 0015 foil.

15 25. The assembly according to any of claims 20 to 24, wherein the leading edge assembly is from 10 to 20% of the width of the foil assembly.

26. The assembly according to any of claims 20 to 25, wherein the foil assembly is mounted such that the leading edge assembly is rotatable about its longitudinal axis with respect to the hull of the vessel.

20

27. The assembly according to claim 26, wherein the foil assembly comprises an axle extending into a first end of the leading edge assembly, the leading edge assembly being rotatable about the axle.

25 28. The assembly according to either of claims 26 or 27, wherein rotation of the foil assembly is limited by the tension applied to the flexible foil by the tensioning assembly.

30 29. The assembly according to any of claims 20 to 28, wherein the leading edge assembly tapers and is wider at a first end towards the longitudinal axis of the vessel than at a second end distal from the longitudinal axis of the vessel.

30. The assembly according to claim 29, wherein the ratio of the width of the leading edge assembly at the first end to the width at the second end is at least 2.0.

5 31. The assembly according to any of claims 20 to 30, wherein the leading edge assembly extends in an arc.

32. The assembly according to claim 31, wherein the leading edge assembly extends in an arc outwards and rearwards of the hull of the vessel.

10

33. The assembly according to claim 32, wherein the arc is variable.

34. The assembly according to any of claims 20 to 33, wherein the inner edge of the flexible foil is substantially straight.

15

35. The assembly according to claim 34, wherein the inner edge is substantially parallel to the longitudinal axis of the hull.

20 36. The assembly according to any of claims 20 to 35, wherein the trailing edge of the flexible foil extends in an arc outwards and forwards with respect to the longitudinal axis of the hull.

37. The assembly according to any of claims 20 to 36, wherein the flexible foil is substantially triangular.

25

38. The assembly according to any of claims 20 to 37, wherein the tensioning force at an angle of from 5 to 80° to the forward direction of the longitudinal axis of the hull.

30 39. The assembly according to any of claims 20 to 38, wherein the tensioning force is applied to the flexible foil at an angle to bisect the angle between the inner edge and trailing edge.

40. The assembly according to any of claims 20 to 39, wherein the tensioning assembly comprises an elastic component.

5 41. The assembly according to any of claims 20 to 40, wherein the tensioning assembly comprises a line connected at one end to the region of the flexible foil adjacent the intersection of the inner edge and trailing edge.

42. The assembly according to any of claims 20 to 41, wherein the tension applied by the tensioning assembly is variable.

10

43. The assembly according to any of claims 20 to 42, wherein the ratio of the length of the foil to the width of the foil is from 2.0 to 10.0.

15 44. The assembly according to any of claims 20 to 43, wherein the area of the flexible foil is adjustable.

45. The vessel according to any of claims 1 to 19 comprising a foil assembly according to any of claims 20 to 44.

20 46. The vessel according to claim 45, wherein the vessel comprises a plurality of foil assemblies, the foil assemblies being arranged such that the surface area of the foil assemblies is symmetrical about the mid-point of the vessel hull.

25 47. The vessel according to either of claims 45 or 46, wherein the vessel further comprises means to move the or each foil assembly vertically through the water.

48. The vessel according to any of claims 45 to 47, wherein the or each foil assembly is displaced from the longitudinal axis of the hull of the vessel.

30

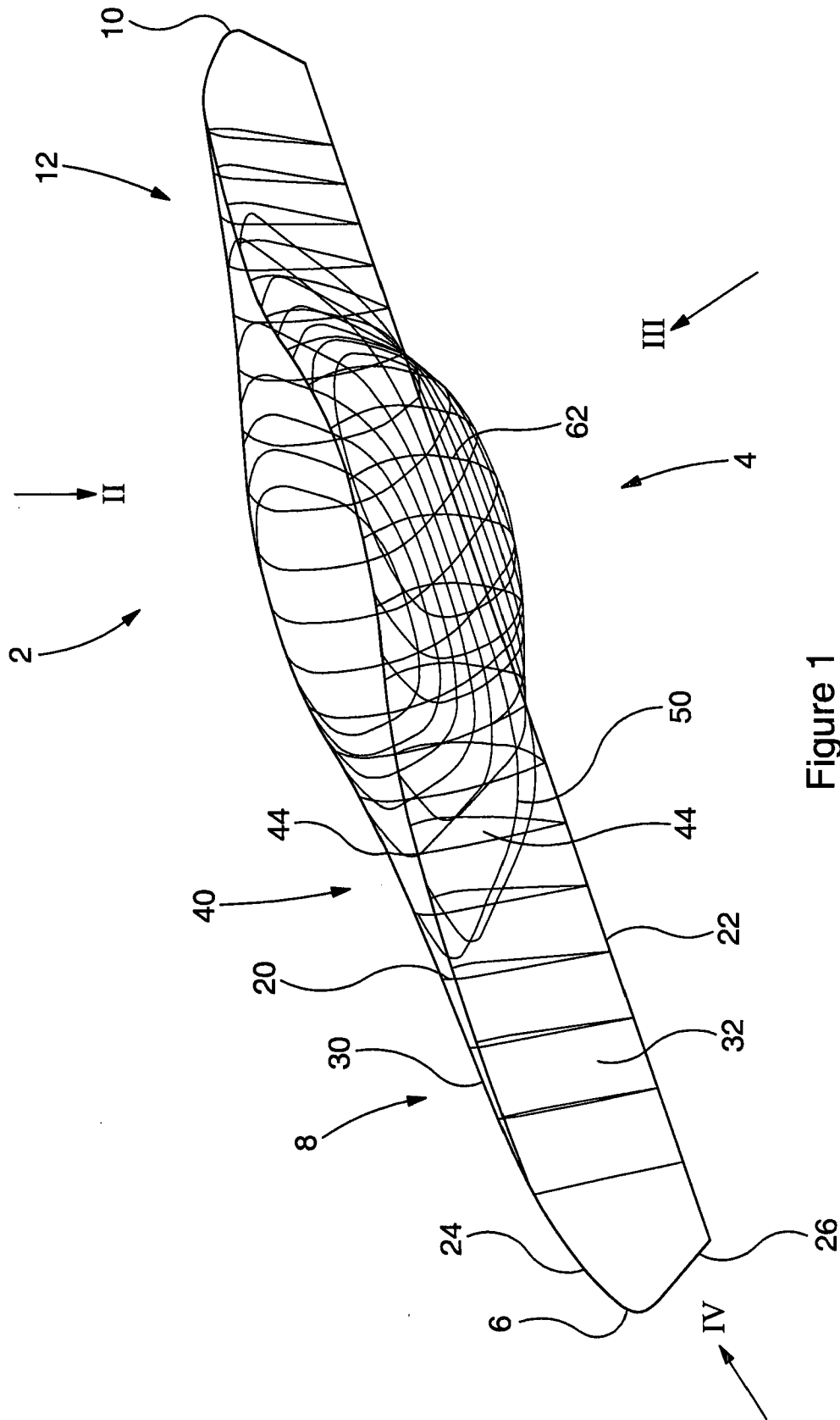

Figure 1

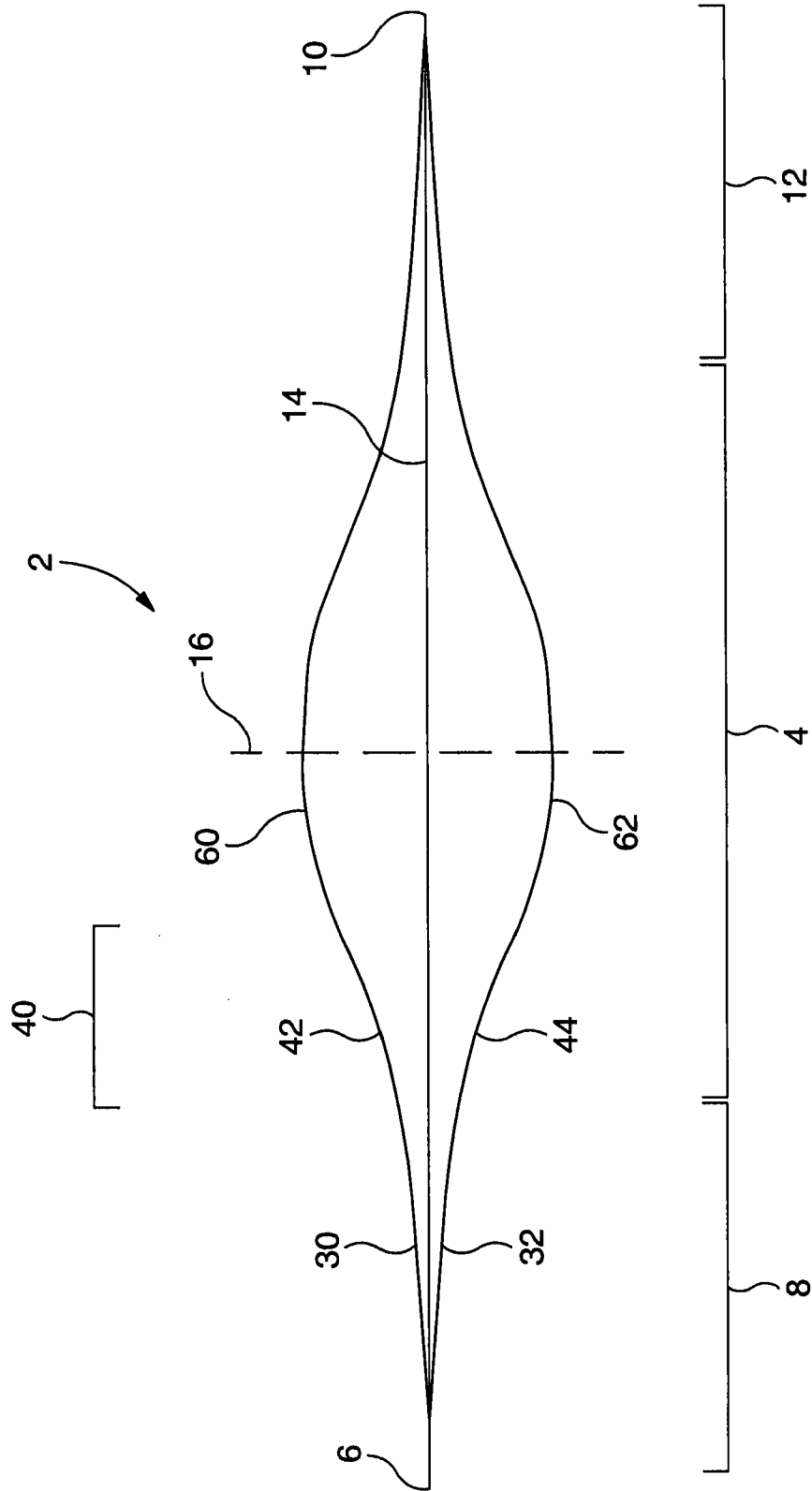

Figure 2

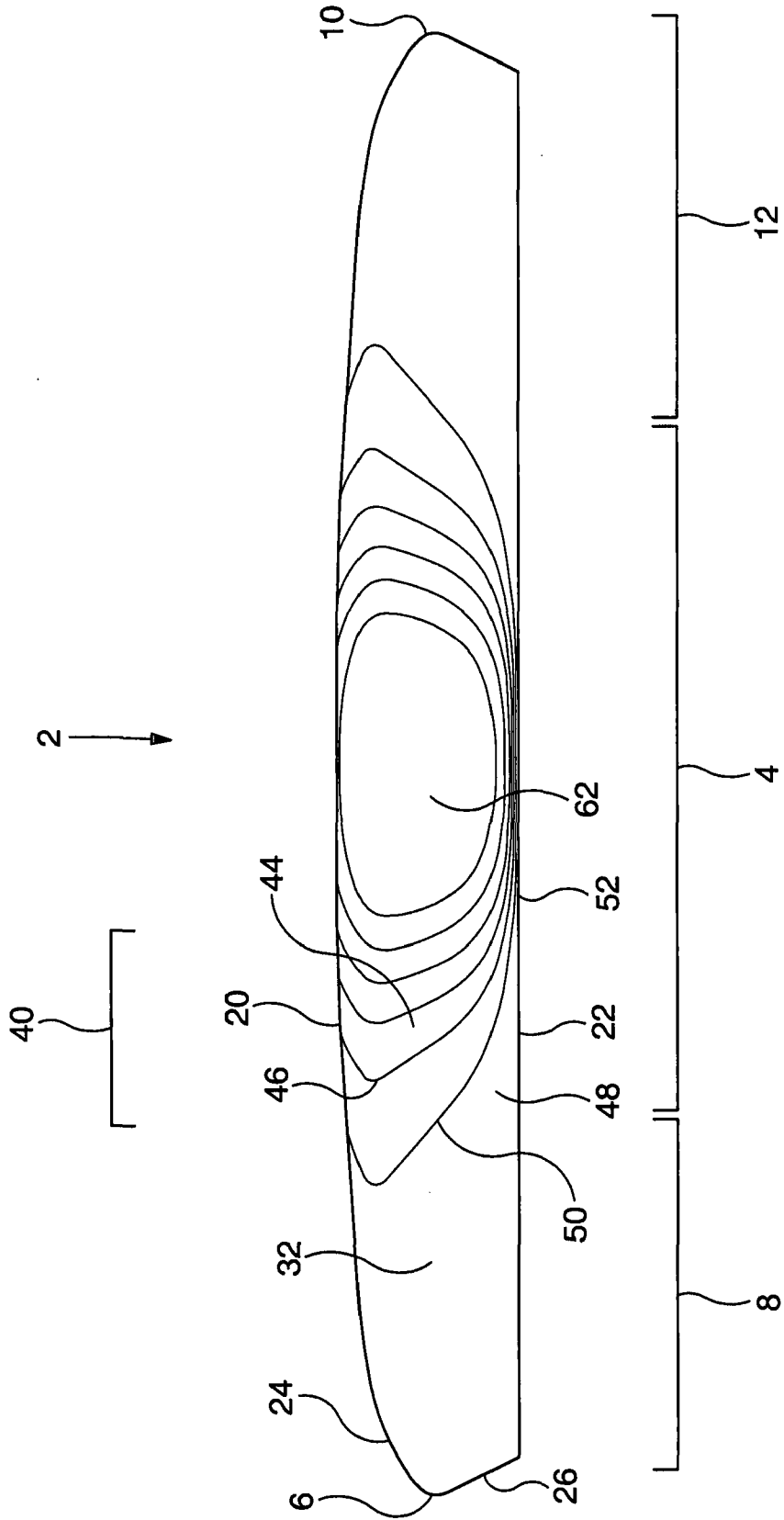

Figure 3

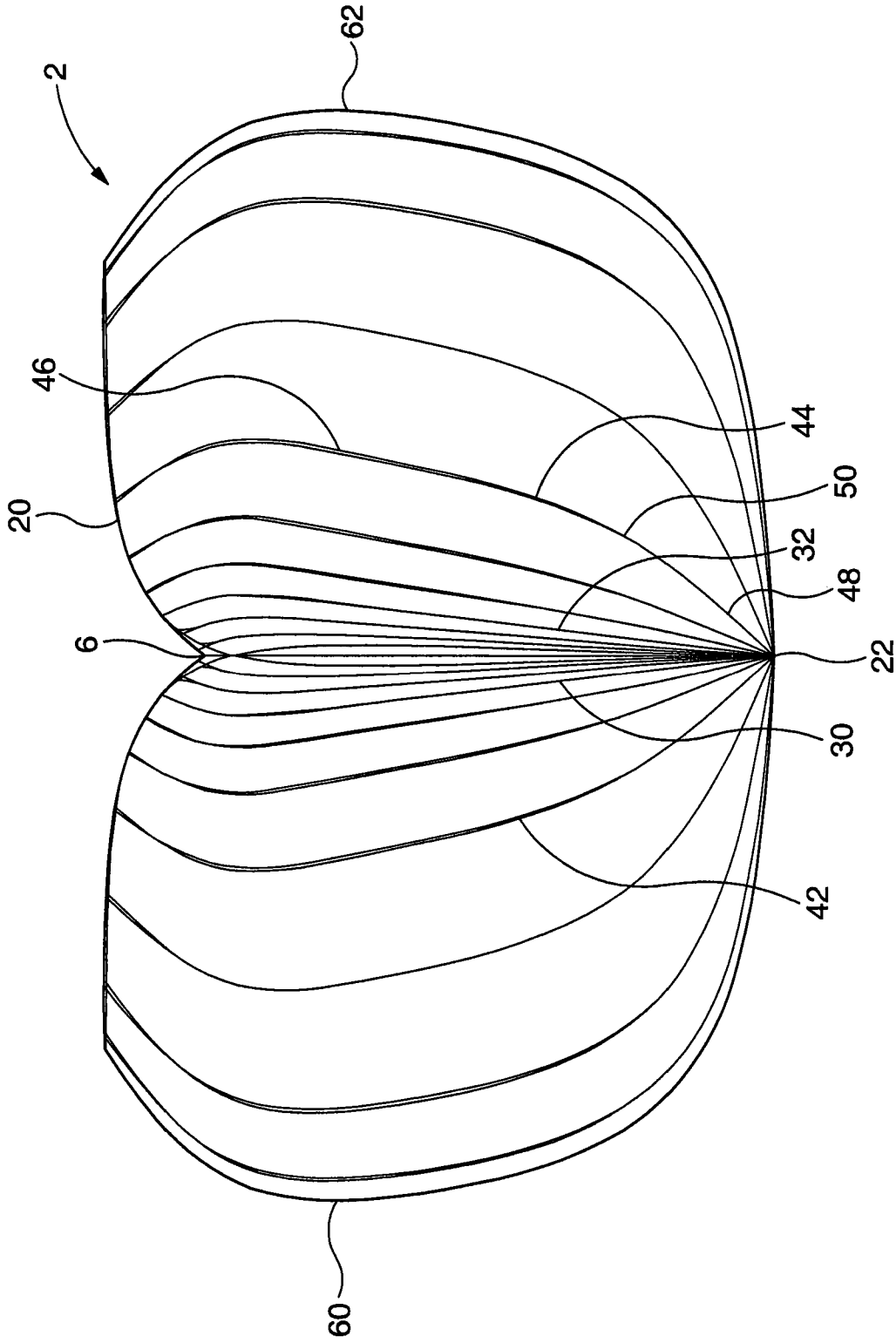

Figure 4

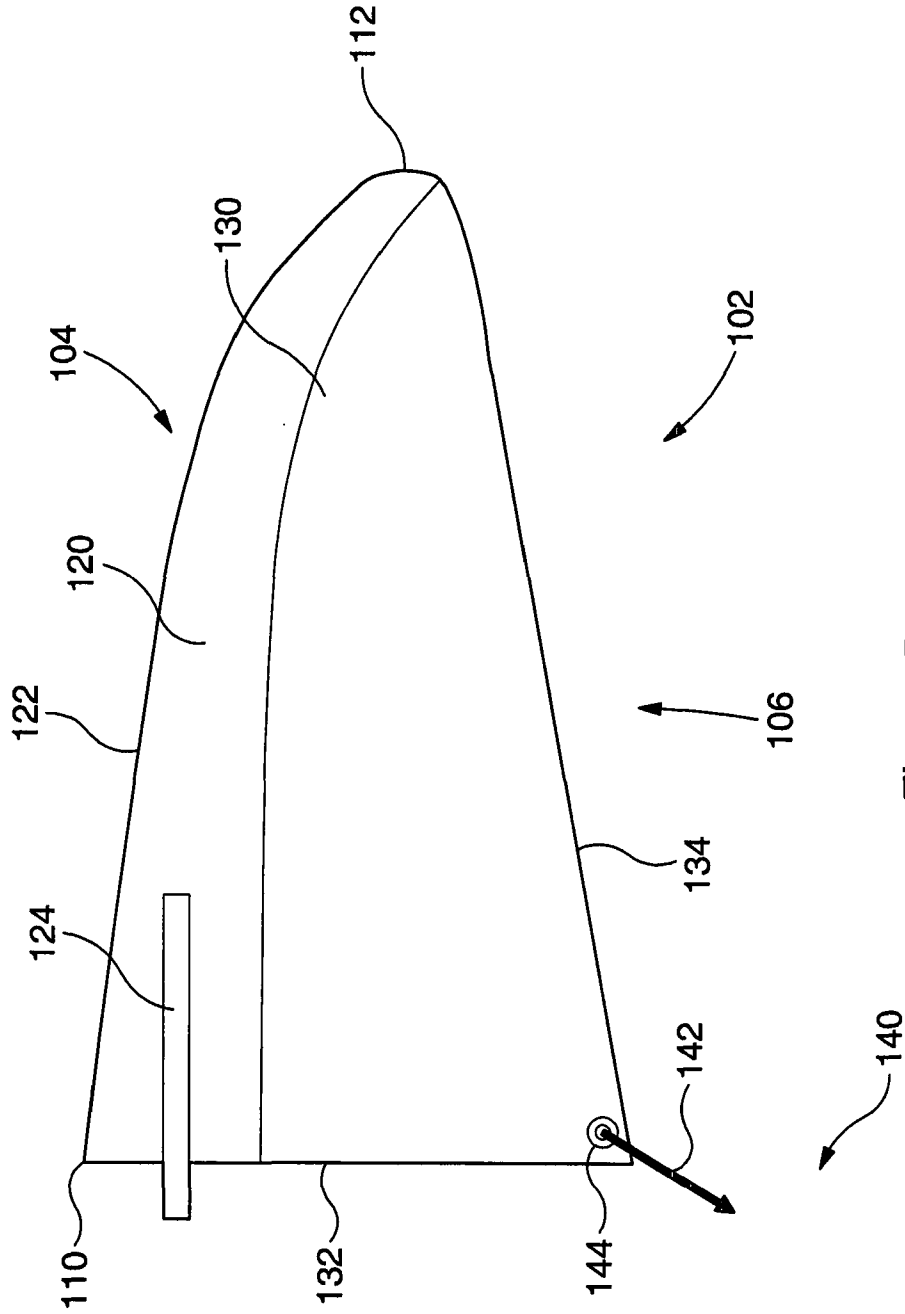

Figure 5a

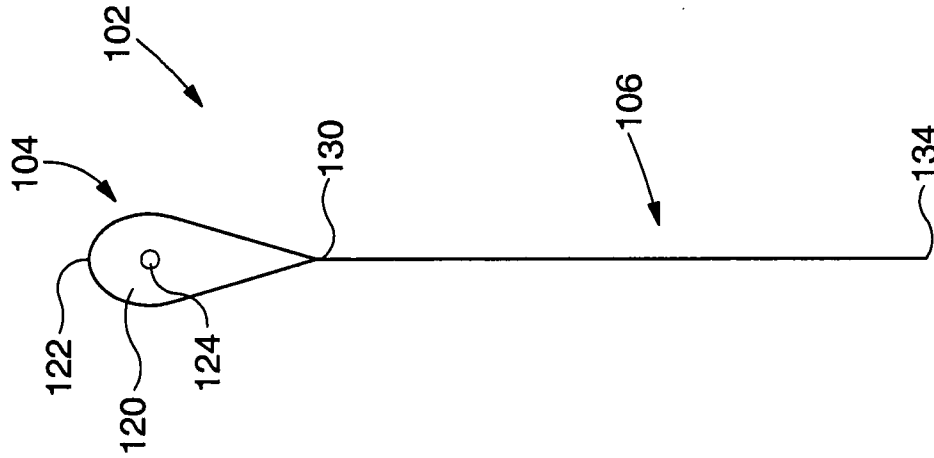

Figure 5b

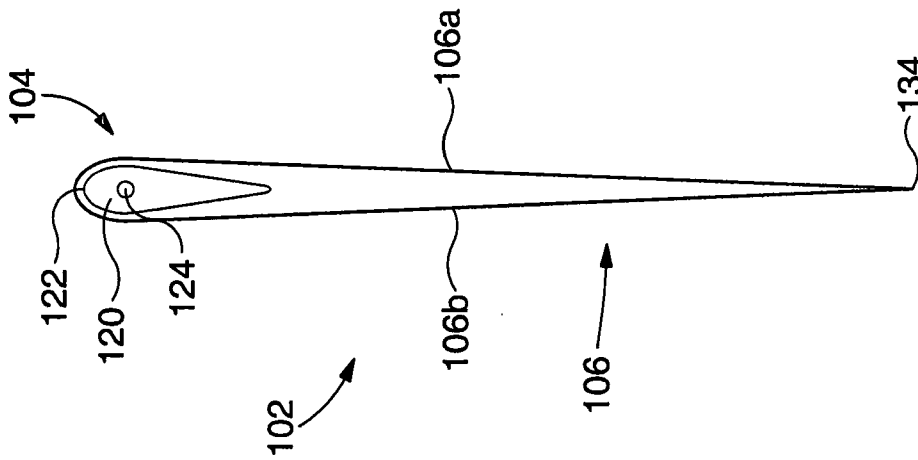

Figure 6

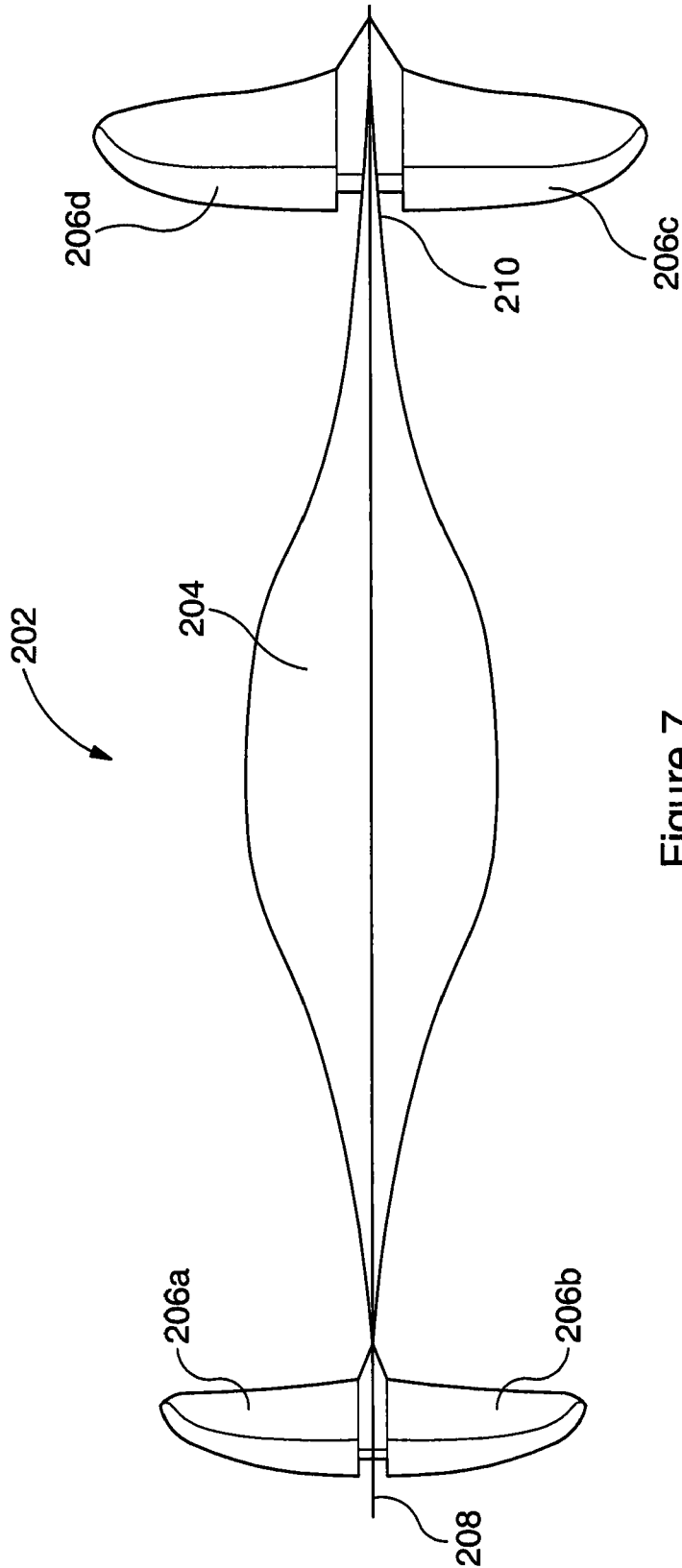

Figure 7