

K. F. KINGWELL.  
 SWITCHING MECHANISM.  
 APPLICATION FILED DEC. 14, 1905.

1,001,650.

Patented Aug. 29, 1911.

2 SHEETS-SHEET 1.

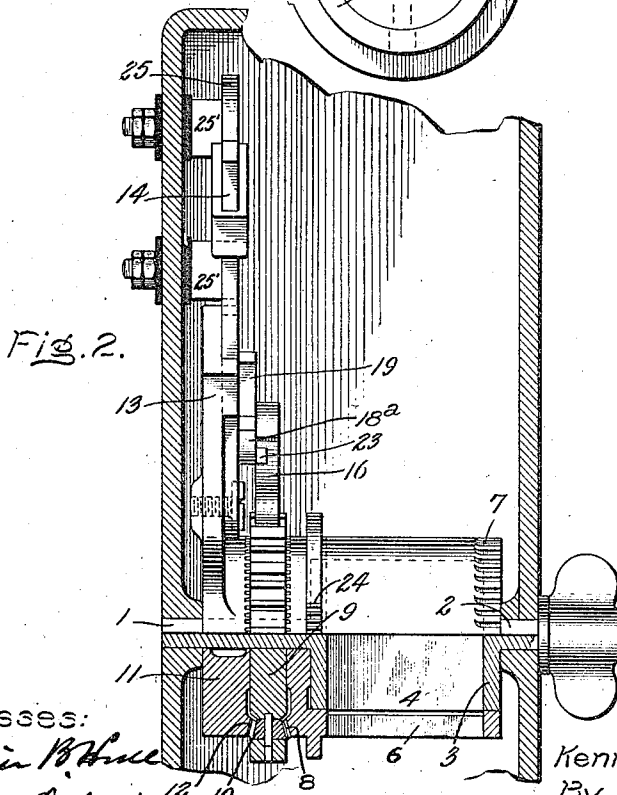
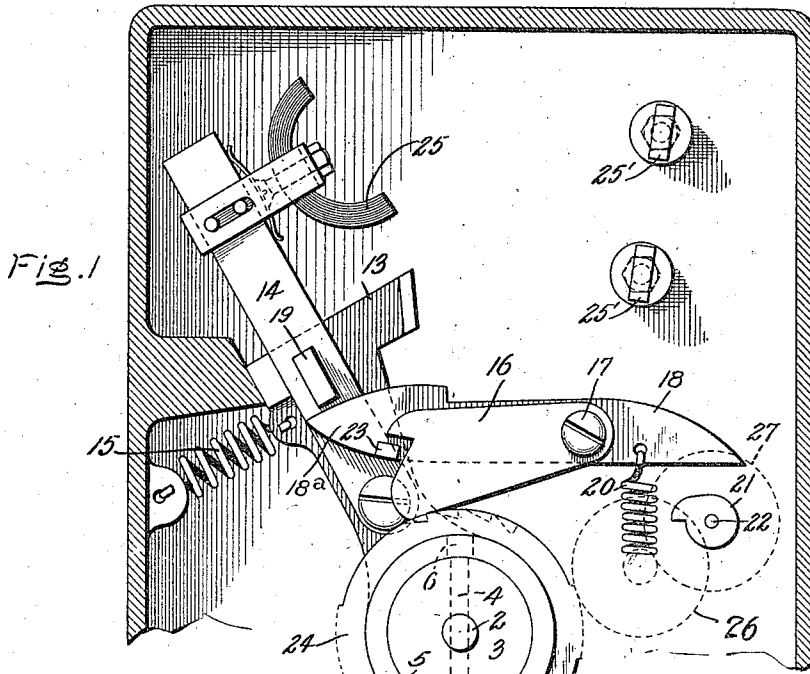

Witnesses:  
*Benjamin B. Hall*  
*Allen Orford*

INVENTOR:  
 Kenneth F. Kingwell,  
 By *Albert H. Davis*  
 Att'y.

Fig. 3.

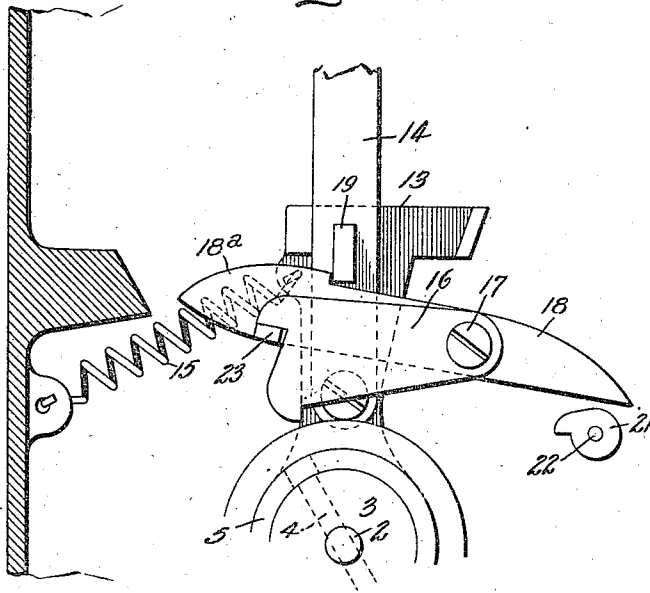
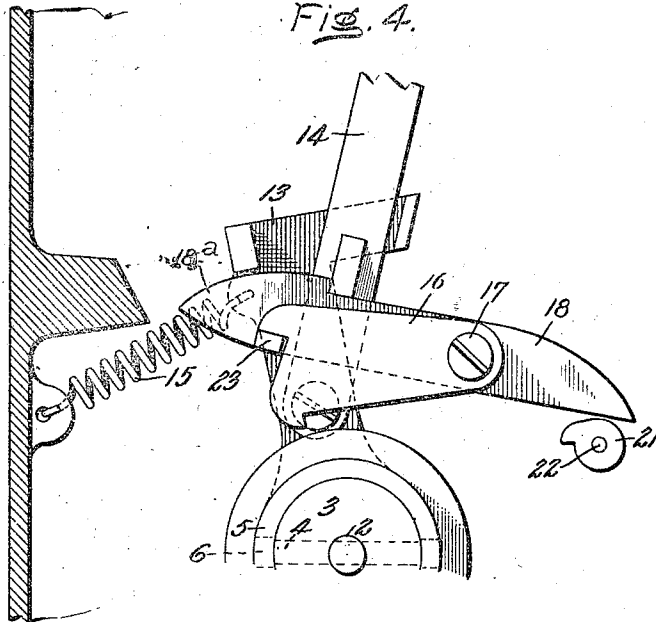

Fig. 4.



WITNESSES:

*Benjamin B. Stone*  
*Alfred Oxford*

INVENTOR:

*Kenneth F. Kingwell,*  
*By Albert H. Davis*  
Att'y.

# UNITED STATES PATENT OFFICE.

KENNETH FRANCIS KINGWELL, OF RUGBY, ENGLAND, ASSIGNOR TO GENERAL ELECTRIC COMPANY, A CORPORATION OF NEW YORK.

## SWITCHING MECHANISM.

1,001,650.

Specification of Letters Patent. Patented Aug. 29, 1911.

Application filed December 14, 1905. Serial No. 291,682.

To all whom it may concern:

Be it known that I, KENNETH FRANCIS KINGWELL, a subject of the King of Great Britain, residing at Rugby, England, have invented certain new and useful Improvements in Switching Mechanisms, of which the following is a specification.

My invention relates to switching mechanism and its object is to provide a mechanism which is simple and inexpensive to manufacture and is not liable to get out of order.

My invention is especially suitable for application to meters of the prepayment type.

I have herein shown my invention embodied in a mechanism comprising a spring controlled lever system adapted to operate the switch or valve mechanism of a meter or other apparatus said lever system being connected to the operating handle through differential gearing, one of the members of which remains locked during part of the movement of the operating handle, the unlocking of said member altering the fulcrum or pivoting point of the main lever of the system and allowing the controlling spring to set the switch or open the valve with a quick movement so that where the invention is used to operate an electric switch injurious sparking at the contacts is prevented.

In the accompanying drawings which illustrate this form of my invention applied to a coin-freed electric meter; Figure 1 is a side elevation of the switch operating mechanism; Fig. 2 is an end elevation of the same; Figs. 3 and 4 are similar views to Fig. 1 showing the positions of the various parts of the mechanism just prior to the closing of the switch and with the switch closed, respectively.

In carrying the invention into effect in the form illustrated in the drawings, I provide a spindle 1 having bearings, one situated within the meter and the other attached to the meter casing. This spindle projects through the casing and is provided at its outer end 2 with an operating handle. Rigidly secured to this spindle is a drum or cylinder 3 provided with a longitudinal slot 4, shown in dotted lines in Fig. 1 adapted to receive a coin. Surrounding this drum is a cylindrical shell or casing 5 also provided with longitudinal slots 6 adapted to

register with the slot in the drum 3. One end of the shell 5 has ratchet teeth 7 formed upon it which are engaged by a spring so as to permit of rotation in one direction only. The other end of the shell has a bevel wheel 8 formed upon it which forms part of a differential gear.

Mounted freely on the same spindle as the drum is a disk 9 provided on its periphery with ratchet teeth and carrying two bevel pinions 10 which gear with the wheel 8 formed on the end of the shell 5. Also mounted loosely on the drum spindle is a hub or boss 11 on which is formed a bevel wheel 12 similar to that on the end of the shell. The disk 9 is mounted between the shell and the hub so that the pinions 10 carried by the disk, gear with the wheels 8 and 12. The hub is provided with an outwardly extending arm or lug 13 to which the switch arm 14 carrying the bridging contact of the meter is pivoted, and which is controlled by a spring 15 secured to the casing or other rigid part. The ratchet teeth on the periphery of the disk 9 are engaged by a pawl 16 which is pivoted on a pin 17 at any convenient point. On the pivot pin 17 is also mounted a spring controlled double ended lever 18 one end 18<sup>a</sup> of which is cam shaped and engages a stop or projection 19 formed on the switch blade 14 the other end being adapted to be raised against the action of the spring 20 by a cam 21 secured to the shaft 22, upon which is also mounted a differential gear such as is described in United States Patent No. 782028, one member of which is shown at 27, thereby permitting of relative movement between the cam and the meter mechanism, so as to lower the cam shaped end 18<sup>a</sup> of the lever out of the path of the projection 19 on the switch blade. The double ended lever 18 is also provided with a small projection 23 adapted when the cam shaped end of the lever is raised, to lift the pawl 16 out of engagement with the ratchet teeth on the disk 9. The measuring out mechanism of the meter is operated by a mutilated gear or worm wheel 24 secured to or formed integral with the shell 5 surrounding the drum.

The operation of the mechanism above described is as follows: When the slots 4 and 6 in the drum and its surrounding shell are in register and a coin of the size for which the meter is designed is inserted in

the slots the edge of the coin projects slightly from the drum slot so that when the spindle is turned by the operating handle the edge of the coin comes into contact with the shell surrounding the drum and locks the drum and shell together. As the ratchet teeth on the periphery of the disk 9 are engaged by the pawl 16 the disk is held against movement, consequently the pinions 10 carried by said disk cause the hub 11 carrying the switch arm to rotate against the action of its retaining spring 15 in the opposite direction from the drum. This causes the projection 19 on the switch arm to ride over the cam surface on the end 18<sup>a</sup> of the double-ended lever until it passes beyond said cam when the spring 20 controlling the lever asserts itself and raises the cam so as to prevent the projection on the switch arm from returning until the opposite end of the lever is raised and the cam depressed by the cam 21 on the meter driven shaft. When the cam-shaped end of the double-ended lever is raised it raises the pawl 16 with it thus freeing the disk 9. When the disk is freed the retaining spring 15 immediately tends to return the hub to its original position, causing the switch arm to pivot about its projection 19 which is held from returning to its original position by the cam on the double-ended lever 18. This causes the outer end of the switch arm to swing quickly over until the bridging member 25 carried by it makes contact with the fixed terminals 25' of the meter with a snap action.

While the operating handle is being turned after the insertion of a coin the mutilated gear or worm 24 carried by or with the shell comes into engagement with the wheel 26 of the measuring out mechanism so as to move the cam 21 on the meter driven shaft through a certain predetermined distance out of engagement with the end of the double-ended lever 18. After the switch is set the current passing through the meter gradually returns the cam 21 until it again comes into contact with the double-ended lever 18, which it lifts until the other end is depressed sufficiently to allow the projection 19 on the switch arm to clear the end of the cam on the lever when the retaining spring 15 returns the hub and switch arm quickly to their initial or "off" position, so that sparking between the contacts and bridging member or breaking the circuit is prevented.

It will be seen from the above description that the movement of the switch blade is only controlled by the operator during a portion of its travel. This is of great advantage as when it is controlled during the whole of its movement, there is a great liability to injurious sparking occurring between the meter contacts and the bridging member owing to the comparative slowness

with which the switch contacts would be closed. With the arrangement described above however, no matter how slowly the switch has been moved through the first portion of its travel, directly it has been turned through a certain angle it will close with a snap.

It will be obvious that although I have particularly described one embodiment of my invention various alterations might be made in the construction of the details of the mechanism without departing from the spirit of my invention. It will also be obvious that the invention will be equally applicable to other coin freed devices besides electric meters.

What I claim as new and desire to secure by Letters Patent of the United States, is,—

1. In combination with a device to be operated, an operating lever therefor, a handle, differential gearing between said lever and said handle, means for locking said gearing to the handle through a portion of the range of movement of said handle, a spring, and means controlled by said spring operative upon the release of said gearing from said handle for completing the movement of said lever.

2. In combination with a device to be operated, an operating lever therefor, a handle, means for locking said lever rigidly to said handle through a portion of the range of movement of said handle, whereby the movement of the handle rotates the lever on its axis, a spring, and means controlled by said spring operative upon the release of said lever from said handle for producing a rotation of said lever on a second axis to complete its movement.

3. The combination of a switch, a lever for closing said switch, an operating handle, means for locking said lever to said handle through a portion of the range of movement of said handle, a spring, and means controlled by said spring for completing the movement of said lever when released from the handle.

4. In combination, a switch mechanism, an operating handle, a rotatable member, means for locking the handle to said member, a differential gear one member of which is secured to one end of said rotatable member, a spring controlled lever system operating said switch mechanism secured to another member of said differential gear the members being normally locked so as to rotate together in opposite directions, and means for releasing said members so that they may rotate independently, substantially as and for the purpose described.

5. The combination of a mechanism pivoted to turn about a center, a member having one end pivoted to said mechanism at some distance from said center, circuit controlling means operated by the opposite

end of said member, means for causing said mechanism and member to turn together about said center through a limited distance, means for thereafter returning said mechanism to its original position, and means engaging said member between its two ends whereby said member is moved pivotally about the point of engagement during the backward movement of said mechanism.

6. The combination of a switch, an operating mechanism therefor comprising a pair of members pivoted together, a handle, means for locking said handle to said members through a portion of its range of movement, and means operative upon the release of said members from said handle for producing a movement of said members relative to each other.

7. The combination of a switch mechanism comprising a pair of members pivoted together, a handle and connections between said handle and said members comprising a differential gearing, means for locking one member of said gearing stationary during a portion of the movement of the device and for thereafter causing said gearing member

to be released, and means controlled by the release of said member for causing one of said pivoted members to move with respect to the other to operate the switch.

8. The combination of a pivoted mechanism, a spring opposing its movement, a member pivoted to said mechanism, a manually controlled device, means connecting said mechanism and member to said device so that an initial movement of the device causes a corresponding movement of the mechanism and member, means set in operation by a further movement of said device for disconnecting said mechanism and device, whereupon the mechanism is returned to its original position by the spring, and means engaging said member between its two ends whereby a backward movement of the mechanism causes said member to turn pivotally about the point of engagement.

In witness whereof, I have hereunto set my hand this 28th day of Nov., 1905.

KENNETH FRANCIS KINGWELL.

Witnesses:

F. M. BURTON,  
H. W. CLARK.