

(19) World Intellectual Property Organization
International Bureau



(10) International Publication Number
WO 2012/003494 A2

(43) International Publication Date
5 January 2012 (05.01.2012)

(51) International Patent Classification:
G01R 22/06 (2006.01)

(21) International Application Number:
PCT/US201 1/042877

(22) International Filing Date:
1 July 2011 (01.07.2011)

(25) Filing Language: English

(26) Publication Language: English

(30) Priority Data:
61/361,296 2 July 2010 (02.07.2010) US
61/380,174 3 September 2010 (03.09.2010) US

(71) Applicant (for all designated States except US):
BELKIN INTERNATIONAL, INC. [US/US]; 12045
East Waterfront Drive, Playa Vista, CA 90094 (US).

(72) Inventors; and

(75) Inventors/Applicants (for US only): **YOGEESWARAN, Karthik** [US/US]; 1450 Fifth Street, Apt. 206, Santa Monica, CA 90401 (US). **KELLY, Frank** [US/US]; 991 Valley High Avenue, Thousand Oaks, CA 91362 (US). **PATEL, Shwetak, N.** [US/US]; 3239 NE 94th Street, Seattle, WA 98115 (US). **GUPTA, Sidhant** [IN/US]; 6900 East Green Lake Way N, #323, Seattle, WA 98115 (US). **REYNOLDS, Matthew, S.** [US/US]; 2322 Englewood Avenue, Durham, NC 27705 (US).

(74) Agent: **OPASKA, Walter P.**; Bryan Cave LLP, Two North Central Avenue, Suite 2200, Phoenix, AZ 85004-4406 (US).

(81) Designated States (unless otherwise indicated, for every kind of national protection available): AE, AG, AL, AM, AO, AT, AU, AZ, BA, BB, BG, BH, BR, BW, BY, BZ, CA, CH, CL, CN, CO, CR, CU, CZ, DE, DK, DM, DO, DZ, EC, EE, EG, ES, FI, GB, GD, GE, GH, GM, GT, HN, HR, HU, ID, IL, IN, IS, JP, KE, KG, KM, KN, KP, KR, KZ, LA, LC, LK, LR, LS, LT, LU, LY, MA, MD, ME, MG, MK, MN, MW, MX, MY, MZ, NA, NG, NI, NO, NZ, OM, PE, PG, PH, PL, PT, RO, RS, RU, SC, SD, SE, SG, SK, SL, SM, ST, SV, SY, TH, TJ, TM, TN, TR, TT, TZ, UA, UG, US, UZ, VC, VN, ZA, ZM, ZW.

(84) Designated States (unless otherwise indicated, for every kind of regional protection available): ARIPO (BW, GH, GM, KE, LR, LS, MW, MZ, NA, SD, SL, SZ, TZ, UG, ZM, ZW), Eurasian (AM, AZ, BY, KG, KZ, MD, RU, TJ, TM), European (AL, AT, BE, BG, CH, CY, CZ, DE, DK, EE, ES, FI, FR, GB, GR, HR, HU, IE, IS, IT, LT, LU, LV, MC, MK, MT, NL, NO, PL, PT, RO, RS, SE, SI, SK, SM, TR), OAPI (BF, BJ, CF, CG, CI, CM, GA, GN, GQ, GW, ML, MR, NE, SN, TD, TG).

[Continued on next page]

(54) Title: SYSTEM FOR MONITORING ELECTRICAL POWER USAGE OF A STRUCTURE AND METHOD OF SAME

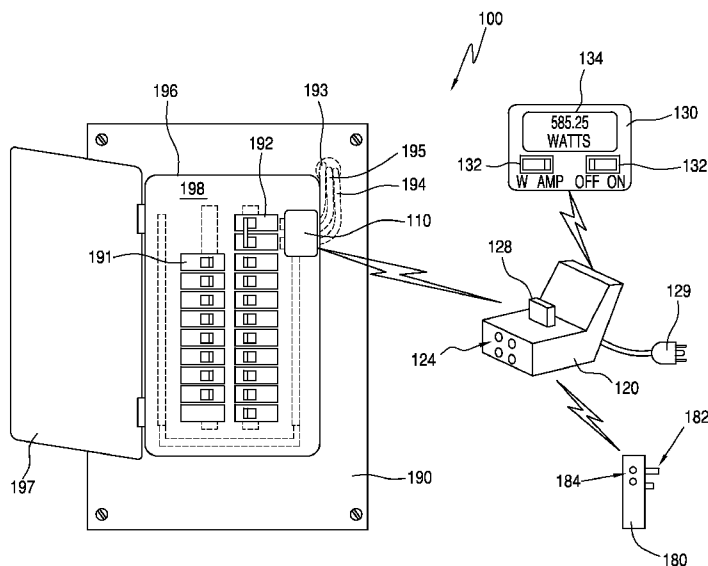

FIG. 1

(57) Abstract: Some embodiments can teach a system for monitoring usage of electrical power by a structure. The structure can have one or more main electrical power lines that supply the electrical power to a first load in the structure. A portion of the one or more main electrical power lines can run substantially parallel to a first axis. The structure can further have a panel that overlies the portion of the one or more main electrical power lines. The system can include: (a) a current sensor unit configured to be coupled to a portion of a surface of the panel, the current sensor unit having: (a) at least one magnetic field sensor having a length substantially parallel to a second axis, wherein the second axis is substantially perpendicular to the first axis, and the at least one magnetic field sensor is configured to detect a magnetic field generated by the one or more main electrical power lines; and (b) a processing unit configured to run on a processor. The current sensor unit can be configured to produce an output signal based on the magnetic field detected by the at least one magnetic field sensor. The processing unit further can be configured to receive the output signal from the current sensor unit and process the output signal to determine one or more parameters related to the usage of the electrical power by the first load in the structure. Other embodiments are disclosed.

figured to receive the output signal from the current sensor unit and process the output signal to determine one or more parameters related to the usage of the electrical power by the first load in the structure. Other embodiments are disclosed.

WO 2012/003494 A2

Published:

— *without international search report and to be republished upon receipt of that report (Rule 48.2(g))*

SYSTEM FOR MONITORING ELECTRICAL POWER USAGE OF A STRUCTURE AND METHOD OF SAME

CROSS-REFERENCE TO RELATED APPLICATIONS

[0001] This application claims the benefit of U.S. Provisional Application No. 61/361,296, filed July 2, 2010 and U.S. Provisional Application No. 61/380,174 filed September 3, 2010. U.S. Provisional Application Nos. 61/361,296 and 61/380,174 are incorporated herein by reference.

FIELD OF THE INVENTION

[0002] This invention relates generally to apparatuses, devices, systems, and methods for monitoring electrical power, and relates more particularly to such apparatuses, devices, systems, and methods that monitor electrical power in one or more main electrical power lines at an electrical circuit breaker panel of a structure.

DESCRIPTION OF THE BACKGROUND

[0003] A structure can have one or more main electrical power lines that supply the electrical power to electrical devices (i.e., the load) in the structure. The main electrical power lines enter the structure through an electrical circuit breaker panel. An electrical circuit breaker panel is the main electrical distribution point for electricity in a structure. Electrical circuit breaker panels also provide protection from over-currents that could cause a fire or damage to electrical devices in the structure. Electrical circuit breaker panels can have three main power lines and use a split-phase electrical power distribution system.

[0004] Different manufacturers of electrical circuit breaker panels, including, for example, Square-D, Eaton, Cutler-Hammer, General Electric, Siemens, and Murray, have chosen different conductor spacing and configurations for their electrical circuit breaker panels. Furthermore, each manufacturer makes many different configurations of electrical circuit breaker panels for indoor installation, outdoor installation, and for different total amperage ratings, of which 100 amperes (A) and 200 A service are the most common in new construction.

[0005] The different conductor layouts in the many different types of electrical circuit breaker panels result in different magnetic field profiles at the metal surfaces of the electrical circuit breaker panels. Moreover, the layout of the internal conductors is not visible without opening the breaker panel and the manner in which the internal conductor layout translates into a magnetic field profile at the surface of the electrical circuit breaker panel requires a detailed knowledge of electromagnetic theory to interpret and model correctly. It is,

therefore, difficult to accurately measure the magnetic field of the one or more main electrical power lines at a surface of the electrical circuit breaker panel.

[0006] Accordingly, a need or potential for benefit exists for an apparatus, system, and/or method that allows a non-electrician to accurately determine the magnetic field of the one or more main electrical power lines at a surface of the electrical circuit breaker panel.

BRIEF DESCRIPTION OF THE DRAWINGS

[0007] To facilitate further description of the embodiments, the following drawings are provided in which:

[0008] FIG. 1 illustrates a view of an exemplary electrical power monitoring system coupled to an electrical circuit breaker panel, according to a first embodiment;

[0009] FIG. 2 illustrates a block diagram of the electrical power monitoring system of FIG. 1, according to the first embodiment;

[0010] FIG. 3 is a graph illustrating the induced voltage versus conductor current for an exemplary electrical circuit breaker panel with a metal panel overlying the main electrical power lines, according to an embodiment;

[0011] FIG. 4 is a graph illustrating the induced voltage versus conductor current for an exemplary electrical circuit breaker panel with a cardboard panel overlying the main electrical power lines, according to an embodiment;

[0012] FIG. 5 is a three-dimensional graph illustrating the measured voltage when a magnetic field sensor is moved horizontally over an electrical conductor and at different heights above the electrical conductor when a steel plate is placed between the electrical conductor and the magnetic field sensor, according to an embodiment;

[0013] FIG. 6 is a three-dimensional graph illustrating the measured voltage when a magnetic field sensor is moved horizontally over an electrical conductor and at different heights above the electrical conductor, according to an embodiment;

[0014] FIG. 7 illustrates exemplary magnetic field sensors located over a surface of the electrical circuit breaker panel of FIG. 1, according to the first embodiment;

[0015] FIG. 8 is a graph illustrating a phase angle of a received sign relative to the voltage versus a position measured using the magnetic fields sensors of FIG. 7, according an embodiment;

[0016] FIG. 9 illustrates exemplary magnetic field sensors of electrical power monitoring system located over a surface of the electrical circuit breaker panel of FIG. 1, according to an embodiment different from FIG. 7;

[0017] FIG. 10 illustrates exemplary magnetic field sensors of an electrical power monitoring system located on a surface of the electrical circuit breaker panel of FIG. 1, according to an embodiment different from FIGs. 7 and 9;

[0018] FIG. 11 illustrates exemplary magnetic field sensors of an electrical power monitoring system located on a surface of the electrical circuit breaker panel of FIG. 1, according to an embodiment different from FIGs. 7, 9, and 10;

[0019] FIG. 12 illustrates an exemplary magnetic field sensors of an electrical power monitoring system located on a surface of the electrical circuit breaker panel of FIG. 1, according to an embodiment different from FIGs. 7 and 9-11;

[0020] FIG. 13 is a graph illustrating the induced voltage versus conductor current for an exemplary electrical circuit breaker panel with a metal panel overlying the main electrical power lines, according to an embodiment;

[0021] FIG. 14 is a graph illustrating a phase angle of a received sign relative to the voltage versus a position measured using the electrical power monitoring system of FIG. 12, according an embodiment;

[0022] FIG. 15 illustrates a graph showing the actual and predicted current measurements of an electrical power monitoring system with a vertically mounted coiled conductor but without a magnet, according to an embodiment;

[0023] FIG. 16 illustrates a graph showing the actual and predicted current measurements of the electrical power monitoring system of FIG. 12, according to an embodiment;

[0024] FIG. 17 illustrates an exemplary coiled conductor of an electrical power monitoring system located on a surface of the electrical circuit breaker panel of FIG. 1, according to an embodiment different from FIGs. 7 and 9-12;

[0025] FIG. 18 illustrates an exemplary magnetic field sensor of an electrical power monitoring system located on a surface of panel of the electrical circuit breaker panel of FIG. 1, according to an embodiment different from FIGs. 7, 9-12, and 17;

[0026] FIG. 19 is a graph illustrating phase angle of a received sign relative to the voltage versus position measured using the electrical power monitoring system of FIG. 18, according an embodiment;

[0027] FIG. 20 illustrates a flow chart for an embodiment of a method of providing a system for monitoring electrical power usage of a structure, according to an embodiment;

[0028] FIG. 21 illustrates a flow chart for an embodiment of an activity of providing a sensing device, according to the embodiment of FIG. 20; and

[0029] FIG. 22 illustrates a flow chart for an embodiment of a method of using a system for monitoring electrical power usage of a structure, according to an embodiment.

[0030] For simplicity and clarity of illustration, the drawing figures illustrate the general manner of construction, and descriptions and details of well-known features and techniques may be omitted to avoid unnecessarily obscuring the invention. Additionally, elements in the drawing figures are not necessarily drawn to scale. For example, the dimensions of some of the elements in the figures may be exaggerated relative to other elements to help improve understanding of embodiments of the present invention. The same reference numerals in different figures denote the same elements.

[0031] The terms "first," "second," "third," "fourth," and the like in the description and in the claims, if any, are used for distinguishing between similar elements and not necessarily for describing a particular sequential or chronological order. It is to be understood that the terms so used are interchangeable under appropriate circumstances such that the embodiments described herein are, for example, capable of operation in sequences other than those illustrated or otherwise described herein. Furthermore, the terms "include," and "have," and any variations thereof, are intended to cover a non-exclusive inclusion, such that a process, method, system, article, device, or apparatus that comprises a list of elements is not necessarily limited to those elements, but may include other elements not expressly listed or inherent to such process, method, system, article, device, or apparatus.

[0032] The terms "left," "right," "front," "back," "top," "bottom," "over," "under," and the like in the description and in the claims, if any, are used for descriptive purposes and not necessarily for describing permanent relative positions. It is to be understood that the terms so used are interchangeable under appropriate circumstances such that the embodiments of the invention described herein are, for example, capable of operation in other orientations than those illustrated or otherwise described herein.

[0033] The terms "couple," "coupled," "couples," "coupling," and the like should be broadly understood and refer to connecting two or more elements or signals, electrically, mechanically and/or otherwise. Two or more electrical elements may be electrically coupled but not be mechanically or otherwise coupled; two or more mechanical elements may be mechanically coupled, but not be electrically or otherwise coupled; two or more electrical elements may be mechanically coupled, but not be electrically or otherwise coupled. Coupling may be for any length of time, e.g., permanent or semi-permanent or only for an instant.

[0034] "Electrical coupling" and the like should be broadly understood and include coupling involving any electrical signal, whether a power signal, a data signal, and/or other types or combinations of electrical signals. "Mechanical coupling" and the like should be broadly understood and include mechanical coupling of all types.

[0035] The absence of the word "removably," "removable," and the like near the word "coupled," and the like does not mean that the coupling, etc. in question is or is not removable.

DETAILED DESCRIPTION OF EXAMPLES OF EMBODIMENTS

[0036] Some embodiments can teach a system for monitoring usage of electrical power by a structure. The structure can have one or more main electrical power lines that supply the electrical power to a first load in the structure. A portion of the one or more main electrical power lines can run substantially parallel to a first axis. The structure can further have a panel that overlies the portion of the one or more main electrical power lines. The system can include: (a) a current sensor unit configured to be coupled to a portion of a surface of the panel, the current sensor unit having: (a) at least one magnetic field sensor having a length substantially parallel to a second axis, wherein the second axis is substantially perpendicular to the first axis, and the at least one magnetic field sensor is configured to detect a magnetic field generated by the one or more main electrical power lines; and (b) a processing unit configured to run on a processor. The current sensor unit can be configured to produce an output signal based on the magnetic field detected by the at least one magnetic field sensor. The processing unit further can be configured to receive the output signal from the current sensor unit and process the output signal to determine one or more parameters related to the usage of the electrical power by the first load in the structure.

[0037] Other embodiments can teach an apparatus for measuring electrical current in one or more main electrical power lines of a structure. The structure can have a breaker box. The breaker box can include at least a first part of the one or more main electrical power lines and a metal panel over the first part of the one or more main electrical power lines. The apparatus can include: (a) a sensing device having: (1) one or more electrical current sensors configured to provide two or more current measurements; and (2) one or more magnets coupled to the one or more electrical current sensors; and (b) a processing module configured to run on a computational unit and configured to use the two or more current measurements to determine the electrical current in the one or more main electrical power lines.

[0038] Yet other embodiments can disclose a method for providing a system for monitoring usage of electrical power of a structure. The structure can have one or more main electrical power lines that supply the electrical power to a first load in the structure. The one or more main electrical power lines at least partially can run substantially parallel to a first axis. The structure can further having a panel that overlies at least part of the one or more main electrical power lines. The method can include: providing a current sensor unit configured to be coupled to a surface of the panel, the current sensor unit configured to produce an output signal based on a magnetic field generated by the one or more main electrical power lines; and providing a processing unit configured to receive the output signal from the current sensor unit and further configured to process the output signal to determine one or more parameters related to the usage of the electrical power of the structure. Providing the current sensor unit can include: providing at least one magnetic field sensor with a length along a second axis, wherein the at least one magnetic field sensor is configured to detect the magnetic field generated by the one or more main electrical power lines; and mounting the at least one magnetic field sensor at the current sensor unit such that the second axis of the at least one magnetic field sensor is substantially perpendicular to the first axis when the current sensor unit is coupled to the surface of the panel.

[0039] Still further embodiments disclose a method for monitoring usage of electrical power of a structure using an electrical power monitoring system. The structure can have one or more main electrical power lines that supply the electrical power to a first load in the structure. The method can include: calibrating the electrical power monitoring system, a first raw current in the one or more main electrical power lines and first calibration data are generated while calibrating the electrical power monitor system; storing the first calibration data and a measurement of the first raw current; measuring a second raw current; performing a first recalibration of the electrical power monitoring system if the second raw current is not within a predetermined amount of the first raw current; if the second raw current is within the predetermined amount of the first raw current, calculating the first measured current using the first calibration data; and displaying the first measured current. Performing the first recalibration of the electrical power monitoring system can include: calibrating the electrical power monitoring system, a third raw current in the one or more main electrical power lines and second calibration data are generated while performing the first recalibration of the electrical power monitor system; storing the second calibration data and a measurement of the third raw current; and calculating a first measured current using the second calibration data.

[0040] FIG. 1 illustrates a view of an exemplary electrical power monitoring system 100 coupled to an electrical breaker panel 190, according to a first embodiment. FIG. 2 illustrates a block diagram of electrical power monitoring system 100, according to the first embodiment. Electrical power monitoring system 100 can also be considered a system for monitoring electrical power usage of a structure. Electrical power monitoring system 100 is merely exemplary and is not limited to the embodiments presented herein. Electrical power monitoring system 100 can be employed in many different embodiments or examples not specifically depicted or described herein. In some examples, electrical power monitoring system 100 can include: (a) a sensing device 110; (b) a computational unit 120; (c) a display device 130; and (d) a calibration device 180.

[0041] Also as shown in FIG. 1, a conventional breaker box or circuit breaker panel 190 can include: (a) two or more individual circuit breakers 191; (b) two or more main circuit breakers 192; (c) main electrical power lines 193, 194, and 195; (d) a panel 196 with an exterior surface 198; and (e) a door 197 that provides access to circuit breakers 191 and 192.

[0042] Main electrical power lines 193, 194, and 195 are electrically coupled to main circuit breakers 192 and supply the electrical power to electrical devices (i.e., the load) in the structure. Panel 196 overlies at least part of main electrical power lines 193, 194, and 195 and associated circuitry to protect people from inadvertently contacting these energized conductors. Usually, panel 196 comprises steel or another metal.

[0043] System 100 can determine the load current in main electrical power lines 193, 194, and 195 by positioning sensing device 110 at surface 198 of panel 196 and measuring the induced voltage in sensing device 110. Electrical power monitoring system 100 can use the measured induced voltage to calculate the electrical current and electrical power in main electrical power lines 193, 194, and 195.

[0044] It is possible to place sensing device 110 anywhere on surface 198 of panel 196 and accurately determine the current in each of the individual branches (including reactive loads). However, to obtain accurate current measurements requires that the magnetic fields from main electrical power lines 193, 194, and 195 to see the same reactance from panel 196 and sensing device 110. If the reactance is not the same, it becomes more difficult to accurately calculate the electrical current and electrical power in main electrical power lines 193, 194, and 195.

[0045] Another potential limitation of measuring the magnetic field created by main electrical power lines 193, 194, and 195 using a sensor unit over panel 196 is that the metal in panel 196 can cause the induced voltage to vary non-linearly with the amount of current

passing through main electrical power lines 193, 194, and 195. Furthermore, the non-linearity of the permeability of the metal of panel 196 can vary from position to position across panel 196. FIG. 3 is a graph 300 illustrating the induced voltage versus conductor current for an exemplary electrical circuit breaker panel with a metal panel overlying the main electrical power lines. FIG. 4 is a graph 400 illustrating the induced voltage versus conductor current for an exemplary electrical circuit breaker panel where the metal panel has replaced with a cardboard panel.

[0046] Similarly, FIG. 5 is a three-dimensional graph 500 illustrating the voltage measured using a magnetic field sensor moved horizontally over an electrical conductor (x-axis) and at different heights above the conductor (y-axis) when a steel plate is placed between the conductor and the magnetic field sensor. FIG. 6 is a three-dimensional graph 600 illustrating the voltage measured using a magnetic field sensor moved horizontally over an electrical conductor (x-axis) and at different heights above the conductor (y-axis) without a steel plate between the conductor and the magnetic field sensor. As illustrated in FIGs. 2-6, the use of a metal panel overlying the main electrical power lines (i.e., panel 196 (FIG. 1)) compared to the use of non-magnetic material (i.e., cardboard) or no material causes a significant non-linearity of the measure voltage on the surface of the panel opposite the main electrical power lines. Furthermore, as shown in FIGs. 5 and 6, this non-linearity is position dependent. That is, the amount of the non-linearity varies based on the position of the sensor on the steel panel. As will be described below, electrical power monitoring system 100 can compensate or eliminate the non-linearity in the induced voltage in sensing device 110 caused by the use of metal in panel 196. Moreover, electrical power monitoring system 100 can ensure that main electrical power lines 193, 194, and 195 see the same reactance from panel 196 and sensing device 110.

[0047] Referring again to FIG. 2, sensing device 110 can include: (a) two or more electrical current sensors or magnetic field sensors 211 and 212; (b) a controller 213; (c) a user communications module 214; (d) a transceiver 215; (e) a power source 216; and (f) a coupling mechanism 219. Controller 213 can be used to control magnetic field sensors 211 and 212, user communications module 214, transceiver 215 and power source 216. In some embodiments, sensing device 110 can include two, four, six, or eight magnetic field sensors. In various examples, magnetic field sensors 211 and 212 can be 2.5 millimeters (mm) to 12.7 mm in diameter.

[0048] In various examples, sensing device 110 can be configured to be coupled to surface 198 (FIG. 1) of panel 196 (FIG. 2) using coupling mechanism 219. In some

examples, coupling mechanism 219 can include an adhesive, a Velcro® material, a magnet, or another attachment mechanism.

[0049] In many embodiments, magnetic field sensors 211 and 212 can include coiled conductors (e.g., coiled wires). FIG. 7 illustrates exemplary magnetic field sensors 211 located over surface 198 of panel 196 with main electrical power lines 193, 194, and 195 under panel 196, according to the first embodiment. In many embodiments, magnetic field sensor 211 can include a coiled conductor 751 with a first end 752 and a second end 753 opposite the first end 752. In some examples, coiled conductor 751 can be coiled in a first direction 743 (e.g., counter-clockwise). Magnetic field sensor 212 can include a coiled conductor 754 with a first end 755 and a second end 756 opposite the first end 755. Coiled conductor 754 can be coiled in a second direction 744 (e.g., clockwise). In many examples, the first direction 743 of the coiling of coiled conductor 751 can be opposite the second direction 744 of the coiling of coiled conductor 754. Coiling the conductor in magnetic field sensors 211 and 212 can help eliminate the non-linearity in the magnetic field.

[0050] In various examples, coiled conductors 751 and 754 can be 2 millimeters (mm) to 12 mm in diameter. Coiled conductor 751 can be spaced apart from coiled conductor 754 by 12 mm to 40 mm. In some examples, the total width of two or more magnetic field sensors can be up to 160 mm. In some examples, coiled conductors can have an air core or a steel core.

[0051] In some examples, at least a portion of surface 198 can be substantially parallel to axes 740 and 742 with at least axis 740 substantially perpendicular to axis 742. In the same or different examples, at least portion of main electrical power lines 193, 194, and 195 can run substantially parallel to axis 740. In the embodiment shown in FIG. 7, axis 741 is substantially perpendicular to axes 740 and 742. Also, axis 741 can run along a length of coiled conductor 751 from first end 752 to second end 753 and along a length of coiled conductor 754 from first end 755 to second end 756. That is, coiled conductors 751 and 754 can be substantially perpendicular to surface 198 and main electrical power lines 193, 194, and 195.

[0052] When magnetic field sensors are placed in the configuration shown in FIG. 7, main electrical power lines 193, 194, and 195 see the substantially the same reactance from panel 196 and sensing device 110. Furthermore, when an electrical power monitoring system has the configuration show in FIG. 7, the steel plate and coiled conductors 751 and 754 have a constant reactance.

[0053] To illustrate that the sensor configuration shown in FIG. 7 has a substantially constant reactance, a fixed current can be placed in main electrical power lines 193, 194, and 195 and coiled conductor 751 can be moved relative to main electrical power lines 193, 194, and 195 while measuring the phase angle of the received signal. If the reactance is constant, the measured phase angle in an ideal coil conductor will exhibit bistable behavior with only two phases that are 180° apart.

[0054] FIG. 8 is a graph 800 illustrating phase angle of a received sign relative to the voltage versus position for electrical power monitoring system 100, according an embodiment. To create graph 800, a fixed current was placed in main electrical power lines 193, 194, and 195 and coiled conductor 751 was moved in approximately 0.6 centimeter (cm) increments relative to main electrical power lines 193, 194, and 195 while measuring the phase angle of the received signal relative to the voltage. As shown in FIG. 8, the phase angle exhibits bistable behavior with has two different phases that are approximately 180° apart. The phase shift occurs when the coil conductor passed over the center of main electrical power line 195. Thus, reactance of coiled conductor 751 and panel 196 as seen by main electrical power lines 193, 194, and 195 is substantially constant.

[0055] Returning to FIG. 2, transceiver 215 can be electrically coupled to magnetic field sensors 211 and 212 and controller 213. In some examples, transceiver 215 communicates the voltages or other parameters measured using magnetic field sensors 211 and 212 to transceiver 221 of computational unit 120. In many examples, transceiver 215 and transceiver 221 can be wireless transceivers. In some examples, electrical signals can be transmitted using WI-FI (wireless fidelity), the IEEE (Institute of Electrical and Electronics Engineers) 802.11 wireless protocol or the Bluetooth 3.0+HS (High Speed) wireless protocol. In further examples, these signals can be transmitted via a Zigbee (802.15.4), Z-Wave, or a proprietary wireless standard. In other examples, transceiver 215 and transceiver 221 can communicate electrical signals using a cellular or wired connection.

[0056] Computational unit 120 can include: (a) transceiver 221; (b) a processing module or unit 222; (c) a power source 223; (d) a user communications device 124; (e) a processor 225; (f) memory 226; (g) calibration module 227; and (h) electrical connector 128. Computational unit 120 can be configured to receive the output signal from sensing device 110 via transceiver 221 and process the output signal to determine one or more parameters related to the electrical power usage of the structure (e.g., the electrical power used by the structure and the electrical current in main electrical power lines 193, 194, and 195).

[0057] In some examples, processing unit 222 can be stored in memory 226 and configured to run on processor 225. Processing unit 222 can be further configured use the current measurements from sensing device 110 to determine one or more parameters related to the electrical power usage of the structure (e.g., the electrical current and electrical power of main electrical power lines 193, 194, and 195). When computational unit 120 is running, program instructions stored in memory 226 are executed by processor 225. A portion of the program instructions, stored in memory 226, can be suitable for carrying out method 2200 (FIG. 22) as described below and/or processing unit 222.

[0058] Calibration module 227 can include one or more calibration loads. In some examples, the one or more calibration loads can be electrically coupling to the first phase branch of the electrical power line infrastructure of structure to help calibrate electrical power monitoring system 100 using electrical connector 128. User communications device 124 can be configured to display information to a user. In one example, user communications device 124 can be a monitor, a touch screen, and/or one or more LEDs (light emitting diodes).

[0059] Power source 223 can provide electrical power to transceiver 221, a user communications device 124, a processor 225, and memory 226. In some examples, power source 223 can include electrical plug 129 that can be coupled to an electrical wall outlet.

[0060] Display device 130 can include (a) a display 134; (b) a control mechanism 132; (c) a transceiver 231 configured to communicate with transceiver 221; (d) power source 233; and/or (e) electrical connector 235. In some embodiments, electrical connector 235 can be configured to couple to electrical connector 128 to couple display device 130 to computational unit 120.

[0061] Calibration device 180 can include: (a) a transceiver 281; (b) an electrical connector 182; (c) a calibration module 283; and (d) a user communication device 184. In some examples, transceiver 281 can be similar or the same as transceivers 215, 221, and/or 231. Electrical connector 182 can be an electrical power plug in some examples. User communication device 184 can be configured to display information to a user. In one example, user communication device 184 can be one or more LEDs.

[0062] Calibration module 283 can include one or more calibration loads. In some examples, the one or more calibration loads can be electrically coupling to the second phase branch of the electrical power line infrastructure of structure to help calibrate electrical power monitoring system 100. That is, in some examples, electrical connector 128 is coupled to an electrical wall outlet coupled to the first phase of the electrical power (e.g. main electrical power line 193 or LI) and electrical connector 182 is coupled to an electrical wall outlet

coupled to the second phase of the electrical power (e.g. main electrical power line 194 or L2). In these examples, main electrical power line 195 is the ground line.

[0063] FIG. 9 illustrates exemplary magnetic field sensors 911 and 912 of electrical power monitoring system 900 located over surface 198 of panel 196 with main electrical power lines 193, 194, and 195 under panel 196, according to an embodiment. Electrical power monitoring system 900 can also be considered a system for monitoring electrical power usage of a structure. Electrical power monitoring system 900 is merely exemplary and is not limited to the embodiments presented herein. Electrical power monitoring system 900 can be employed in many different embodiments or examples not specifically depicted or described herein.

[0064] Referring to FIG. 9, in some examples, electrical power monitoring system 900 can include: (a) a sensing device 910; (b) a computational unit 120 (FIGs. 1 and 2); (c) a display device 130 (FIGs. 1 and 2); and (d) a calibration device 180 (FIGs. 1 and 2). Sensing device 910 can include: (a) two or more electrical current sensors or magnetic field sensors 911 and 912; (b) magnet or magnetic cores 961 and 964; (c) a controller 213 (FIG. 2); (d) a user communications module 214 (FIG. 2); (e) a transceiver 215 (FIG. 2); (f) a power source 216 (FIG. 2); and (g) a coupling mechanism 219 (FIG. 2). Magnetic cores 961 and 964 can be considered part of or coupled to magnetic field sensors 911 and 912. In some examples, magnetic cores 961 and 964 can include an electromagnet or a permanent magnet. Magnetic cores 961 and 964 can be configured to help coupled sensing device 910 to surface 198. In some examples, the north and south poles of magnetic cores 961 and 964 can be located at the ends of the each magnetic core.

[0065] In many examples, magnetic field sensors 911 and 912 can include coiled conductors (e.g., coiled wires). In many embodiments, magnetic field sensor 911 can include a coiled conductor 751 with a first end 752 and a second end 753 opposite the first end 752. In some examples, coiled conductor 751 can be coiled around magnetic core 961 in a first direction 743 (e.g., counter-clockwise). Magnetic field sensor 912 can include a coiled conductor 754 with a first end 755 and a second end 756 opposite the first end 755. Coiled conductor 754 can be coiled around magnetic core 964 in a second direction 744 (e.g., clockwise). In many examples, the first direction 743 of the coiling of coiled conductor 751 can be opposite the second direction 744 of the coiling of coiled conductor 754.

[0066] In some examples, at least a portion of surface 198 can be substantially parallel to axes 740 and 742 with at least axis 740 substantially perpendicular to axis 742. In the same or different examples, at least portion of main electrical power lines 193, 194, and 195 can

run substantially parallel to axis 740. In the embodiment shown in FIG. 9, axis 741 is substantially perpendicular to axes 740 and 742. That is, coiled conductors 751 and 754 can be substantially perpendicular to surface 198 and main electrical power lines 193, 194, and 195. Furthermore, one end of magnetic cores 961 and 964 can be configured to couple to surface 198 of panel 196.

[0067] In some examples, magnetic cores 961 and 964 can help equalize the reactance of panel 196 and coiled conductors 951 and 954 by saturating the magnetic field in the region of panel 196 near magnetic cores 961 and 964. Thus, reactance of coiled conductors 951 and 954 and panel 196 as seen by main electrical power lines 193, 194, and 195 is substantially constant and the non-linearity of the magnetic field caused by panel 196 is substantially eliminated.

[0068] FIG. 10 illustrates exemplary magnetic field sensors 1011, 1012, and 1019 of electrical power monitoring system 1000 located on surface 198 of panel 196, according to an embodiment. Electrical power monitoring system 1000 can also be considered a system for monitoring electrical power usage of a structure. Electrical power monitoring system 1000 is merely exemplary and is not limited to the embodiments presented herein. Electrical power monitoring system 1000 can be employed in many different embodiments or examples not specifically depicted or described herein.

[0069] In some examples, electrical power monitoring system 1000 can include: (a) a sensing device 1010; (b) a computational unit 120 (FIGs. 1 and 2); (c) a display device 130 (FIGs. 1 and 2); and (d) a calibration unit 180 (FIGs. 1 and 2). Sensing device 1010 can include: (a) two or more electrical current sensors or magnetic field sensors 1011, 1012, and 1019; (b) one or more magnets or magnetic cores 961, 964, and 1069; (c) a controller 213 (FIG. 2); (d) a user communications module 214 (FIG. 2); (e) a transceiver 215 (FIG. 2); (f) a power source 216 (FIG. 2); (g) a coupling mechanism 219 (FIG. 2); and (h) one or more ferromagnetic cups or domes 1066, 1067, and 1068. In many embodiments, magnetic field sensors 1011, 1012, and 1019 can include coiled conductors 751, 754, and 1059, respectively. In some examples, coiled conductor 1059 can be similar or the same as coiled conductors 751 and/or 754. Coiled conductors 751, 754, and 1059 can be wrapped around magnetic cores 961, 964, and 1069, respectively. In various embodiments, magnetic cores 961, 964, and 1069 can be coupled to ferromagnetic cups or domes 1066, 1067, and 1068. In many embodiments, magnetic cores 961, 964, and 1069 can extend beyond coiled conductors 751, 754, and 1059, respectively, and be coupled to ferromagnetic cups or domes 1066, 1067, and 1068.

[0070] Domes 1066, 1067, and 1068 can be located over coiled conductors 751, 754, and 1059, respectively. That is, coiled conductors 751, 754, and 1059 are inside or enclosed by domes 1066, 1067, and 1068, respectively. In some examples, the north and south poles of magnetic cores 961, 964, and 1069 can be located at the ends of the each magnetic core. Domes 1066, 1067, and 1068 can be made from steel or another ferromagnetic material.

[0071] In some examples, magnetic cores 961, 964, and 1069 can help equalize the reactance of panel 196 and coiled conductors 951, 954, and 1079, respectively, by saturating the magnetic field in the region of panel 196 near coiled conductors 951, 954, and 1079. Domes 1066, 1067, and 1068 can further focus the magnetic flux lines in the region around and/or below of magnetic cores 961, 964, and 1069, respectively. Thus, the reactance of coiled conductors 951, 954, and 1079 and panel 196 as seen by main electrical power lines 193, 194, and 195 is substantially constant and the non-linearity of the magnetic field caused by panel 196 is eliminated.

[0072] Furthermore, the magnetic field focusing effects of domes 1066, 1067, and 1068 can help decrease the cost of electrical power monitoring system 1000. Because the magnetic field is more focused when domes 1066, 1067, and 1068 are used, magnetic cores 961, 964, and 1069 can be weaker magnets. Accordingly, electrical power monitoring systems with ferromagnetic domes can use less magnetic material or less costly (i.e., weaker) magnetic material.

[0073] FIG. 11 illustrates exemplary magnetic field sensors 1111, 1112, and 1119 of electrical power monitoring system 1100 located on surface 198 of panel 196, according to an embodiment. Electrical power monitoring system 1100 can also be considered a system for monitoring electrical power usage of a structure. Electrical power monitoring system 1100 is merely exemplary and is not limited to the embodiments presented herein. Electrical power monitoring system 1100 can be employed in many different embodiments or examples not specifically depicted or described herein.

[0074] Electrical power monitoring system 1100 can be similar or the same as electrical power monitoring system 1000 except that ferromagnetic domes 1066, 1067, and 1068 are replaced by a single ferromagnetic dome 1166 enclosing coiled conductors 751, 754, and 1059. In some examples, using one ferromagnetic dome instead of individual ferromagnetic domes over each of the coiled conductors can decrease the cost of the electrical power monitoring system.

[0075] FIG. 12 illustrates an exemplary magnetic field sensors 1211 of electrical power monitoring system 1200 located on surface 198 of panel 196, according to an embodiment.

Electrical power monitoring system 1200 can also be considered a system for monitoring electrical power usage of a structure. Electrical power monitoring system 1200 is merely exemplary and is not limited to the embodiments presented herein. Electrical power monitoring system 1200 can be employed in many different embodiments or examples not specifically depicted or described herein.

[0076] In some examples, electrical power monitoring system 1200 can include: (a) a sensing device 1210; (b) a computational unit 120 (FIGs. 1 and 2); (c) a display device 130 (FIGs. 1 and 2); and (d) a calibration unit 180 (FIGs. 1 and 2). Sensing device 1210 can include: (a) at least one electrical current sensor or magnetic field sensor 1211; (b) magnet 1261; (c) a controller 213 (FIG. 2); (d) a user communications module 214 (FIG. 2); (e) a transceiver 215 (FIG. 2); (f) a power source 216 (FIG. 2); and (g) a coupling mechanism 219 (FIG. 2). Magnet 1261 can be considered part of or coupled to magnetic field sensors 1211. In some examples, magnet 1261 is configured to magnetically couple sensing device 1210 to panel 196.

[0077] In many examples, magnetic field sensors 1211 can include coiled conductors (e.g., coiled wires). In many embodiments, magnetic field sensor 1211 can include a coiled conductor 751. In some examples, coiled conductor 751 can be coiled in a first direction 743 (e.g., counter-clockwise). In the embodiment shown in FIG. 12, axis 741 is substantially perpendicular to axes 740 and 742. That is, the length of coiled conductor 751 running from first end 752 to second end 753 can be substantially perpendicular to surface 198 and main electrical power lines 193, 194, and 195.

[0078] Magnet 1261 can have a first side 1248 and a second side 1249 opposite the first side 1248. Second side 1249 can be adjacent to surface 198 of panel 196. In some examples, first end 752 of coiled conductor 751 can be coupled to or adjacent to first side 1248 of magnet 1261. Second end 753 can be spaced apart from first side 1248 of magnet 1261.

[0079] In some examples, magnet 1261 can help equalize the reactance of coiled conductor 751 and panel 196 as seen by main electrical power lines 193, 194, and 195 by saturating the magnetic field in the region of panel 196 near coiled conductor 751. Thus, the reactance of coiled conductor 751 and panel 196 as seen by main electrical power lines 193, 194, and 195 is substantially constant and the non-linearity of the magnetic field caused by panel 196 is eliminated.

[0080] FIG. 13 is a graph 1300 illustrating an induced voltage versus a conductor current for an exemplary electrical circuit breaker panel with a metal panel overlying the main electrical power lines, according to an embodiment. That is, graph 1300 illustrates the

induced voltage versus the conductor current for a sensing device substantially similar to sensing device 1210 and a sensing device substantially similar to sensing device 1210 but without magnet 1261. As illustrated in FIG. 13, the use of magnet 1261 in sensing device 1210 greatly increases the linearity of the induced voltage.

[0081] Similarly, FIG. 14 is a graph 1400 illustrating a phase angle of a received signal (relative to the voltage) versus the position, according an embodiment. To create graph 1400, a fixed current was placed in main electrical power lines 193, 194, and 195 and a sensing device was moved in approximately 0.6 centimeter increments relative to main electrical power lines 193, 194, and 195 while the phase angle of the received signal relative to the voltage was measured. Graph 1400 illustrates the induced voltage versus position for sensing device substantially similar to sensing device 1210 and a sensing device substantially similar to sensing device 1210 but without magnet 1261. As shown in FIG. 14, the phase angle exhibits a much sharper phase angle shift when a sensing device 1210 with magnet 1261 is used. In the region where the phase angle is shifting, it is difficult to measure the phase angle and thus current measurements in these areas can have a higher error rate. By increasing the sharpness of the phase angle shift, the area at which sensing device 1210 provides useable results is greatly increased.

[0082] FIGs. 15 and 16 illustrate the results of two additional test scenarios that show the improved accuracy of electrical power monitoring system 1200 compared to an electrical power monitoring system without a magnet. FIG. 15 illustrates a graph 1500 showing the result of using an electrical power monitoring system with a vertically mounted coiled conductor but without a magnet, according to an embodiment. FIG. 16 illustrates a graph 1600 showing the result of using an electrical power monitoring system 1200 (i.e., a vertically mounted coiled conductor with a magnet), according to an embodiment. FIGs. 15 and 16 show the current measured in each of the electrical phase lines (L1 and L2) by the electrical power monitoring system and the actual current in main electrical power lines 193 (i.e., L1) and main electrical power line 195 (i.e., L2). As shown in FIGs. 15 and 16, use of a magnet as part of the electrical power monitoring system can dramatically decrease the error in the measured current rate. Tests of electrical power monitoring systems 100, 900, 1000, 1100, 1700, and 1800 of FIGs. 1, 9, 10, 11, 17, and 18 show similar increases in linearity and decreases in the error in the measured currents.

[0083] FIG. 17 illustrates exemplary coiled conductor 751 of electrical power monitoring system 1700 located on surface 198 of panel 196, according to an embodiment. Electrical power monitoring system 1700 can also be considered a system for monitoring electrical

power usage of a structure. Electrical power monitoring system 1700 is merely exemplary and is not limited to the embodiments presented herein. Electrical power monitoring system 1700 can be employed in many different embodiments or examples not specifically depicted or described herein.

[0084] Electrical power monitoring system 1700 can be similar or the same as electrical power monitoring system 1200 except electrical power monitoring system 1700 include a ferromagnetic dome 1766 over coiled conductor 751. In some examples, the ends of dome 1766 are located at magnet 1261. In other examples, magnet 1261 is also enclosed by dome 1766. In some examples, the use of dome 1766 in electrical power monitoring system 1200 can focus the magnetic flux lines in the region around and/or below coiled conductor 751.

[0085] FIG. 18 illustrates exemplary magnetic field sensor 1811 of electrical power monitoring system 1800 located on surface 198 of panel 196 with main electrical power lines 193, 194, and 195 under panel 196, according to an embodiment. Electrical power monitoring system 1800 can also be considered a system for monitoring electrical power usage of a structure. Electrical power monitoring system 1800 is merely exemplary and is not limited to the embodiments presented herein. Electrical power monitoring system 1800 can be employed in many different embodiments or examples not specifically depicted or described herein.

[0086] In some examples, electrical power monitoring system 1800 can include: (a) a sensing device 1810; (b) a computational unit 120 (FIGs. 1 and 2); (c) a display device 130 (FIGs. 1 and 2); and (d) a calibration unit 180 (FIGs. 1 and 2). Sensing device 1810 can include: (a) at least one electrical current sensor or magnetic field sensor 1811; (b) a controller 213 (FIG. 2); (c) a user communications module 214 (FIG. 2); (d) a transceiver 215 (FIG. 2); (e) a power source 216 (FIG. 2); and (f) a coupling mechanism 219 (FIG. 2).

[0087] In many embodiments, magnetic field sensor 1811 can include a coiled conductor 1851 with a first end 1852 and a second end 1853 opposite the first end 1852. In the embodiment shown in FIG. 18, a length of coiled conductor 1851 from end 1852 to 1853 can be substantially perpendicular to axis 742. That is, coiled conductor 1851 can be substantially perpendicular to main electrical power lines 193, 194, and 195 and substantially parallel to surface 198. When magnetic field sensors are placed in the configuration shown in FIG. 18, main electrical power lines 193, 194, and 195 see a substantially constant reactance from panel 196 and coiled conductor 951.

[0088] FIG. 19 is a graph 1900 illustrating a phase angle of a received sign relative to the voltage versus a position of magnetic field sensor 1811, according an embodiment. To create

graph 1900, a fixed current was placed in main electrical power lines 193, 194, and 195 and coil conductor 1851 was moved in approximately 0.6 centimeter increments relative to main electrical power lines 193, 194, and 195 while the phase angle of the received signal relative to the voltage was measured. As shown in FIG. 19, the phase angle exhibits bistable behavior with has two different phases approximately 180° apart. The 180° phase shift occurs when the coil passes over the center of main electrical power line 195. Thus, reactance of coil conductor 1851 and panel 196 as seen by main electrical power lines 193, 194, and 195 is substantially constant and the non-linearity of the magnetic field caused by panel 196 is eliminated.

[0089] FIG. 20 illustrates a flow chart for an embodiment of a method 2000 of providing a system for monitoring electrical power usage of a structure. Method 2000 is merely exemplary and is not limited to the embodiments presented herein. Method 2000 can be employed in many different embodiments or examples not specifically depicted or described herein. In some embodiments, the activities, the procedures, and/or the processes of method 2000 can be performed in the order presented. In other embodiments, the activities, the procedures, and/or the processes of the method 2000 can be performed in any other suitable order. In still other embodiments, one or more of the activities, the procedures, and/or the processes in method 2000 can be combined or skipped.

[0090] Referring to FIG. 20, method 2000 includes an activity 2061 of providing a sensing device. As an example, the sensing device can be similar or identical sensing devices 110, 910, 1010, 1210, and 1810 of FIGs. 1, 9, 10, 12, and 18, respectively.

[0091] In some examples, the sensing device can be configured to be coupled to a surface of the panel of an electrical breaker box. The sensing device can be configured to produce an output signal based on the magnetic field generated by one or more main electrical power lines in the electrical breaker box. FIG. 21 illustrates a flow chart for an embodiment of activity 2061 of providing a sensing device, according to the first embodiment.

[0092] Referring to FIG. 21, activity 2061 includes a procedure 2171 of providing one or more magnetic field sensors. In some examples, the magnetic field sensors can be similar to magnetic field sensors 211 and 212 of FIG. 2, magnetic field sensors 911 and 912 of FIG. 9, magnetic field sensor 1011, 1012, 1019 of FIG. 10, magnetic field sensor 1211 of FIG. 12, and/or magnetic field sensor 1811 of FIG. 18. In some examples, the one or more magnetic field sensors can include one or more coiled conductors.

[0093] Next, activity 2061 of FIG. 21 includes a procedure 2172 of mounting the one or more magnetic field sensors to the sensing device. In some examples, procedure 2172 can

include mounting the one or more magnetic field sensors at the sensing device such that an axis of the one or more magnetic field sensors are substantially perpendicular to a least a portion of one or more main electrical power lines and substantially parallel to the surface of the panel when the sensing device is coupled to the surface of the panel.

[0094] In other examples, procedure 2172 can include mounting the one or more magnetic field sensors at the sensing device such that an axis of the one or more magnetic field sensors are substantially perpendicular to a least a portion of one or more main electrical power lines and substantially perpendicular the surface of the panel when the sensing device is coupled to the surface of the panel. In various examples, the one or more magnetic field sensors at the sensing device are mounted such that an axis of the one or more magnetic field sensors are substantially perpendicular to a portion of one or more main electrical power lines directly below the magnetic field sensors and substantially perpendicular the surface of the panel when the sensing device is coupled to the surface of the panel

[0095] Activity 2061 in FIG. 21 continues with a procedure 2173 of providing one or more magnets. As an example, the one or more magnets can be similar to magnetic cores 961 and 964 of FIG. 9, magnetic core 1069 of FIG. 10, and/or magnet 1261 of FIG. 12.

[0096] Subsequently, activity 2061 of FIG. 21 includes a procedure 2174 of coupling the one or more magnets to the one or more magnetic sensors. In some examples, coupling one or more magnetic sensors to the one or more magnets can include wrapping the one or more coiled conductors of the magnetic fields sensors around the one or more magnets. For example, the coiled conductors of the magnetic fields sensors can be wrapped around the one or more magnets can be similar to the coiled conductors wrapped around the one or more magnets as shown in FIGs. 9, 10, and/or 11.

[0097] In other embodiments coupling one or more magnetic sensors to the one or more magnets can include coupling one end of the magnetic field sensor to the one or more magnets. For example, coupling one end of the magnetic fields sensors to the one or more magnets can be similar to the coupling one end of the magnetic fields sensors to the one or more magnets as shown in FIGs. 12, and/or 13. In alternative examples, activity 2061 does not include procedures 2173 and 2174.

[0098] Next, activity 2061 of FIG. 21 includes a procedure 2175 of providing one or more ferromagnetic domes. As an example, the one or more ferromagnetic domes can be similar to domes 1066, 1067, and 1068 of FIG. 10, dome 1166 of FIG. 11 and/or dome 1766 of FIG. 16.

[0099] Activity 2061 in FIG. 21 continues with a procedure 2176 of mounting the one or more ferromagnetic domes such that the one or more magnetic field sensors are located within the one or more domes. For example, the one or more magnetic field sensors located within the one or more domes can be similar to the one or more magnetic field sensors located within the one or more domes as shown in FIGs. 10, 11, and/or 16. In alternative examples, activity 2061 does not include procedures 2175 and 2176.

[00100] Subsequently, activity 2061 of FIG. 21 includes a procedure 2177 of providing one or more additional components of the sensing device. In some examples, the one or more additional components can include a controller, a power source, a transceiver, a user communications module, and/or a coupling mechanism. After procedure 2174, activity 2061 is complete.

[00101] Referring again to FIG. 20, method 2000 in FIG. 20 continues with an activity 2062 of providing a computational device. As an example, the computational device can be similar or identical computational unit 120 of FIGs. 1 and 2. In some examples, activity 2062 can, instead, include just providing a processing unit. As an example, the processing unit can be similar or identical processing unit 222 of FIG. 2. In some examples, the processing unit can be configured to receive the output signal from the sensing device and further configured to process the output signal to determine one or more parameters related to the electrical power usage of the structure.

[00102] Subsequently, method 2000 of FIG. 20 includes an activity 2063 of providing a calibration device. As an example, the calibration device can be similar or identical calibration device 180 of FIGs. 1 and 2.

[00103] Subsequently, method 2000 of FIG. 20 includes an activity 2064 of providing a display device. As an example, the calibration device can be similar or identical display device 130 of FIGs. 1 and 2. In some examples, the display device can be part of computational unit 120.

[00104] In addition to mitigating the non-linearity of the magnetic field by changing the configuration of the sensing device, the non-linearity of the magnetic field can be mitigated by modifying the method of calibrating and using the electrical power monitoring system. FIG. 22 illustrates a flow chart for an embodiment of a method 2200 of using a system for monitoring electrical power usage of a first load of a structure. Method 2200 is merely exemplary and is not limited to the embodiments presented herein. Method 2200 can be employed in many different embodiments or examples not specifically depicted or described herein. In some embodiments, the activities, the procedures, and/or the processes of method

2200 can be performed in the order presented. In other embodiments, the activities, the procedures, and/or the processes of the method 2200 can be performed in any other suitable order. In still other embodiments, one or more of the activities, the procedures, and/or the processes in method 2200 can be combined or skipped.

[00105] Referring to FIG. 22, method 2200 includes an activity 2261 of providing an electrical power monitoring system. As an example, the electrical power monitoring system can be similar or identical to electrical power monitoring systems 100, 900, 1000, 1100, 1200, 1700, and 1800 of FIGs. 1, 9, 10, 11, 12, 17, and 18, respectively.

[00106] Method 2200 in FIG. 22 continues with an activity 2262 of calibrating the electrical power monitoring system. In some examples, a first calibration can be performed when the electrical power monitoring system is first installed or powered-up. In some examples, a computational device of the electrical power monitoring system is plugged into a first phase line (e.g., L1) of the electrical power system of the structure and a calibration device of the electrical power monitoring system is plugged into a second phase line (e.g., L2) of the electrical power system of the structure.

[00107] In some examples, calibrating the electrical power monitoring system can first include determining a first amplitude and a first phase of a first current in each of the current sensors of the sensing device. Afterwards, a first load in the computational device is coupled to the first phase branch and a second amplitude and a second phase of a second current in each of the current sensors of the sensing device are determined. Next, a second predetermined load in the calibration device is coupled to the second phase branch and a third amplitude and a third phase of a third current in each of the current sensors are determined. Finally, one or more calibration factors are determined for the sensing device at least in part using the first amplitudes, the first phases, the second amplitudes, the second phases, the third amplitudes, and the third phases.

[00108] Subsequently, method 2200 of FIG. 22 includes an activity 2263 of storing the calibration data. In some examples, the calibration data can include the calibration factors and the first amplitude and the first phase of a first current. The calibration data can be stored in memory in the computational device.

[00109] Next, method 2200 of FIG. 22 includes an activity 2264 of measuring a raw current.

[00110] Method 2200 in FIG. 22 continues with an activity 2265 of determining if the raw current different by a predetermined amount from stored calibration data. If the current is

within a predetermined amount of the current of the stored calibration data, the next activity is activity 2266 of calculating the measure current.

[001 11] If the raw current is not within a predetermined amount (e.g., 1 percent (%), 5%, 10%, or 25%) of the first current, the next activity is activity 2262 of calibrating the electrical power monitoring system. The new calibration parameters and new first current can be stored in memory. Thus, a database of calibration data and raw currents can be created. Thus, in activity 2265, the raw current can be compared to all of the calibration data stored in the memory. If the raw current is not within a predetermined amount of the stored calibration data, the electrical power monitoring system can be recalibrated. That is, a new calibration would occur anytime electrical power monitoring system detects that a large change in the current has occurred from previously measured currents. Thus, the non-linearity in the magnetic field can be mitigated by re-calibrating the electrical power monitoring system anytime a large change in the current of the main electrical power lines occurs.

[001 12] Subsequently, method 2200 of FIG. 22 includes an activity 2266 of calculating the measured current using the stored calibration data.

[001 13] Afterwards, method 2200 continues with an activity 2267 of displaying the measured current. In some examples, the measured current can be displayed using display device 130.

[001 14] Although the invention has been described with reference to specific embodiments, it will be understood by those skilled in the art that various changes may be made without departing from the spirit or scope of the invention. Accordingly, the disclosure of embodiments of the invention is intended to be illustrative of the scope of the invention and is not intended to be limiting. It is intended that the scope of the invention shall be limited only to the extent required by the appended claims. For example, to one of ordinary skill in the art, it will be readily apparent that activities 2061, 2062, 2063, and 2064 of FIG. 20, procedures 2171, 2172, 2173, 2174, 2175, 2176, and 2177 of FIG. 20, and activities 2261, 2262, 2263, 2264, 2265, 2266, 2267 of FIG. 22 may be comprised of many different activities, procedures and be performed by many different modules, in many different orders that any element of FIGs. 1, 2, 7, 9, 10, 11, 12, 17, and 18 may be modified and that the foregoing discussion of certain of these embodiments does not necessarily represent a complete description of all possible embodiments.

[001 15] All elements claimed in any particular claim are essential to the embodiment claimed in that particular claim. Consequently, replacement of one or more claimed elements constitutes reconstruction and not repair. Additionally, benefits, other advantages, and

solutions to problems have been described with regard to specific embodiments. The benefits, advantages, solutions to problems, and any element or elements that may cause any benefit, advantage, or solution to occur or become more pronounced, however, are not to be construed as critical, required, or essential features or elements of any or all of the claims, unless such benefits, advantages, solutions, or elements are stated in such claim.

[001 16] Moreover, embodiments and limitations disclosed herein are not dedicated to the public under the doctrine of dedication if the embodiments and/or limitations: (1) are not expressly claimed in the claims; and (2) are or are potentially equivalents of express elements and/or limitations in the claims under the doctrine of equivalents.

CLAIMS

What is claimed is:

1. A system for monitoring usage of electrical power by a structure, the structure having one or more main electrical power lines that supply the electrical power to a first load in the structure, a portion of the one or more main electrical power lines run substantially parallel to a first axis, the structure further having a panel that overlies the portion of the one or more main electrical power lines, the system comprising:

a current sensor unit configured to be coupled to a portion of a surface of the panel, the current sensor unit comprising:

at least one magnetic field sensor having a length substantially parallel to a second axis, wherein the second axis is substantially perpendicular to the first axis, and the at least one magnetic field sensor is configured to detect a magnetic field generated by the one or more main electrical power lines; and

a processing unit configured to run on a processor,

wherein:

the current sensor unit is configured to produce an output signal based on the magnetic field detected by the at least one magnetic field sensor; and

the processing unit further is configured to receive the output signal from the current sensor unit and process the output signal to determine one or more parameters related to the usage of the electrical power by the first load in the structure.

2. The system of claim 1, wherein:

the second axis is also substantially perpendicular to the portion of the surface of the panel; and

at least part of the portion of the surface of the panel overlies the portion of the one or more main electrical power lines.

3. The system of claim 1, wherein:

the second axis is also substantially parallel to the portion of the surface of the panel; and

at least part of the portion of the surface of the panel overlies the portion of the one or more main electrical power lines.

4. The system of one of claim 1, 2, or 3, wherein:
the at least one magnetic field sensor comprises:
a first magnetic field sensor comprising:
a first core; and
a first conductor wrapped around the first core in a first direction; and
a second magnetic field sensor comprising:
a second core; and
a second conductor wrapped around the second core in a second direction; and
the second direction is opposite the first direction.
5. The system of claim 4, wherein:
the first direction is clockwise; and
the second direction is counter-clockwise.
6. The system of one of claim 1, 2, 3, 4, or 5 wherein:
the current sensor unit further comprises:
at least one magnet.
7. The system of claim 6, wherein:
the at least one magnetic field sensor has a first end and a second end opposite the first end;
the length of the at least one magnetic field sensor extends from the first end to the second end;
the first end is adjacent to the at least one magnet;
the at least one magnet is configured to be adjacent to the panel; and
the second axis is substantially perpendicular to the part of the surface of the panel.
8. The system of claim 7, wherein:
the current sensor unit further comprises:
a ferromagnetic dome over the at least one magnetic field sensor.
9. The system of one of claim 6 or 7, wherein:
the at least one magnetic field sensor comprises:
a first magnetic field sensor comprising:

a first conductor wrapped around the at least one magnet.

10. The system of claim 9, wherein:

the current sensor unit further comprises:

a ferromagnetic dome over the first conductor.

11. The system of one of claim 6, 7, 8, 9, or 10, wherein:

the at least one magnet comprises an electromagnet or a permanent magnet.

12. The system of one of claim 6, 7, 8, or 11, wherein:

the at least one magnetic is configured to magnetically couple the current sensor unit to the panel.

13. The system of one of claim 1, 2, 3, 4, 5, 6, 7, 8, 9, 10, 11, or 12, wherein:

the one or more parameters related to the usage of the electrical power by the structure comprise the electrical power used by the first load in the structure; and

the first load comprises two or more electrical devices coupled to the one or more electrical power lines.

14. An apparatus for measuring electrical current in one or more main electrical power lines of a structure, the structure having a breaker box, the breaker box comprising at least a first part of the one or more main electrical power lines and a metal panel over the first part of the one or more main electrical power lines, the apparatus comprising:
- a sensing device comprising:
 - one or more electrical current sensors configured to provide two or more current measurements; and
 - one or more magnets coupled to the one or more electrical current sensors; and
 - a processing module configured to run on a computational unit and configured to use the two or more current measurements to determine the electrical current in the one or more main electrical power lines.
15. The apparatus of claim 14, wherein:
- each of the one or more electrical current sensors comprise:
 - a first side; and
 - a second side opposite the first side;
 - a first axis extends from the first side to the second side of each of the one or more electrical current sensors; and
 - each of the first axes are perpendicular to a portion of a length of the first part of the one or more main electrical power lines.
16. The apparatus of claim 15, wherein:
- each of the first axes are also perpendicular to at least part of an exterior side of the metal panel.
17. The apparatus of one of claim 15 or 16, wherein:
- the first side of each of the one or more electrical current sensors is coupled to the one or more magnets; and
 - the second side of each of the one or more electrical current sensors is spaced apart from the one or more magnets.
18. The apparatus of one of claim 15, 16, or 17, wherein:
- the first axis is also parallel to at least part of an exterior side of the metal panel.

19. The apparatus of one of claim 14, 15, 16, 17, or 18, wherein:
at least one of the one or more electric current sensors is enclosed by a ferromagnetic cup.

20. The apparatus of one of claim 14, 15, 16, 17, or 18, wherein:
the one or more magnets are configured to couple to an exterior side of the metal panel.

21. The apparatus of one of claim 14, 15, 16, 17, 18, 19 or 20, wherein:
the one or more electrical current sensors comprise:
a first conductor coiled around a first one of the one or more magnets; and
a second conductor coiled around a second one of the one or more magnets.

22. The apparatus of one of claim 14, 15, 16, 17, 18, 20, or 21, further comprising:
at least one ferromagnetic cup,

wherein:

the one or more electric current sensors are enclosed by the at least one ferromagnetic cup.

23. The apparatus of one of claim 14, 15, 16, 17, 18, or 20, further comprising:
a first ferromagnetic cup; and
a second ferromagnetic cup,

wherein:

the one or more electrical current sensors comprise:

a first conductor coiled around a first one of the one or more magnets; and
a second conductor coiled around a second one of the one or more magnets;

the first conductor and the first one of the one or more magnets are inside the first ferromagnetic cup; and

the second conductor and the second one of the one or more magnets are inside the second ferromagnetic cup.

24. A method for providing a system for monitoring usage of electrical power of a structure, the structure having one or more main electrical power lines that supply the electrical power to a first load in the structure, the one or more main electrical power lines at least partially run substantially parallel to a first axis, the structure further having a panel that overlies at least part of the one or more main electrical power lines, the method comprising:

providing a current sensor unit configured to be coupled to a surface of the panel, the current sensor unit configured to produce an output signal based on a magnetic field generated by the one or more main electrical power lines; and

providing a processing unit configured to receive the output signal from the current sensor unit and further configured to process the output signal to determine one or more parameters related to the usage of the electrical power of the structure,

wherein:

providing the current sensor unit comprises:

providing at least one magnetic field sensor with a length along a second axis, wherein the at least one magnetic field sensor is configured to detect the magnetic field generated by the one or more main electrical power lines; and

mounting the at least one magnetic field sensor at the current sensor unit such that the second axis of the at least one magnetic field sensor is substantially perpendicular to the first axis when the current sensor unit is coupled to the surface of the panel.

25. The method of claim 24, wherein:

mounting the at least one magnetic field sensor further comprises:

mounting the at least one magnetic field sensor at the current sensor unit such that the second axis of the at least one magnetic field sensor is substantially perpendicular to the first axis and substantially perpendicular to at least part of the surface of the panel when the current sensor unit is coupled to the surface of the panel.

26. The method of claim 24, wherein:

mounting the at least one magnetic field sensor further comprises:

mounting the at least one magnetic field sensor at the current sensor unit such that the second axis of the at least one magnetic field sensor is substantially perpendicular to the first axis and is substantially parallel to at least part of the surface of the panel when the current sensor unit is coupled to the surface of the panel.

27. The method of one of claim 24, 25 or 26, wherein:

providing the at least one magnetic field sensor further comprises:

providing the at least one magnetic field sensor with a first end and a second end opposite the first end, the second axis extends from the first end to the second end; and providing the current sensor unit comprises:

providing at least one magnet coupled to a first end of the at least one magnetic field sensor.

28. The method of one of claim 24, 25, 26, or 27, further comprising:

providing one or more ferromagnetic cups; and

mounting the one or more ferromagnetic cups such that the at least one magnetic field sensor is located within the one or more ferromagnetic cups.

29. The method of one of claim 24, 26, 27, or 28, wherein:

providing the at least one magnetic field sensor further comprises:

providing the at least one magnetic field sensor comprising one or more conductors; and

wrapping the one or more conductors around one or more magnets.

30. A method for monitoring usage of electrical power of a structure using an electrical power monitoring system, the structure having one or more main electrical power lines that supply the electrical power to a first load in the structure, the method comprising:

calibrating the electrical power monitoring system, wherein a first raw current in the one or more main electrical power lines and first calibration data are generated while calibrating the electrical power monitor system;

storing the first calibration data and a measurement of the first raw current;

measuring a second raw current;

if the second raw current is not within a predetermined amount of the first raw current, performing a first recalibration of the electrical power monitoring system comprising:

calibrating the electrical power monitoring system, wherein a third raw current in the one or more main electrical power lines and second calibration data are generated while performing the first recalibration of the electrical power monitor system;

storing the second calibration data and a measurement of the third raw current;

and

calculating a first measured current using the second calibration data; and

if the second raw current is within the predetermined amount of the first raw current, calculating the first measured current using the first calibration data; and

displaying the first measured current.

31. The method of claim 30, further comprising:

measuring a fourth raw current;

if the third raw current is not within the predetermined amount of the first raw current or the second raw current, performing a second recalibration of the electrical power monitoring system comprising:

calibrating the electrical power monitoring system, wherein a fifth raw current in the one or more main electrical power lines and third calibration data are generated while performing the second recalibration of the electrical power monitor system;

storing the third calibration data and a measurement of the fifth raw current;

and

calculating a second measured current using the third calibration data;

if the third raw current is within the predetermined amount of the first raw current or the second raw current, calculating the second measured current using the first calibration data or the second calibration data; and

displaying the second measured current.

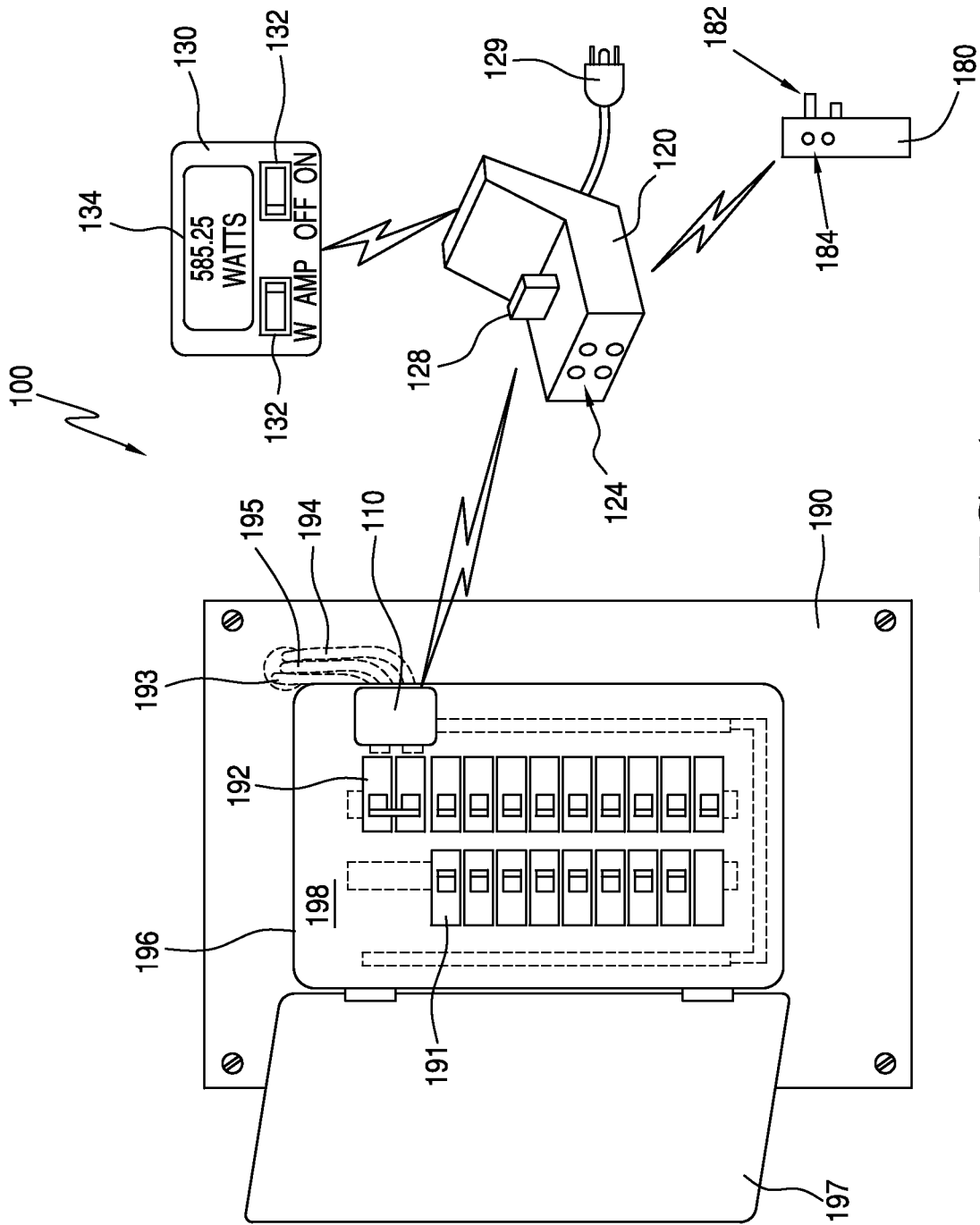

FIG. 1

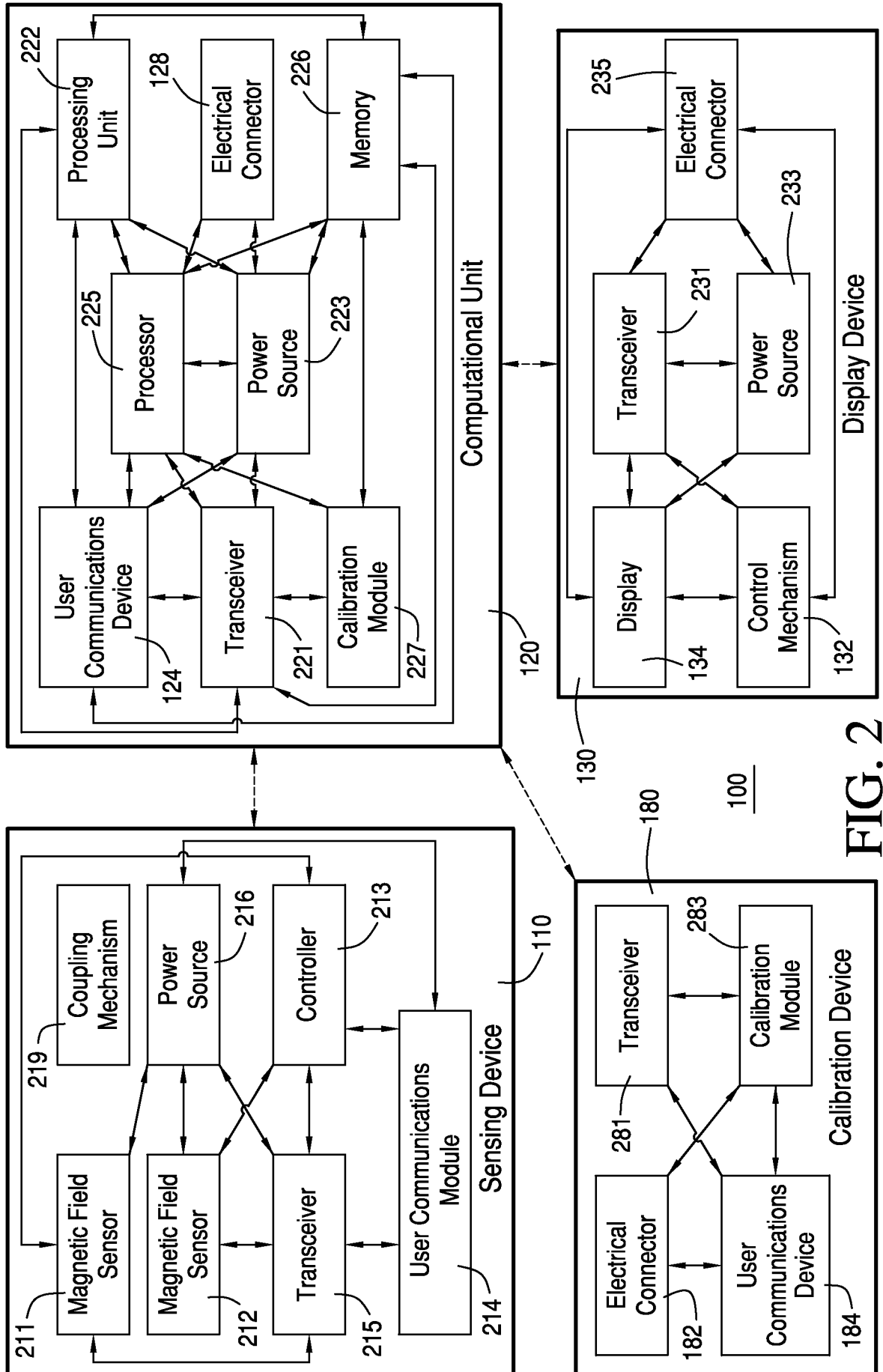

FIG. 2

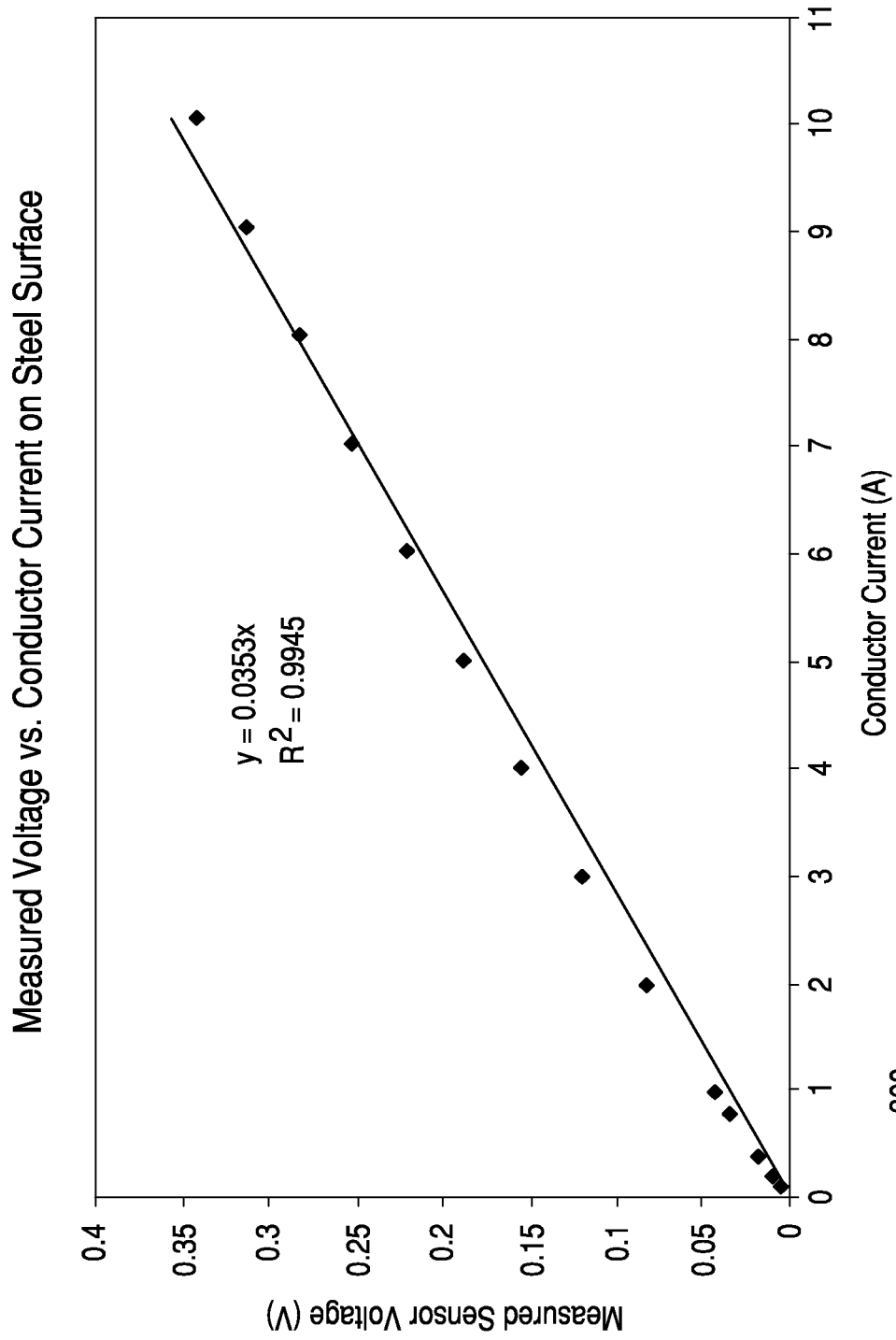

FIG. 3

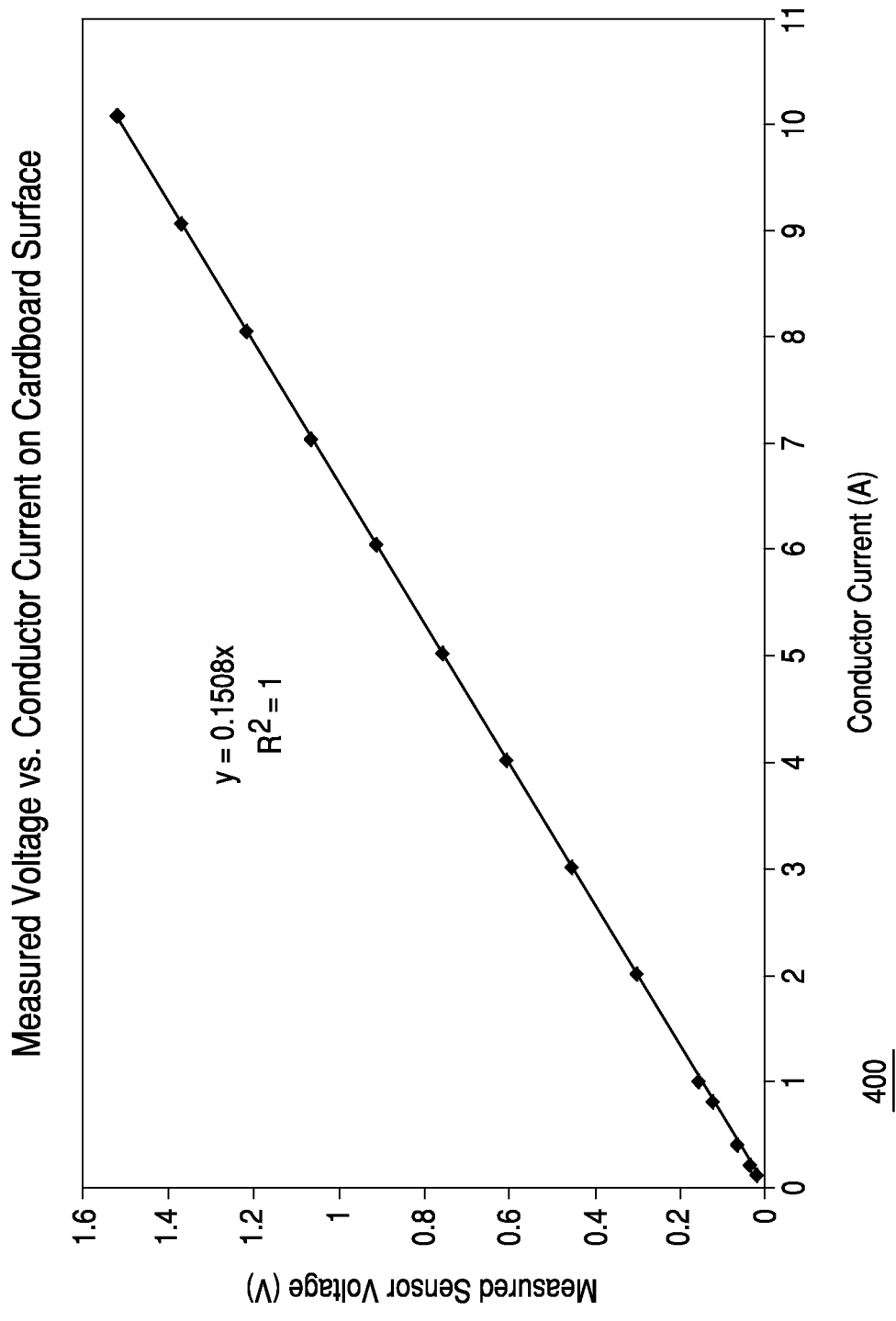

FIG. 4

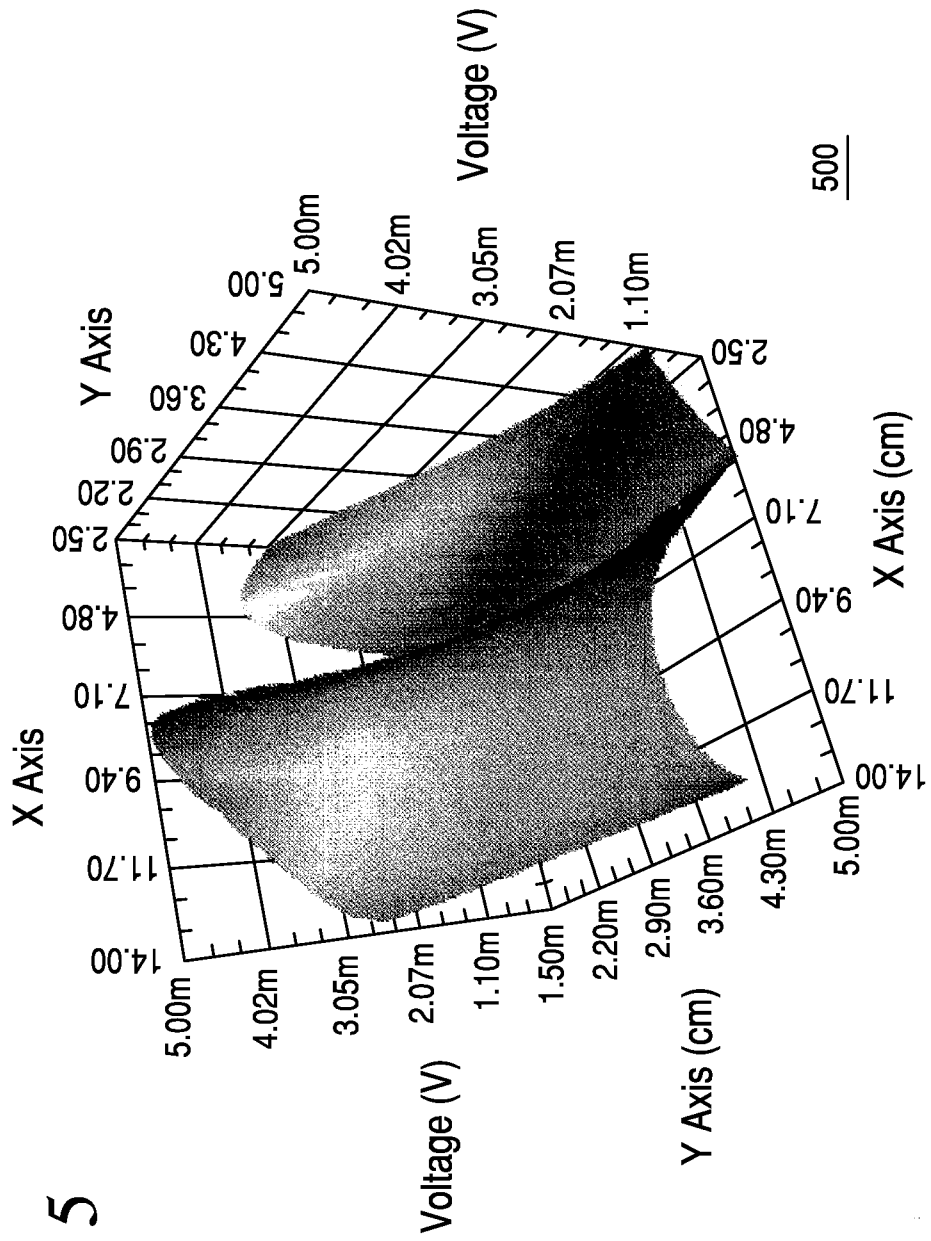

FIG. 5

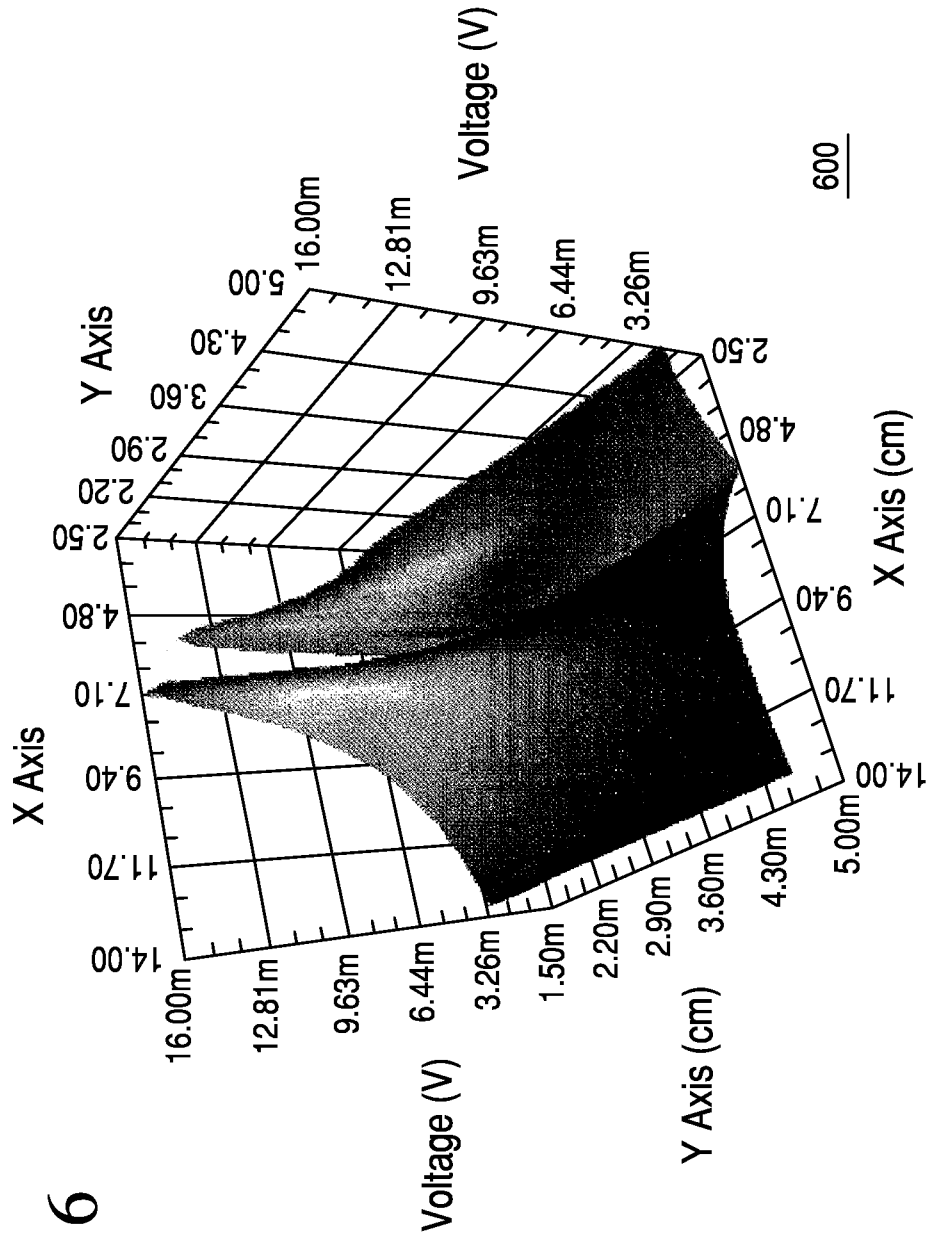
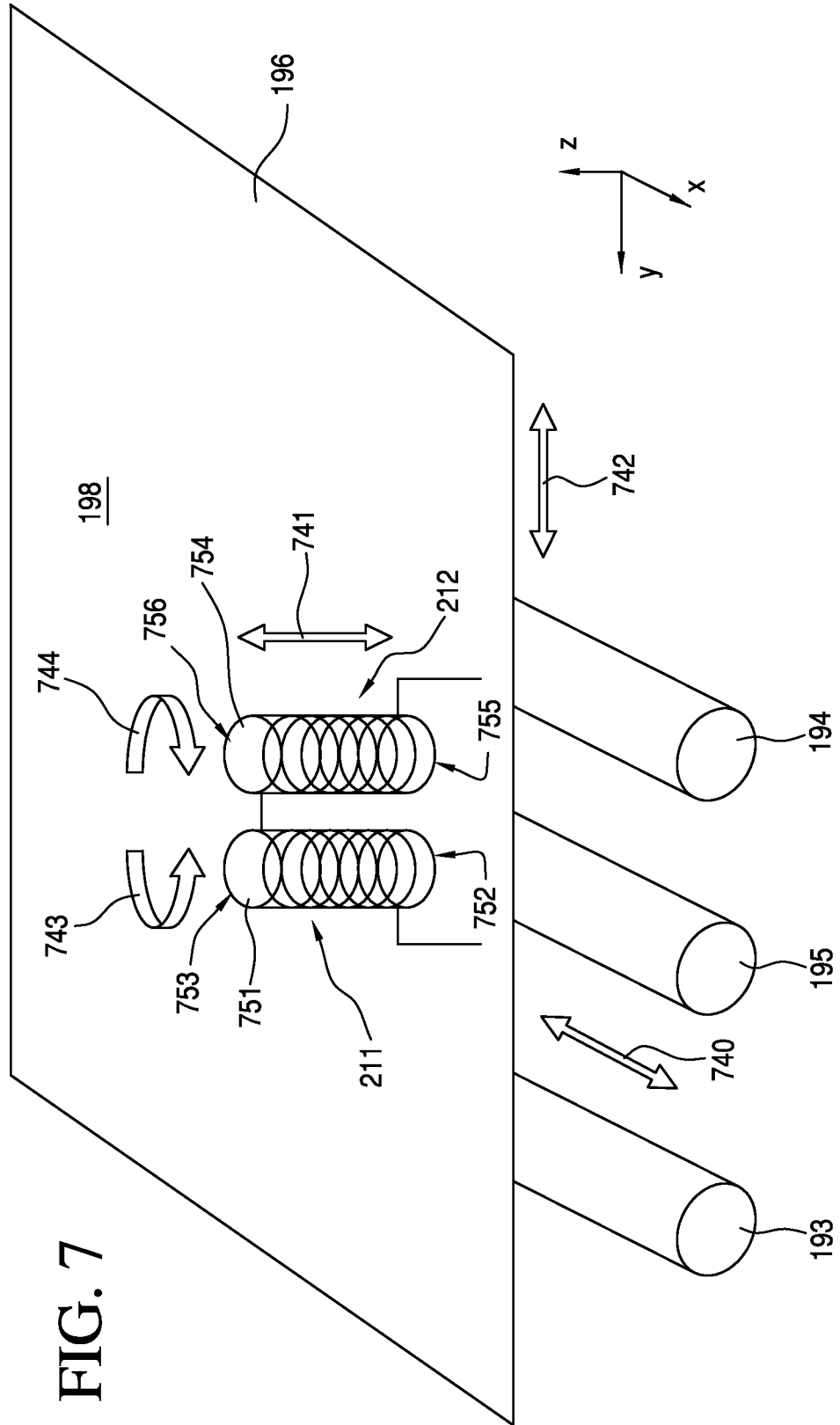

FIG. 6



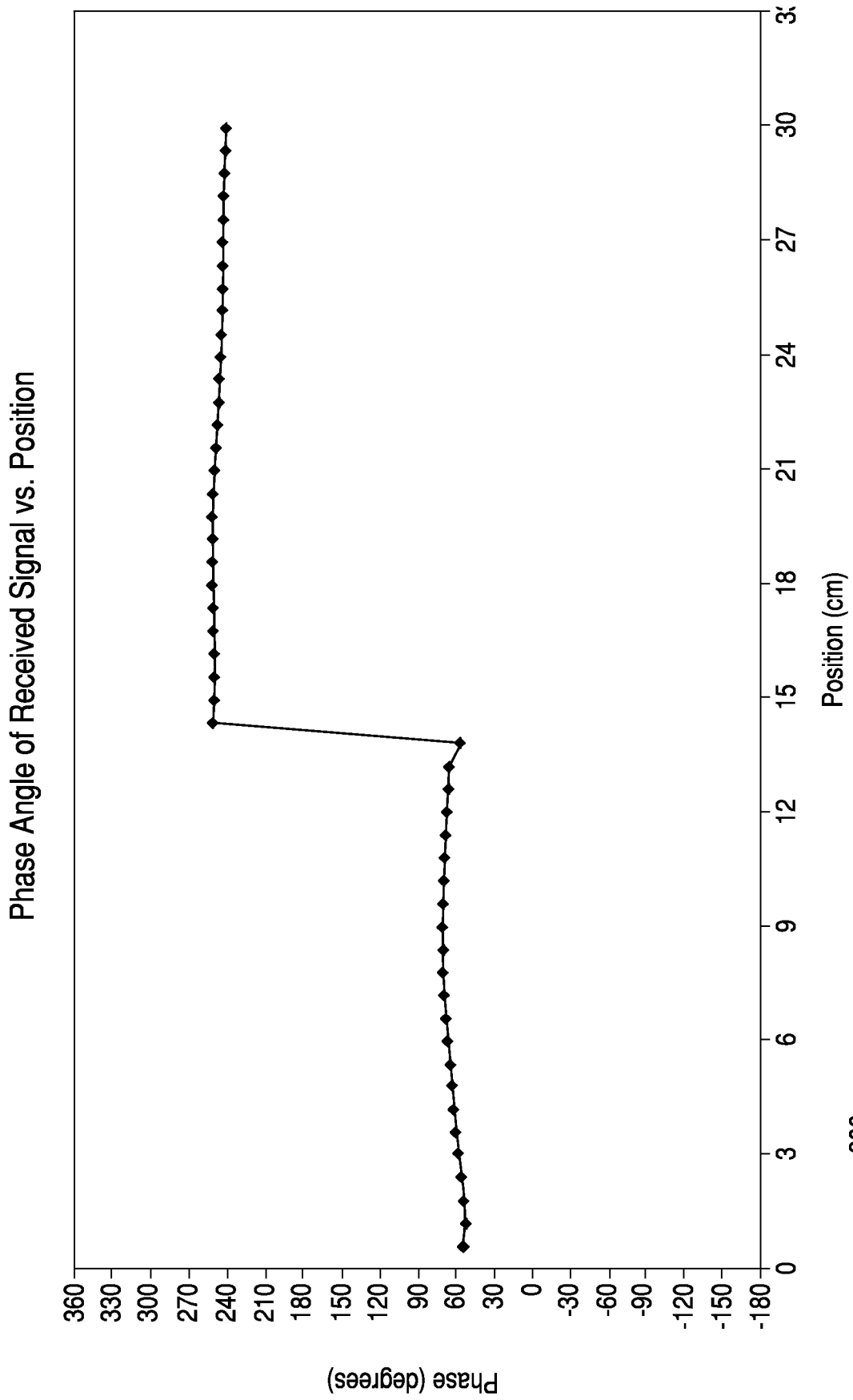

FIG. 8

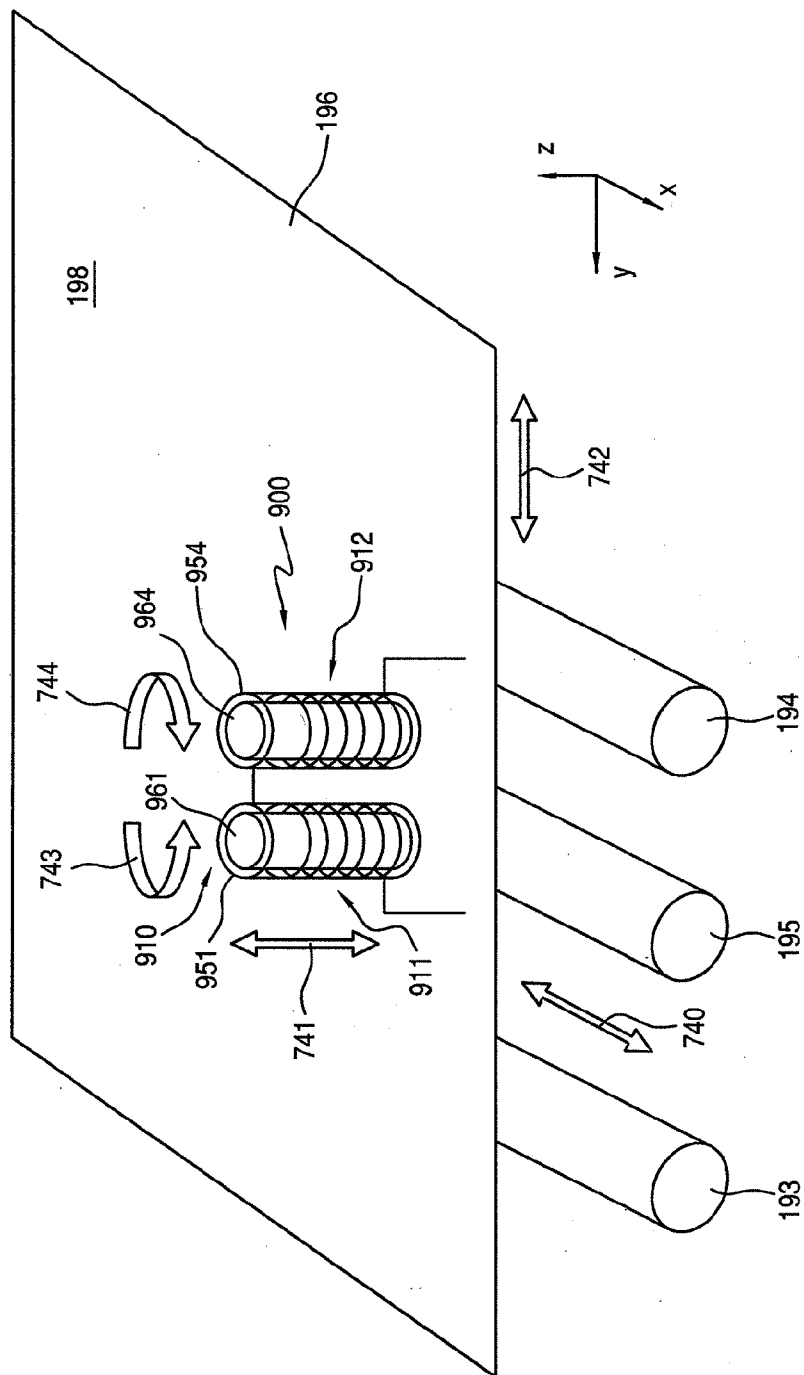

FIG. 9

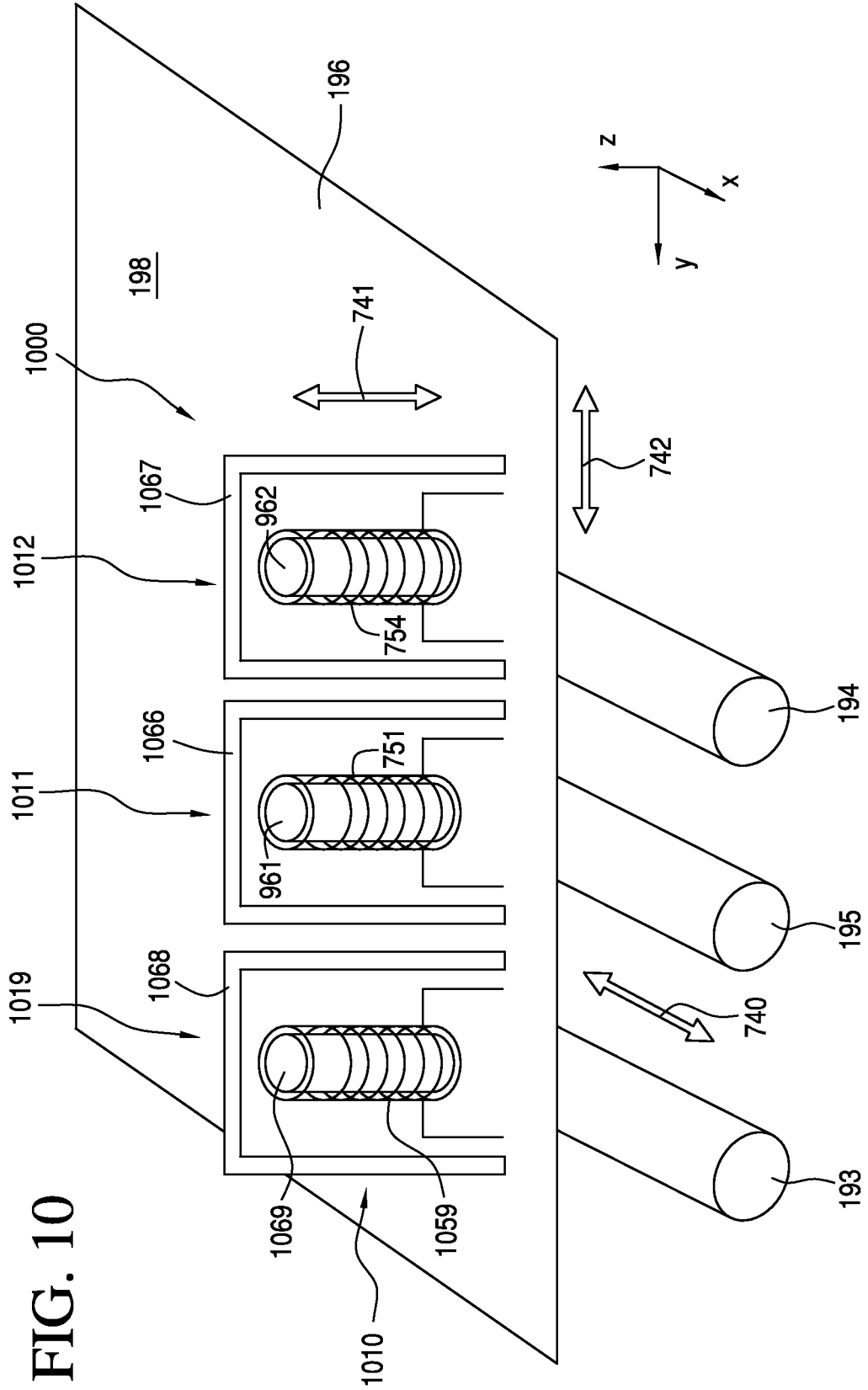
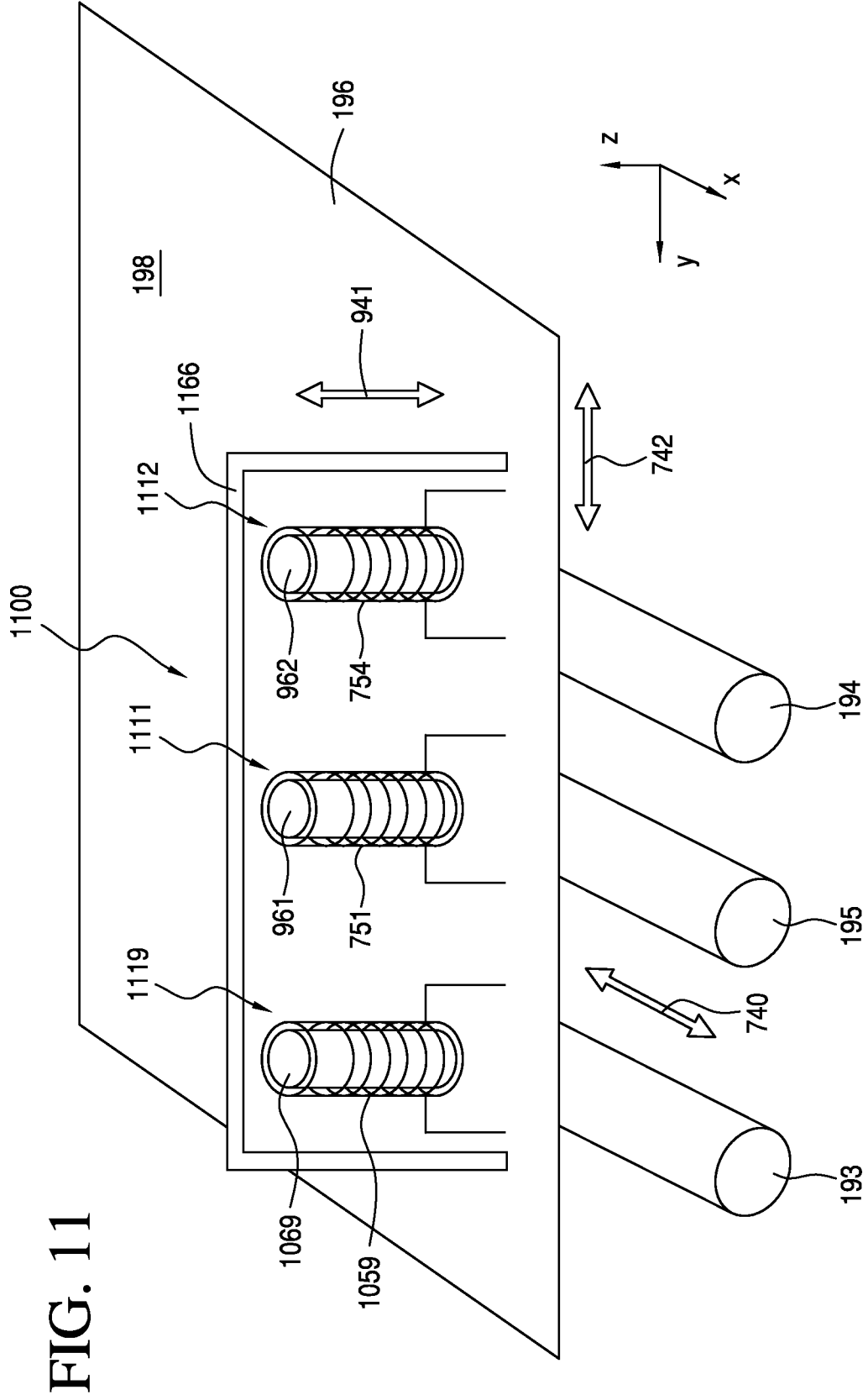
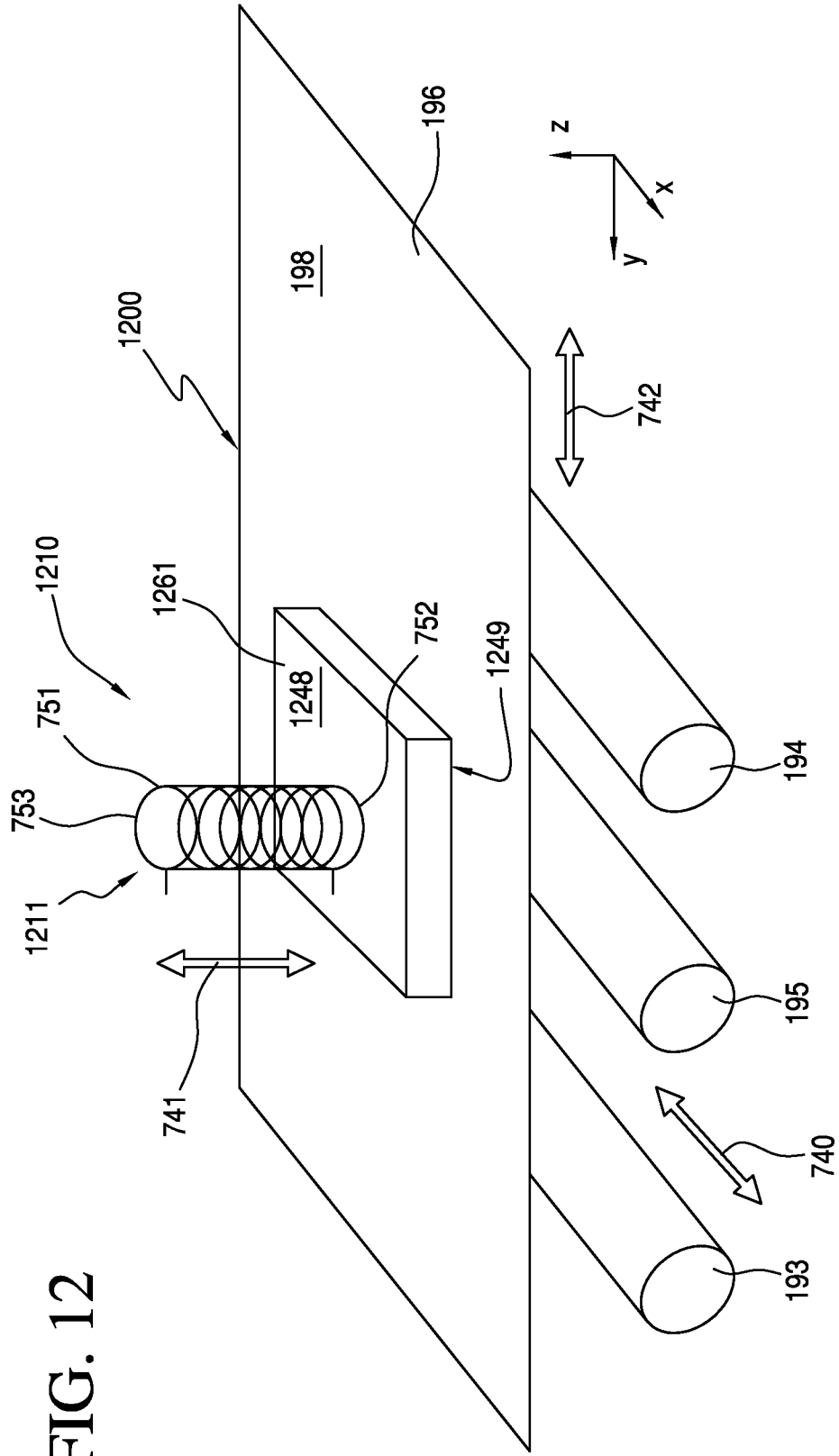
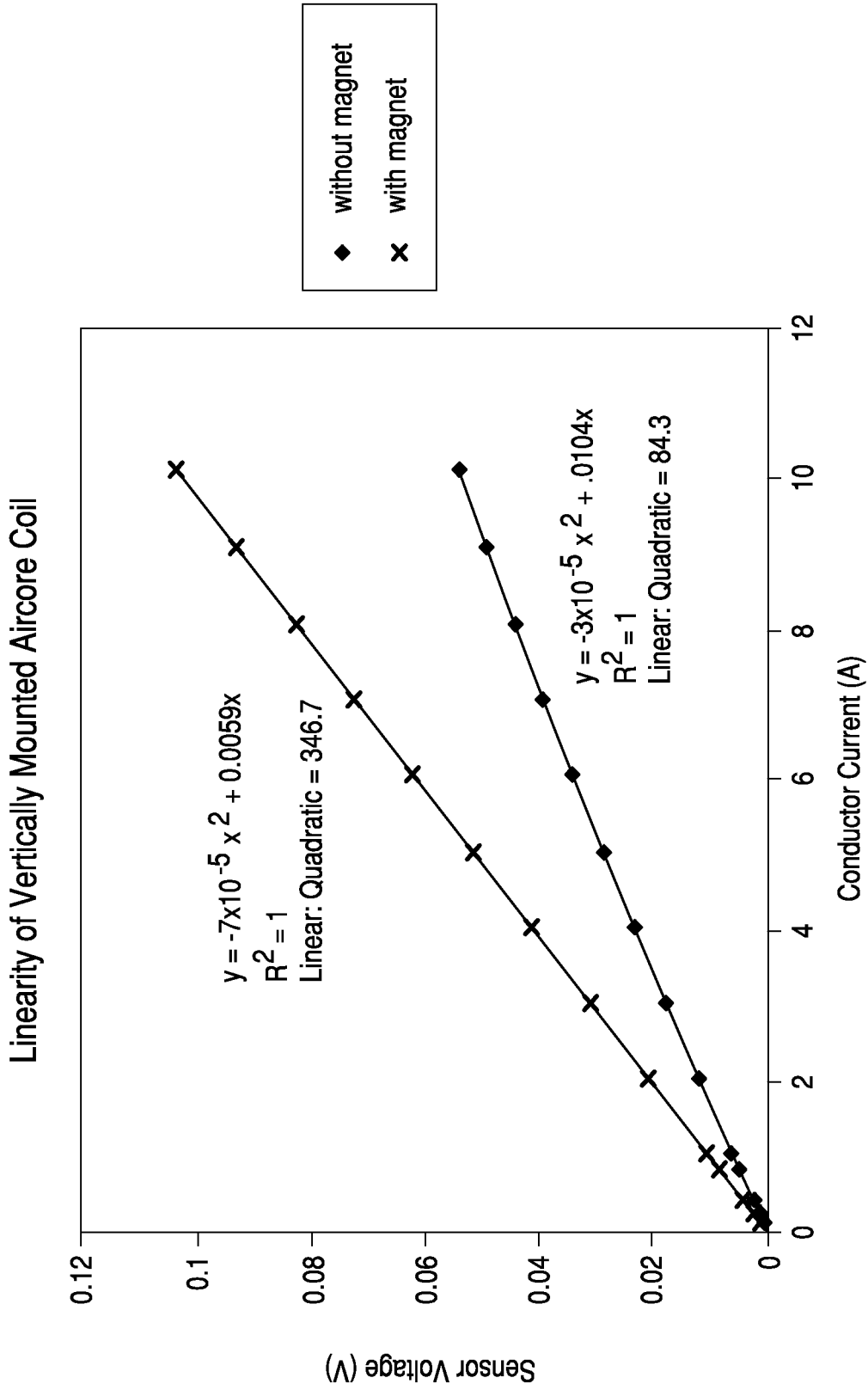

FIG. 10







1300

FIG. 13

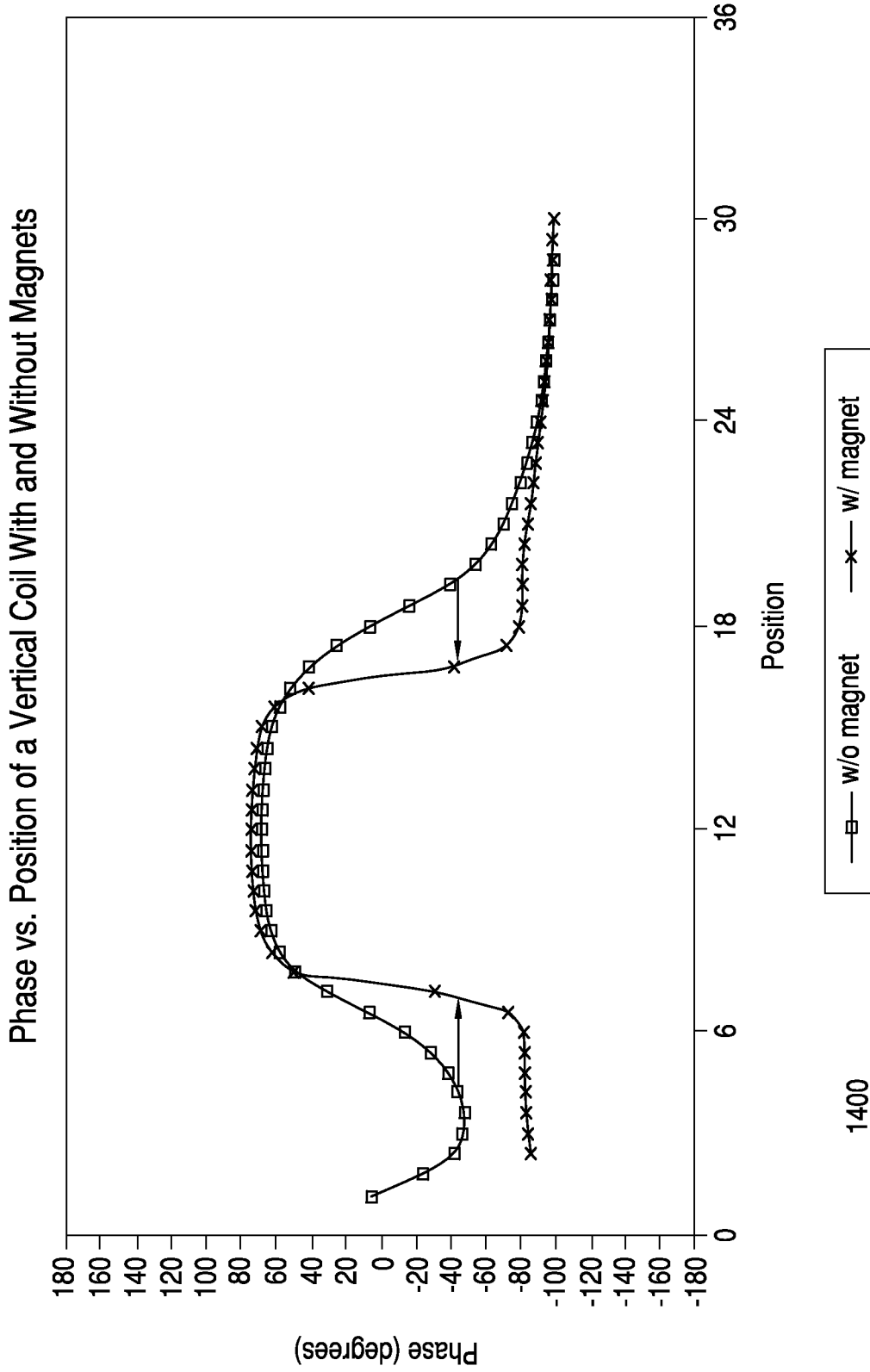

FIG. 14

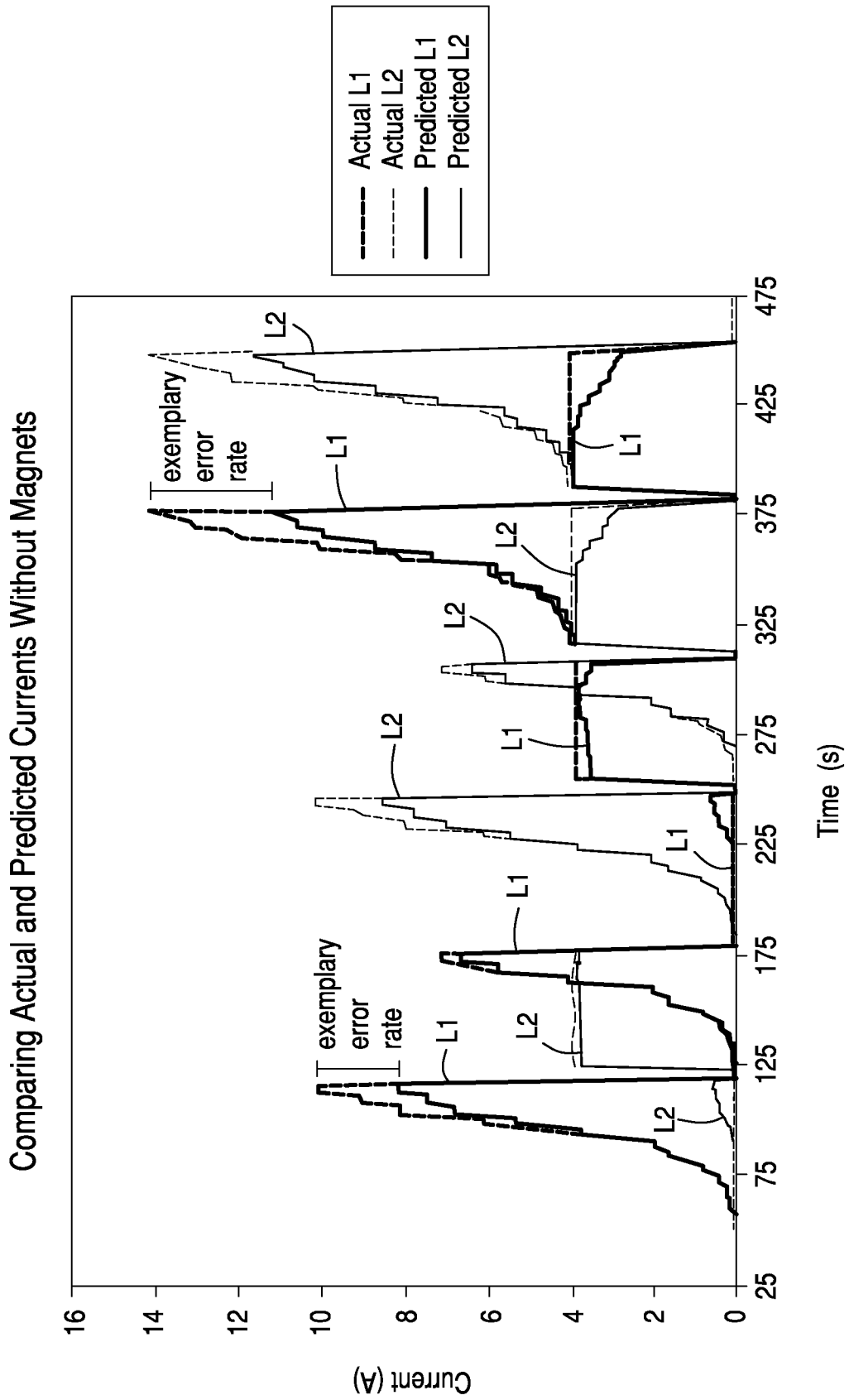

FIG. 15

1500

Comparing Actual and Predicted Currents With Magnets

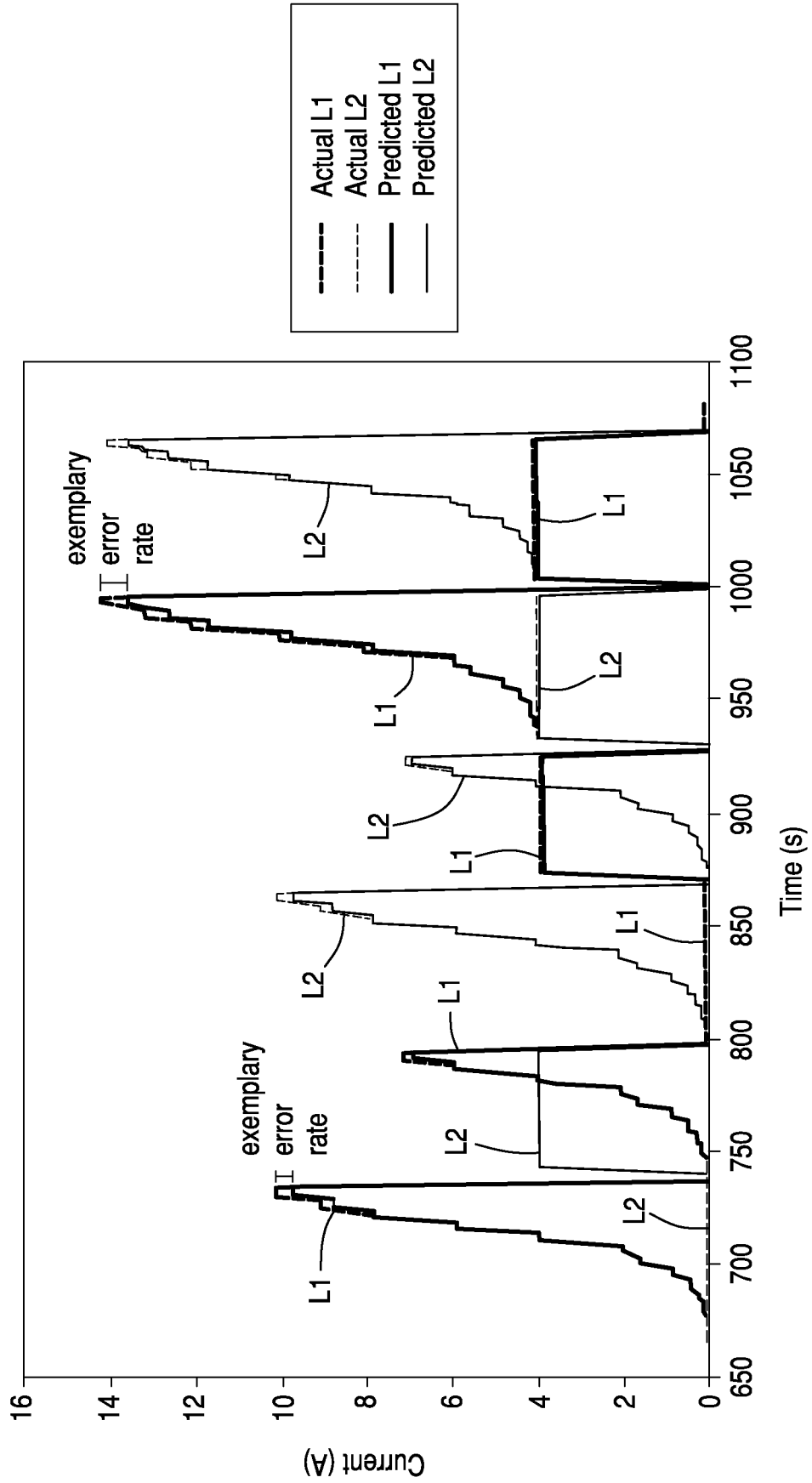
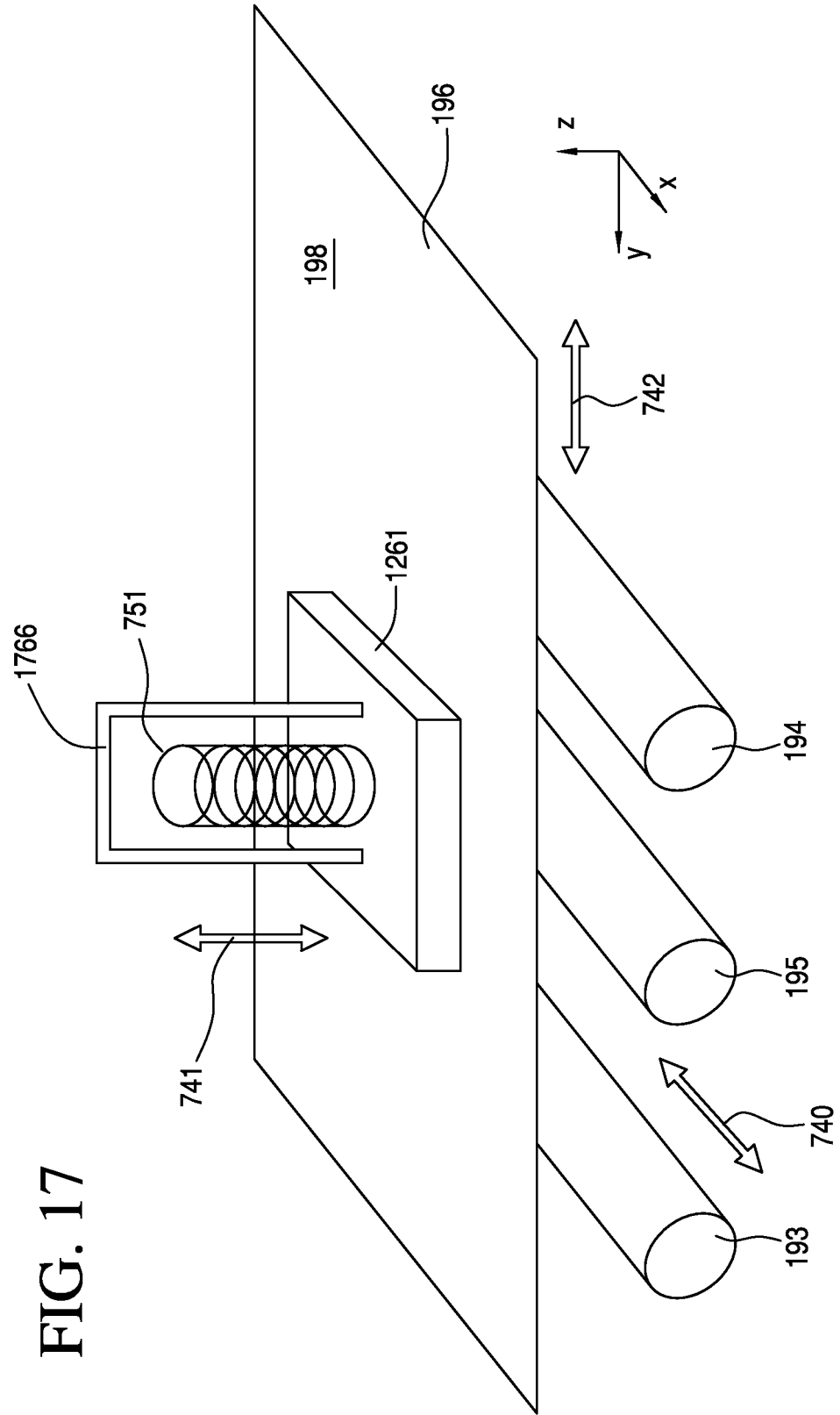

FIG. 16

1600



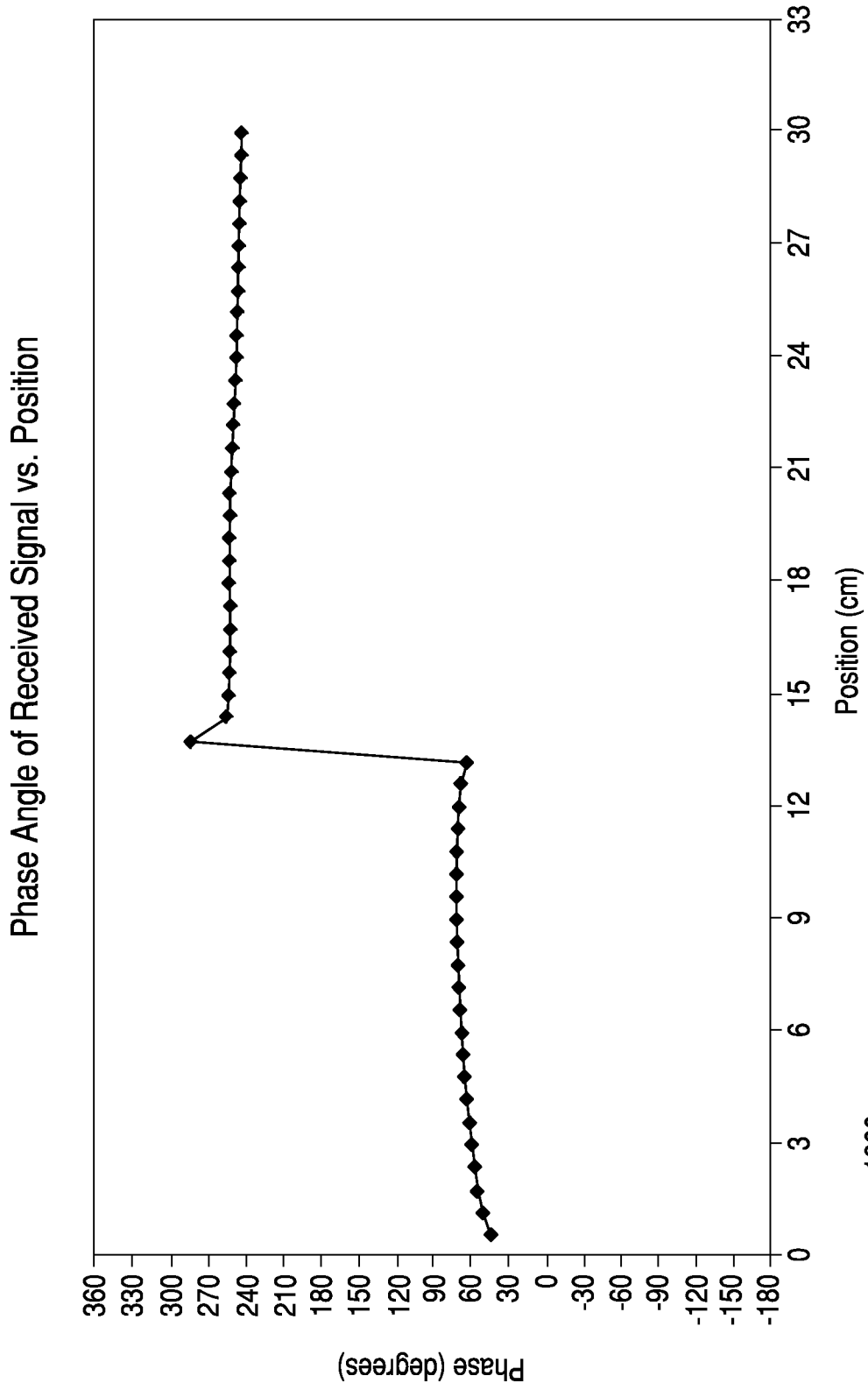

FIG. 19

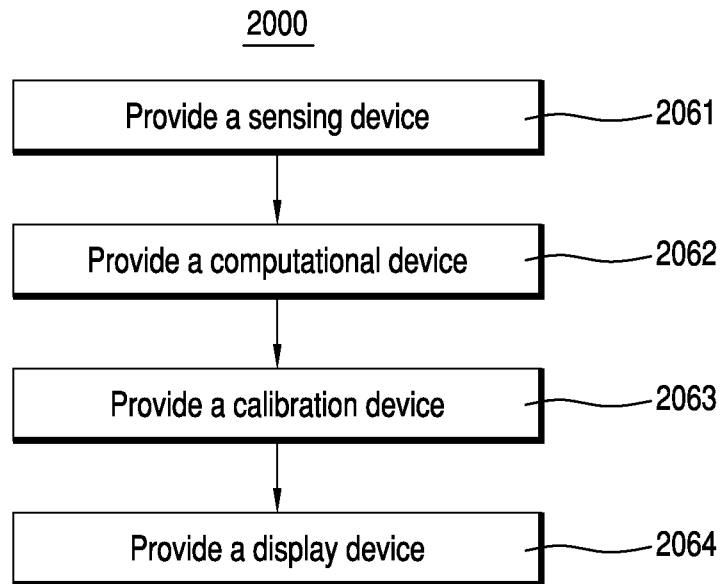

FIG. 20

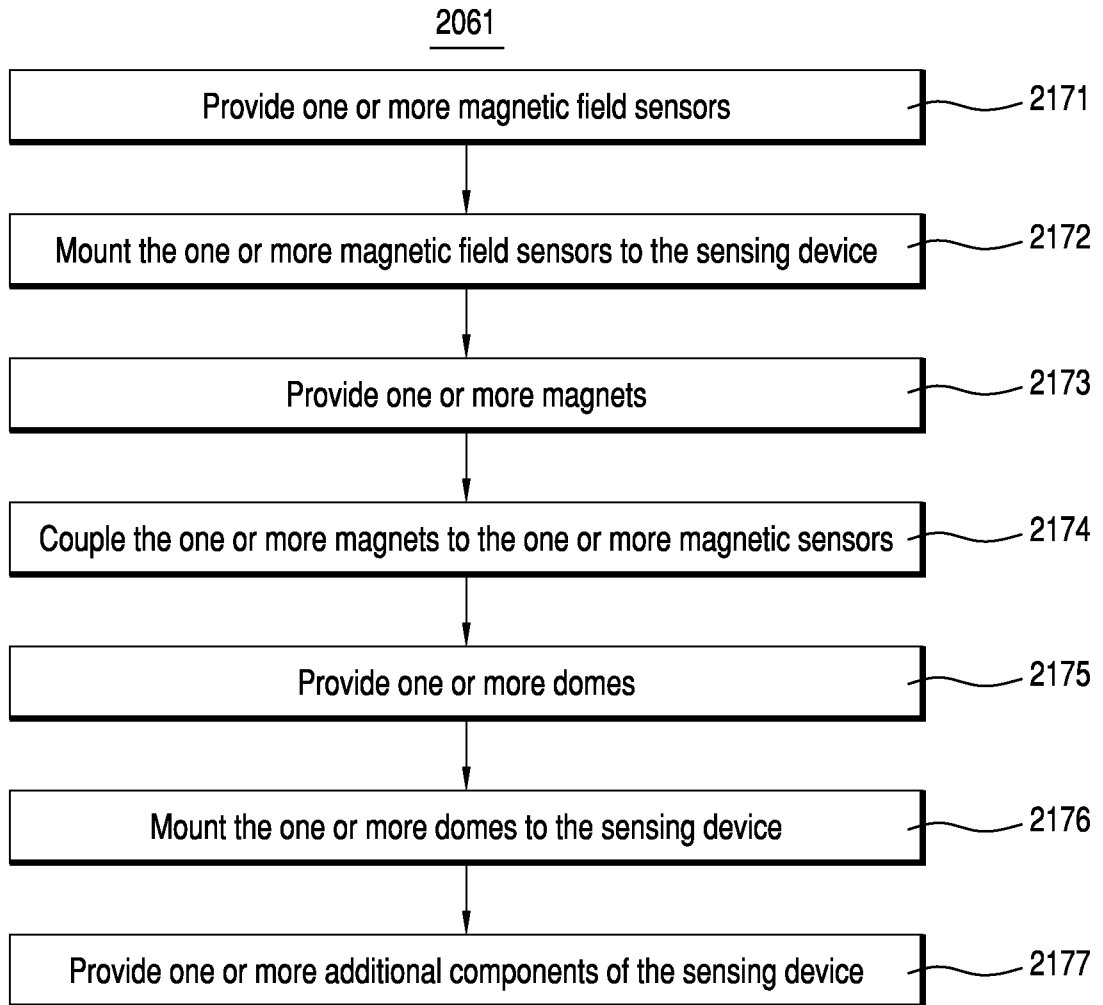

FIG. 21

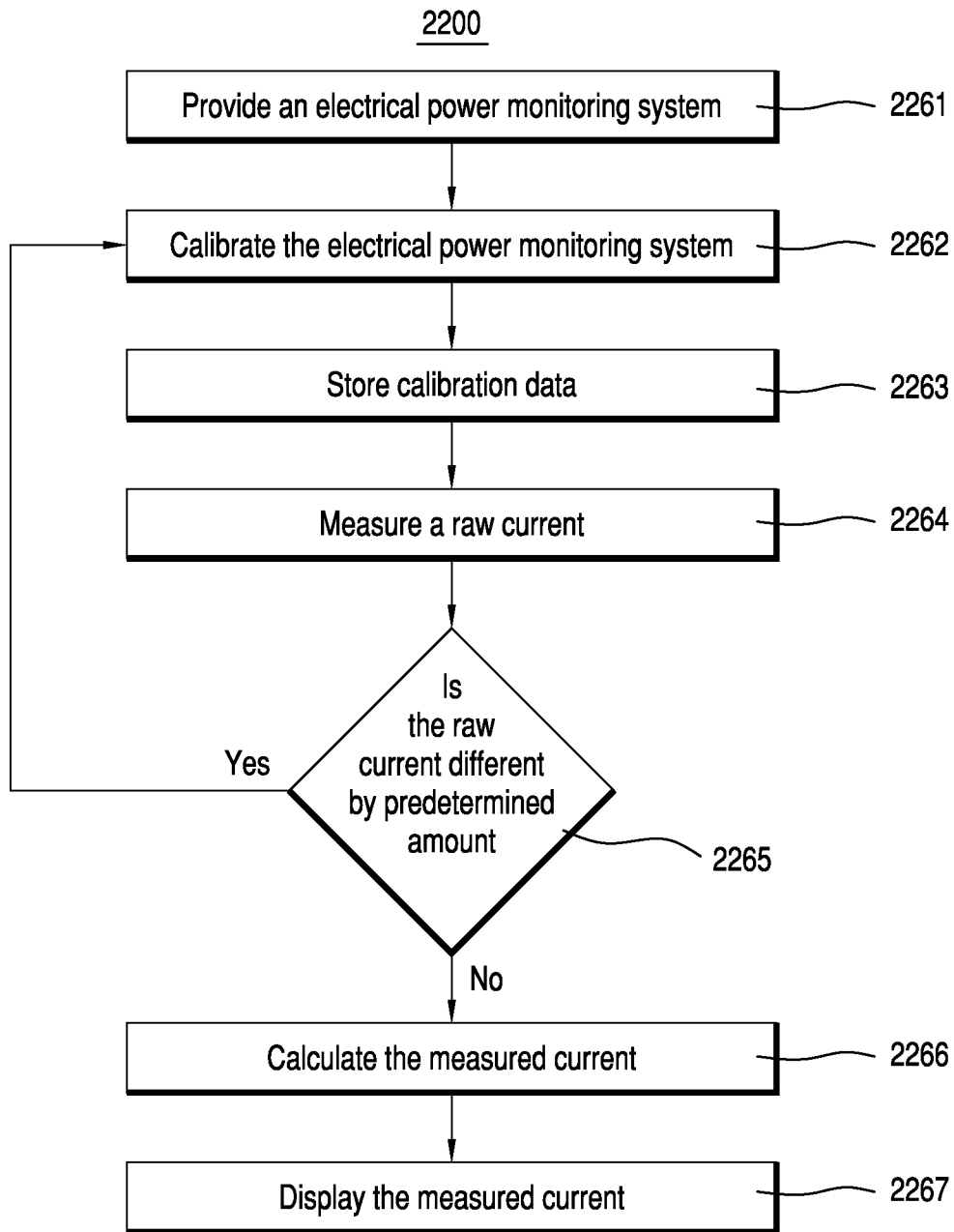

FIG. 22