

(No Model.)

2 Sheets—Sheet 1.

W. C. WINFIELD & J. F. McNUTT.
MACHINE FOR FORMING CORRUGATED ELBOW PIPES.

No. 520,870.

Patented June 5, 1894.

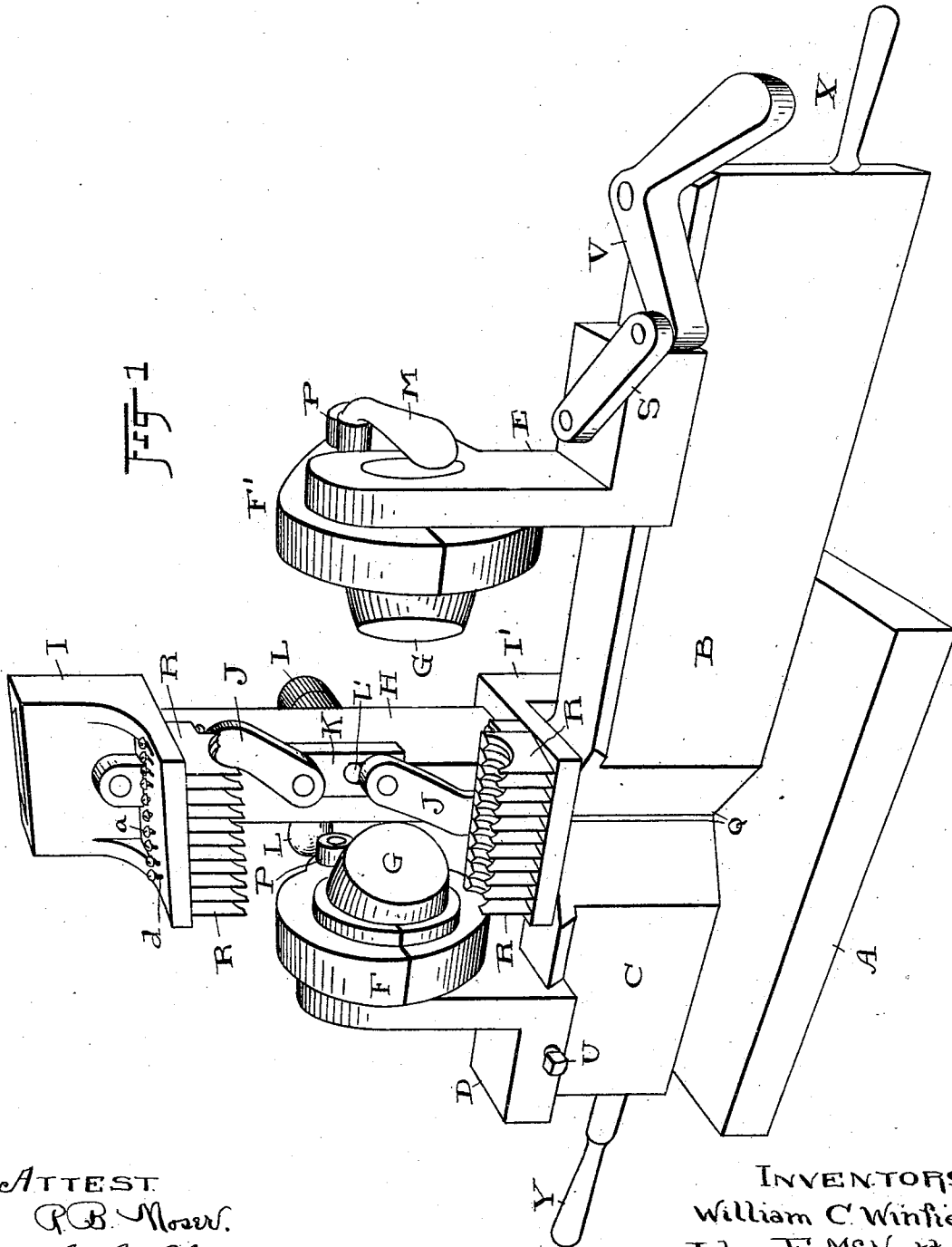

ATTEST
R. B. Moser.
A. S. Schaeffer

INVENTORS
 William C. Winfield
 John F. McNutt
By H. J. Fisher.
 ATTORNEY.

(No Model.)

2 Sheets—Sheet 2.

W. C. WINFIELD & J. F. McNUTT.
MACHINE FOR FORMING CORRUGATED ELBOW PIPES.

No. 520,870.

Patented June 5, 1894.

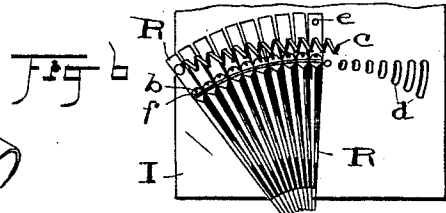
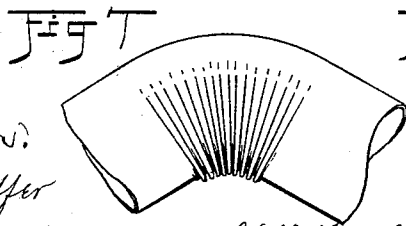
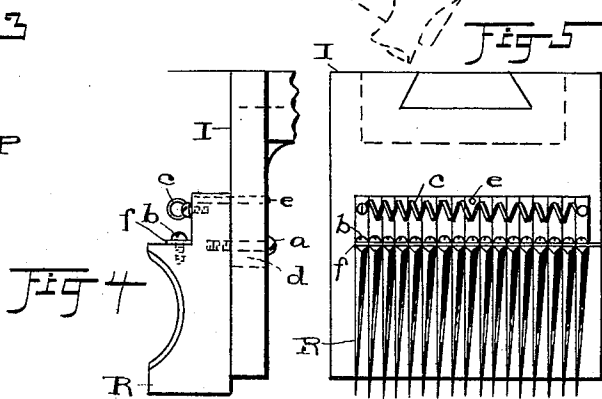
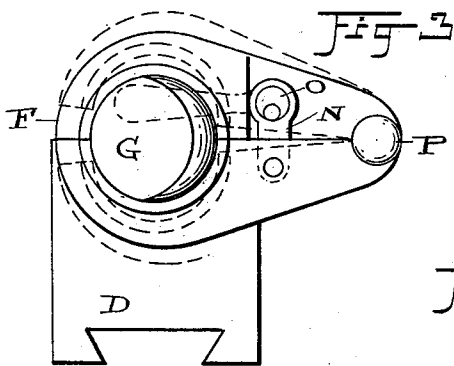
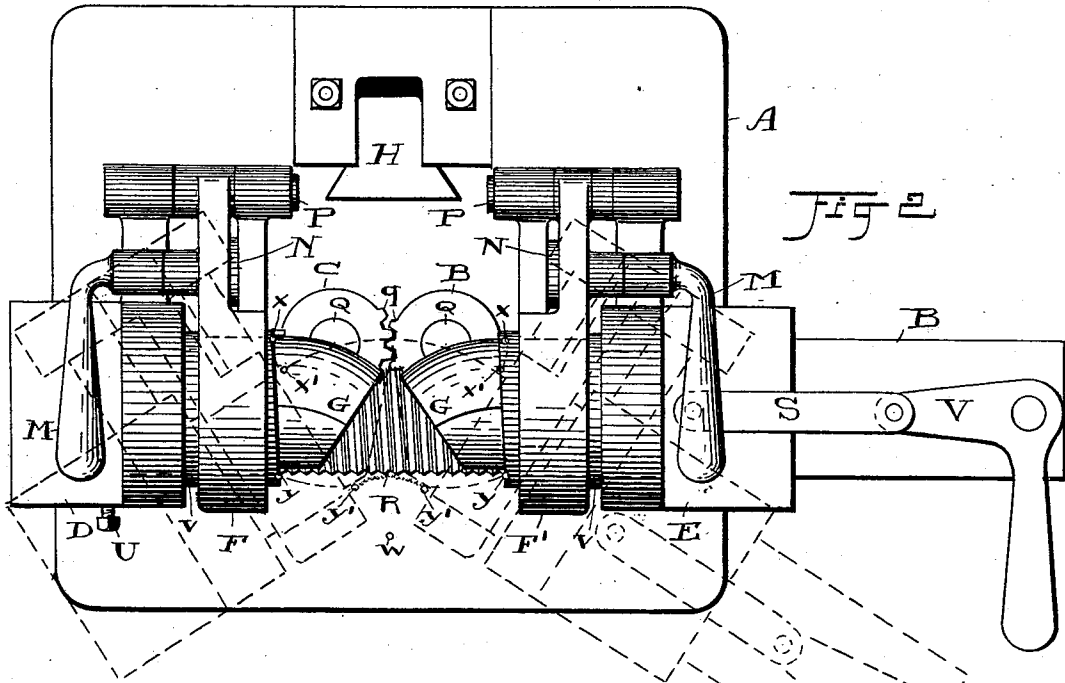

ATTEST.
R. B. Moser
G. S. Schaeffer

By *H. J. Fisher*

INVENTORS.
 William C. Winfield
 John F. McNutt
 ATTORNEY.

UNITED STATES PATENT OFFICE.

WILLIAM C. WINFIELD AND JOHN F. McNUTT, OF WARREN, OHIO, ASSIGNORS TO THE WINFIELD MANUFACTURING COMPANY, OF SAME PLACE.

MACHINE FOR FORMING CORRUGATED ELBOW-PIPES.

SPECIFICATION forming part of Letters Patent No. 520,870, dated June 5, 1894.

Application filed July 12, 1893. Serial No. 480,249. (No model.)

To all whom it may concern:

Be it known that we, WILLIAM C. WINFIELD and JOHN F. McNUTT, citizens of the United States, residing at Warren, in the county of Trumbull and State of Ohio, have invented certain new and useful Improvements in Machines for Forming Corrugated Elbow-Pipes; and we do hereby declare that the following is a full, clear, and exact description of the invention, which will enable others skilled in the art to which it appertains to make and use the same.

Our invention relates to a machine for forming corrugated pipe elbows, and the invention consists in the construction and combination of parts substantially as shown and described and particularly pointed out in the claims.

In the accompanying drawings, Figure 1 is a perspective front elevation of the machine with all the parts in position to receive the pipe to be bent. Fig. 2 is a plan view of the machine with the parts in full lines occupying the position seen in Fig. 1, and with the parts in dotted lines as they appear when a tube is clamped and bent, the upper support and corrugation-clamping sections being removed in this view. Fig. 3 is an elevation of the face of the left hand clamp and mandrel and the support for said parts. Fig. 4 is a view looking in from the right of Fig. 5 and showing a side elevation of one of the corrugation clamping sections and an end view of the support therefor, and the means by which said section is attached to the support. Fig. 5 is a plan view of one of the corrugation-clamping section supports having a full series of said sections affixed thereto and shown in their normal position. Fig. 6 is a plan view of the parts shown in Fig. 5 with the corrugation-clamping sections at the right removed and showing the remaining sections brought together at their points to illustrate their position and relation to one another when bending of the pipe occurs. Fig. 7 is an elevation of an elbow which has been formed by the machine herein described.

It will be understood that if only a slight bend is wanted a fewer number of corrugation or forming sections will be used, but if a full right angle bend be wanted and the pipe is comparatively large, there would prob-

ably be twelve or fifteen or more of said sections employed. As many may be used as the work requires.

A represents a flat rectangular bed plate upon which is mounted the upright guide-post H, rigid with the rear of the said bed plate and serving more especially as a support and guide for the oppositely moving supports I, I', which carry the clamping sections R. These supports I, I' are intended to move freely toward and from one another and to move in unison, and to this end are connected by links J to the ends of the crank arm K, rigidly affixed to a spindle passing through the post H and provided with a handle L. It will be noticed, however, that the lower link J has its pivot point nearer to the spindle L' of the crank than the upper link J so that when the said crank is turned the upper support I will travel farther than the lower support I'.

Upon the base A are pivoted at Q, Q, Fig. 2, the swinging beams or levers B and C, which are provided respectively with handles X and Y at their ends. The mandrels G are mounted on the swinging beams by means of the brackets E and D, to which the mandrels or cores G are rigidly affixed. These mandrels or cores are slightly bent, as clearly seen in Fig. 2, and have their free inner ends beveled so as to adapt the parts to bend the pipe and at the same time support it all around as will hereinafter more clearly appear. The bracket D is adjustable back and forth upon the beam or lever C and is secured in any given place of adjustment by means of the set screw U, and is moved only to adapt the bracket to different lengths of pipe, some pipes having a length beyond the corrugation greater than others. The bracket E likewise is supported upon its beam B to be moved back and forth in respect to the opposite bracket and mandrel, and is controlled by means of a crank lever V and a link S so as to be readily moved or adjusted when it is desired to insert a pipe section or to remove the same after it has been bent.

The clamps F and F' are formed in two sections, each having a common pivot P and encircling the mandrels or cores G about their base, and are adapted to be opened when a

pipe is introduced, and then to be clamped upon the pipe to firmly hold the same or bend it, after which they are again opened to remove the pipe and insert another. As a means of opening and closing said clamps, we have here shown a link N, Fig. 3, secured to one of said clamping sections near its middle length and a crank handle M with an eccentric O passing through the other section of the clamp and the said link. Hence, when the said handle is turned in one direction, it will open the clamps, and when turned in the other direction, it will firmly close them upon the pipe and mandrel. The construction of the two clamps F and F' is alike, and the parts thereof are designated by like letters. Immediately back of said clamps at the base of the cores or mandrels are shoulders or collars —v— which serve as buttons or stops for the pipe, and when the pipe is placed in position its ends abut against these collars and the clamps F and F' are then fastened thereon and the parts are in position to be turned to bend the pipe.

To encircle the pipe and fit in the corrugations thereof, which have been previously made, for the purpose of controlling the formation of the same in the process of bending, we provide the tapering segmental corrugation clamping sections R. These sections are arranged in two sets which come at opposite sides of the corrugated portion of the pipe and are designed to meet in the throat of the pipe. It will be noticed that they are not only separate from one another or formed in separate pieces, but that they taper along both sides from base to point, the exact construction thereof being disclosed clearly in Figs. 4 and 5, Fig. 4 showing a side view and Fig. 5 an edge view with the said clamps separated at their points and in position to enter the corrugations of the pipe when the pipe is placed in the machine. Each series or set of said sections R is attached to its support I or I', and the construction of these supports and the parts connecting the said sections thereto is substantially alike in all particulars. Each section is attached to its support by means of a screw —a—, which passes through the support into the section, and the screw serving also as a pivot point. In order that the said sections R may assume the proper position to adapt them to the corrugations in the throat of the pipe when the bending occurs, it is necessary that they should be so attached to their supports as to be movable toward a given center at their reduced ends, the relation or position which they take when this occurs being shown in Fig. 6. Hence we have formed slots or openings —d— through the supports I and I', which said slots are made longest on the outside and are shortened toward the center in proportion to the distance the respective sections R have to move in order to assume the position corresponding to that in Fig. 6. The screws —a— are inserted through these slots and the parts

are not so firmly fastened but that the sections R have freedom to move back and forth. The middle section R of each set is fastened by a dowel pin —e— or its equivalent so as to be rigid upon its support and the other sections move to and from it on the sides. In order that the said sections may all be thrown back into their normal position after use, we connect the end sections by means of a spiral spring —c—, or its equivalent, which operates to spread the sections, as seen in Fig. 5, and then in order to keep said sections properly aligned we employ a flexible strip —f— which is affixed to the shoulders of the sections by means of a small screw —b—. Obviously, any equivalent means for maintaining alignment and to keep the said sections in the relation shown in Fig. 5 may be adopted. As the middle section R of each set is rigid, when the parallel portion at the heel of each section is brought in line with the adjoining section by means of the spring —c—, all the sections must necessarily be in line and proper position.

To get the proper bending or closing in the inside or throat of the elbow without subjecting the tapering side or seam to any pull or stretch due to such closing or bending of the pipe, the mandrels and the clamps F and F' are mounted upon swinging beams which are pivoted at such a point as will control the positions of the ends of the elbow and insure a proper position throughout the entire process of bending; that is, taking the points —x—, —x— and —x'—, —x'— and the points —y—, —y— and —y'—, —y'— at either end of the corrugated portion, the points —x—, —y— and —x—, —y— at the two sides would designate the position of the points before bending, while during the process of bending these points would follow their respective curves, shown by the dotted lines, until they arrive at the positions of full bending, indicated in this instance by —x'—, —y'— and —x'—, —y'—. These points being considered in their relation to the prime center —w— of the curve of the elbow are found to assume a correct position and to have described arcs whose centers are common with the centers of pivots Q, Q of the beams B and C, which likewise have been moved in bending, as seen by dotted lines Fig. 2. A still greater angle of bending may be given to the pipe than that here indicated, but the operation in any case, whether the bending be greater or less, will be the same as described.

To insure concerted action of the beams or levers B and C they are provided with hubs or their equivalents at or about their pivots Q, Q, on which are teeth —g— adapted to mesh together and thus cause the said beams to move in unison. The inner ends of the cores or mandrels G are so arranged in respect to one another as to extend into the pipe to near the center thereof, and their curvature or bending is such as corresponds to the shape of the elbow when bent, the product

of the machine and the result of its operation being illustrated in Fig. 7.

The operation is as follows: The clamp F is opened by turning the handle M and its eccentric O a half revolution backward, when the mandrel is free to slip the pipe over against the shoulder —v—, and the left hand clamp is closed by reverse movement of the lever M and the pipe is fastened at that end. Then the right hand mandrel and clamp are moved back to introduce the other end of the pipe over this mandrel and to fasten the clamp F' thereon. This being done the handle lever L which controls the two supports I and I' and their corrugation clamping sections is given a half revolution to the right which throws the crank K and the connections or links J into a closed position and brings the clamping sections down into the corrugations of the pipe and holds them firmly therein for the further operation of bending. The handles X and Y upon the beams or levers B and C are then grasped and the said beams are swung upon their pivots Q into the position shown, for example, in dotted lines in Fig. 2, and in this operation compressing the corrugated portion of the pipe especially in the throat thereof and imparting to the pipe the desired bend. All this is the work of but a few moments, and when the bending is effected the clamping sections are withdrawn by turning the lever L, the right hand clamp F' is opened and the bracket E withdrawn and the left hand clamp F is opened and the finished elbow removed.

Having thus described our invention, what we claim as new, and desire to secure by Letters Patent, is—

1. A machine for bending corrugated pipe, comprising two cores or mandrels upon which the pipe to be bent is placed, said mandrels mounted upon separate swinging beams or levers, the adjustable clamping sections adapted to engage the corrugations of the pipe, the oppositely moving supports for the same and means to operate said supports, substantially as set forth.

2. A machine for bending corrugated pipe, comprising two cores or mandrels upon which the pipe to be bent is placed, said mandrels mounted upon and swinging with pivoted beams or levers having independent pivots or centers and moving in unison, the adjustable clamping sections adapted to engage the

corrugations of the pipe, and the oppositely moving supports for the same, substantially as set forth.

3. In the machine described, the combination of the two cores or mandrels upon which the pipe to be bent is placed, with the swinging beams or levers carrying said mandrels one beam driving the other and having independent pivots or centers, substantially as set forth.

4. The combination of the mandrels upon which the pipe is to be bent, with the supports for said mandrels adjustable on the swinging beams or levers carrying said supports and mandrels and one beam driving the other, substantially as set forth.

5. In combination with the mandrels, the two independently pivoted beams carrying the mandrels and having gears at their hubs about their pivots meshing together and serving to cause said beams to move in unison, substantially as set forth.

6. The combination of the cores or mandrels with the clamps encircling said mandrels for holding the tube, and eccentrics and links for opening and closing said clamps, substantially as set forth.

7. The combination of the corrugation-clamping sections, the supports for the same having a groove adapted to move upon a slide in opposite directions and means for operating said supports, substantially as set forth.

8. The corrugation-clamping sections, in combination with the oppositely moving supports therefor, said supports having groove openings in their faces through which the clamping sections are independently and movably attached thereto, substantially as set forth.

9. The oppositely moving supports having openings through which the corrugation-clamping sections are attached, in combination with a series of clamping sections, one of said sections being rigid with its support and the others movable on said support, substantially as set forth.

Witness our hands to the foregoing specification.

WILLIAM C. WINFIELD.
JOHN F. McNUTT.

Witnesses:

C. D. CARLISLE,
W. F. LANE.