

REPUBLIC OF SOUTH AFRICA
PATENTS ACT, 1978

(To be lodged in duplicate)

PUBLICATION PARTICULARS AND ABSTRACT

(Section 32(3)(a) - Regulations 22(1)(g) and 31)

REFERENCE : AP37704ZA00

OFFICIAL APPLICATION NO.	LOGGING DATE	ACCEPTANCE DATE
21 2004/3758	22/23 17 May 2004	43 23-11-2004

INTERNATIONAL CLASSIFICATION	NOT FOR PUBLICATION
51 B67D	CLASSIFIED BY :

FULL NAME(S) OF APPLICANT(S)
71 FLEXTAINER S.A.

FULL NAME(S) OF INVENTOR(S)
72 ROSER, Philippe

EARLIEST PRIORITY CLAIMED	COUNTRY	NUMBER	DATE
NOTE : The country must be indicated by its International Abbrevlation - see Schedule 4 of the Regulations.	33 FR	31 01/15274	32 26 November 2001

TITLE OF INVENTION
54 LIQUID DISPENSING TAP

57 ABSTRACT (NOT MORE THAN 150 WORDS)	NUMBER OF PAGES
	22

FOR ABSTRACT SEE THE NEXT SHEET

(12) DEMANDE INTERNATIONALE PUBLIÉE EN VERTU DU TRAITÉ DE COOPÉRATION
EN MATIÈRE DE BREVETS (PCT)(19) Organisation Mondiale de la Propriété
Intellectuelle
Bureau international(43) Date de la publication internationale
5 juin 2003 (05.06.2003)

PCT

(10) Numéro de publication internationale
WO 03/045833 A1

- (51) Classification internationale des brevets⁷: B67D 3/04 (72) Inventeur; et
(75) Inventeur/Déposant (pour US seulement): ROSEY,
Philippe [FR/FR]; 31, rue de la Gare, F-67330 Dossen-
heim-sur-Zinsel (FR).
- (21) Numéro de la demande internationale :
PCT/FR02/04037 (74) Mandataire : CABINET NUSS; 10, rue Jacques Kablé,
F-67080 Strasbourg Cedex (FR).
- (22) Date de dépôt international :
25 novembre 2002 (25.11.2002)
- (25) Langue de dépôt : français (81) États désignés (national) : AE, AG, AL, AM, AT, AU, AZ,
BA, BB, BG, BR, BY, BZ, CA, CH, CN, CO, CR, CU, CZ,
DE, DK, DM, DZ, EC, EE, ES, FI, GB, GD, GE, GH, GM,
HR, HU, ID, IL, IN, IS, JP, KE, KG, KP, KR, KZ, LC, LK,
LR, LS, LT, LU, LV, MA, MD, MG, MK, MN, MW, MX,
MZ, NO, NZ, OM, PH, PL, PT, RO, RU, SD, SE, SG, SI,
SK, SL, TJ, TM, TN, TR, TT, TZ, UA, UG, US, UZ, VC,
VN, YU, ZA, ZM, ZW.
- (26) Langue de publication : français (84) États désignés (régional) : brevet ARIPS (GH, GM, KE,
LS, MW, MZ, SD, SL, SZ, TZ, UG, ZM, ZW), brevet
- (30) Données relatives à la priorité :
01/15274 26 novembre 2001 (26.11.2001) FR
- (71) Déposant (pour tous les États désignés sauf US) : FLEX-
TAINER S.A. [FR/FR]; Zone Industrielle, F-57370 Schal-
bach (FR).

[Suite sur la page suivante]

(54) Title: LIQUID DISPENSING TAP

(54) Titre : ROBINET DE DISTRIBUTION DE LIQUIDES

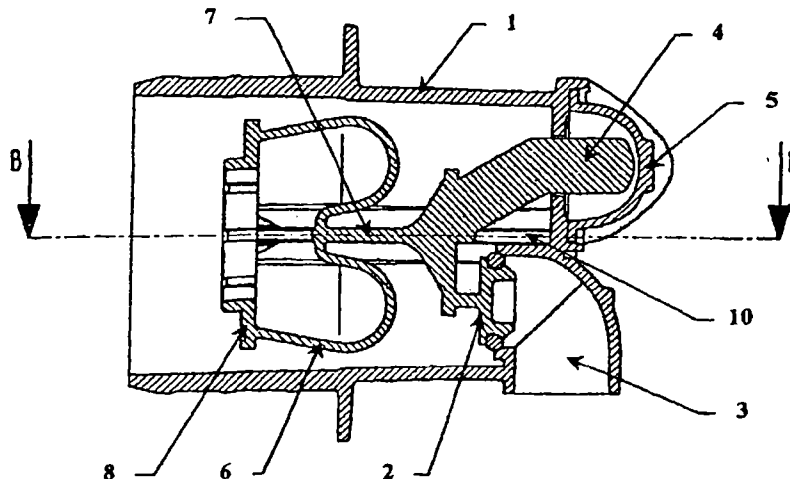

(57) Abstract: The invention concerns a liquid dispensing tap, essentially consisting of a body (1) for being mounted in the bung of a container and for dispensing liquid, a valve or a membrane (2) for sealing an orifice (3) dispensing the liquid, provided with a control member (4) and made in a single-piece with said control member (4) and with means (6) for sealed pressing of said valve (2) or membrane sealing the liquid dispensing orifice (3) on its seat, said valve being housed in the part of the body (1) opposite to the part designed to be mounted in the bung, and means for actuating said control member (4). Said tap is characterized in that the means (6) for sealed pressing of the valve (2) or membrane sealing the liquid dispensing orifice (3) on its seat consists of an elastically deformable element forming a spring and linked to the valve or membrane (2) sealing the liquid dispensing orifice (3) and to the control member (4) via a common guide element (7) and to a fixing flange (8) co-operating with pins (9) fixing and centering the body (1). The invention is more particularly applicable in the manufacture of taps for dispensing liquids contained in small rigid, semirigid or flexible containers, in particular food liquids.

[Suite sur la page suivante]

TAP FOR DISTRIBUTION OF LIQUIDS

The present invention relates to the field of the production of taps for the distribution of liquids contained in small rigid, semi-rigid or flexible containers, and particularly comestible liquids, and has for its object such a tap.

At present, the distribution of comestible beverages, particularly table wines, fruit juices or milk sterilized at ultrahigh temperature in small rigid, semi-rigid or flexible containers, such as containers of synthetic material, usually takes place by means of taps fixed in the outlet bung of these receptacles.

To this end, there are known taps constituted by bodies for mounting in the bung of a receptacle and by a piston for release of the liquid, loaded with a spring and guided in the body, the piston acting a resilient sealing membrane secured to the body. The mounting body in the bung is provided with a securement sleeve connecting snap fittingly with the bung.

Such taps permit correct distribution of the liquid and are perfectly suitable, either for a bottling operation or a series of withdrawals, whether these are latter are carried out in a sterile environment, such as a sterile chamber with a septic filling or not, for example for filling glasses or small receptacles, which is to say for individual use, or in restaurants for small servings of a single beverage or a single vintage.

There are also known taps for liquid distribution, particularly comestible liquids that are aseptic or not, with an automatic closure, which are constituted by a mounting body in the bung of a receptacle and by a piston

for releasing the liquid, acting on a resilient sealing membrane secured to the body, these taps being provided with means for holding the piston in an open position.

There also exist other taps of the type with a stopper, in which the passage of the liquid is effected by placing passage openings in registry by means of a lever or a manipulating handle.

All these known taps permit correctly performing their essential function of sealingly closing a receptacle with the possibility of withdrawal of the liquid content.

However, these known taps have the drawback of being of a relatively complicated construction, requiring the use of several pieces, such that their material cost, as well as the cost of assembly, is relatively high. Moreover, the actuation of the piston or the membrane for closing the distribution opening is always carried out by means of intermediate members for transmitting and transforming the movement.

Thus, there is also known from U.S. Patent 4,693,400, a tap for the distribution of liquids constituted by a mounting body in the bung of a receptacle and for distribution of the liquid, by a sealed closure valve from a distribution opening of the liquid, provided with a control member and made in the form of a single piece element with said control member and with a sealed application means for said closure valve sealing the distribution opening for the liquid on its seat, said valve being disposed in the body portion opposite that for mounting in the bung, and by actuating means for said control member.

Similarly, U.S. Patents 6,045,119 and 5,553,745 also disclose taps in several pieces.

The present invention has for its object to overcome the drawbacks of the known distribution taps and to provide such a tap having a simpler construction of less costly manufacture.

5 According to the invention, the liquid distribution tap, which is essentially constituted by a body for mounting in the bung of a receptacle and for distribution of the liquid, by a valve or a membrane for the sealed closure of a distribution opening for the liquid, provided
10 with a control member, is in the form of a single piece element with said control member and with a sealed application means for said valve or sealed closure member of the distribution outlet of the liquid on its seat, said valve or membrane being disposed in the portion of the body
15 opposite that in which is mounted the bung, and by an actuating means for said control member, is characterized in that the sealed application means for the valve or sealed closure membrane for the distribution opening of the liquid on its seat, is constituted by a resiliently
20 deformable member forming a spring and connected on the one hand to the valve or sealed closure membrane for the distribution opening of the liquid and to the control member by means of a common guide element and, on the other hand, with a securement flange coacting with securement and
25 centering lugs on the body.

The invention will be better understood from the following description, which relates to a preferred embodiment, given by way of non-limiting example, and explained with reference to the accompanying schematic
30 drawings, in which:

Figure 1 is a side elevational view in cross-section of the tap according to the invention, in the closed position;

5 Figure 2 is a view similar to that of Figure 1, showing the tap in the open and service position;

Figure 3 is a cross-sectional view on the line A-A of Figure 2, of the tap body alone;

Figure 4 is a cross-sectional view on the line B-B of Figure 1, and

10 Figure 5 is a perspective view of the single piece element.

Figures 1 to 4 of the accompanying drawings show a tap for the distribution of liquids, which is essentially constituted by a body 1 for mounting in the bung of a
15 receptacle (not shown) and for distribution of the liquid, by a valve or a membrane 2 for sealed closure of an opening 3 for dispensing of the liquid, provided with a control member 4 and made in the form of a single piece element with said control member 4 and with a sealed application
20 means 6 of said valve 2 or membrane for the sealed closure of the opening 3 for distribution of the liquid on its seat, said valve or membrane 2 being disposed in the portion of the body 1 opposite the portion for mounting in the bung, and by a means 5 for actuating said control
25 member 4.

According to the invention, and as shown more particularly, by way of example, in Figures 1 and 2 of the accompanying drawings, the means 6 for sealed application of the valve 2 or membrane for sealed closure of the
30 opening 3 for dispensing of the liquid on its seat is constituted by a resiliently deformable element forming a spring and connected on the one hand to the valve or

membrane 2 for sealed closure of the opening 3 for dispensing the liquid and to the control member 4 by means of a common guide element 7 and, on the other hand, to a securement flange 8 coacting with securement and centering lugs 9 of the body 1 (Figure 4).

The common guide element 7 is in the form of a slide and coacts with two guide rails 10 integral with the body 1 of the tap, which is preferably in the form of a single piece element, at the end opposite that for mounting said body in the bung (Figures 1, 2 and 4).

The actuating means 5 for the control member 4 is constituted, as shown in Figures 1, 2 and 4 of the accompanying drawings, by a pushbutton in the form of a resiliently deformable membrane provided on the body 1 of the tap and connected to the latter in a sealed manner.

The elastically deformable element 6 forming a spring and constituting the means 6 for sealed application of the valve 2 or membrane for sealed closure of the opening 3 for dispensing the liquid on its seat, is preferably constituted by a pair of resilient blades each connected to an end of the common guide element 7 on the side opposite the connection portion between the control member 4 and the valve or membrane 2 (Figures 1, 2 and 5), and at the other end to the securement flange 8 coacting with the securement and centering lugs 9 of the body 1 (Figure 4), said resilient blades forming a loop between their two ends. Such an embodiment of the means 6 permits, simply because of the construction in the form of blades in a loop, loading the movable elements formed by the control member 4 and the valve or membrane 2, under a predetermined tension in the direction of closing of the opening 3 by the valve or membrane.

The securement flange 8, connected to the resiliently deformable element 6 forming a spring and constituting the means 6 for sealed application of the valve 2 or membrane for sealed closure of the opening 3 for distribution of the liquid on its seat, is provided with piercings 9' of a shape corresponding to that of the securement and centering lugs 9 and is secured to these latter by riveting or by welding after mounting (Figures 4 and 5).

The operation of the tap according to the invention will be clearly seen from Figure 1, 2, 4 and 5.

Starting with a tap according to Figure 1, this tap being mounted in a bung of a receptacle, pressing on the pushbutton forming the actuating means 5 for the control member 4 has the effect of moving this latter together with the valve or membrane 2 against the action of the resiliently deformable means 6, by means of the slide forming the common guide element 7. Such a movement is carried out with guidance by co-action of the common guide element 7 with the guide rails 10 integrated into the body 1 (Figures 1, 2 and 4).

In the position shown in Figure 2 of the accompanying drawings, the opening 3 for dispensing the liquid is freed by raising of the valve or membrane 2 from its seat and the liquid contained within the receptacle to which the valve is connected, can flow through said opening 3 for distribution of liquid and can thus be transferred into a consumption receptacle or into an intermediate receptacle before consumption. A relaxation of the pressure on the pushbutton 5 has the immediate effect of returning the control member 4 to its position and also the valve or membrane 2, under the action of the element 6, and hence the closing of the opening 3.

Because of the provision of guide means formed by rails 10 and by the slide formed by the common guide element 7, the assembly of movable elements of the tap is perfectly maintained during its movement.

5 Thanks to the invention, it is possible to provide a tap for the distribution of liquids contained in small rigid, semi-rigid or flexible containers, in particular comestible liquids, permitting very reliable operation and easy manipulation. Moreover, this tap is of simple
10 construction and requires few pieces to be assembled, such that its production cost is relatively low. Finally, because of the simplicity of its design, this tap can be made in a compact form.

Of course, the invention is not limited to the
15 embodiment described and shown in the accompanying drawings. Modifications remain possible, particularly as to the construction of the various elements or by substitution of technical equivalents, without thereby departing from the scope of protection of the invention.

CLAIMS

1. Tap for the distribution of liquids, essentially constituted by a body for mounting in the bung of a receptacle and for distribution of the liquid, by a valve or membrane for sealed closure of an opening for distribution of the liquid, provided with a control member and made in the form of a single piece element with said control member and with a means for sealed application of said valve or member sealingly closing the opening for dispensing the liquid on its seat, said valve being disposed in the portion of the body opposite that for mounting in the bung, and by a means for actuating said control member, characterized in that the means for sealed application of the valve or member for sealed closure of the opening for distribution of the liquid on its seat, is constituted by a resiliently deformable element forming a spring and connected on the one hand to the valve or membrane for sealed closure of the opening for distribution of the liquid, and to the control member by means of a common guide element and, on the other hand, to a securement flange co-acting with securement lugs for the centering of the body.

2. Tap according to claim 1, characterized in that the common guide element is constituted by a slide and co-acts with two guide rails integrated in the body of the tap, which is in the form of a single piece element, at the end opposite that on which said body is mounted in the bung.

3. Tap according to claim 1, characterized in that the means for actuating the control member is constituted by a pushbutton in the form of a resiliently deformable membrane provided on the body of the valve and connected to the
5 latter in a sealed manner.

4. Tap according to claim 1, characterized in that the resiliently deformable element forming a spring and constituting the means for sealed application of the valve
10 or membrane for sealed closing of the opening for dispensing the liquid on its seat is constituted in the form of a pair of resilient blades each connected by one end to the common guide element on the side opposite the connection portion between the control member and the valve
15 or membrane, and at the other end of the securement member co-acting with securement and centering lugs on the body, said resilient blades forming a loop between their two ends.

20 5. Tap according to claim 1, characterized in that the securement flange, connected to the resiliently deformable member forming a spring and constituting the means for sealed application of the valve or closure membrane sealed with the opening for dispensing the liquid on its seat, and
25 provided with openings of a shape corresponding to that of the securement and centering lugs and is secured with these latter by riveting or welding after mounting.

6. A tap for the distribution of liquids substantially
30 as herein described with reference to and as illustrated in the accompanying drawings.