

(19) **DANMARK**

(10) **DK/EP 2562247 T3**



(12) **Oversættelse af  
europæisk patentskrift**

Patent- og  
Varemærkestyrelsen

- 
- (51) Int.Cl.: **C 12 M 1/38 (2006.01)** **C 12 N 15/11 (2006.01)** **C 12 Q 1/68 (2006.01)**
- (45) Oversættelsen bekendtgjort den: **2016-04-18**
- (80) Dato for Den Europæiske Patentmyndigheds bekendtgørelse om meddelelse af patentet: **2016-02-10**
- (86) Europæisk ansøgning nr.: **11772265.2**
- (86) Europæisk indleveringsdag: **2011-04-22**
- (87) Den europæiske ansøgnings publiceringsdag: **2013-02-27**
- (86) International ansøgning nr.: **KR2011002911**
- (87) Internationalt publikationsnr.: **WO2011132977**
- (30) Prioritet: **2010-04-23 KR 20100037960** **2011-04-21 KR 20110037352**
- (84) Designerede stater: **AL AT BE BG CH CY CZ DE DK EE ES FI FR GB GR HR HU IE IS IT LI LT LU LV MC MK MT NL NO PL PT RO RS SE SI SK SM TR**
- (73) Patenthaver: **Nanobiosys Inc., Rm.1004, Hanshin IT Tower 2-cha , 60-18 Gasan-dong , Geumcheon-gu, Seoul 153-712, Sydkorea**
- (72) Opfinder: **KIM, Sung Woo, Rm.104, Royal Villa, 228-2 Yeokchon-dong, Eunpyeong-gu, Seoul 122-904, Sydkorea**  
**KIM, Duck Joong, 103-1803, Seoksu Haneulchae Apt., Seoksu-dong, Manan-gu, Anyang-si, Gyeonggi-do 430-040, Sydkorea**  
**KIM, Sun Jin, Rm.202, 330-81 Hongje 1-dong, Seodaemun-gu, Seoul 120-859, Sydkorea**  
**RYU, Ho Sun, Rm.B101, 272-5 Yangpyeongdong 4-ga, Yeongdeungpo-gu, Seoul 150-867, Sydkorea**  
**LEE, Dong Hoon, Rm.201, 31-14 Bakdal-dong, Manan-gu, Anyang-si, Gyeonggi-do 430-030, Sydkorea**
- (74) Fuldmægtig i Danmark: **Zacco Denmark A/S, Arne Jacobsens Allé 15, 2300 København S, Danmark**
- (54) Benævnelse: **PCR-indretning med to varmeblokke**
- (56) Fremdragne publikationer:  
**EP-A1- 2 145 949**  
**WO-A1-97/40939**  
**WO-A1-97/48818**  
**WO-A2-2006/116616**  
**KR-A- 20060 116 983**  
**KR-A- 20060 116 984**  
**KR-A- 20100 008 476**  
**US-A- 5 819 842**  
**US-A1- 2006 046 304**  
**US-A1- 2008 176 290**  
**US-A1- 2009 053 801**  
**LEE D.-S. ET AL. : 'BULK-MICROMACHINED SUBMICROLITER-VOLUME PCR CHIP WITH VERY RAPID THERMAL RESPONSE AND LOW POWER CONSUMPTION' LAB CHIP vol. 4, 2004, pages 401 - 407,**

Fortsættes ...

XP009047295

## **DESCRIPTION**

### **TECHNICAL FIELD**

[0001] The present invention relates to a polymerase chain reaction (PCR) device including a heating block which is used for nucleic acid amplification.

### **BACKGROUND ART**

[0002] Polymerase chain reaction (PCR) is a technique of repeatedly heating and cooling a sample solution including nucleic acid to chain-replicate a region of the nucleic acid having a specific base sequence and thus to exponentially amplify the nucleic acid having the specific base sequence region and is commonly used in the fields, such as life science, genetic engineering, and medicine, for analysis and diagnosis.

[0003] Recently, various PCR devices have been developed to perform the PCR. A PCR device according to an example is installed with a container including a sample solution including nucleic acid in one reaction chamber and performs the PCR by repeatedly heating and cooling the container. Although an overall structure is not complicated since the PCR device of the example includes one reaction chamber, complicated circuits need to be included for accurate temperature control, and a total time for the whole PCR may be extended due to the repeated heating and cooling of one reaction chamber. Also, a PCR device according to another example is installed with a plurality of reaction chambers at a temperature for the PCR and performs the PCR by allowing a sample solution, including nucleic acid, to flow via one channel which passes through the reaction chambers. Although complicated circuits for accurate temperature control are not needed as the PCR device of another example uses a plurality of reaction chambers, a long flow channel that passes through the reaction chambers having high and low temperatures is necessary, and thus, an overall structure may be complicated, and a separate control device is required to control a flow rate of the sample solution, including nucleic acid, which flows via the channel that passes through the reaction chambers.

[0004] Therefore, a PCR device that may have a simple overall structure, minimize a total PCR reaction time, and obtain reliable PCR yield is desired.

[0005] Document US 2006/0046304 A1 relates to a thermal device, system and method for thermally treating a fluid processing device.

[0006] Document US 2008/0176290 A1 pertains to an apparatus for high throughput chemical reactions.

### **DETAILED DESCRIPTION OF THE INVENTION**

#### **TECHNICAL PROBLEM**

[0007] The present invention provides a polymerase chain reaction (PCR) device exhibiting excellent performance in a nucleic acid amplification reaction.

#### **TECHNICAL SOLUTION**

[0008] According to the present invention, there is provided a polymerase chain reaction (PCR) device according to claim 1.

[0009] Preferred embodiments are detailed in the dependent claims.

#### **ADVANTAGEOUS EFFECTS**

[0010] As PCR device including two heating blocks according to the present invention is provided, nucleic acid amplification reactions may be effectively performed.

## DESCRIPTION OF THE DRAWINGS

### [0011]

FIG. 1 illustrates a PCR device including two heating blocks according to an embodiment of the present invention.

FIG. 2 illustrates each step of nucleic acid amplification reaction due to movement of a chip holder of the PCR device according to an embodiment of the present invention.

FIG. 3 illustrates steps of detecting nucleic acid amplification reaction in real time using the PCR device according to an embodiment of the present invention.

FIG. 4 illustrates a chip for PCR installed in the chip holder of the PCR device according to an embodiment of the present invention.

FIG. 5 illustrates a cross-section of the chip for PCR installed in the chip holder of the PCR device according to an embodiment of the present invention which is treated with a double-sided adhesive, thermoplastic resin, or thermosetting resin.

## BEST MODE

[0012] Hereinafter, exemplary embodiments of the present invention will be described in greater detail with reference to the attached drawings.

[0013] FIG. 1 illustrates a PCR device 1 including two heating blocks according to an embodiment of the present invention.

[0014] The PCR device 1 according to an embodiment of the present invention includes a first heating block 100 disposed on a substrate 400; a second heating block 200 disposed separate from the first heating block 100 on the substrate 400; and a chip holder 300 that is capable of being moved left-right and/or up-down by a driving means 500 over the first and second heating blocks 100 and 200, and is installed with a chip for PCR 900.

[0015] The PCR device 1 is a device that is used in the PCR (Polymerase Chain Reaction) to amplify nucleic acid having a specific base sequence. For example, a PCR device for amplification of DNA (deoxyribonucleic acid) having a specific base sequence performs three steps: denaturing, annealing, and extension, and the DNA having the specific base sequence may be exponentially amplified by repeating, for example, 20 to 40 cycles of the three steps: the denaturing step involves heating a sample solution including double-stranded DNA to a predetermined temperature, for example about 95 °C, to separate the double-stranded DNA into single-stranded DNA; the annealing step involves providing oligonucleotide primers having a sequence complementary to the specific base sequence to be amplified to the sample solution, cooling the separated single-stranded DNA along with the primers to a predetermined temperature, for example 55 °C, and thus binding the primers to a specific base sequence of the single-stranded DNA, thereby forming a partially DNA-primer complex; and the extension (or amplification) step involves maintaining a temperature of the sample solution after the annealing step at an appropriate temperature, for example 72 °C, and thus forming double-stranded DNA by the action of DNA polymerase based on primers of the partially DNA-primer complex. Also, in some embodiments, the PCR device may perform the annealing step and the extension (or amplification) step at the same time, and in this regard, the PCR may complete one cycle by performing a two-step process consisting of the annealing step and the annealing and extension (or amplification) step. Therefore, the PCR device 1 according to an embodiment of the present invention refers to a device including modules for performing the steps stated above, and the modules not stated herein in detail are assumed as if they are all included within the obvious scope disclosed in the prior art for performing PCR.

[0016] The PCR device 1 according to an embodiment of the present invention includes the first heating block 100 disposed on the substrate 400 and the second heating block 200 disposed separate from the first heating block 100 on the substrate 400.

[0017] The substrate 400 includes any material having physical and/or chemical properties that do not change due to heating or maintaining the temperature of the first heating block 100 and the second heating block 200 and via which heat exchange

between the first heating block 100 and the second heating block 200 does not occur. For example, the substrate 400 may include a material such as plastic or may be formed of such material.

**[0018]** The first heating block 100 and the second heating block 200 are disposed to maintain a temperature for performing the denaturing, annealing, and extension (or amplification) steps to amplify nucleic acid. Thus, the first heating block 100 and the second heating block 200 may provide a necessary temperature required in each of the steps and may include various modules for maintaining the temperature or may be drivably connected to the modules. Thus, when the chip holder 300 installed with the chip for PCR 900 contacts a surface of one of the first and second heating blocks 100 and 200, a sample solution in the chip for PCR 900 may be evenly heated and maintained at a desired temperature since the entire surface of the first heating block 100 or the second heating block 200 in contact with the chip for PCR 900 may be heated or maintained at a desired temperature. Unlike a conventional PCR device using a single heating block has a rate of temperature change of the single heating block in a range of 3 to 7 °C per second, the PCR device 1 including the two heating blocks according to an embodiment of the present invention may significantly reduce a PCR time as a rate of temperature change of each of the first and second heating blocks 100 and 200 may be in a range of 20 to 40 °C per second.

**[0019]** A heating wire (not shown) may be disposed in each of the first and second heating blocks 100 and 200. The heating wire may be drivably connected to various heat sources to maintain a temperature for performing the denaturing, annealing, and extension (or amplification) steps or may be drivably connected to various temperature sensors to monitor a temperature of the heating wire. The heating wire may be disposed symmetrically in up-down and/or left-right directions based on a center of each surface of the first and second heating blocks 100 and 200 to evenly maintain an overall temperature inside the first and second heating blocks 100 and 200. An arrangement of the heating wire symmetrical in up-down and/or left-right directions may vary. Also, thin film heaters (not shown) may be disposed inside the first or second heating block 100 or 200. The thin film heaters may be separately disposed with a regular distance in up-down and/or left-right directions based on a center of each surface of the first and second heating blocks 100 and 200 to evenly maintain an overall temperature inside the first and second heating blocks 100 and 200. A regular arrangement of the thin film heaters in up-down and/or left-right directions may vary.

**[0020]** The first and second heating blocks 100 and 200 may include a metal material, for example, may include an aluminum material or may be formed of an aluminum material, for even heat distribution and rapid heat transfer to the same area.

**[0021]** The first heating block 100 may be manufactured to maintain an appropriate temperature for performing the denaturing step, or the annealing and extension (or amplification) step. For example, the first heating block 100 of the PCR device 1 according to an embodiment of the present invention may maintain a temperature from 50 to 100 °C, may maintain a temperature from 90 to 100 °C, preferably 95 °C, when the denaturing step is performed at the first heating block 100, or may maintain a temperature from 55 to about 75 °C, preferably 72 °C, when the annealing and extension (or amplification) step is performed at the first heating block. However, the temperature is not limited thereto as long as the denaturing step, or the annealing and extension (or amplification) step may be performed. The second heating block 200 may be manufactured to maintain an appropriate temperature for performing the denaturing step or the annealing and extension (or amplification) step. For example, the second heating block 200 of the PCR device 1 according to an embodiment of the present invention may maintain a temperature from 90 to 100 °C, preferably 95 °C, when the denaturing step is performed at the second heating block 200, or may maintain a temperature from 55 to 75 °C, preferably 72 °C, when the annealing and extension (or amplification) step is performed at the second heating block 200. However, the temperature is not limited thereto as long as the denaturing step or the annealing and extension (or amplification) step may be performed. Therefore, according to an embodiment of the present invention, the first heating block 100 may maintain a denaturing temperature of PCR. When a denaturing temperature is lower than 90 °C, the nucleic acid that forms a template for the PCR is denatured, yielding a decrease in efficiency of the PCR, thus a PCR efficiency may be decreased or the PCR may not occur. Also, when a denaturing temperature is higher than 100 °C, an enzyme used in the PCR may lose its activity, thus the denaturing temperature may be from 90 to 100 °C, preferably 95 °C. Also, according to an embodiment of the present invention, the second heating block 200 may maintain an annealing and extension (or amplification) temperature of PCR. When the annealing and extension (or amplification) temperature is lower than 55 °C, specificity of the PCR product may be decreased, and when the annealing and extension (or amplification) temperature is higher than 74 °C, a PCR efficiency may be decreased as an extension due to the primers may not occur, thus the annealing and extension (or amplification) temperature may be from 55 to 75 °C, preferably 72 °C.

**[0022]** The first and second heating blocks 100 and 200 may be separately disposed at a predetermined distance so that heat exchange therebetween may not occur. Accordingly, since heat exchange between the first heating block 100 and second heating block 200 does not occur, accurate temperature control at the denaturing step and the annealing and extension (or amplification) step may be enabled in a nucleic acid amplification reaction which may be significantly affected by a slight temperature change.

**[0023]** The PCR device 1 according to an embodiment of the present invention includes a chip holder 300 that is capable of

being moved left-right and/or up-down by a driving means 500 over the first and second heating blocks 100 and 200, and is installed with a chip for PCR 900. Also, the chip for PCR 900 may be manufactured to contact a surface of the first heating block 100 or the second heating block 200 and to contain a sample solution including nucleic acid to be amplified.

**[0024]** The chip for PCR 900 may contain a sample solution including nucleic acid, such as double-stranded DNA, oligonucleotide primers having a sequence complementary to a specific base sequence to be amplified, DNA polymerase, deoxyribonucleotide triphosphates (dNTP), or a PCR reaction buffer. The chip for PCR 900 may include an inlet unit (not shown) for introducing the sample solution, an outlet unit (not shown) for withdrawing the sample solution that completed the nucleic acid amplification reaction, and a reaction chamber (or channel) (not shown) where the nucleic acid amplification reaction of the sample solution is performed. When the chip for PCR 900 is in contact with the first and second heating block 100 and 200, heat of the first and second heating block 100 and 200 is transferred to the chip for PCR 900, and thus the sample solution included in the reaction chamber (or channel) of the chip for PCR 900 may be heated and maintained at a temperature. Also, the chip for PCR 900 may have an overall planar shape, but is not limited thereto. Moreover, when the nucleic acid amplification reaction is performed by the PCR device 1, an outer wall of the PCR chip 900 may have a shape and structure for the chip for PCR 900 to be fixed in an inner space of the chip holder 300 so that the chip for PCR 900 does not dissociate from the chip holder 300. A detailed description of the chip for PCR 900 will be described hereinafter with reference to FIGS. 4 and 5.

**[0025]** The chip holder 300 is a module for the chip for PCR 900 to be installed in the PCR device 1. When the nucleic acid amplification reaction is performed by the PCR device 1, an inner wall of the chip holder 300 may have a shape and structure for the chip for PCR 900 to be fixed on the outer wall of the chip for PCR 900 so that the chip for PCR 900 does not dissociate from the chip holder 300. The chip holder 300 may be drivably connected to the driving means 500. Also, the chip for PCR 900 may be detachable from the chip holder 300.

**[0026]** The driving means 500 includes all means enabling the chip holder 300 installed with the chip for PCR 900 to move left-right and/or up-down over the first and second heating blocks 100 and 200. As the driving means 500 moves left-right, the chip holder 300 installed with the chip for PCR 900 may move back and forth between the first heating block 100 and second heating block 200, and as the driving means 500 moves up-down, the chip holder 300 installed with the chip for PCR 900 may be in contact with and be separated from the first and second heating block 100 and 200. As shown in FIG. 1, the driving means 500 of the PCR device 1 according to an embodiment of the present invention includes a rail 510 that extends in the left-right direction and a connection member 520 that is disposed as to enable a sliding motion in the left-right direction via the rail 510 and enable a sliding motion in the up-down direction, wherein the chip holder 300 is disposed at an end of the connection member 520. The left-right and/or up-down movement of the driving means 500 may be controlled by a controlling means (not shown) drivably disposed inside or outside of the PCR device 1, and the controlling means may control the contact and separation between the chip holder 300 installed with the chip for PCR 900 for denaturing step and annealing and extension (or amplification) step of PCR and the first or second heating block 100 or 200.

**[0027]** FIG. 2 illustrates each step of the nucleic acid amplification reaction due to the movement of the chip holder of the PCR device according to an embodiment of the present invention.

**[0028]** The nucleic acid amplification reaction due to the PCR device 1 according to an embodiment of the present invention has the following steps: First, a sample solution including nucleic acid, such as double-stranded DNA, oligonucleotide primers having a sequence complementary to a specific base sequence to be amplified, DNA polymerase, dNTP, or a PCR reaction buffer, is introduced to the chip for PCR 900, the chip for PCR 900 may be installed in the chip holder 300. Next or at the same time, the first heating block 100 may be heated up to a temperature for the denaturing step, for example 90 to 100 °C, and maintained at the temperature, preferably heated up to 95 °C and maintained at the temperature. The second heating block 200 may be heated up to a temperature for the annealing and extension (or amplification) step, for example 55 to 75 °C, and maintained at the temperature, preferably heated up to 72 °C and maintained at the temperature.

**[0029]** Then, the connection member 520 of the driving means 500 may be controlled to move the chip for PCR 900 downward, thus the chip holder 300 installed with the chip for PCR 900 may be in contact with the first heating block 100 to perform a first denaturing step (step x) of PCR.

**[0030]** Subsequently, the connection member 520 of the driving means 500 may be controlled to move the chip for PCR 900 upward, thus the chip holder 300 installed with the chip for PCR 900 may be separated from the first heating block 100 to terminate the first denaturing step of PCR, the connection member 520 of the driving means 500 may be controlled to perform a step to move the chip for PCR 900 above the second heating block 200 (step y).

**[0031]** Next, the connection member 520 of the driving means 500 may be controlled to move the chip for PCR 900 downward, thus the chip holder 300 installed with the chip for PCR 900 may be in contact with the second heating block 100 to perform the first annealing and extension (or amplification) step of PCR (step z).

**[0032]** Lastly, the connection member 520 of the driving means 500 may be controlled to move the chip for PCR 900 upward, thus the chip holder 300 installed with the chip for PCR 900 may be separated from the second heating block 100 to terminate the first annealing and extension (or amplification) step of PCR, the connection member 520 of the driving means 500 may be controlled to move the chip for PCR 900 above the first heating block 100 and repeat the steps x, y, and z, thereby performing the nucleic acid amplification reaction (circulating step).

**[0033]** FIG. 3 illustrates steps of monitoring the nucleic acid amplification reaction in real-time using the PCR device according to an embodiment of the present invention.

**[0034]** In the PCR 1 device according to an embodiment of the present invention, a light source 700 is further interposed between the first and second heating blocks 100 and 200, and a light detection unit 800 for detecting the light emitted from the light source 700 is further disposed on the chip holder 300; or the light detection unit 800 for detecting the light emitted from the light source 700 is further interposed between the first and second heating blocks 100 and 200, and the light source 700 is further disposed on the chip holder 300. Also, the light detection unit 800 may be disposed on the driving means 500, and a transmission unit 530 for transmitting the light emitted from the light source 700 may be disposed in the driving means 500. Also, the chip for PCR 900 may be a light transmitting material, particularly a light transmitting plastic material. The detailed description of the chip for PCR 900 will be described hereinafter with reference to FIGS. 4 and 5.

**[0035]** During the nucleic acid amplification reaction due to the PCR device 1 according to an embodiment of the present invention, a degree of the nucleic acid being amplified in the chip for PCR 900 may be detected in real time by disposing the light source 700 and the light detection unit 800. For detecting the degree of the nucleic acid being amplified in the chip for PCR, a separate fluorescent material may be further added to the sample solution that is introduced to the chip for PCR 900. The light source 700 is disposed to distribute over the separate space between the first and second heating blocks 100 and 200 as wide as possible and is disposed to emit possibly the same light. The light source 700 may be connected and disposed to be drivable with a lens (not shown) collecting the light emitted from the light source 700 and a light filter (not shown) filtering light at a range of particular wavelengths.

**[0036]** During the nucleic acid amplification reaction due to the PCR device 1 according to an embodiment of the present invention, steps of detecting the degree of the nucleic acid being amplified in the chip for PCR 900 in real time are as follows. When the connection member 520 of the driving means 500 is controlled to move the chip for PCR 900 from above the first heating block 100 to above the second heating block 200 after completing the first denaturing step of the PCR, or when the connection member 520 of the driving means 500 is controlled to move the chip for PCR 900 from above the second heating block 200 to above the first heating block 100 after completing the first annealing and extension (or amplification) step of the PCR, the connection member 520 of the driving means 500 is controlled to stop the chip holder 300 installed with the chip for PCR 900 in the separate space between the first and second heating blocks 100 and 200. Then, light is emitted from the light source 700, the emitted light transmits through the chip for PCR 900 which is light transparent, particularly the reaction chamber (or channel) of the chip for PCR 900, and in this case, a light signal generated by amplification of the nucleic acid inside the reaction chamber (or channel) is detected by the detection unit 800. In this case, the light transmitted through the chip for PCR 900 which is light transparent may arrive at the detection unit 800 by transmitting through the driving means 500, particularly the transmission unit 530 disposed in the rail 510.

**[0037]** Thus, in regard of the PCR device 1 according to an embodiment of the present invention, an amount of target nucleic acid included in an initial reaction sample may be measured and analyzed in real time by monitoring the reaction results due to amplification of the nucleic acid (to which the fluorescent material is attached) in the reaction chamber (or channel) in real time while each of the circulation steps of the PCR proceeds.

**[0038]** FIG. 4 illustrates the chip for PCR 900 that is installed in the chip holder 300 of the PCR device 1 according to an embodiment of the present invention.

**[0039]** The chip for PCR 900 may contain a sample solution including nucleic acid, such as double-stranded DNA, oligonucleotide primers having a sequence complementary to a specific base sequence to be amplified, DNA polymerase, dNTP, or a PCR reaction buffer. The chip for PCR 900 may include an inlet unit 931 for introducing the sample solution, an outlet unit 932 for withdrawing the sample solution that completed the nucleic acid amplification reaction, and one or more reaction chambers (or channels) 921 in where the sample solution including nucleic acid to be amplified is contained. When the chip for

PCR 900 is in contact with the first heating block 100 or second heating block 200, heat of the first heating block 100 or the second heating block 200 is transferred to the chip for PCR 900, and thus the sample solution included in the reaction chamber (or channel) of the chip for PCR 900 may be heated or cooled and maintained at a constant temperature. Also, the chip for PCR 900 may have an overall planar shape, but is not limited thereto. Moreover, the chip for PCR 900 installed in the chip holder 300 may be disposed in contact with the first or second heating block 100 or 200. Thus, according to an embodiment of the present invention, a fact that the chip for PCR 900 is disposed on one surface of the first or second heating block 100 or 200 may indicate that the chip for PCR 900 installed in the chip holder 300 is disposed in contact with the first or second heating block 100 or 200. Also, the chip for PCR 900 may be formed of a light transmitting material, preferably a light transmitting plastic material. When plastic is used to manufacture the chip for PCR 900, an efficiency of heat transfer may be increased only by controlling a thickness of the plastic, and a cost of manufacture may be decreased as the manufacturing process is simple. Also, since the chip for PCR 900 may include light transmitting properties as a whole, light may be directly irradiated while the chip for PCR 900 is disposed on one surface of the first or second heating block 100 or 200, thus amplification of nucleic acid and a degree of the amplification may be measured and analyzed in real time.

**[0040]** A first plate 910 is disposed on a second plate 920. As the first plate 910 is disposed in contact with a lower surface of the second plate 920, a through opening channel 921 may form a type of PCR chamber. Also, the first plate 910 may be formed of various materials, preferably a material selected from the group consisting of polydimethylsiloxane (PDMS), cyclic olefin copolymer (COC), polymethyl methacrylate (PMMA), polycarbonate (PC), polypropylene carbonate (PPC), polyether sulfone (PES), polyethylene terephthalate (PET), and a combination thereof. In addition, a top surface of the first plate 910 is treated with a hydrophilic material 922 so that the PCR may be smoothly performed. A single layer including the hydrophilic material 922 may be formed on the first plate 910 due to the treatment the hydrophilic material 922. The hydrophilic material may be various materials, preferably a material selected from the group consisting of a carboxyl group (-COOH), amine group (-NH<sub>2</sub>), hydroxyl group (-OH), and sulfone group (-SH), and the treatment the hydrophilic material 922 may be performed using a known method in the art.

**[0041]** The second plate 920 is disposed on the first plate 910. The second plate 920 includes the through opening channel 921. The through opening channels 921 may be connected to a part corresponding to a through opening inlet unit 931 and a through opening outlet unit 932 and form a type of PCR chamber. Thus, PCR is performed after the sample solution to be amplified is introduced in the through opening channel 921. Also, two or more through opening channels 921 may be used depending on a purpose of use and scope of the PCR device 1 according to an embodiment of the present invention. Referring to FIG. 4, 6 through opening channels 921 are illustrated. Moreover, the second plate 920 may be formed of various materials, preferably a thermoplastic resin or thermosetting resin material selected from the group consisting of polymethyl methacrylate (PMMA), polycarbonate (PC), cyclic olefin copolymer (COC), polyamide (PA), polyethylene (PE), polypropylene (PP), polyphenylene ether (PPE), polystyrene (PS), polyoxymethylene (POM), polyetheretherketone (PEEK), polytetrafluoroethylene (PTFE), polyvinylchloride (PVC), polyvinylidene fluoride (PVDF), polybutylene terephthalate (PBT), fluorinated ethylene propylene (FEP), perfluoro alkoxyalkane (PFA), and a combination thereof. Also, a thickness of the second plate 920 may vary, and may be selected from 100  $\mu$ m to 200  $\mu$ m. Moreover, a width and length of the through opening channel 921 may vary, preferably a width of the through opening channel 921 may be selected from 0.5 mm to 3 mm, and a length of the through opening channel 921 may be selected from 20 mm to 40 mm. In addition, an inner wall of the second plate 920 may be coated with a material such as silane-based material or bovine serum albumin (BSA), and the coating may be performed using a known method in the art.

**[0042]** The third plate 930 is disposed on the second plate 920. The third plate 930 includes a through opening inlet unit 931, which is formed with respect to a portion of the through opening channel 921 formed in the second plate 920, and a the through opening outlet unit 932, which is formed with respect to the other portion of the through opening channel 921. The through opening inlet unit 931 is a region where the sample solution including the nucleic acid to be amplified is introduced. The through opening outlet unit 932 is a region where the sample solution is withdrawn after completing the PCR. Thus, the third plate 930 covers the through opening channel 921 formed in the second plate 920 which will be described herein, and the through opening inlet unit 931 and the through opening outlet unit 932 serve as an inlet unit and an outlet unit of the through opening channels 921. Also, the third plate 930 may be formed of various materials, preferably a material selected from the group consisting of polydimethylsiloxane (PDMS), cyclic olefin copolymer (COC), polymethyl methacrylate (PMMA), polycarbonate (PC), polypropylene carbonate (PPC), polyether sulfone (PES), polyethylene terephthalate (PET), and a combination thereof. Although a size of the through opening inlet unit 931 may vary, preferably a diameter of the through opening inlet unit 931 may be selected from 1.0 mm to 3.0 mm. Also, although a size of the through opening outlet unit 932 may vary, preferably a diameter of the through opening outlet unit 932 may be selected from 1.0 mm to 1.5 mm. Moreover, the through opening inlet unit 931 and the through opening outlet unit 932 include separate cover means (not shown), and thus leakage of the sample solution while the PCR is being performed for the sample solution in the through opening channel 921 may be prevented. The cover means may be formed in various shapes, sizes, or materials. Also, a thickness of the third plate may vary, preferably may be selected from 0.1 mm to 2.0 mm. Moreover, two or more through opening inlet units 931 and through opening outlet units 932 may be used.

[0043] FIG. 5 illustrates a cross-section of the chip for PCR 900 installed in the chip holder 300 of the PCR device according to an embodiment of the present invention which is treated with a double-sided adhesive, thermoplastic resin, or thermosetting resin.

[0044] The chip for PCR 900 may be easily manufactured by a method including providing the third plate 930 by forming the through opening inlet unit 931 and the through opening outlet unit 932 through a mechanical process; providing the second plate 920 by forming the through opening channels 921 in a board having a size corresponding to the lower surface of the third plate 930 from the region corresponding to the through opening inlet unit 931 of the third plate 930 to the region corresponding to the through opening outlet unit 932 of the third plate 930 via a mechanical process; providing the first plate 910 by forming a surface treated with the hydrophilic material 922 through a surface treatment process on an upper surface of a board having a size corresponding to the lower surface of the second plate 920; and bonding the lower surface of the third plate 930 to the upper surface of the second plate 920 through a bonding process, and the lower surface of the second plate 920 to the upper surface of the first plate 910 through a bonding process.

[0045] The through opening inlet unit 931 and the through opening outlet unit 932 of the third plate 930, and the through opening channel 921 of the second plate 920 may be formed by using a manufacturing method selected from the group consisting of injection molding, hot-embossing, casting, and laser ablation. Also, the hydrophilic material 922 on the surface of the first plate 910 may be treated by a method selected from the group consisting of an oxygen-argon plasma treatment, corona discharge treatment, and surfactant coating, or a known method in the art. Moreover, the lower surface of the third plate 930 and the upper surface of the second plate 920, and the lower surface of the second plate 920 and the upper surface of the first plate 910 may be bonded by using a thermal bonding, ultrasonic welding, or solvent bonding process, or by following a known method in the art. A double-sided tape, thermoplastic resin, or thermosetting resin 500 may be treated between the third plate 930 and the second plate 920, and between the second plate 920 and the third plate 910.

#### **Example**

[0046] A PCR device of another company which is commonly used and the PCR device according to an embodiment of the present invention shown in FIG. 3 were used to compare and analyze the results of performing a nucleic acid amplification reaction using each of the devices. The PCR device of another company was LightCycler 1.5 available from ROCHE Co., which is constructed of one heating block.

[0047] For reliability of the results of the nucleic acid amplification reaction, a sample solution of a positive control and a sample solution of a negative control were each prepared. For the positive control, the sample solution of about 60  $\mu\text{l}$  including 30  $\mu\text{l}$  of 2X SYBR green buffer, 4.4  $\mu\text{l}$  (50 ng/20  $\mu\text{l}$ ) of double-stranded template cDNA, pairs of primers complementarily binding to a specific base sequence, particularly 6  $\mu\text{l}$  (1 pmole) of forward primers, 6  $\mu\text{l}$  (1 pmole) of reverse primers, and 13.6  $\mu\text{l}$  of distilled water was prepared, and for the negative control, the sample solution of about 60  $\mu\text{l}$  including 30  $\mu\text{l}$  of 2X SYBR green buffer and 30  $\mu\text{l}$  of distilled water was prepared. Regarding a standard and size of the PCR device according to an embodiment of the present invention different from the PCR device of another company, about 30  $\mu\text{l}$  of the sample solutions were introduced to a chip of PCR is installed in the PCR device of another company, and about 5  $\mu\text{l}$  of the sample solutions were introduced to a chip of PCR is installed in the PCR device according to an embodiment of the present invention.

[0048] Under the experimental conditions state above, 20 cycles of PCR were first performed using the PCR device according to an embodiment of the present invention. A temperature of the first heating block was heated up and maintained at 95 °C, allowed to vary in a range of 90 to 100 °C, and a temperature of the second heating block was heated up and maintained at 72 °C, allowed to vary in a range of 55 to 75 °C. The sample solutions of the positive control and negative control were introduced to the chip for PCR, and the chip for PCR was installed in the chip holder of the PCR device. Then, the PCR device was operated. The denaturing step was performed for about 10 seconds, subsequently the annealing and extension (or amplification) step was performed for about 10 seconds, and a fluorescent detection value due to the nucleic acid amplification was measured after every cycle of each step. As a result, the fluorescent detection values showed an increase maintained curve after 5 minutes from the starting point of the PCR device operation. Also, under the experimental conditions, 20 cycles of PCR using the PCR device of another company were performed. As a result, 30 or more minutes were required to reach the fluorescent detection values achieved by the PCR device according to an embodiment of the present invention.

## **REFERENCES CITED IN THE DESCRIPTION**

This list of references cited by the applicant is for the reader's convenience only. It does not form part of the European patent document. Even though great care has been taken in compiling the references, errors or omissions cannot be excluded and the EPO disclaims all liability in this regard.

## Patent documents cited in the description

- [US20060046304A1 \[0005\]](#)
- [US20080176290A1 \[0006\]](#)

## Patentkrav

1. Polymerasekædereaktion (PCR)-indretning (1) omfattende:  
en første varmeblok (100), der er anbragt på et substrat (400);  
5 en anden varmeblok (200), der er anbragt adskilt fra den første varmeblok på substratet (400);  
en chipholder (300), der kan bevæges venstre-højre og/eller op-ned ved hjælp af et drivmiddel (500) over den første og anden varmeblok og er installeret med en chip (900) til PCR, hvor chippen til PCR kan aftages fra chipholderen (300),  
10 hvor chippen (900) til PCR er fremstillet til at komme i kontakt med en overflade af den første varmeblok (100) eller den anden varmeblok (200) og til at indeholde en prøveopløsning, der indeholder nukleinsyre, der som amplificeres,  
15 **kendetegnet ved, at** en lyskilde (700) endvidere er indført mellem den første og anden varmeblok, og en lysdetekteringsenhed (800) til detektering af lyset, der udsendes fra lyskilden (700), endvidere er anbragt over chipholderen (300); eller lysdetekteringsenheden (800) til detektering af lyset, der udsendes fra lyskilden (700), endvidere er indført mellem den første og anden varmeblok, og lyskilden (700) endvidere er anbragt over chipholderen (300).  
20
2. PCR-indretning (1) ifølge krav 1, hvor en varmetråd er anbragt i hver af den første og anden varmeblok.
- 25
3. PCR-indretning (1) ifølge krav 2, hvor varmetråden er anbragt symmetrisk i op-ned- og/eller venstre-højre-retninger i forhold til et centrum af hver overflade af den første og anden varmeblok for jævnt at opretholde en samlet temperatur inden i den første eller anden varmeblok.
- 30
4. PCR-indretning (1) ifølge krav 1, hvor den første og anden varmeblok (100, 200) er fremstillet til at opretholde en denatureringstemperatur af PCRen.
- 35
5. PCR-indretning (1) ifølge krav 4, hvor denatureringstemperaturen er fra ca. 90 til ca. 100 °C.

6. PCR-indretning (1) ifølge krav 1, hvor den første og anden varmeblok (100, 200) er fremstillet til at opretholde en udglødnings- og forlængelses- (eller forstærknings-)temperatur af PCR'en.
- 5 7. PCR-indretning (1) ifølge krav 6, hvor udglødnings- og forlængelses- (eller forstærknings-)temperaturen er fra ca. 55 til ca. 75 °C.
8. PCR-indretning (1) ifølge krav 1, hvor den første og anden varmeblok (100, 200) er anbragt adskilt i en forudbestemt afstand, således at der ikke sker nogen varmeudveksling derimellem.
- 10 9. PCR-indretning (1) ifølge krav 1, hvor drivmidlet (500) omfatter; en skinne (510), der strækker sig i venstre-højre-retningen; og et forbindelseselement (520), der er anbragt for at muliggøre en glidende bevægelse i venstre-højre-retningen via skinnen (510) og muliggør en glidende bevægelse i op-ned-retningen, hvor chipholderen (300) er anbragt i en ende af forbindelseselementet (520).
- 15 10. PCR-indretning (1) ifølge krav 1, hvor chippen (900) til PCR er et lysoverførende plastmateriale.
- 20 11. PCR-indretning (1) ifølge krav 1, hvor PCR-chippen (900) omfatter: en første plade (910); en anden plade (920), der er anbragt på den første plade (910) og omfatter gennemgangsåbningskanaler (921); og en tredje plade (930), der er anbragt på den anden plade (920) og omfatter en gennemgangsåbningsindgangsenhed (931), der er udformet i forhold til en del af den udformede gennemgangsåbningskanal, og en gennemgangsåbningsudgangsenhed (932), der er udformet i forhold til den anden del af gennemgangsåbningskanalen.
- 25 30 12. PCR-indretning (1) ifølge krav 11, hvor den første plade (910) og tredje plade (930) omfatter et materiale, der er valgt fra gruppen bestående af polydimethylsiloxan (PDMS), cyklisk olefinpolymer (COC), polymethylmethacrylat (PMMA), polycarbonat (PC), polypropylencarbonat (PPC), poly-
- 35

ethersulfon (PES), polyethylenterephthalat (PET) og en kombination deraf, og den anden plade omfatter et termoplastisk resin eller termohærdende resinmateriale, der er valgt fra gruppen bestående af polymethylmethacrylat (PMMA), polycarbonat (PC), cyklisk olefincopolymer (COC), polyamid (PA),  
5 polyethylen (PE), polypropylen (PP), polyphenylenether (PPE), polystyren (PS), polyoxymethylen (POM), polyetheretherketon (PEEK), polytetrafluorethylen (PTFE), polyvinylchlorid (PVC), polyvinylidenfluorid (PVDF), polybutylenterephthalat (PBT), fluorineret ethylenpropylen (FEP), perfluoralkoxyalkan (PFA) og en kombination deraf.

10

**13.** PCR-indretning (1) ifølge krav 11, en diameter af gennemgangsåbningsindgangsenheden (931) af den tredje plade (930) er valgt fra ca. 1,0 mm til ca. 3,0 mm, en diameter af gennemgangsåbningsudgangsenhederne (932) er valgt fra ca. 1,0 mm til ca. 1,5 mm, en tykkelse af den tredje plade (930) er valgt fra ca. 0,1 mm til ca. 2 mm, en tykkelse af den anden pladen (920) er  
15 valgt fra ca. 100 µm til ca. 200 µm, en bredde af gennemgangsåbningskanalerne (921) er valgt fra ca. 0,5 mm til ca. 3 mm, og en længde af gennemgangsåbningskanalen (921) er valgt fra ca. 20 mm til ca. 40 mm.

20

**14.** PCR-indretning (1) ifølge krav 10, hvor en overføringsenhed (530) til at overføre lyset, der udsendes fra lyskilden (700), er anbragt i drivmidlet (500).

DRAWINGS

FIG. 1

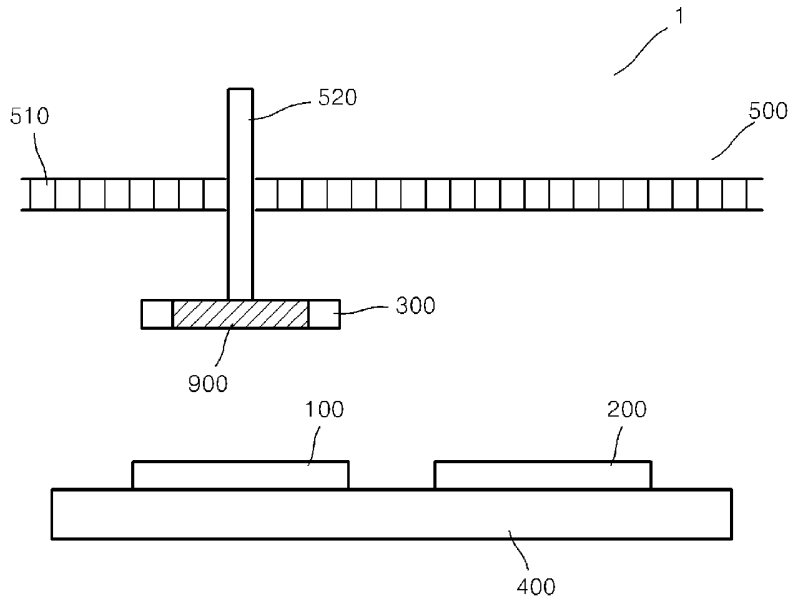

FIG. 2

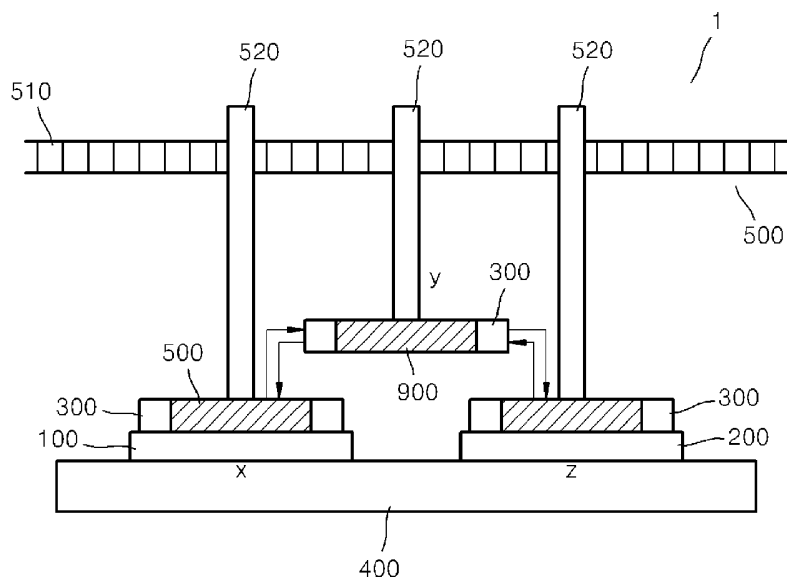

FIG. 3

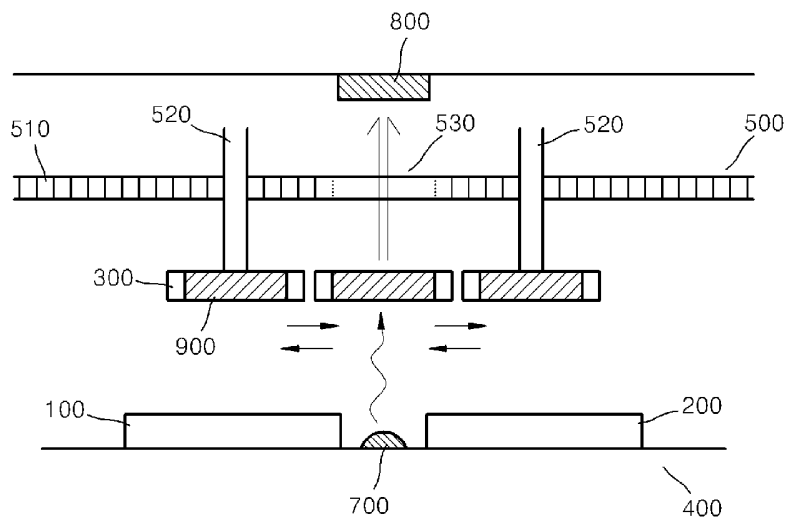

FIG. 4

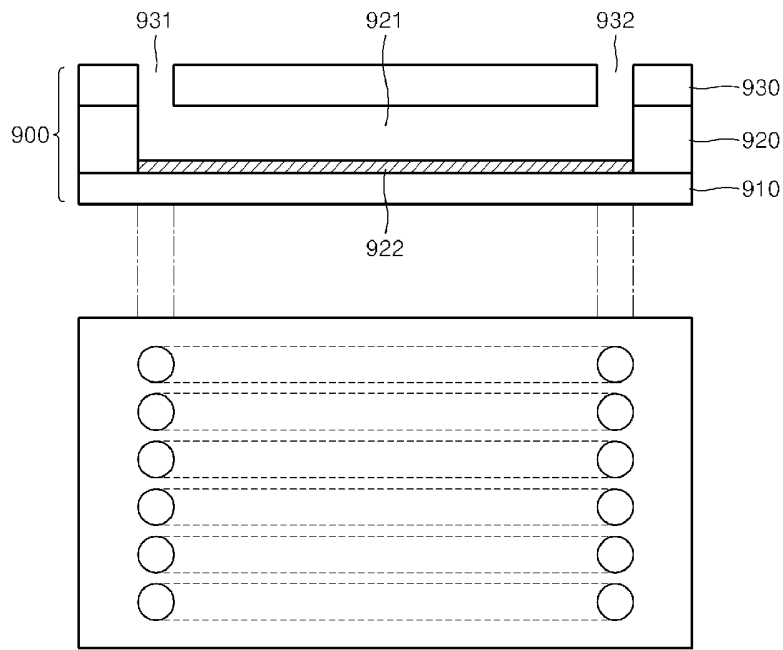

FIG. 5

